



SPECIFICATION

Surface Acoustic Wave Filter

USER



USER PART No.

WISOL PART No. **SFX707BYJ02**

DOC. No. SMS-51-L-SFT-FS-208

DATE December 10, 2018

REVISION 000

WISOL					
ISSUED BY	Park, Doo-Chul 	APPROVED BY (R&D)	Ha, Sang-Ki 	APPROVED BY (QC)	Hong, Sang-Dea 
User					
ISSUED BY		CHECKED BY		APPROVED BY	

WISOL CO., LTD.
531-7, Gajang-ro, Osan-si,
Gyeonggi-do, KOREA, 18103
<http://www.wisol.co.kr>

▶ A TABLE OF CONTENTS

1. REVISION HISTORY	3
2. DEFINITION	4
3. PRECAUTIONS	4
4. OUTLINE DRAWING & DIMENSIONS	5
5. MARKING	6
6. PERFORMANCE	7
6-1. MAXIMUM RATINGS	7
6-2. ELECTRICAL CHARACTERISTICS	8
7. RELIABILITY	12
7-1. ENGINEERING SAMPLE FLOW CHART	12
7-2. TEST ITEM & CONDITION	13
8. REFLOW CONDITION	14
9. RECOMMENDED PCB DIMENSIONS	14
10. CAUTION	15
11. PACKING	16
11-1. DIMENSIONS	16
11-2. REELING QUANTITY	17
11-3. TAPING STRUCTURE	17
11-4. INNER BOX(Reel Packing) STRUCTURE	18
11-5. OUTER BOX STRUCTURE	19
12. TAPE SPECIFICATIONS	20
13. RoHS DATA	21

1. REVISION HISTORY

000	December 10, 2018	All Page	Make specification
-----	-------------------	----------	--------------------

2. DEFINITION

2-1. PART No.

S F X 707 B Y J 0 2

① ② ③ ④ ⑤ ⑥

No.	EXPLANATION
①	SAW Filter
②	Design Type
③	Center Frequency : Tx 707 MHz (699 ~ 716 MHz) Rx 737MHz (729 ~ 746 MHz)
④	Input:50ohm, Output:50ohm
⑤	Package size: 1.8×1.4mm ²
⑥	Design Revision (02 : Molding Type)

2-2. APPLICATION : Band-Pass Filter for B12

2-3. SPEC

ESD Level HBM = 250V

ESD Level MM = 150V

3. PRECAUTIONS

3-1. This device should not be used in any type of fluid such as water, oil, organic solvent, etc.

3-2. This is a hermetic device.

MSL(Moisture Sensitive Level) is the '2a' level.

3-3. Ultrasonic cleaning shall be avoided.

3-4. Isopropyl Alcohol and Ethyl Alcohol can be used for cleaning. Contact us before using other cleaning solvents than above

3-5. This is an electrostatic sensitive device.

Please avoid static voltage during operation and storage.

3-6. Sudden change of temperature shall be avoided, deterioration of the characteristics can occur.

3-7. If any malfunction due to designing or manufacturing which is out of specification occurs within one year after the products have been delivered, the maker should exchange the defective products.

4. OUTLINE DRAWING & DIMENSIONS

[Unit: mm]

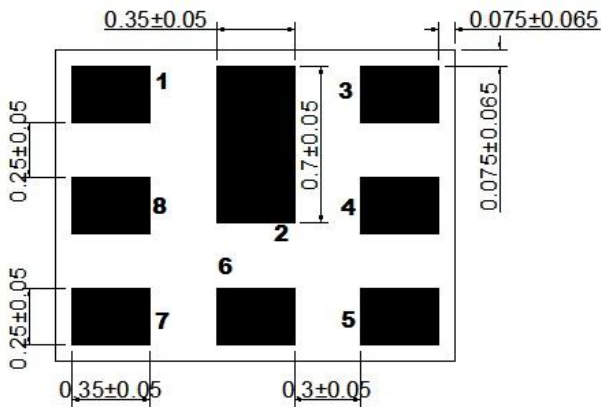
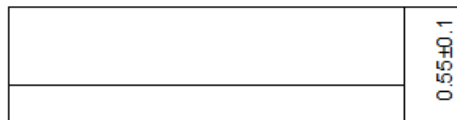
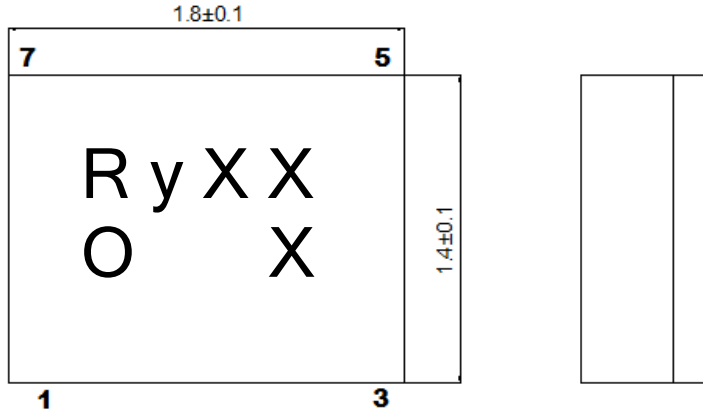

No.	Function
1	Rx Output
3	Tx Input
6	Antenna
2, 4, 5, 7, 8	GND

5. MARKING



5-1. R y X X X

- The 1st 2nd character 'Ry' indicates the model name of SAW Filter SFX707BYJ02.
- The 3rd character 'X' indicates the year and the month of manufacture..

Year	Month											
	1	2	3	4	5	6	7	8	9	10	11	12
2017	1	2	3	4	5	6	7	8	9	A	B	C
2018	D	E	F	G	H	I	J	K	L	M	N	O
2019	P	Q	R	S	T	U	V	W	X	Y	Z	a
2020	1	2	3	4	5	6	7	8	9	A	B	C

※ This rotates by the 3 years.

- The 4th, 5th character 'X' indicates Lot No.

5-2. ○

- This symbol indicates input pin 1.
- This indicates the producing center
 - : China

5-3. Marking : Laser Marking

6. PERFORMANCE

6-1. MAXIMUM RATINGS

CHARACTERISTICS	RATINGS	UNITS	NOTES
DC Permissive Voltage	5	V	
Input Power	30	dBm	55 °C, 5000 h
Operating Temperature Range	- 30 ~ +85	°C	
Storage Temperature Range	- 40 ~ +85	°C	

6-2. ELECTRICAL CHARACTERISTICS
6-2-1. TABLE

Ta = -30 ~ +85℃

Item	CONDITION [MHz]	UNIT	RATING		
			Min.	Typ.(25℃)	Max.
TX → ANTENNA					
Insertion Loss	699 ~ 716	dB	-	1.6	2.5
Inband Ripple	699 ~ 716	dB	-	0.9	1.9
VSWR(Tx)	699 ~ 716	-	-	1.6	2.2
Absolute Attenuation	10 ~ 650	dB	22	27	-
	729 ~ 746	dB	50	62	-
	746 ~ 768	dB	26	31	-
	869 ~ 894	dB	23	28	-
	1398 ~ 1432	dB	27	32	-
	1565.42 ~ 1605.89	dB	32	37	-
	1805 ~ 1880	dB	39	44	-
	1930 ~ 1990	dB	43	48	-
	2097 ~ 2155	dB	36	41	-
	2350 ~ 2360	dB	48	53	-
	2400 ~ 2484	dB	45	50	-
	2620 ~ 2690	dB	44	49	-
4900 ~ 5950	dB	22	27	-	
Termination Impedance : Tx / ANTENNA			50Ω(//10nH) / 50Ω(+ 10[nH])		
ANTENNA → RX					
Insertion Loss	729 ~ 746	dB	-	1.7	2.4
Inband Ripple	729 ~ 746	dB	-	0.6	1.2
VSWR(Rx)	729 ~ 746	-	-	1.7	2.2
Absolute Attenuation	10 ~ 699	dB	50	55	-
	699 ~ 716	dB	48	60	-
	776 ~ 793	dB	31	26	-
	824 ~ 849	dB	48	53	-
	1710 ~ 1755	dB	58	63	-
	1850 ~ 1920	dB	56	61	-
	2187 ~ 2238	dB	52	57	-
	2400 ~ 2500	dB	50	55	-
4900 ~ 5950	dB	32	37	-	
Termination Impedance : ANT / OUTPUT			50Ω (// 10[nH]) / 50Ω		

Item	CONDITION [MHz]	UNIT	RATING		
			Min.	Typ.(25℃)	Max.
TX → RX					
Isolation between Rx and Tx	699 ~ 716	dB	55	64	-
	729 ~ 746	dB	55	65	-

6-2-2. TEST FIXTURE

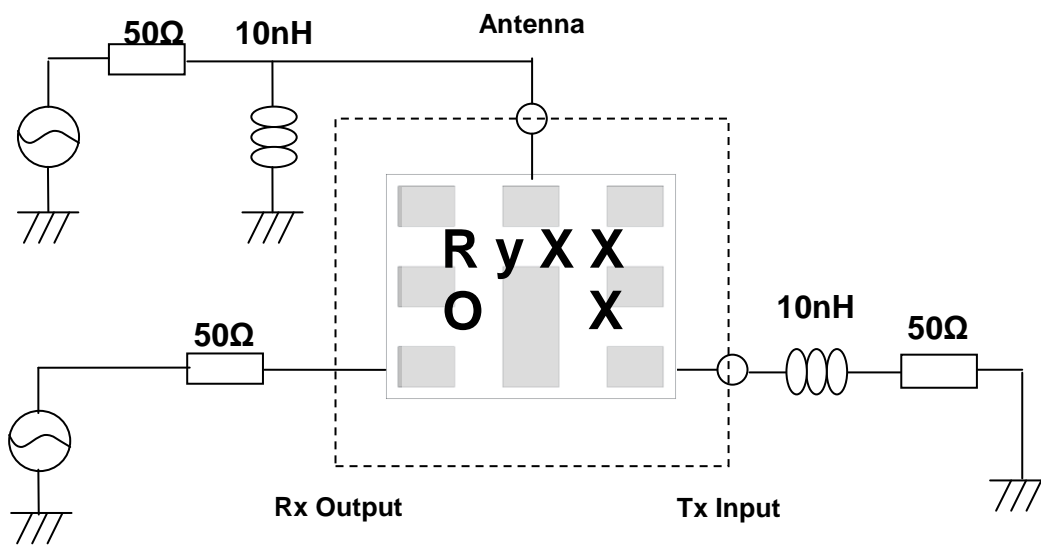

[X-Ray Top View]

6-2-3. GRAPH

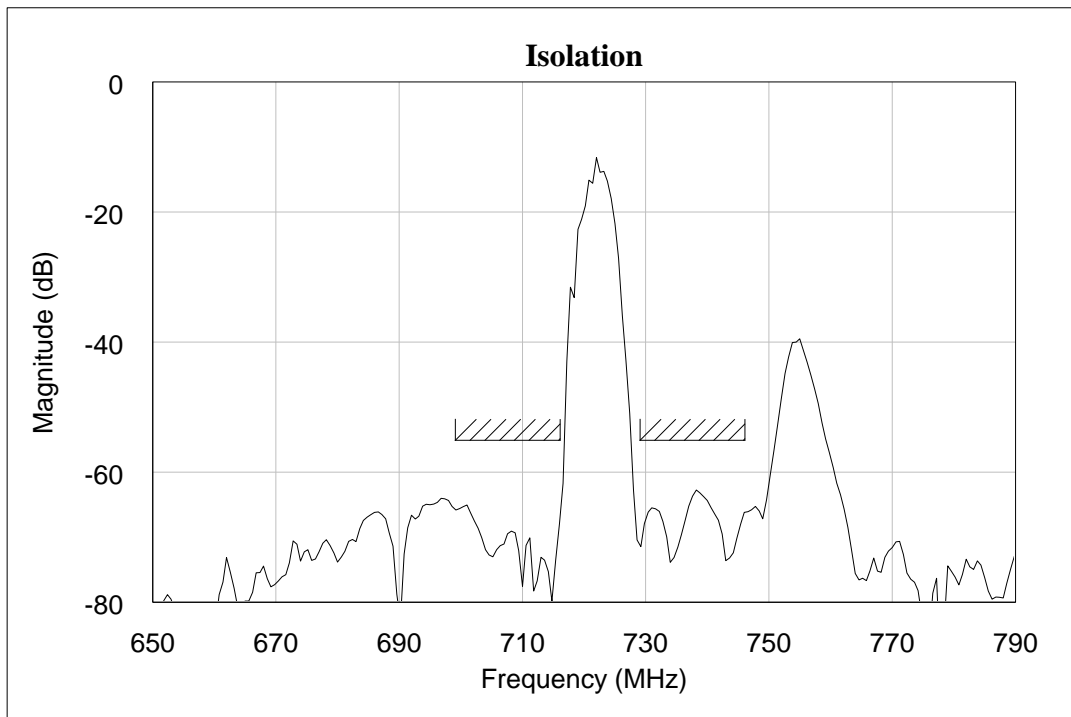
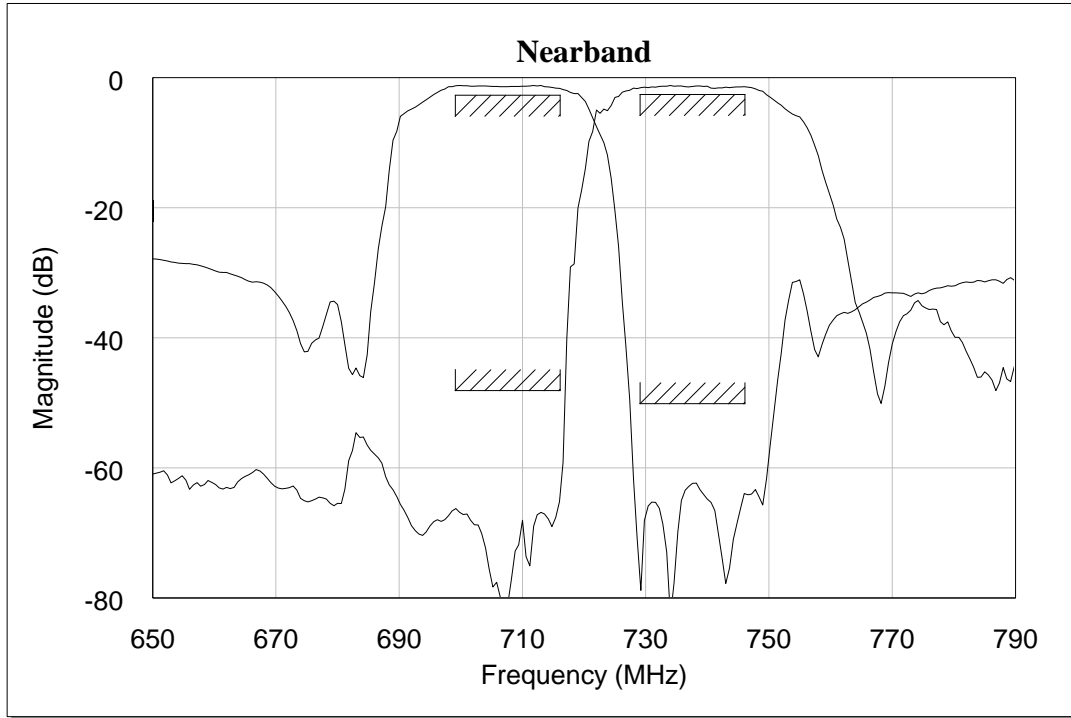

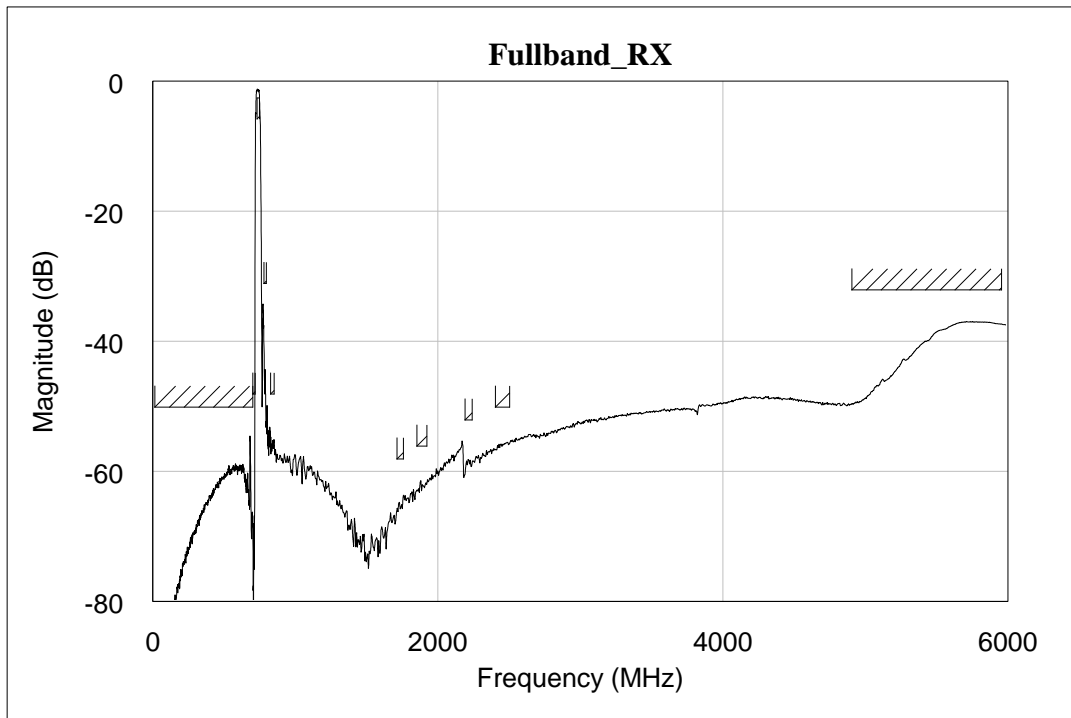
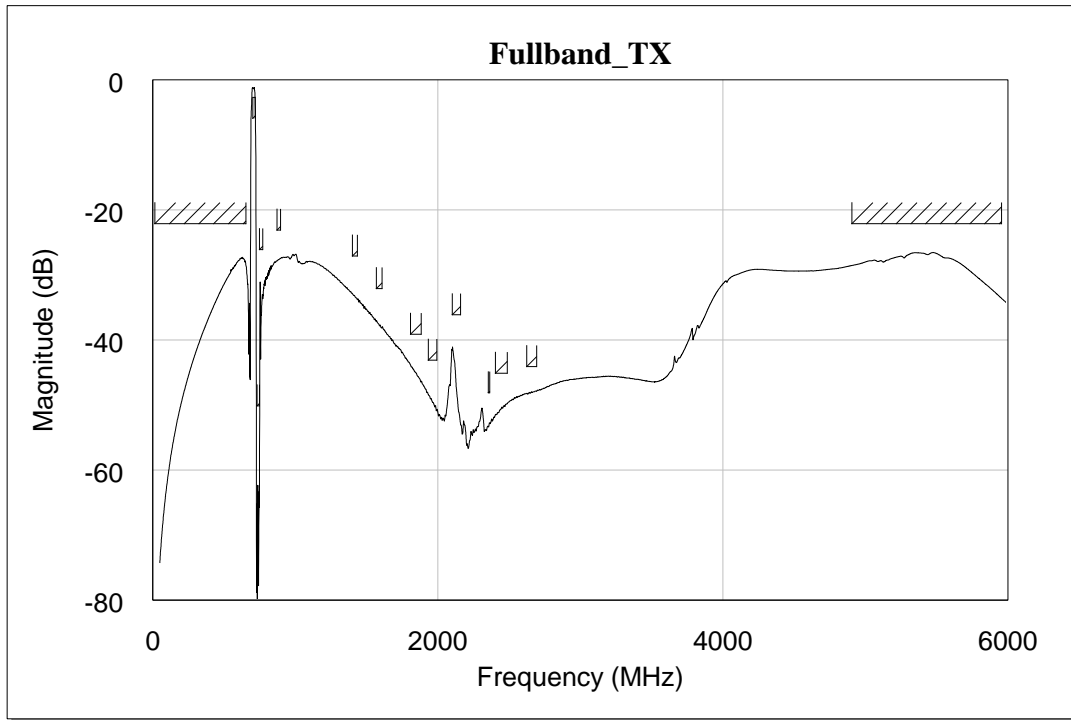

7. RELIABILITY

7-1. ENGINEERING SAMPLE FLOW CHART

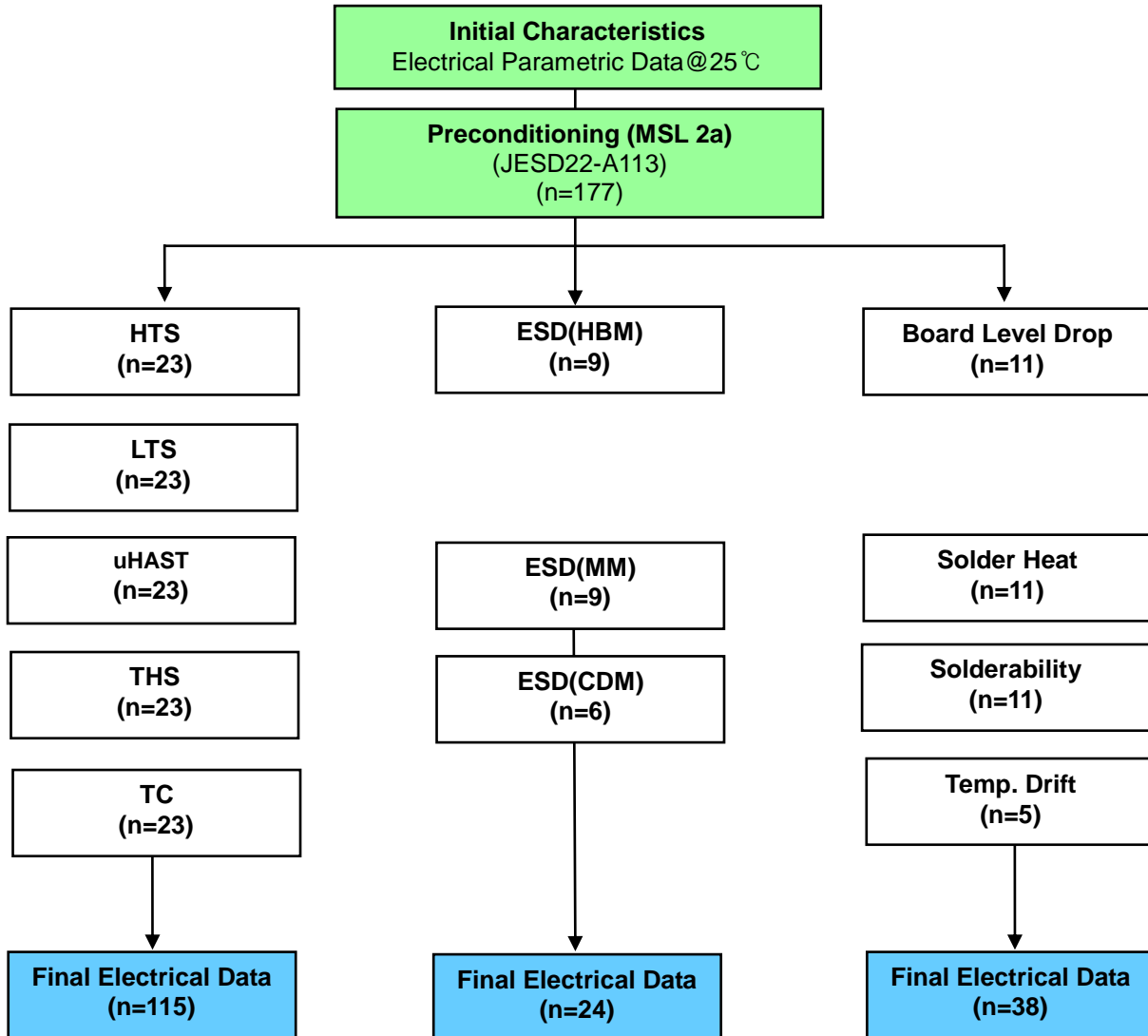

7-2. TEST ITEM & CONDITION

CATEGORY	TEST ITEM	TEST CONDITION	REMARK
	Preconditioning	Bake + Soak(MSL or above) + 3X Reflow duration (Soak 60°C 60% 120HR)	JESD22-A113



TEST ITEM	REMARK	TEST CONDITION	Duration
HTS (High Temperature Storage)	JESD22-A103	condition A +125(-10/+0)°C	1000hr
LTS (Low Temperature Storage)	JESD22-A119	condition A -40(-10/+0)°C	1000hr
uHAST (Unbiased HAST)	JESD22-A118	condition A 130±2°C, 85±5%, 33.3psi	96hr
THS (Temperature Humidity Storage)	JESD22-A101	85±2°C, 85±5% RH	1000hr
TC (Temperature Cycle)	JESD22-A104	condition B (-55°C⇔ +125°C) Soak mode 4 (30min)	500cycle
ESD(HBM)	JESD22-A114	200V, 250V, 300V	All pin 1sec 1time
ESD(MM)	JESD22-A115	100V 150V 200V	All pin 1sec 1time
ESD(CDM)	JESD22-C101	1.0KV, 1.2KV	All pin 1sec 1time
Board Level Drop Test	-	120 cm, 152 cm	12times 19times
Solder Heat Resistance	JESD22-B106C	260°C Solder Pore Dipping	10sec
Solderability	JESD22-B102E	235°C Solder Pore Dipping	3sec
Temp Drift		-40°C => 25°C => 125°C	조건당 2HR

8. REFLOW CONDITION

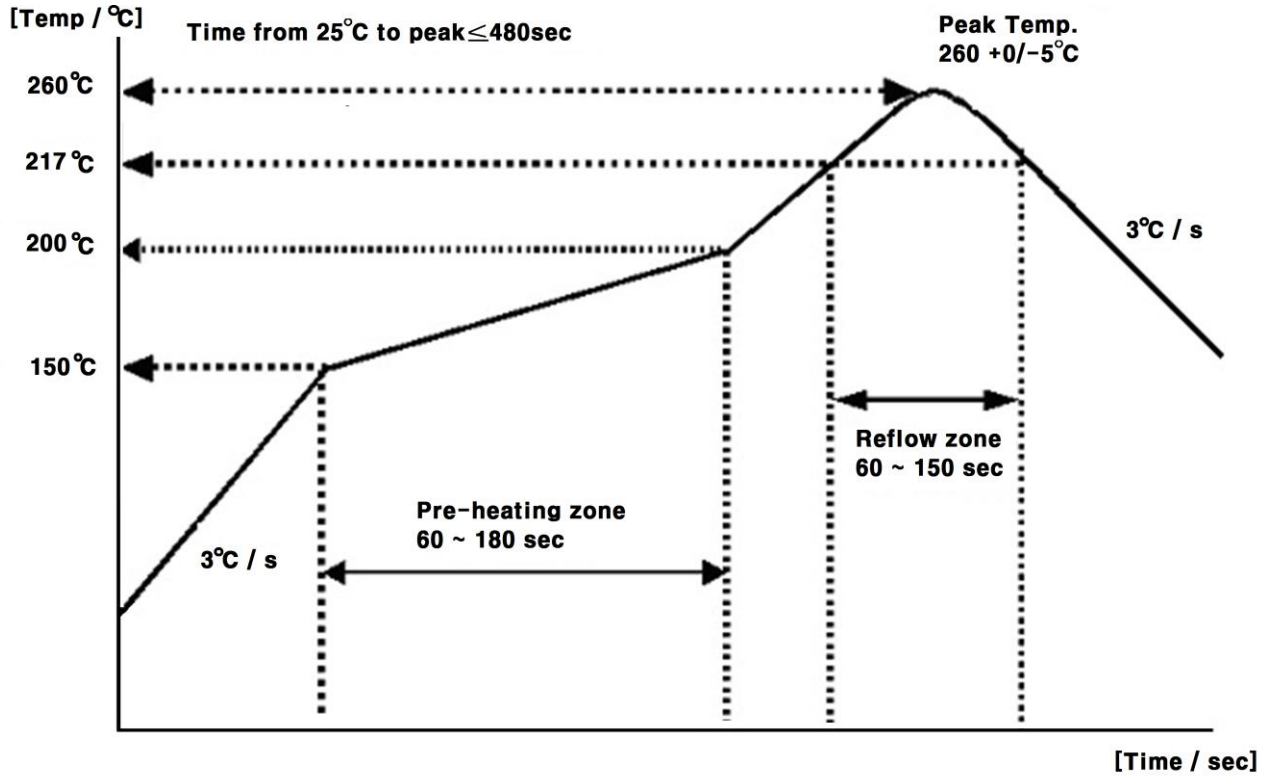

9. RECOMMENDED PCB DIMENSIONS

[unit : mm]

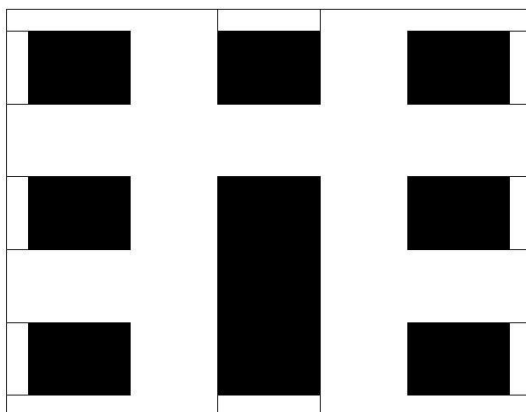

[SAW, X-ray Top view]

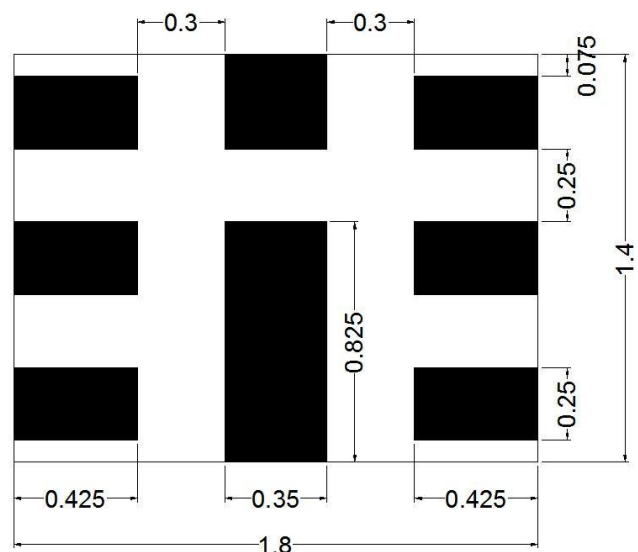

[PCB, X-ray Top view]

10. CAUTION

Moisture Sensitivity Device Caution (MSL LEVEL=2a)

1. Calculated shelf life in sealed bag : 12 month at < 40℃ and < 90% relative Humidity(RH)
 2. Peak package body temperature : **260℃**
 3. After bag is opened, devices that will be subjected to reflow solder or other high temperature process must be
 - (a) Mounted within : 672 hours of factory conditions ≤30℃/60% RH, or
 - (b) Stored per J-STD-033
 4. Device require bake, before mounting, if :
 - (a) Humidity Indicator Card reads > 60% when read at 23±5℃
 - (b) 3(a) or 3(b) are not met
 5. If baking is required, refer to IPC/JEDEC J-STD-033 for bake procedure
- Note : Level and body temperature defined by IPC/JEDEC J-STD-020

Aluminum Pack (310mmX370mm)



HIC(Humidity Indication Card)

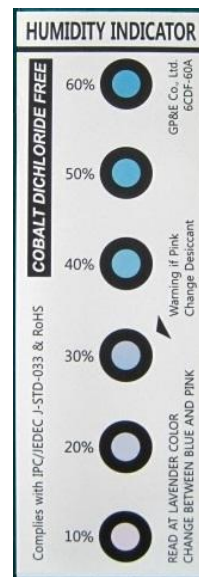

10 to 60% RH

11. PACKING

11-1. DIMENSIONS

- Carrier Tape

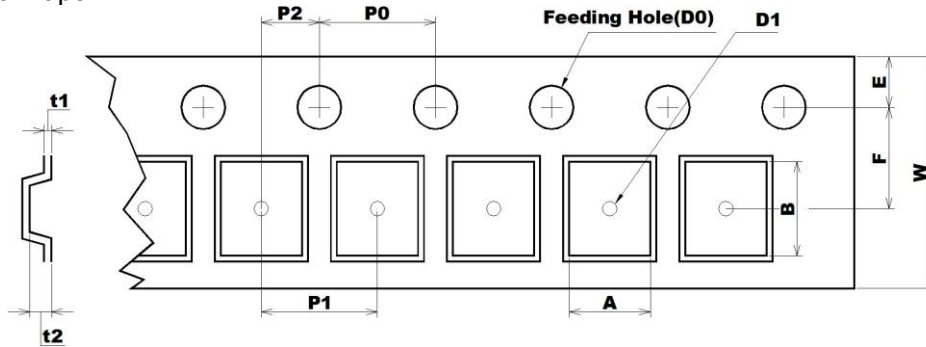

[Unit: mm]

A	B	D0	D1	E	F	P0	P1	P2	t1	t2	W
1.60	2.00	Ø1.55	Ø1.00	1.75	3.50	4.00	4.00	2.00	0.25	0.80	8.00
+0.05	+0.05	+0.05	MIN	+0.10	+0.05	+0.10	+0.10	+0.05	+0.05	+0.05	+0.10
-0.05	-0.05	-0.05	-	-0.10	-0.05	-0.10	-0.10	-0.05	-0.05	-0.05	-0.10

- Reel

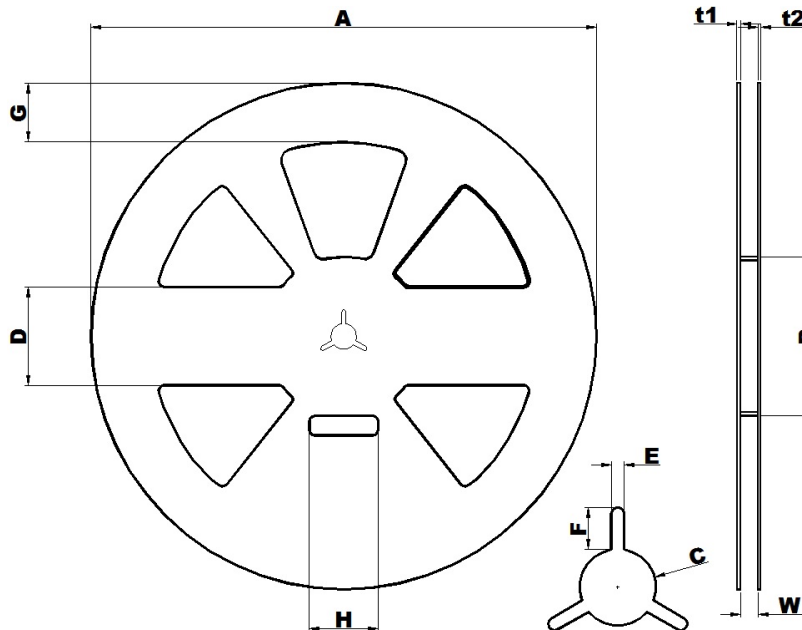

[Unit: mm]

A	B	C	D	E	F	G	H	t1	t2	W
Ø258.0	Ø81.0	Ø13.0	50.0	2.2	7.0	30.0	35.0	1.8	1.5	9.0
+1.0	+1.0	+0.5	+0.8	+0.3	+0.5	+0.8	+1.0	+0.5	+0.5	+1.0
-0.5	-1.0	-0.5	-0.8	-0.3	-0.5	-0.8	-1.0	-0.5	-0.5	-0.5

- The product shall be packed properly not to damaged during transportation and storage.

11-2. REELING QUANTITY

10 inch reel : 8,000 pcs/reel

11-3. TAPING STRUCTURE

11-3-1. The tape shall be wound around the reel in direction shown below.

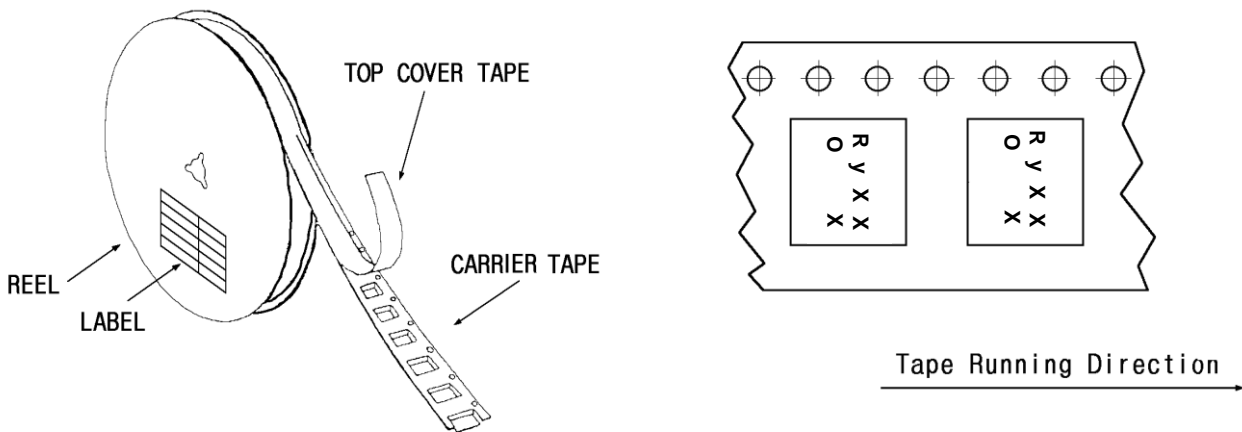

11-3-2. BARCODE LABEL

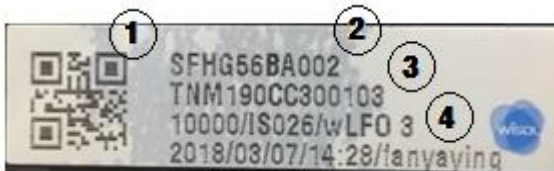

①	MODEL NAME BARCODE
②	Model Name
③	Reel number
④	Quantity / Marking

1-3-3. Leader part and vacant position specifications.

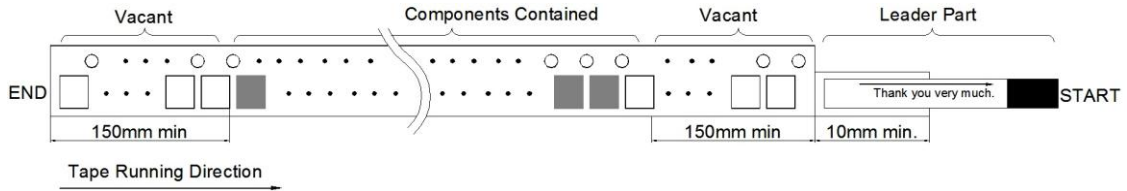

11-4. INNER BOX(Reel Packing) STRUCTURE

Material: Polycarbonate

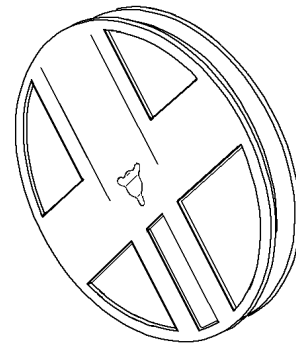

Material : Polyethylene + Aluminium
Size : 310×370mm²

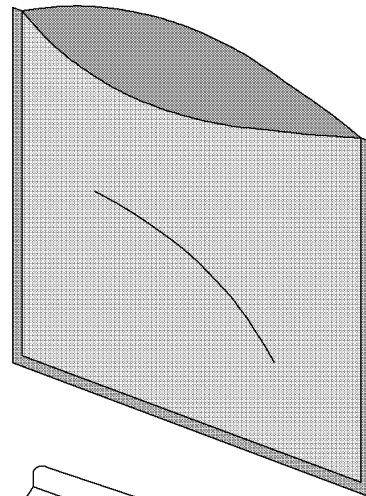

Material : Paper
Size: (D)260×(W)37×(H)265mm³

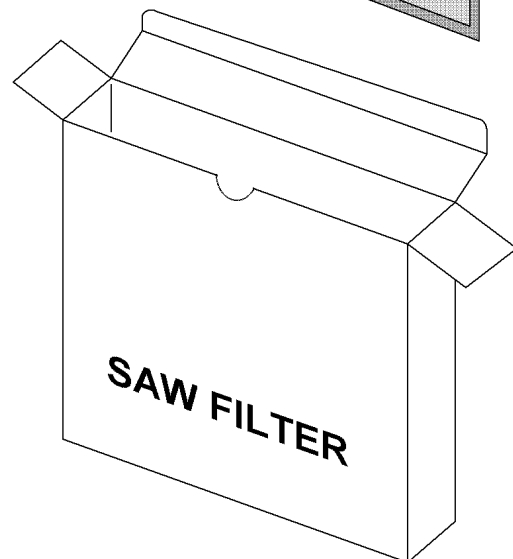

11-5. OUTER BOX STRUCTURE

Material : Paper

TYPE	SIZE(mm)			Inner Box #
	a	b	c	
A	270	240	275	6 boxes

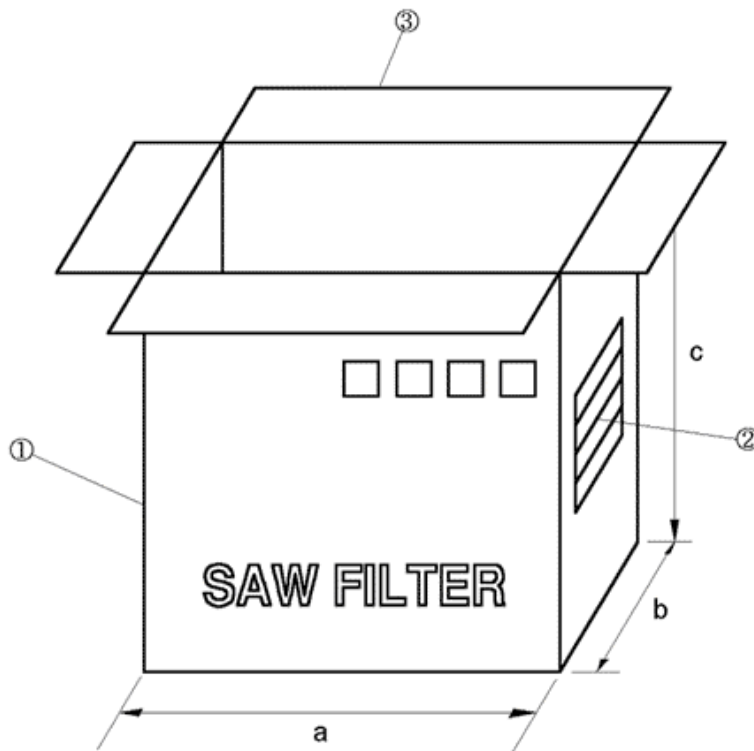

SIDE ①

SIDE ②

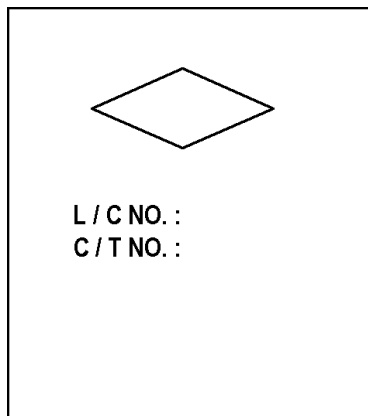

MODEL	
Q'TY	EA
USER	
DATE	. .

- SIDE is the same as front side.

12. TAPE SPECIFICATIONS

12-1. Tensile Strength of Carrier Tape: 4.4N/mm width

12-2. Top Cover Tape Adhesion (See the below figure)

- pull of angle: 0~15 degree
- speed: 300mm/min.
- force: 20~70g

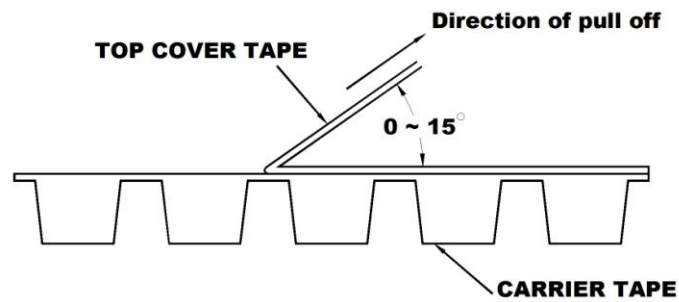

13. RoHS DATA



Test Report No. F690101/LF-CTSAYAA18-56872

Issued Date : 2018. 10. 30

Page 1 of 7

WISOL CO., LTD.

28-40, Gajangsaneopdong-ro
Osan-si, Gyeonggi-do
Korea



The following sample(s) was/were submitted and identified by/on behalf of the client as:-

SGS File No. : AYAA18-56872
Product Name : SAW FILTER(A2029)
Item No./Part No. : N/A
Buyer(s) : SAMSUNG
Received Date : 2018. 10. 25
Test Period : 2018. 10. 25 to 2018. 10. 30
Test Comments : By the applicant's specific request, the sampling and testing was performed only for the part indicated in the photo without disassembly.
Test Results : For further details, please refer to following page(s)

SGS Korea Co., Ltd.



Jeff Jang / Chemical Lab Mgr

This document is prepared by the Company subject to its General Conditions of Service printed overleaf, available on request or accessible at <http://www.sgs.com/en/terms-and-conditions.aspx> and, for the documents, subject to Terms and Conditions for Electronic Documents at <http://www.sgs.com/en/terms-and-conditions.aspx>. Attention is drawn to the limitation of liability, indemnification and jurisdiction issues defined therein. Any holder of this document is advised that information contained herein reflects the Company's findings at the time of its intervention only and within the limits of Client's instructions, if any. The Company's sole responsibility is to its Client and this document does not constitute any assurance from exercising all their rights and obligations under the transaction documents. This document cannot be reproduced except in full, without prior written approval of the Company. Any unauthorized alteration, forgery or falsification of the content or appearance of this document is unlawful and offenders may be prosecuted to the fullest extent of the law. Unless otherwise specified, the results shown in this test report refer only to the sample(s).



SGS Korea Co., Ltd.

322, The O valley, 76, LS-ro, Dongan-gu, Anyang-si, Gyeonggi-do, Korea 14117
 t +82 (0)31 4808 000 f +82 (0)31 4808 050 <http://www.sgsgroup.kr>

Member of the SGS Group (Société Générale de Surveillance)



Test Report No. F690101/LF-CTSAYAA18-56872

Issued Date : 2018. 10. 30

Page 2 of 7

Sample No. : AYAA18-56872.001
Sample Description : SAW FILTER(A2029)
Item No./Part No. : N/A
Materials : HTCC. GOLD, EPOXY(A2029), LT

Heavy Metals

Test Items	Unit	Test Method	MDL	Results
Cadmium (Cd)	mg/kg	With reference to IEC 62321-5:2013 (Determination of Cadmium by ICP-OES)	0.5	N.D.
Lead (Pb)	mg/kg	With reference to IEC 62321-5:2013 (Determination of Lead by ICP-OES)	5	N.D.
Mercury (Hg)	mg/kg	With reference to IEC 62321-4:2013 (Determination of Mercury by ICP-OES)	2	N.D.
Hexavalent Chromium (Cr VI)*	mg/kg	With reference to IEC 62321-7-2:2017, determination of Hexavalent Chromium by Colorimetric Method using UV-Vis and/or with reference to IEC 62321-5:2013, determination of Chromium by ICP-OES.	8	N.D.
Antimony (Sb)	mg/kg	With reference to EPA 3052(1996), US EPA 6010B(1996), ICP	10	N.D.

Flame Retardants-PBBs/PBDEs

Test Items	Unit	Test Method	MDL	Results
Monobromobiphenyl	mg/kg	With reference to IEC 62321-6:2015 (Determination of PBBs and PBDEs by GC-MS)	5	N.D.
Dibromobiphenyl	mg/kg	With reference to IEC 62321-6:2015 (Determination of PBBs and PBDEs by GC-MS)	5	N.D.
Tribromobiphenyl	mg/kg	With reference to IEC 62321-6:2015 (Determination of PBBs and PBDEs by GC-MS)	5	N.D.
Tetrabromobiphenyl	mg/kg	With reference to IEC 62321-6:2015 (Determination of PBBs and PBDEs by GC-MS)	5	N.D.
Pentabromobiphenyl	mg/kg	With reference to IEC 62321-6:2015 (Determination of PBBs and PBDEs by GC-MS)	5	N.D.
Hexabromobiphenyl	mg/kg	With reference to IEC 62321-6:2015 (Determination of PBBs and PBDEs by GC-MS)	5	N.D.
Heptabromobiphenyl	mg/kg	With reference to IEC 62321-6:2015 (Determination of PBBs and PBDEs by GC-MS)	5	N.D.
Octabromobiphenyl	mg/kg	With reference to IEC 62321-6:2015 (Determination of PBBs and PBDEs by GC-MS)	5	N.D.
Nonabromobiphenyl	mg/kg	With reference to IEC 62321-6:2015 (Determination of PBBs and PBDEs by GC-MS)	5	N.D.
Decabromobiphenyl	mg/kg	With reference to IEC 62321-6:2015 (Determination of PBBs and PBDEs by GC-MS)	5	N.D.
Monobromodiphenyl ether	mg/kg	With reference to IEC 62321-6:2015 (Determination of PBBs and PBDEs by GC-MS)	5	N.D.

This document is issued by the Company subject to its General Conditions of Service printed overleaf, available on request or accessible at <http://www.sgs.com/en/terms-and-conditions.aspx> and, for electronic format documents, subject to Terms and Conditions for Electronic Documents at www.sgs.com/terms_e-document.htm - http://www.sgs.com/terms_e-document.htm. Attention is drawn to the limitation of liability, indemnification and jurisdiction issues defined therein. Any holder of this document is advised that information contained herein reflects the Company's findings at the time of its intervention only and within the limits of Client's instructions, if any. The Company's sole responsibility is to its Client and this document does not exonerate parties to a transaction from exercising all their rights and obligations under the transaction documents. This document cannot be reproduced except in full, without prior written approval of the Company. Any unauthorized alteration, forgery or falsification of the content or appearance of this document is unlawful and offenders may be prosecuted to the fullest extent of the law. Unless otherwise stated the results shown in this test report refer only to the sample(s).

*401 Version4

SGS Korea Co., Ltd.

322, The O valley, 76, LS-ro, Dongan-gu, Anyang-si, Gyeonggi-do, Korea 14117
 t +82 (0)31 4808 000 f +82 (0)31 4808 050 <http://www.sgsgroup.kr>

Member of the SGS Group (Société Générale de Surveillance)



Test Report No. F690101/LF-CTSAYAA18-56872

Issued Date : 2018. 10. 30

Page 3 of 7

Sample No. : AYAA18-56872.001
Sample Description : SAW FILTER(A2029)
Item No./Part No. : N/A
Materials : HTCC, GOLD, EPOXY(A2029), LT

Flame Retardants-PBBs/PBDEs

Test Items	Unit	Test Method	MDL	Results
Dibromodiphenyl ether	mg/kg	With reference to IEC 62321-6:2015 (Determination of PBBs and PBDEs by GC-MS)	5	N.D.
Tribromodiphenyl ether	mg/kg	With reference to IEC 62321-6:2015 (Determination of PBBs and PBDEs by GC-MS)	5	N.D.
Tetrabromodiphenyl ether	mg/kg	With reference to IEC 62321-6:2015 (Determination of PBBs and PBDEs by GC-MS)	5	N.D.
Pentabromodiphenyl ether	mg/kg	With reference to IEC 62321-6:2015 (Determination of PBBs and PBDEs by GC-MS)	5	N.D.
Hexabromodiphenyl ether	mg/kg	With reference to IEC 62321-6:2015 (Determination of PBBs and PBDEs by GC-MS)	5	N.D.
Heptabromodiphenyl ether	mg/kg	With reference to IEC 62321-6:2015 (Determination of PBBs and PBDEs by GC-MS)	5	N.D.
Octabromodiphenyl ether	mg/kg	With reference to IEC 62321-6:2015 (Determination of PBBs and PBDEs by GC-MS)	5	N.D.
Nonabromodiphenyl ether	mg/kg	With reference to IEC 62321-6:2015 (Determination of PBBs and PBDEs by GC-MS)	5	N.D.
Decabromodiphenyl ether	mg/kg	With reference to IEC 62321-6:2015 (Determination of PBBs and PBDEs by GC-MS)	5	N.D.

Halogen Content

Test Items	Unit	Test Method	MDL	Results
Bromine(Br)	mg/kg	With reference to EN 14582:2016, IC	30	N.D.
Chlorine(Cl)	mg/kg	With reference to EN 14582:2016, IC	30	N.D.

- NOTE:**
- (1) N.D. = Not detected.(<MDL)
 - (2) mg/kg = ppm
 - (3) MDL = Method Detection Limit
 - (4) - = No regulation
 - (5) Negative = Undetectable / Positive = Detectable
 - (6) ** = Qualitative analysis (No Unit)
 - (7) * = a. The result of Hexavalent Chromium (Cr(VI)) is "ND" as the result of Chromium (Cr) is "ND", and confirmation test of Hexavalent Chromium (Cr(VI)) is not required.
 b. If the Chromium (Cr) content is greater than the MDL of Hexavalent Chromium (Cr(VI)), confirmation test of Hexavalent Chromium (Cr(VI)) is required.

This document is issued by the Company subject to its General Conditions of Service printed overleaf, available on request or accessible at <http://www.sgs.com/asi/Terms-and-Conditions.aspx>, or for electronic format documents, subject to Terms and Conditions for Electronic Documents at www.sgs.com/terms_e-document.htm or http://www.sgs.com/terms_e-document.htm. Attention is drawn to the limitation of liability, indemnification and jurisdiction issues defined therein. Any holder of this document is advised that information contained hereon reflects the Company's findings at the time of its intervention only and within the limits of Client's instructions, if any. The Company's sole responsibility is to its Client and this document does not constitute a transaction from exercising all their rights and obligations under the transaction documents. This document cannot be reproduced except in full, without prior written approval of the Company. Any unauthorized alteration, forgery or falsification of the content or appearance of this document is unlawful and offenders may be prosecuted to the fullest extent of the law. Unless otherwise stated the results shown in this test report refer only to the sample(s).

401 Version4

SGS Korea Co., Ltd.

322, The O valley, 76, LS-ro, Dongan-gu, Anyang-si, Gyeonggi-do, Korea 14117
 t +82 (0)31 4608 000 f +82 (0)31 4608 059 <http://www.sgsgroup.kr>

Member of the SGS Group (Société Générale de Surveillance)



Test Report No. F690101/LF-CTSAYAA18-56872

Issued Date : 2018. 10. 30

Page 4 of 7

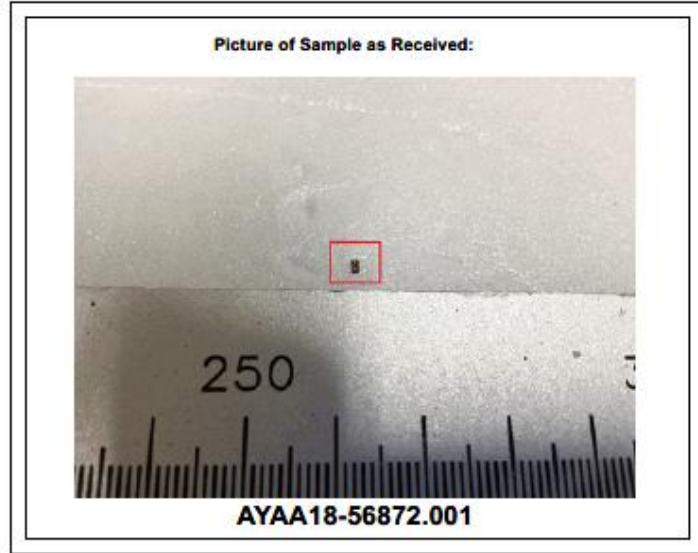

This document is issued by the Company subject to its General Conditions of Service printed overleaf, available on request or accessible at <http://www.sgs.com/sgs/terms-and-conditions.aspx> and, for electronic format documents, subject to Terms and Conditions for Electronic Documents at www.sgs.com/terms-and-conditions.aspx. Attention is drawn to the limitation of liability, indemnification and jurisdiction issues defined therein. Any holder of this document is advised that information contained herein reflects the Company's findings at the time of its intervention only and within the limits of Client's instructions, if any. The Company's sole responsibility is to its Client and this document does not exonerate parties to a transaction from exercising all their rights and obligations under the transaction documents. This document cannot be reproduced except in full, without prior written approval of the Company. Any unauthorized alteration, forgery or falsification of the content or appearance of this document is unlawful and offenders may be prosecuted to the fullest extent of the law. Unless otherwise stated the results shown in this test report refer only to the sample(s).

401 Version4

SGS Korea Co., Ltd.

322, The O valley, 76, LS-ro, Dongan-gu, Anyang-si, Gyeonggi-do, Korea 14117
t +82 (0)31 4808 000 f +82 (0)31 4808 059 <http://www.sgsgroup.kr>

Member of the SGS Group (Societăți Găminale de Supraveghere)



Test Report No. F690101/LF-CTSAYAA18-56872

Issued Date : 2018. 10. 30

Page 5 of 7

Testing Flow Chart for RoHS: Cd/Pb/Hg/Cr⁶⁺ /PBBs&PBDEs Testing

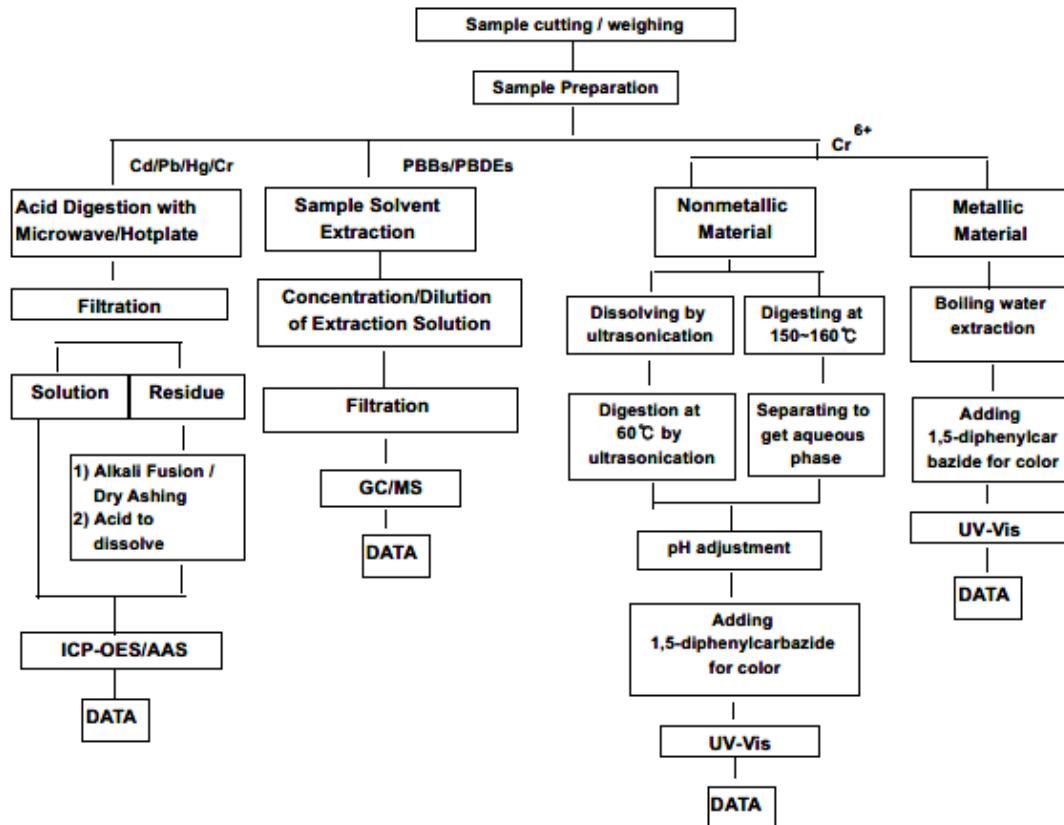

The samples were dissolved totally at the acid digestion step of the above flow chart for Cd,Pb,Hg
 Section Chief : Minkyu Park

This document is issued by the Company subject to its General Conditions of Service printed overleaf, available on request or accessible at <http://www.sgs.com/en/Terms-and-Conditions.aspx> and, for electronic format documents, subject to Terms and Conditions for Electronic Documents at www.sgs.com/terms_e-document.htm and http://www.sgs.com/terms_e-document.htm. Attention is drawn to the limitation of liability, indemnification and jurisdiction issues defined therein. Any holder of this document is advised that information contained herein reflects the Company's findings at the time of its intervention only and within the limits of Client's instructions, if any. The Company's sole responsibility is to its Client and this document does not exonerate parties to a transaction from exercising all their rights and obligations under the transaction documents. This document cannot be reproduced except in full, without prior written approval of the Company. Any unauthorized alteration, forgery or falsification of the content or appearance of this document is unlawful and offenders may be prosecuted to the fullest extent of the law. Unless otherwise stated the results shown in this test report refer only to the sample(s).

*401 Version4

SGS Korea Co., Ltd.

322, The O valley, 76, LS-ro, Dongan-gu, Anyang-si, Gyeonggi-do, Korea 14117
 t +82 (0)31 4608 000 f +82 (0)31 4608 050 <http://www.sgsgroup.kr>

Member of the SGS Group (Société Générale de Surveillance)



Test Report No. F690101/LF-CTSAYAA18-56872

Issued Date : 2018. 10. 30

Page 6 of 7

Flow Chart for Inorganic Elements Testing

Inorganic Elements

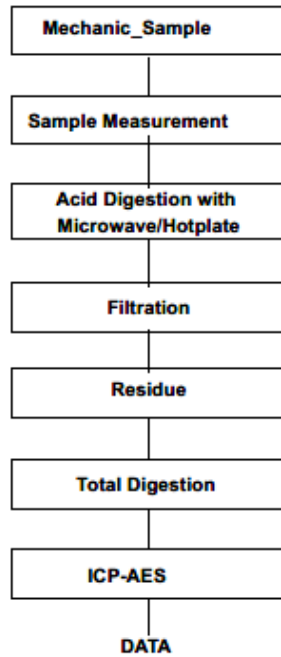

Major Inorganic Heavy Metals	Antimony(Sb) , Beryllium(Be) , Phosphorus(P) , Arsenic(As) etc.
------------------------------	---

This document is issued by the Company subject to its General Conditions of Service printed overleaf, available on request or accessible at <http://www.sgs.com/asi/Terms-and-Conditions.aspx> and, for electronic format documents, subject to Terms and Conditions for Electronic Documents at www.sgs.com/terms_e-document.htm and http://www.sgs.com/terms_e-document.htm. Attention is drawn to the limitation of liability, indemnification and jurisdiction issues defined therein. Any holder of this document is advised that information contained hereon reflects the Company's findings at the time of its intervention only and within the limits of Client's instructions, if any. The Company's sole responsibility is to its Client and this document does not exonerate parties to a transaction from exercising all their rights and obligations under the transaction documents. This document cannot be reproduced except in full, without prior written approval of the Company. Any unauthorized alteration, forgery or falsification of the content or appearance of this document is unlawful and offenders may be prosecuted to the fullest extent of the law. Unless otherwise stated the results shown in this test report refer only to the sample(s).

401 Version4

SGS Korea Co., Ltd.

322, The O valley, 76, LS-ro, Dongan-gu, Anyang-si, Gyeonggi-do, Korea 14117
 t +82 (0)31 4608 000 f +82 (0)31 4608 050 <http://www.sgsgroup.kr>

Member of the SGS Group (Société Générale de Surveillance)



Test Report No. F690101/LF-CTSAYAA18-56872

Issued Date : 2018. 10. 30

Page 7 of 7

Flow Chart for Halogen Test

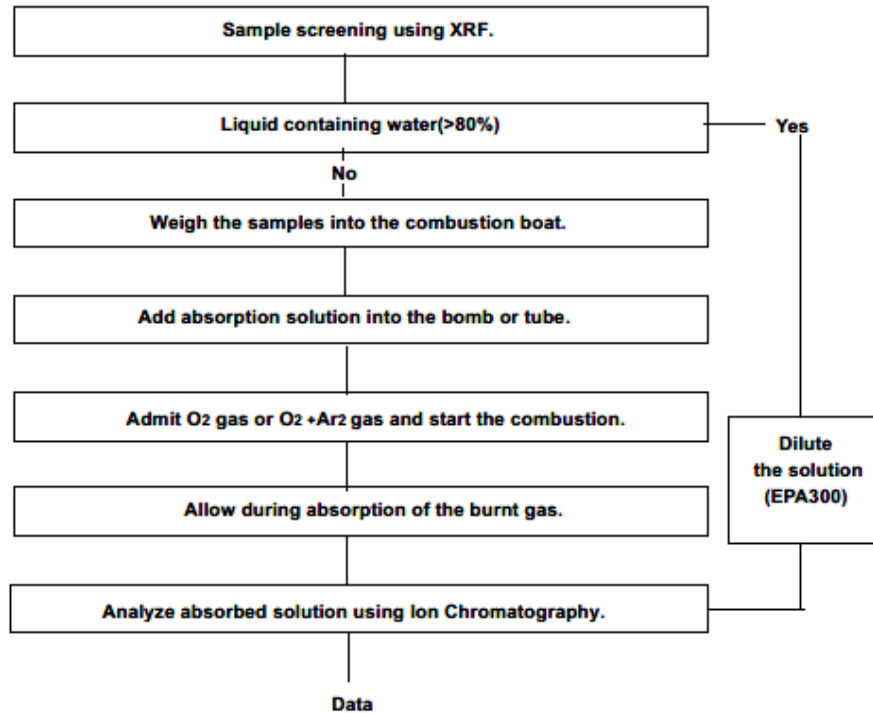

*** End of Report ***

This document is issued by the Company subject to its General Conditions of Service printed overleaf, available on request or accessible at <http://www.sgs.com/kr/Terms-and-Conditions.aspx> and, for electronic format documents, subject to Terms and Conditions for Electronic Documents at www.sgs.com/kr/terms_e-document.htm. Attention is drawn to the limitation of liability, indemnification and jurisdiction issues defined therein. Any holder of this document is advised that information contained herein reflects the Company's findings at the time of its intervention only and within the limits of Client's instructions, if any. The Company's sole responsibility is to its Client and this document does not exonerate parties to a transaction from exercising all their rights and obligations under the transaction documents. This document cannot be reproduced except in full, without prior written approval of the Company. Any unauthorized alteration, forgery or falsification of the content or appearance of this document is unlawful and offenders may be prosecuted to the fullest extent of the law. Unless otherwise stated the results shown in this test report refer only to the sample(s).

401 Version4

SGS Korea Co., Ltd. 322, The O valley, 76, LS-ro, Dongan-gu, Anyang-si, Gyeonggi-do, Korea 14117
 t +82 (0)31 4608 000 f +82 (0)31 4608 050 <http://www.sgsgroup.kr>

Member of the SGS Group (Société Générale de Surveillance)

X-ON Electronics

Largest Supplier of Electrical and Electronic Components

Click to view similar products for [Signal Conditioning](#) category:

Click to view products by [WISOL](#) manufacturer:

Other Similar products are found below :

[PD0409J5050S2HF](#) [HHS-109-PIN](#) [AFS14A35-1591.50-T3](#) [JP510S](#) [LFB322G45SN1A504](#) [SF2159E](#) [FM-104-PIN](#) [CER0813B](#)
[MAPDCC0005](#) [3A325](#) [BD0810N50100AHF](#) [DC0710J5005AHF](#) [DC2327J5005AHF](#) [LFL15869MTC1B787](#) [X3C19F1-20S](#)
[CDBLB455KCAX39-B0](#) [RF1353C](#) [051157-0000](#) [PD0922J5050D2HF](#) [600S150FTRB](#) [1E1305-3](#) [1F1304-3S](#) [TP-103-PIN](#)
[BD1222J50200AHF](#) [BD1722J50100AHF](#) [2450DP39K5400E](#) [BD0810J50150AHF](#) [BD1722J50200AHF](#) [DS-327-PIN](#) [MACP-008125-](#)
[CK07F0](#) [DS-329-PIN](#) [DS-313-PIN](#) [TP-104-PIN](#) [TP-101-PIN](#) [HH-128-PIN](#) [8594810000](#) [T-1000-N](#) [JP506S](#) [XC0900P-10S](#) [XC0900B-30S](#)
[CHE1260-QAG](#) [11305-10](#) [5962-9091202MXA](#) [3A412S](#) [X3C06A4-03S](#) [B39000Z3410A4](#) [DSS-333-PIN](#) [PD2425J5050S2HF](#)
[B39242B4360P810](#) [B39781B8005P810](#)