

WizFi310 Datasheet

Version 1.0.0

WizFi310

WizFi310 is a small size wireless module for the highest level of integration, featuring 802.11b/g and 802.11n.

It has onboard antenna, and external antenna interface, RF output PIN also exist in the board.

WizFi310 internally integrated TCP / IP protocol stack, supporting numerous protocols such as ARP, IP, ICMP, TCP, UDP, DHCP CLIENT, DHCP SERVER, DNS and other etc. It supports AP mode, Station mode. It also support rich AT commands for most kinds of application needs. Users can easily and quickly use it on wifi networking and data transmission. The baud rate of module serial port up to 921600bps, which can fully meet on low-rate applications.

In networking part, WizFi310 supports network parameters storage in the module that reduces time to connect to network. The module has built-in WEB server, supporting wireless network parameters configuration and wireless firmware upgrade. It also supports WPS. For application protocols, MQTT and SSL were supported in this module.

For software and driver development, WIZnet provides extensive technical documents and reference software codes for system integration.

Features

Application

- UART serial AT command set operation
- Support for multiple baud rate
- Support wireless configuration and OTA firmware upgrade
- Support on fast networking application functions (WPS function)
- Support MQTT, GMMP, TLS applications protocols

Standards Supported

- 802.11b/g/n compatible WLAN
- Light Weight TCP/IP protocol
- WPA, WPA2, Open, shared key
- WPS support

WLAN MAC Features

- CMOS MAC, Baseband PHY, and RF in a single chip for 802.11b/g/n compatible WLAN
- Complete 802.11n solution for 2.4GHz band
- 72.2Mbps receive PHY rate and 72.2Mbps transmit PHY rate using 20MHz bandwidth
- 150Mbps receive PHY rate and 150Mbps transmit PHY rate using 40MHz bandwidth
- PHY- level spoofing to enhance legacy compatibility
- Power saving mechanism

WLAN PHY Features

- 802.11n OFDM
- One Transmit and one Receive path (1T1R)
- Short Guard Interval (400ns)
- DSSS with DBPSK and DQPSK, CCK modulation with long and short preamble
- Maximum data rate 54Mbps in 802.11g and 150Mbps in 802.11n
- Fast receiver Automatic Gain Control (AGC)

Block Diagram

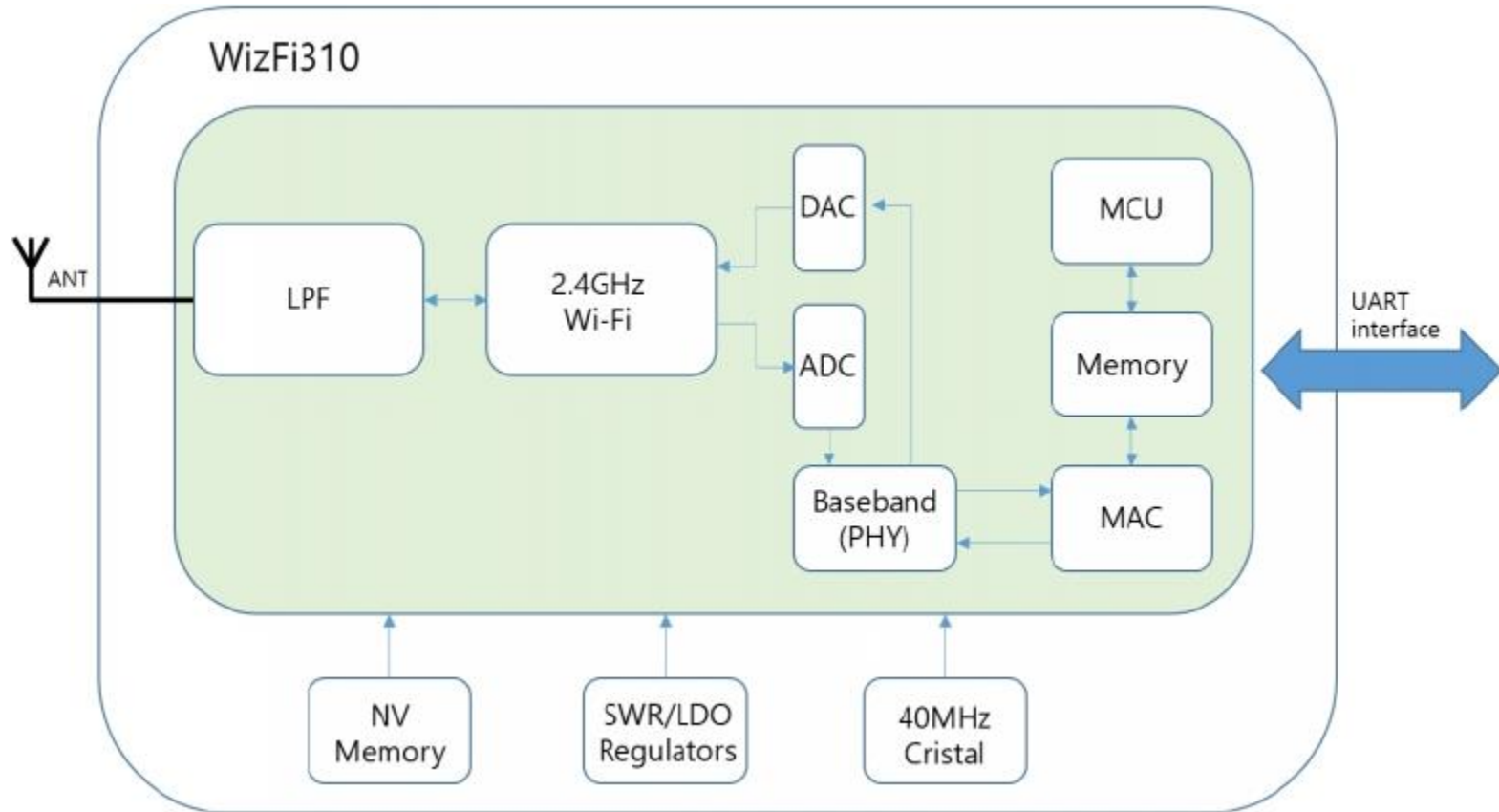

Table of Contents

1	Pin Assignment	7
1.1	Pin Map	7
1.2	Pin Description	8
2	Electrical Specification	10
2.1	General specification	10
2.2	802.11g Mode.....	11
2.3	802.11g HT 20 Mode	12
2.4	802.11g HT 40 Mode	13
2.6	NVM specification	13
2.7	Power Consumption	14
3	Dimensions	15
4	Reference schematic	16

Table of Figures

Figure 1. WizFi301 Pin Layout	7
Figure 2. Dimensions	15
Figure 3. Reference schematic	16

1 Pin Assignment

1.1 Pin Map

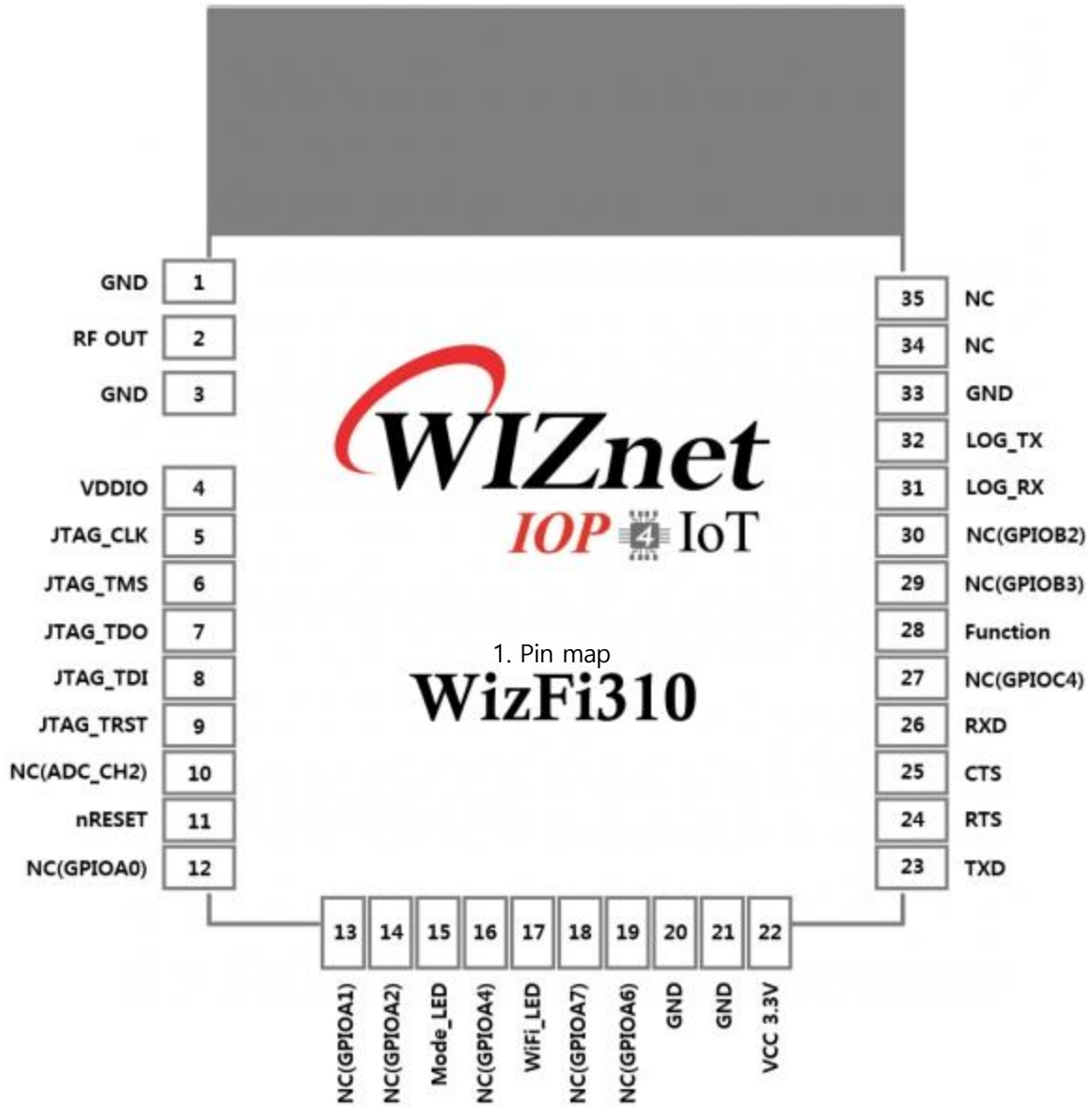

Figure 1. WizFi310 Pin Layout

1.2 Pin description

Table 2. WizFi310 Pin Description

Pin No	Name	Type	Description
1	GND	-	Ground
2	RF_OUT	-	2.4GHz RF output
3	GND	-	Ground
4	VDDIO	-	3.3V for Digital IO or Digital blocksd
5	JTAG_CLK	-	For normal operation, if JTAG is not used, this pin can be lenft unconnected (NC)
6	JTAG_TMS	-	For normal operation, if JTAG is not used, this pin can be left unconnected (NC)
7	JTAG_TDO	-	For normal operation, if JTAG is not used, this pin can be left unconnected (NC)
8	JTAG_TDI	-	For normal operation, if JTAG is not used, this pin can be left unconnected (NC)
9	JTAG_TRST	-	For normal operation, if JTAG is not used, this pin can be left unconnected (NC)
10	NC(ADC)	-	-
11	Reset	-	Module reset pin(Active low)
12	NC(GPIOA0)	-	Ground
13	NC(GPIOA1)	-	-
14	NC(GPIOA2)	-	-
15	Mode LED	-	-
16	NC(GPIOA4)	-	-
17	WIFI LED	-	-
18	NC(GPIOA7)	-	-
19	NC(GPIOA6)	-	-
20	GND	-	Ground
21	GND	-	Ground
22	VCC 3.3V	-	3.3V power supply
23	TXD	-	Serial data communication interface send
24	RTS	-	Serial flow control pin, ready to receive data / request the other party to send data (Active low)
25	CTS	-	Serial flow control pin , ready to receive data / request each other to send data (Active low, High level cannot send / Low level can send data)

26	RXD	-	Serial data communication interfece receive
27	NC(GPIOA7)	-	-
28	FUNC	-	-
29	NC(GPIOB3)	-	-
30	NC(GPIOA7)	-	-
31	NC(GPIOA7)	-	-
32	NC(GPIOA7)	-	-
33	NC(GPIOA7)	-	Ground
34	NC(GPIOA7)	-	-
35	NC(GPIOA7)	-	-

2. Electrical Specification

2.1 General specification

ITEMS	CONTENTS
Operating frequency	2.400 ~ 2.4835Ghz
WiFi standard	802.11b/g/n
Modulation	11b: DBPSK,DQPSK and CCK and DSSS
	11g: BPSK,QPSK16Qam,64QAM and OFDM
	11n: MCSO-15 OFD
Data rates	11b: 1,2,5.5 and 11Mbps
	11g:6,9,12,18,24,36,48, and 54Mbps
	11n:MCSO-15, up to 150Mbps
Host interface	UART
Demension	Typical (L x W): 21mm x 18mm
Operation Temperature	-20° C to +85° C
Storage Temperature	-55° C to +125° C
Operation Voltage	3.3V±0.2V

o

2.2 802.11g Mode

ITEMS	CONTENTS				
Specification	IEEE802.11g				
Mode	OFDM				
Channel	CH1 to CH13				
Data rate	6, 9, 12, 18, 24, 36, 48, 54Mbps				
Power level(calibrated)	Minimum	Typical	Maximum	Unit.	Note.
16dBm Target(For each antenna Port)	12	14	16	dBm	
Constellation error(EVM)@target power	Minimum	Typical	Maximum	Unit.	Note.
54Mbps		-30	-28	dB	
Frequency error	-25	0	+25	khZ	
Minimum input level sensitivity	Minimum	Typical	Maximum	Unit.	Note.
MCS7(PER ≤ 10 %)	-	-78	-	dBm	
Maximum input level(PER ≤ 10 %)	-	-10	-	dBm	

2.3 802.11g HT20 Mode

ITEMS	CONTENTS				
Specification	IEEE802.11n HT20@2.4Ghz				
Mode	OFDM				
Channel	CH1 to CH13				
Data rate	MCS0/1/2/3/4/5/6/7/8/9/10/11/12/13/14/15				
Power level(calibrated)	Minimum	Typical	Maximum	Unit.	Note.
16dBm Target(For each antenna Port)	12	14	16	dBm	
Constellation error(EVM)@target power MCS7	Minimum	Typical	Maximum	Unit.	Note.
		-30	-28	dB	
Frequency error	-25	0	+25	khZ	
Minimum input level sensitivity MCS7(PER ≤ 10 %)	Minimum	Typical	Maximum	Unit.	Note.
	-	-76	-	dBm	
Maximum input level(PER ≤ 10 %)	-	-10	-	dBm	

2.4 802.11g HT40 Mode

ITEMS	CONTENTS				
Specification	IEEE802.11n HT40@2.4Ghz				
Mode	OFDM				
Channel	CH1 to CH13				
Data rate	MCS0/1/2/3/4/5/6/7/8/9/10/11/12/13/14/15				
Power level(calibrated)	Minimum	Typical	Maximum	Unit.	Note.
16dBm Target(For each antenna Port)	12	14	16	dBm	
Constellation error(EVM)@target power MCS7	Minimum	Typical	Maximum	Unit.	Note.
		-30	-28	dB	
Frequency error	-25	0	+25	khZ	
Minimum input level sensitivity MCS7(PER ≤ 10 %)	Minimum	Typical	Maximum	Unit.	Note.
	-	-74	-	dBm	
Maximum input level(PER ≤ 10 %)	-	-10	-	dBm	

2.5 NVM specification

ITEMS	CONTENTS
Specification	NVM Flash
Space	160KByte
Operate write times	Total 10000 times

Note: NVM flash is used to store user configuration or firmware, do not use to store these often changed configuration or user data.

2.6 Power Consumption

State	Current(3.3V)	Description
Deep Sleep	5.5uA	Low Power Timer and GPIO Event Wake up
Deep Standby	25uA	Low Power Timer and GPIO Event Wake up
Associated Idle(DTIM=1)	3.3mA	Associated with AP but no traffic
Associated Idle(DTIM=2)	2.41mA	Associated with AP but no traffic
Associated Idle(DTIM=3)	1.98mA	Associated with AP but no traffic
Sleep	0.5mA	Associated with AP but no traffic
Run in active clock	25mA	CPU full run, UART available,WiFi is disable
11n RX mode	62mA	CPU full run, UART available,WiFi is in 11n RX
11n TX mode@13dBm	162mA	CPU full run, UART available,WiFi is in 11n RX
Peak current	240mA	CPU full run, UART available,WiFi is in 11n RX

3. Dimensions

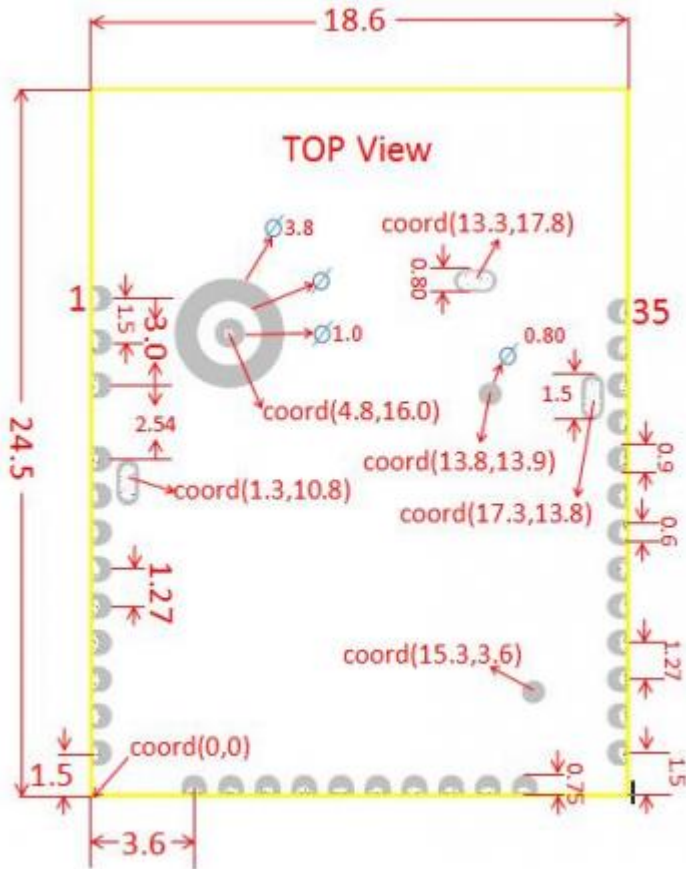

Type	Thickness (Height)
with CAN	3.15 (+/-) 0.15mm

4 Reference schematic

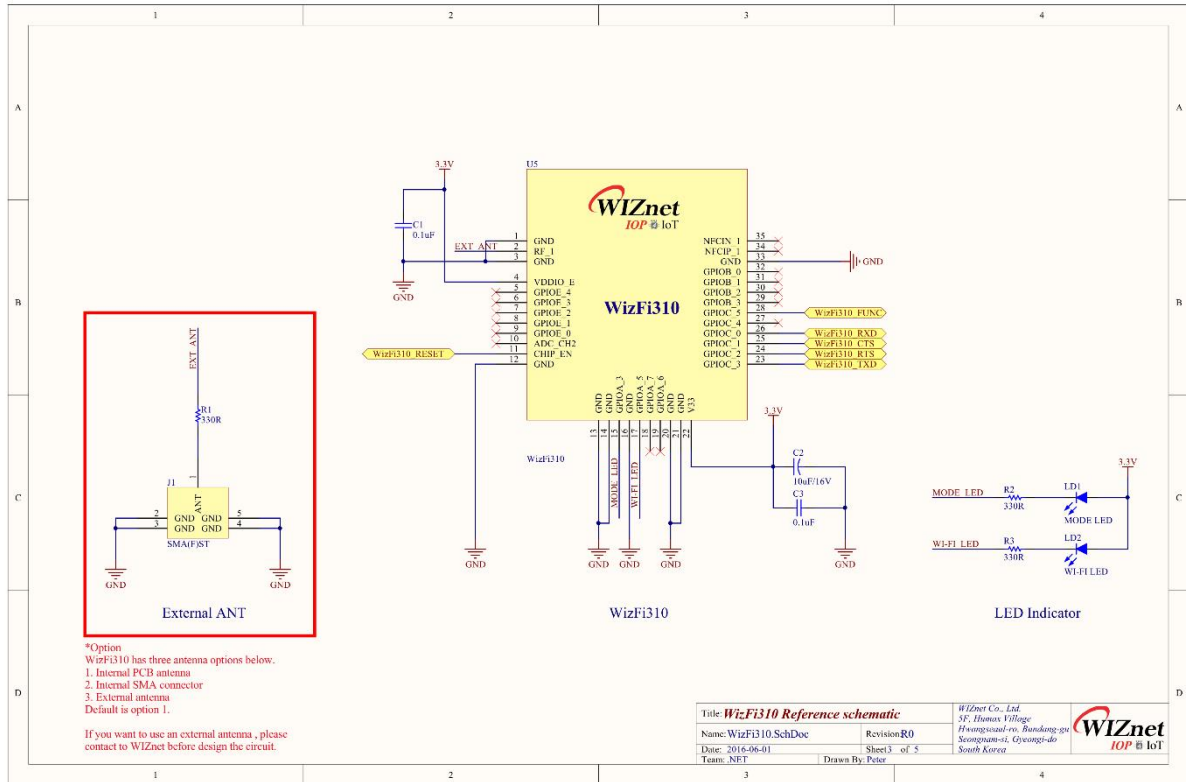

X-ON Electronics

Largest Supplier of Electrical and Electronic Components

Click to view similar products for [WiFi Development Tools - 802.11 category](#):

Click to view products by [Wiznet manufacturer](#):

Other Similar products are found below :

[YSAEWIFI-1](#) [SKY65981-11EK1](#) [QPF7221PCK-01](#) [SIMSA915C-Cloud-DKL](#) [SIMSA433C-Cloud-DKL](#) [ISM43903-R48-EVB-E](#)
[QPF4206BEVB01](#) [RN-G2SDK](#) [SKY85734-11EK1](#) [SKY85735-11EK1](#) [ENW49D01AZKF](#) [ESP-LAUNCHER](#) [MIKROE-2336](#)
[EVAL_PAN1760EMK](#) [3210](#) [EVAL_PAN1026EMK](#) [ATWINC1500-XPRO](#) [2471](#) [DM990001](#) [WRL-13711](#) [2999](#) [ATWILC3000-SHLD](#)
[DFR0321](#) [TEL0118](#) [3213](#) [DFR0489](#) [WRL-13804](#) [DEV-13907](#) [UP-3GHAT-A20-0001](#) [3405](#) [TEL0078](#) [2680](#) [2702](#) [2821](#) [3044](#) [3606](#) [3653](#)
[4000](#) [4172](#) [4178](#) [4201](#) [4285](#) [4289](#) [CS-ANAVI-25](#) [CS-ANAVI-26](#) [CS-ANAVI-23](#) [CS-ANAVI-24](#) [CS-ANAVI-28](#) [CS-ANAVI-29](#) [CS-ANAVI-30](#)