

RF Products and Services



The Wolfspeed RF Difference	2
Our Custom Solutions/GaN Foundry Services	3
Our Commercial Products	5
Our Product Solutions	15
Our Package Types	17
Where to Buy	20





The Wolfspeed RF Difference

Powering More. Consuming Less.™

For the past 30 years — first as a division of Cree and now as Wolfspeed — we have only focused on one thing: perfecting wide bandgap semiconductor technology. No one has more experience or expertise in the development and commercialization of Silicon Carbide (SiC) and Gallium Nitride (GaN). As the largest American producer of GaN-on-SiC RF wafer processing technology, Wolfspeed’s GaN HEMTs and MMICs enable enhanced innovation, performance and efficiency across a broad spectrum of RF and microwave applications for both the commercial and military sectors.

In 2018, we announced new LDMOS and GaN HEMT product offerings with Wolfspeed’s acquisition of Infineon’s RF power business. The expanded product portfolio accelerates the company’s progress in developing innovations for telecommunications and aerospace/defense applications.

WOLFSPEED’S GaN COMPONENTS enable next-generation electronics systems that are the best-in-class in efficiency and performance, including the lowest Failure-in-Time (FIT) rate in the industry.

WOLFSPEED’S LDMOS COMPONENTS portfolio, now with LD12, delivers on the promise of continued innovation for cellular applications such as improved 4G networks and the shift to 5G networks.

WOLFSPEED’S FOUNDRY SERVICES turn your designs into a faster, more reliable reality. As leaders in GaN-on-SiC MMIC technology, we have the design assistance, testing and support to realize your specifications from initial development to recurring production. Plus, as a volume supplier, we can do it with faster cycle times, higher first-pass design success and greater reliability than any competitor.

Each day the world’s electronics, industrial and communications sectors become more interconnected by evolving RF technologies. In offering the world’s most efficient and highest performing RF devices and Foundry Services, Wolfspeed is making any vision possible.



GaN RF LEADER

- Experience
- >206 Billion Field Hours
- >2 GW Shipped
- Innovation



LDMOS RF LEADER

- Asymmetric Doherty Transistors
- Integrated RF Power Amplifiers
- Fully Automated Production
- Advanced, Rugged and Stable Solutions



ACCELERATED TIME TO MARKET

Expert Engineers Focused on Supporting Advanced RF Solutions



TRUSTED FOUNDRY

World’s Largest Commercial Wide Bandgap Facility



BROAD PORTFOLIO

- Power Density
- Bandwidths
- Breakdown Voltage

Our Custom Solutions/GaN Foundry Services

Wolfspeed's GaN Foundry Services turn your designs into a faster, more reliable reality. As leaders in GaN-on-SiC MMIC technology, we have the design assistance, testing and support to realize your specifications from initial development to recurring production. Plus, we can do it with faster cycle times, higher first-pass design success and greater reliability than any competitor.*

*Based on publicly available competitor data and customer feedback.

Industry Leading

- World's largest dedicated, commercial, WBG-production-device facility
- 100-mm production line
- RF MMIC on-wafer probe/dice
- Microwave reliability labs
- RF application support

Process

	G28V3 MMIC	G28/40V4 MMIC	G50V3 MMIC
Gate Length	0.4 μm	0.25 μm	0.4 μm
Bias	28 V	28 V to 40 V	50 V
Breakdown	>120 V	>120 V	>150 V
Density	4.5 W/mm	6 W/mm	8 W/mm
Performance	DC-8 GHz	DC-18 GHz	DC-6 GHz

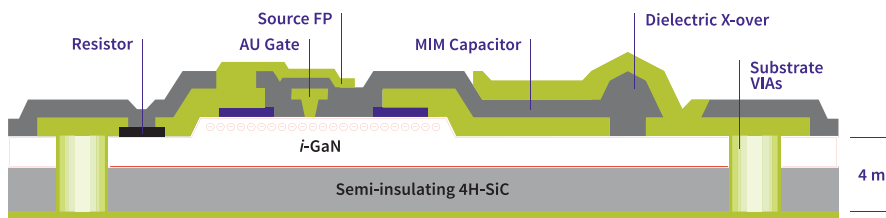

Features

- Dual-metal, 3 μm -thick interconnects
- Thin film and bulk resistors
- MIM capacitors >100 V
- Slot substrate VIAs
- Power FETs and Switch FETs



GaN RF Foundry Training Course

The Wolfspeed Foundry is now offering a course on how to design in the Wolfspeed FAB. This day-long course will offer participants the opportunity to:

- Interface with Cree on Foundry Services
- Learn how best to utilize our Process Design Kit
- Understand the proper steps in designing a MMIC or HEMT
- Follow proper procedure for submitting a design into the FAB

THIS TRAINING COURSE IS OFFERED QUARTERLY.



LOCATION

3028 E Cornwallis Rd
Durham, NC 27709



AGENDA

- Wolfspeed Foundry Overview
- Design Orientation
- Using Microwave Office or Advanced Design System Process Design Kit
- Design Guidelines and Limits
- Modeling

READY TO LEARN?

Visit <https://www.wolfspeed.com/foundry-training>

Our Commercial Products

Discrete Transistor Die

We offer families of GaN-on-SiC HEMTs for RF designers to customize the performance of their RF power amplifiers. Bare die offer maximum flexibility, making them ideal for designers wanting to make hybrids and modules.

Here is a list of discrete FETs operating at 28, 40 and 50 V with power levels ranging from 6 W to >300 W.

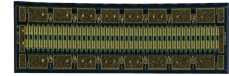
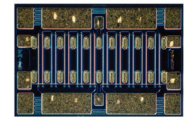

Part Number	Frequency (GHz)	Output Power (W)	Voltage (V)
CGHV1J006D	DC-18.0	6	28-40
CGH60008D	DC-6.0	8	28
CGH60015D	DC-6.0	15	28
CG2H80015D	DC-8.0	15	28
CGHV1J025D	DC-18.0	25	28-40
CGH60030D	DC-6.0	30	28
CG2H80030D	DC-8.0	30	28
CGHV60040D	DC-6.0	40	50
CGH60060D	DC-6.0	60	28
CG2H80060D	DC-8.0	60	28
CGHV1J070D	DC-18.0	70	40
CGHV60075D5	DC-6.0	75	50
CGH60120D	DC-6.0	120	28
CGHV60170D	DC-6.0	170	50
CGHV40320D	DC-6.0	320	50



MMIC Power Amplifier Die

In addition to offering FET die, we also offer high-performance, integrated circuits. These GaN-on-SiC MMIC power amplifiers target applications such as electronic warfare, communications, radar and test instrumentation.

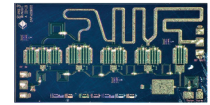
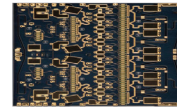

Part Number	Frequency (GHz)	Output Power (W)	Voltage (V)
CMPA0060002D	DC-6.0	2	28
CMPA0060025D	DC-6.0	25	28
CMPA2560025D	2.5-6.0	25	28
CMPA2735015D	2.7-3.5	15	50
CMPA2735030D	2.7-3.5	30	50
CMPA2735075D	2.7-3.5	75	28
CMPA5585025D	5.5-8.5	25	28
CMPA5585030D	5.5-8.5	25	28
CMPA601C025D	6.0-12.0	25	28
CMPA801B025D	8.0-11.0	25	28
CMPA1C1D060D	12.7-13.25	50	28
CMPA1D1E025D	13.75-14.5	25	28

Our Commercial Products

Internally Matched, Packaged Discrete Transistors

By moving some of the matching from the circuit board closer to the GaN-on-SiC HEMT bare die, the performance of the packaged transistor improves. As a result of the matching, the frequency of operation becomes application specific. The internal matching also makes the amplifier PCB design easier, especially when the packaged device is matched to 50-ohms on the input and output pins.

Here is a list of products matched for communications and radar applications ranging from L-band through X-band.



Part Number	Frequency (GHz)	Output Power (W)	Voltage (V)
CG2H30070F	0.5-3.0	80	28
CGHV14250	0.5-1.6	250	50
CGHV14500	0.5-1.8	530	50
CGHV14800	1.2-1.4	800	50
CGHV22100	1.8-2.2	100	50
CGHV22200	1.8-2.2	200	50
CGH21120F	1.8-2.3	120	28
CGH25120F	2.3-2.7	240	28
CGHV27100	2.5-2.7	100	50
CGHV27200	2.5-2.7	200	50
CGH31240	2.7-3.1	240	28
CGHV31500F	2.7-3.1	500	50
CGHV35150	2.9-3.5	150	50
CGHV35400F	2.9-3.5	400	50
CGHV35060MP	3.1-3.5	60	50
CGH35240	3.1-3.5	240	28
CGHV50200F	4.4-5.0	200	40
CGHV59070	5.2-5.9	70	50
CGHV59350	5.2-5.9	400	50
CGHV96050F1	7.9-8.4	50	40
CGHV96050F2	7.9-9.6	50	40
CGHV96100F2	7.9-9.6	100	40



Unmatched, Packaged Discrete Transistors

For designers wanting high-performance HEMTs with industry-leading reliability, we offer a line of packaged GaN-on-SiC HEMTs with no internal matching. These are packaged versions of the discrete HEMT die. Packages available include metal-ceramic and plastic overmold.

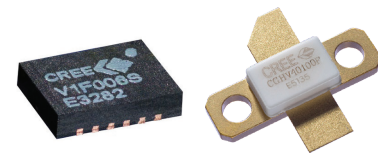

Part Number	Frequency (GHz)	Output Power (W)	Voltage (V)
CGH40006S	DC-6.0	6	28
CGH40006P	DC-6.0	6	28
CGHV1F006S	DC-18.0	6	20-40
CGH40010	DC-6.0	10	28
CG2H40010	DC-8.0	10	28
CGH27015	DC-6.0	15	28
CGH35015	DC-6.0	15	28
CGH55015	DC-6.0	15	28
CGHV27015S	DC-6.0	15	50
CGH40025	DC-6.0	25	28
CG2H40025	DC-8.0	25	28
CGHV1F025S	DC-15.0	25	20-40
CGH27030	DC-6.0	30	28
CGH27030S	DC-6.0	30	28
CGHV27030S	DC-6.0	30	50
CGH35030	DC-6.0	30	28
CGH55030	DC-6.0	30	28
CGHV40030	DC-6.0	30	50
CGH40035	DC-4.0	35	28
CGH40045	DC-4.0	45	28
CG2H40045	DC-4.0	45	28
CGHV40050	DC-4.0	50	50
CGH27060	DC-4.0	60	28
CGHV27060MP	DC-6.0	60	50
CGH40090PP	DC-3.0	90	28
CGHV40100	DC-3.0	100	50
CGH09120	DC-1.0	120	28
CGH40120	DC-3.0	120	28
CGH40180PP	DC-3.0	180	28
CGHV40180	DC-2.0	200	50

Our Commercial Products

Cellular Infrastructure RF Power Transistors (400 MHz to 3500 MHz)

We offer a broad portfolio of RF power transistors for use in the design of cellular base station amplifiers. Engineered to support all cellular standards and frequency bands, our products are enabling the next generation of 5G cellular solutions with state-of-the-art GaN-on-SiC and LDMOS transistors. Key features include high-power Doherty designs, ease of use with DPD systems, open-cavity and plastic package options and reference designs.

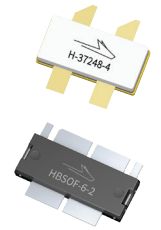

Part Number	Operating Frequency [MHz]	Matching	P _{1dB} typ [W]	Gain typ [dB]	Eff typ [%]	P _{out} avg [W]	Test Signal	Supply Voltage typ [V]	Technology	Package Type
420 MHz to 960 MHz										
PTFB072707FH	728-768	I/O	270	18.5	39.0	60	WCDMA	28	LDMOS	H-34288-4/2
PTFB090901EA	920-960	I/O	90	19.5	40.0	25	WCDMA	28	LDMOS	H-36265-2
PTFB090901FA	920-960	I/O	90	19.5	40.0	25	WCDMA	28	LDMOS	H-37265-2
PTFB091507FH	920-960	I/O	150	20.0	38.0	50	WCDMA	28	LDMOS	H-34288-4/2
PTFB091802FC	920-960	I/O	180	19.5	34.0	55	WCDMA	28	LDMOS	H-37248-4
PTRA094252FC	746-960	I	208	18.5	48.0	89	WCDMA	48	LDMOS	H-37248-4
PTVA082407NF	746-821	I	240	22.5	35.5	80	WCDMA	48	LDMOS	HBSOF-4-1
PTVA092407NF	869-960	I	240	22.0	39.0	80	WCDMA	48	LDMOS	HBSOF-4-1
PTFB092707FH	925-960	I/O	270	19.5	33.0	63	WCDMA	28	LDMOS	H-37288L-4/2
PTRA083818NF	733-805	I	275	18.0	56.0	81.3	WCDMA	48	LDMOS	HBSOF-6-2
PTRA082808NF	790-820	I/O	280	15.9	44.9	56.2	WCDMA	48	LDMOS	HBSOF-6-2
PTRA093302FC	746-768	I	330	17.3	51.6	79	WCDMA	50	LDMOS	H-37248-4
PTFB093608FV	920-960	I/O	2X180	20.0	34.0	112	WCDMA	28	LDMOS	H-37275G-6/2
PTVA084007NF	755-805	I/O	370	23.0	39.0	80	WCDMA	48	LDMOS	PG-HBSOF-4
PTRA093818NF	925-960	I/O	415	17.0	52.0	81.3	WCDMA	48	LDMOS	HBSOF-6-2
PTRA084808NF	734-821	I/O	480	18.0	55.0	87	WCDMA	48	LDMOS	PG-HBSOF-6
PTRA094808NF	859-960	I/O	480	17.5	52.5	87	WCDMA	48	LDMOS	HBSOF-6-2
PTRA097008NB	920-960	I/O	630	19.0	49.0	90	WCDMA	48	LDMOS	PG-HB2SOF-6
PTRA087008NB	755-805	I/O	650	18.5	52	107	WCDMA	48	LDMOS	PG-HB2SOF-6
1800 MHz TO 2000 MHz										
PXFC191507FC	1805-1990	I/O	150	20.5	31.0	32	WCDMA	28	LDMOS	H-37248G-4/2
PXAC182002FC	1805-1880	I/O	70+115	16.7	51.5	28.2	WCDMA	28	LDMOS	H-37248-4
PXFC192207FH	1805-1990	I/O	220	20.0	29.0	50	WCDMA	28	LDMOS	H-37288G-4/2
PTFB182503FL	1805-1880	I/O	240	19.0	28.0	50	WCDMA	30	LDMOS	H-34288-4/2
PTFB192503FL	1930-1990	I/O	240	19.0	28.0	50	WCDMA	30	LDMOS	H-34288-4/2
PXAC182908FV	1805-1880	I/O	240	15.0	51.0	70	WCDMA	28	LDMOS	H-37275G-6/2
PXAC192908FV	1930-1995	I/O	240	14.0	49.0	70	WCDMA	28	LDMOS	H-37275G-6/2
PTFB183404E	1805-1880	I/O	340	17.0	25.5	80	WCDMA	30	LDMOS	H-36275-8
PXAD184218FV	1805-1880	I/O	420 @P _{3dB}	16.0	51.5	60	WCDMA	28	LDMOS	H-37275G-6/2



Cellular Infrastructure RF Power Transistors (400 MHz to 3500 MHz) (Continued)

Part Number	Operating Frequency [MHz]	Matching	P _{1dB} typ [W]	Gain typ [dB]	Eff typ [%]	P _{OUT} avg [W]	Test Signal	Supply Voltage typ [V]	Technology	Package Type
2000 MHz to 2200 MHz										
PTFC210202FC	2110-2170	I/O	2X12	21.0	29.0	5	WCDMA	28	LDMOS	H-37248-4
PXAC210552FC	1805-2170	I/O	55	17.2	49.0	8	WCDMA	28	LDMOS	H-37248-4
GTVA220701FA	1805-2170	I	70 @P _{3DB}	22.0	27.0	6.3	LTE	50	GaN-on-SiC	H-37265J-2
PTAC210802FC	2110-2170	I/O	19+60	17.0	43.0	5	WCDMA	28	LDMOS	H-37248-4
PTFB210801FA	2110-2170	I/O	80	18.5	31.0	20	WCDMA	28	LDMOS	H-37265-2
PXAC200902FC	1805-2170	I/O	90	17.2	50.3	15	WCDMA	28	LDMOS	H-37248-4
PXAC201202FC	1800-2200	I/O	35+80	16.7	46.0	16	WCDMA	28	LDMOS	H-37248-4
PXAC201602FC	1880-2025	I/O	55+85	17.7	44.0	22	WCDMA	28	LDMOS	H-37248-4
PTFB201402FC	2010-2025	I/O	2X70	17.0	36.0	20	WCDMA	28	LDMOS	H-37248-4
PTFB211503FL	2110-2170	I/O	150	18.0	29.0	32	WCDMA	30	LDMOS	H-34288-4/2
PTFB212503FL	2110-2170	I/O	240	18.0	31.0	55	WCDMA	30	LDMOS	H-34288-4/2
PTFB213004F	2110-2170	I/O	300	18.0	26.5	60	WCDMA	30	LDMOS	H-37275-6/2
GTVA212701FA	2110-2200	I	300 @P _{3DB}	19	38	56.2	WCDMA	48	GaN-on-SiC	H-87265J-2
PTFB213208FV	2110-2170	I/O	2X160	17.0	33.0	50	WCDMA	28	LDMOS	H-37275G-6/2
PXAC213308FV	2110-2200	I/O	320	16.5	43.5	55	WCDMA	28	LDMOS	H-37275G-6/2
PXAC203302FV	1880-2025	I/O	330	16.5	49.0	56	WCDMA	28	LDMOS	H-37275-4
PXAD214218FV	2110-2170	I/O	430	16.0	49.0	56	WCDMA	28	LDMOS	H-37275G-6/2
2300 MHz TO 2400 MHz										
PTAC240502FC	2300-2400	I	17+33	14.3	44.0	10	WCDMA	28	LDMOS	H-37248-4
PXAC241002FC	2300-2400	I/O	40+60	15.5	45	15	WCDMA	28	LDMOS	H-37248C-4
PXAC241702FC	2300-2400	I/O	60+90	16.5	52.0	28	WCDMA	28	LDMOS	H-37248-4
PXAC243502FV	2300-2400	I/O	150+200	15.5	44.0	68	WCDMA	28	LDMOS	H-37275-4
2500 MHz TO 2700 MHz										
PTFC260202FC	2495-2690	I/O	2X12	20.0	30.0	5	WCDMA	28	LDMOS	H-37248-4
PTAC260302FC	2620-2690	I/O	12+17	15.5	45.0	5.5	WCDMA	28	LDMOS	H-37248H-4
PXAC260602FC	2620-2690	I/O	15+50	15.7	39.0	5	WCDMA	28	LDMOS	H-37248-4
PXAC261002FC	2496-2690	I/O	40+70	15.6	46.0	18	WCDMA	28	LDMOS	H-37248-4
PXAC261212FC	2496-2690	I/O	50+75	15.0	48.0	28	WCDMA	28	LDMOS	H-37248-4
PTFC261402FC	2620-2690	I/O	140	18.0	25.0	5	WCDMA	28	LDMOS	H-37248-4
GTVA261701FA	2620-2690	I	170 @P _{3DB}	17.0	43.0	40	WCDMA	50	GaN-on-SiC	H-37265J-2
GTVA261802FC	2620-2690	I	170 @P _{3DB}	16.8	43	50	WCDMA	48	GaN-on-SiC	H-37248C-4
PTFC262157FH	2620-2690	I/O	200	19.5	29.0	50	WCDMA	28	LDMOS	H-34288G-4/2
GTRA262802FC	2490-2690	I	250 @P _{3DB}	14	54	38	WCDMA	48	GaN-on-SiC	H-37248C-4
GTVA262701FA	2620-2690	I	270 @P _{3DB}	17	42	60	WCDMA	48	GaN-on-SiC	H-87265J-2
GTVA263202FC	2620-2690	I	340 @P _{3DB}	17	40	80	WCDMA	48	GaN-on-SiC	H-37248-4
GTRA263902FC	2495-2690	I	370 @P _{3DB}	13.8	54	56.2	WCDMA	48	GaN-on-SiC	H-37248C-4

Our Commercial Products

Cellular Infrastructure RF Power Transistors (400 MHz to 3500 MHz) (Continued)

Part Number	Operating Frequency [MHz]	Matching	P _{1dB} typ [W]	Gain typ [dB]	Eff typ [%]	P _{OUT} avg [W]	Test Signal	Supply Voltage typ [V]	Technology	Package Type
3400 MHZ TO 3600 MHZ										
GTRA362002FC	3400-3600	I	85 + 115 @P _{3DB}	13.5	42	29	WCDMA	48	GaN-on-SiC	H-37248C-4
GTRA362802FC	3400-3600	I	120 + 180 @P _{3DB}	13.5	45.5	44	WCDMA	48	GaN-on-SiC	H-37248C-4
GTRA364002FC	3400-3600	I	170 + 230 @P _{3DB}	13	40	50	WCDMA	48	GaN-on-SiC	H-37248C-4

General Purpose RF Transistors (900 MHz to 2200 MHz)

Our general-purpose transistors are unmatched for flexibility in use over a broad frequency range while providing high-power outputs. This products offer high gain, efficiency and linearity performance in a cost-effective overmold plastic package.



Product	Operating Frequency [MHz]	Matching	P _{1dB} typ [W]	Gain typ [dB]	Eff typ [%]	P _{OUT} avg [W]	Test Signal	Supply Voltage typ [V]	Technology	Package Type
PTFC270051M	900-2700	NO	7.3	20.0	60.0	–	CW @2170	28	LDMOS	SON-10
PTFC270101M	900-2700	NO	12	20.0	60.0	–	CW @2170	28	LDMOS	SON-10
PTVA120121M	500-1400	NO	12	21.0	65.0	15	CW	50	LDMOS	SON-10
PTVA120252MT	500-1400	NO	25	19.8	64.0	–	CW	50	LDMOS	SON-16

Integrated RF Power Amplifiers (700 MHz to 2200 MHz)

These two-stage integrated amplifiers are designed to provide high gain and on-chip matching for broadband performance. They are suitable for use in both driver and output stage amplifier applications.

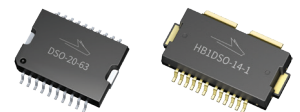

Product	Operating Frequency [MHz]	Matching	P _{1dB} typ [W]	Gain typ [dB]	Eff typ [%]	P _{OUT} avg [W]	Test Signal	Supply Voltage typ [V]	Technology	Package Type
PTGA090304MD	575-960	I/O	15+15	32	19	3.9	WCDMA	50	LDMOS	HB1DSO-14
PTMC210124MD	1800-2200	I/O	6+6	30.5	16.5	1.3	WCDMA	28	LDMOS	HB1DSO-14
PTMC210204MD	1805-2200	I/O	10+10	30.5	19.0	2.5	WCDMA	28	LDMOS	HB1DSO-14
PTMC210404MD	1805-2200	I/O	20+20	31.5	19.3	5	WCDMA	28	LDMOS	HB1DSO-14
PTNC210604MD	1805-2200	I/O	20+40	27	37	10	WCDMA	28	LDMOS	HB1DSO-14



UHF, L-Band & Broadcast RF Power Transistors (400 MHz to 1400 MHz)

For designers wanting high-performance HEMTs with industry-leading reliability, we offer a line of packaged GaN-on-SiC HEMTs with no internal matching. These are packaged versions of the discrete HEMT die. Packages available include metal-ceramic and plastic overmold.



Product	Operating Frequency [MHz]	Matching	P _{1dB} typ [W]	Gain typ [dB]	Eff typ [%]	P _{OUT} avg [W]	Test Signal	Supply Voltage typ [V]	Technology	Package Type
PTVA030121EA	390-450	NO	12	25.0	69.0	–	PULSED	50	LDMOS	H-36265-2
PTVA035002EV	390-450	NO	400	19.5	65.0	–	PULSED	50	LDMOS	H-36275-4
PTVA042502EC	470-806	I	250	19.0	25.5	55	DVB-T	50	LDMOS	H-36248-4
PTVA042502FC	470-806	I	250	19.0	25.5	55	DVB-T	50	LDMOS	H-37248-4
PTVA043502EC	470-860	I/O	350	18.0	29.5	70	DVB-T	50	LDMOS	H-36248-4
PTVA043502FC	470-860	I/O	350	18.0	29.5	70	DVB-T	50	LDMOS	H-37248-4
PTVA047002EV	470-806	I	700	17.5	29.0	130	DVB-T	50	LDMOS	H-36275-4
PTVA102001EA	1030/1090	I/O	200	18.0	57.0	–	PULSED	50	LDMOS	H-36265-2
GTVA104001FA	960-1215	I	410 @P _{3DB}	18.5	70.0	–	PULSED	50	GaN-on-SiC	H-37265J-2
PTVA104501EH	960-1215	I/O	450	17.0	57.0	–	PULSED	50	LDMOS	H-36288-2
GTVA107001FC	960-1215	I	750 @P _{3DB}	17.0	70.0	–	PULSED	50	GaN-on-SiC	H-37248-2
PTVA101K02EV	1030/1090	I	920	18.0	56.0	–	PULSED	50	LDMOS	H-36275-4
PTVA120251EA	500-1400	NO	30	16.0	56.0	–	PULSED	50	LDMOS	H-36265-2
PTVA120501EA	1200-1400	I	54	16.5	55.0	–	PULSED	50	LDMOS	H-36265-2
PTVA123501EC	1200-1400	I/O	375	17.0	55.0	–	PULSED	50	LDMOS	H-36248-2
PTVA123501FC	1200-1400	I/O	375	17.0	55.0	–	PULSED	50	LDMOS	H-37248-2
GTVA123501FA	1200-1400	I	370 @P _{3DB}	18.0	72.0	–	PULSED	50	GaN-on-SiC	H-37265J-2
GTVA126001FC	1200-1400	I	610 @P _{3DB}	18.0	70.0	–	PULSED	50	GaN-on-SiC	H-37248-2
PTVA127002EV	1200-1400	I/O	700	16.0	56.0	–	PULSED	50	LDMOS	H-36275-4

Our Commercial Products

Packaged MMIC Power Amplifiers

This line of GaN-on-SiC MMICs is matched to 50-ohms in/out for the smallest-sized power amplifiers for a given output power and application. They are matched for specific applications and frequency bands— from L-Band to Ku-Band.

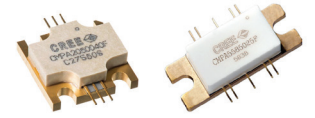

Part Number	Frequency (GHz)	Output Power (W)	Voltage (V)
CMPA0060002F	DC-6.0	2	28
CMPA0527005F	0.5-2.7	5	50
CMPA0060025F	DC-6.0	25	50
CMPA2560025F	2.5-6.0	25	28
CMPA5259025F	5.2-5.9	25	28
CMPA5259050F	5.2-5.9	50	28
CMPA2735075F	2.7-3.5	75	28
CMPA5585025F	5.5-8.5	25	28
CMPA5585030F	5.5-8.5	25	28



Don't waste time waiting.

Expanding 4G system capability and enabling the 5G revolution, Wolfspeed, A Cree Company, is already at the heart of today's 4G networks, and now has the broadest portfolio of LDMOS and GaN RF solutions.



400 W, 3.6 GHz
GaN HEMT

Our Product Solutions

RADAR Line-Up

Need kilowatts of power? We have devices for each stage of amplification - Pre-driver, driver and output stages. Here are some line-up suggestions for popular radar bands. If you do not see your frequency band from the line-ups below, then feel free to contact us for recommendations for radar solutions from UHF to X-Band.

L-BAND Solutions >1 kW, $V_{DD} = 50\text{ V}$

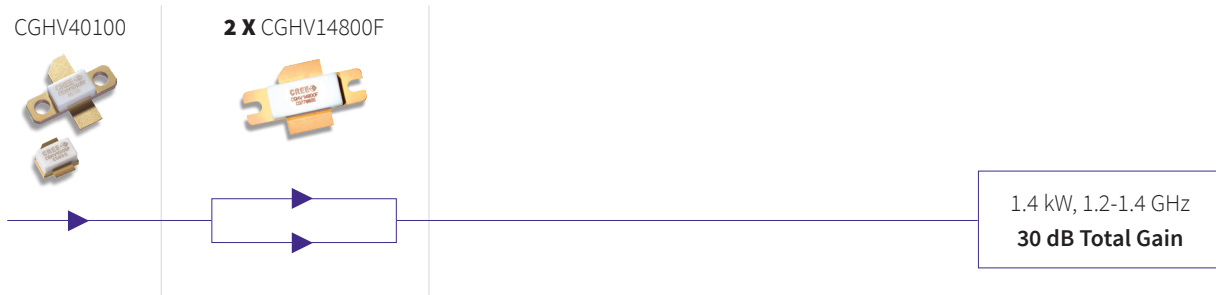

S-BAND Solutions >1 kW, $V_{DD} = 50\text{ V}$

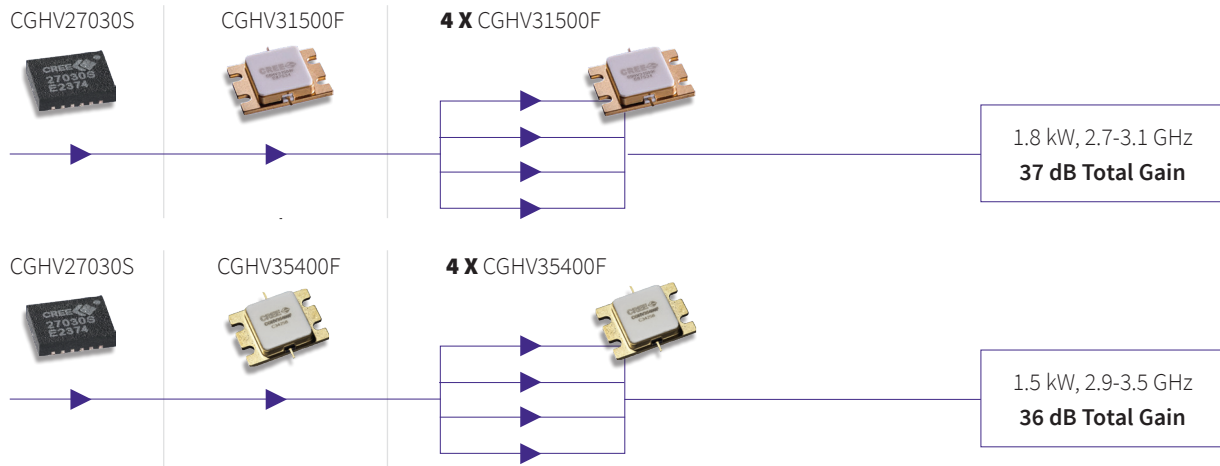

C-BAND Solutions at 1 kW, $V_{DD} = 50\text{ V}$

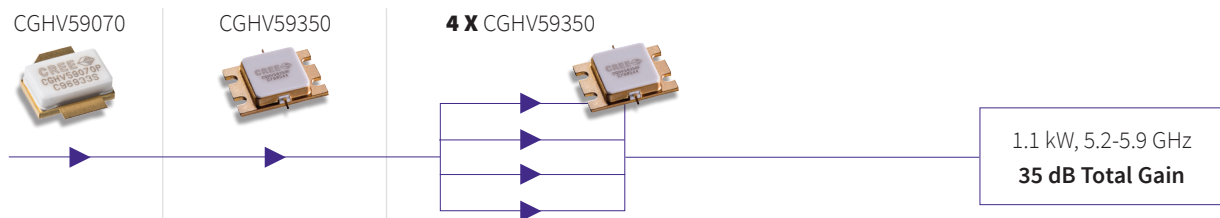



X-BAND Solutions >1 kW, $V_{DD} = 40\text{ V}$

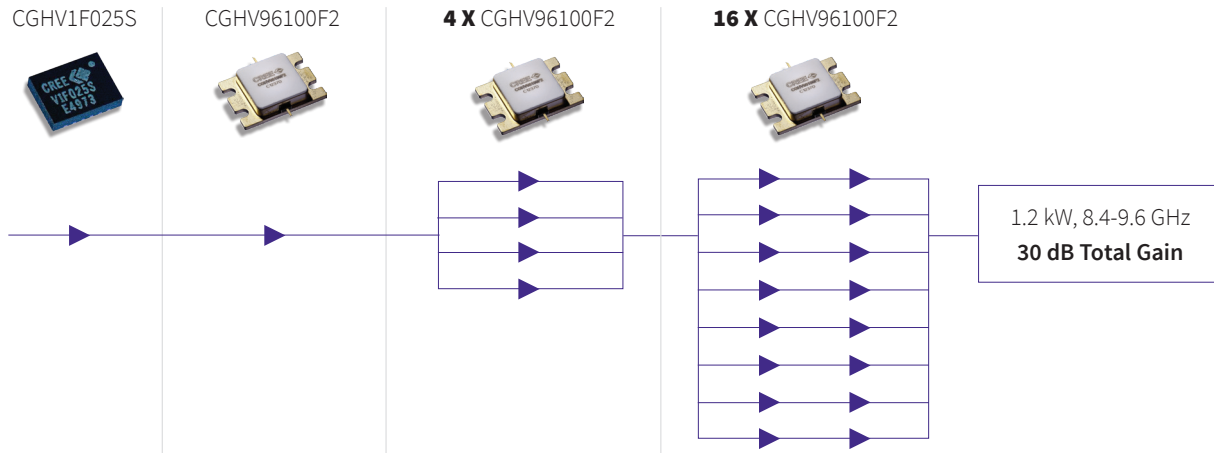

MILCOM Line-Up

In addition to recommendations for Radar power amplifier solutions, we offer line ups for several other power amplifier applications. One example is this solution for tactical radios with operating frequencies from 500-2700 MHz. This is a linear communications amplifier solution using unmatched discrete GaN HEMTs.

100 W, 0.5-2.7 GHz, $V_{DD} = 50\text{ V}$

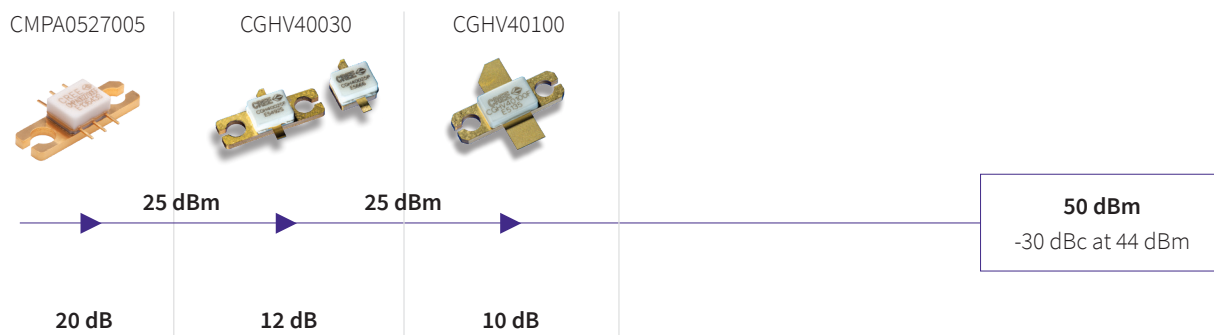

Our Package Types

Thermally-Enhanced, Open-Cavity Ceramic

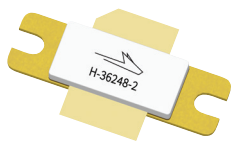

H-36248-2



H-37248-2

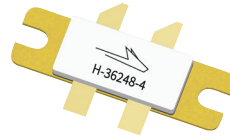

H-36248-4

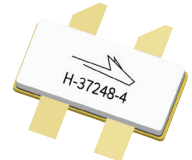

H-37248-4

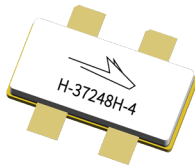

H-37248H-4

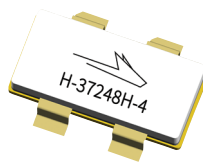

H-37248H-4
(formed leads)



H-37248G-4/2

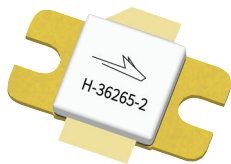

H-36265-2



H-37265-2 or
H-37265J-2



H-34288G-4/2 or
H-37288G-4/2 or
H-37288L-4/2

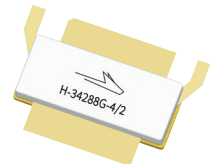

H-34288G-4/2 or
H-37288G-4/2
(formed leads)

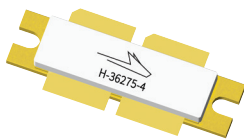

H-36275-4

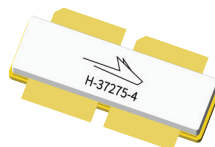

H-37275-4



H-37275-6/2



H-34275G-6/2 or
H-37275G-6/2

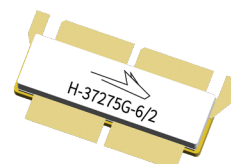

H-34275G-6/2 or
H-37275G-6/2
(formed leads)

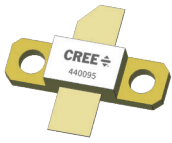

440095



440109



440117



440133



440161



440162



440166



440193



440196



440199



440201



440206



440208

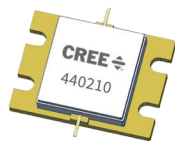

440210

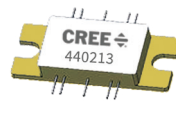

440213



440217



440223



440219



780019



CMPA0060025F



Our Package Types

Molded Plastic



DSO-20-63



SON-10



SON-16

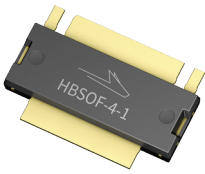

HBSOF-4-1



HB1SOF-4-1



HB1DSO-4-1



HB1DSO-14-1



HBSOF-6-2



HB1SOF-4-2



OMP-20L



440203



3X4 DFN



Where to Buy

Distributors - Global



Arrow Electronics, Inc.
www.arrow.com



Digi-Key Electronics
sales@digkey.com



Mouser Electronics
sales@mouser.com



Richardson RFPD
rfpdsales@richardsonrfd.com

Representatives - Americas



AceTec
sales@acetec.com
Southern California



Blackhart, LLC
triemma@blackhartllc.com
Colorado, Utah



Cain-Forlaw Co.
bryan.wolverton@cain-forlaw.com
Midwest, Texas, West Pennsylvania



Premiere Technical Sales
jbeard@premieretechs.com
Arizona, New Mexico



RepWave
fmasciotra@repwave.com
Canada



Sea-Port Technical Sales
tom@seaporttech.com
Pacific Northwest



Southeastern Sales RF
goliver@sesf.com
Florida, Georgia, Alabama



Spectrum Sales, Inc.
david@spectrumsales.com
New York City



Steward Technology
russ@stechrep.com
Northern California



WLM Components
billmorin@wlmcomponents.com
North East, Upstate New York

Representatives - EMEA



acal bfi
www.acalbfi.com
DE, IT, LU, NO, NL, ES, SE, GB, FR



Carpatec Complete
Component Solutions
hl@cccsolutions.eu
EE, FI, LV, LT



LHYTE
commercial@elhyte.fr
France, Belgium



Melcom
melcomsales@melcom.co.uk
UK, Ireland



MPLUS
info@m-plustec.com
Turkey



Nisko Projects
orit@nisko.co.il
Israel



ProSoft
info@prochip.ru
MD, TJ, TM, UZ, UA



TransTech
tte@transtech.cz
CZ, SK, PL, HU, RO, BG, UA

Representatives - China, Southeast Asia



APTECH
sales@apctechnologies.in
India



Telcom
sales@telcom.kr
South Korea



CELCOM
celcom@ms10.hinet.net
Taiwan



Sanetronic Company Limited
cree@sanetronic.com
China, Hong Kong



X-ON Electronics

Authorized Distributor

Click to view similar products for [RF Development Tools](#) category:

Click to view products by [Wolfspeed](#) / [Cree](#) manufacturer:

Other Similar products are found below :

[EV1HMC7911LP5](#) [EV-ADF70301-169BZ](#) [EV-ADF70301-433AZ](#) [EV-ADF70301-868BZ](#)
[EVAL01-HMC1042LC4](#) [EVAL01-HMC1065LP4](#) [EVAL01-HMC6981LS6](#) [EVAL01-](#)
[HMC985LP4KE](#) [EVAL01-HMC995LP5GE](#) [EVAL-ADF7020-1DBZ4](#) [EVAL-ADF7021-](#)
[NDBZ2](#) [F1953EVBI](#) [F2976EVBI-50OHM](#) [MDEV-315-HH-CP8-MS](#) [MDEV-315-HH-LR8-](#)
[MS](#) [MDEV-418-HH-CP8-MS](#) [MDEV-900-DT](#) [MDEV-900-RC](#) [MDEV-DEMO-RC-B](#)
[119696-HMC599ST89](#) [119926-HMC683LP6C](#) [117810-HMC460LC5](#) [118038-HMC476SC70](#)
[118040-HMC311SC70](#) [A1101R09C-EZ4A](#)