

CGH40025

25 W, RF Power GaN HEMT

Description

Cree's CGH40025 is an unmatched, gallium nitride (GaN) high electron mobility transistor (HEMT). The CGH40025, operating from a 28 volt rail, offers a general purpose, broadband solution to a variety of RF and microwave applications. GaN HEMTs offer high efficiency, high gain and wide bandwidth capabilities making the CGH40025 ideal for linear and compressed amplifier circuits. The transistor is available in a screw-down, flange package and solder-down, pill packages.

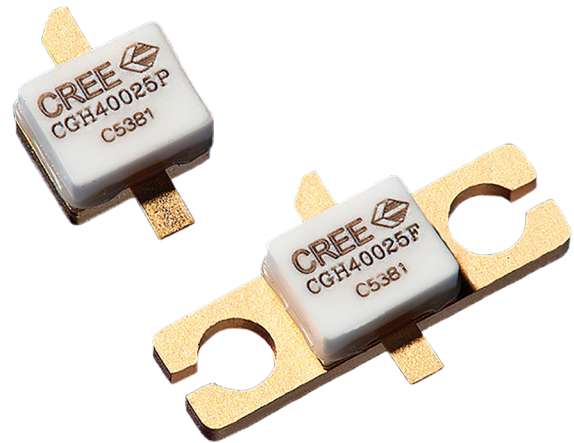

Package Types: 440196 & 440166
PN: CGH40025P & CGH40025F

Features

- Up to 6 GHz Operation
- 15 dB Small Signal Gain at 2.0 GHz
- 13 dB Small Signal Gain at 4.0 GHz
- 30 W typical P_{SAT}
- 62% Efficiency at P_{SAT}
- 28 V Operation

Applications

- 2-Way Private Radio
- Broadband Amplifiers
- Cellular Infrastructure
- Test Instrumentation
- Class A, AB, Linear amplifiers suitable for OFDM, W-CDMA, EDGE, CDMA waveforms

Absolute Maximum Ratings (not simultaneous) at 25 °C Case Temperature

Parameter	Symbol	Rating	Units	Conditions
Drain-Source Voltage	V_{DSS}	120	Volts	25 °C
Gate-to-Source Voltage	V_{GS}	-10, +2	Volts	25 °C
Storage Temperature	T_{STG}	-65, +150	°C	
Operating Junction Temperature	T_J	225	°C	
Maximum Forward Gate Current	I_{GMAX}	7.0	mA	25 °C
Maximum Drain Current ¹	I_{DMAX}	3	A	25 °C
Soldering Temperature ²	T_S	245	°C	
Screw Torque	τ	40	in-oz	
Thermal Resistance, Junction to Case ³	$R_{\theta JC}$	4.8	°C/W	85 °C
Case Operating Temperature ^{3,4}	T_C	-40, +150	°C	

Notes:

¹ Current limit for long term, reliable operation

² Refer to the Application Note on soldering at wolfspeed.com/RF/Document-Library

³ Measured for the CGH40025F at $P_{DISS} = 28$ W

⁴ See also, the Power Dissipation De-rating Curve on Page 6

Electrical Characteristics (TC = 25 °C)

Characteristics	Symbol	Min.	Typ.	Max.	Units	Conditions
DC Characteristics¹						
Gate Threshold Voltage	$V_{GS(th)}$	-3.8	-3.0	-2.3	V_{DC}	$V_{DS} = 10$ V, $I_D = 7.2$ mA
Gate Quiescent Voltage	$V_{GS(Q)}$	-	-2.7	-	V_{DC}	$V_{DS} = 28$ V, $I_D = 250$ mA
Saturated Drain Current	I_{DS}	5.8	7.0	-	A	$V_{DS} = 6.0$ V, $V_{GS} = 2.0$ V
Drain-Source Breakdown Voltage	V_{BR}	84	-	-	V_{DC}	$V_{GS} = -8$ V, $I_D = 7.2$ mA
RF Characteristics² ($T_C = 25$ °C, $F_0 = 3.7$ GHz unless otherwise noted)						
Small Signal Gain	G_{SS}	12	13	-	dB	$V_{DD} = 28$ V, $I_{DQ} = 250$ mA
Power Output ³	P_{SAT}	20	30	-	W	$V_{DD} = 28$ V, $I_{DQ} = 250$ mA
Drain Efficiency ⁴	η	55	62	-	%	$V_{DD} = 28$ V, $I_{DQ} = 250$ mA, P_{SAT}
Output Mismatch Stress	VSWR	-	-	10 : 1	Ψ	No damage at all phase angles, $V_{DD} = 28$ V, $I_{DQ} = 250$ mA, $P_{OUT} = 25$ W CW
Dynamic Characteristics						
Input Capacitance	C_{GS}	-	9.0	-	pF	$V_{DS} = 28$ V, $V_{GS} = -8$ V, $f = 1$ MHz
Output Capacitance	C_{DS}	-	2.6	-	pF	$V_{DS} = 28$ V, $V_{GS} = -8$ V, $f = 1$ MHz
Feedback Capacitance	C_{GD}	-	0.4	-	pF	$V_{DS} = 28$ V, $V_{GS} = -8$ V, $f = 1$ MHz

Notes:

¹ Measured on wafer prior to packaging

² Measured in CGH40025-AMP

³ P_{SAT} is defined as $I_G = 0.72$ mA

⁴ Drain Efficiency = P_{OUT} / P_{DC}



Typical Performance

Small Signal Gain and Return Loss vs Frequency of the CGH40025F in the CGH40025-AMP

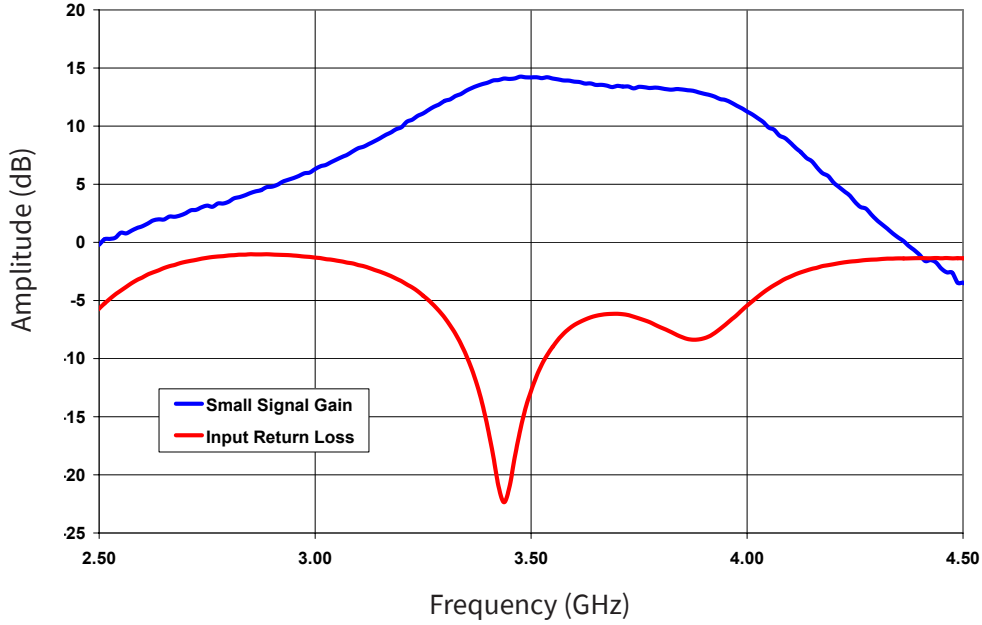

P_{SAT} , Gain, and Drain Efficiency vs Frequency of the CGH40025F in the CGH40025-AMP

$V_{DD} = 28\text{ V}, I_{DQ} = 250\text{ mA}$

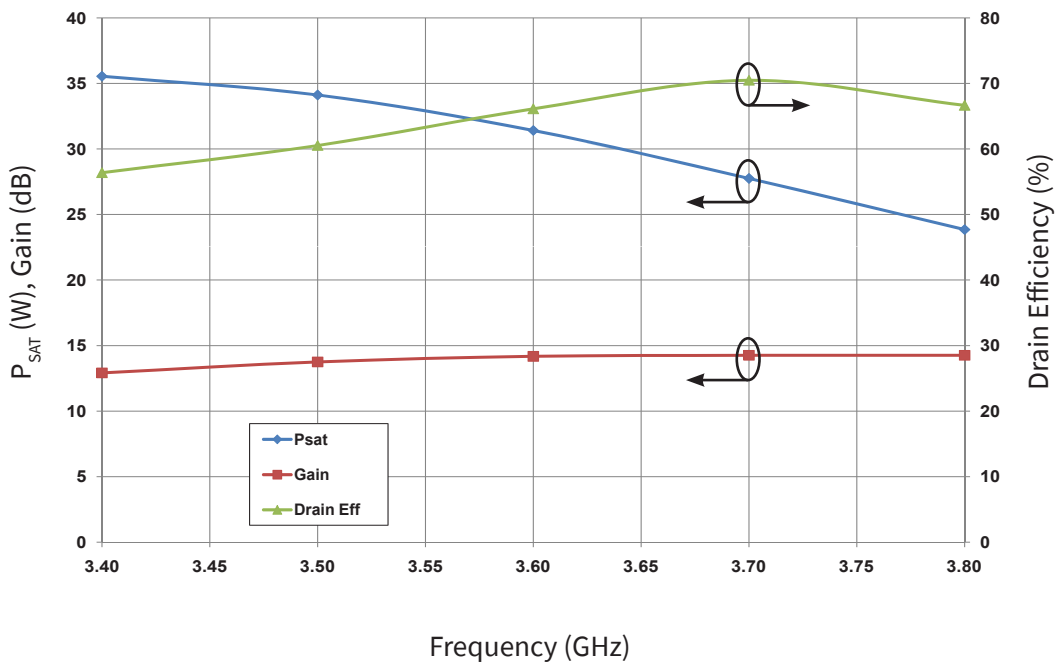



Typical Performance

Swept CW Data of CGH40025 vs. Output Power with Source and Load Impedances Optimized for P_{SAT} Power in CGH40025-AMP
 $V_{DD} = 28\text{ V}$, $I_{DQ} = 250\text{ mA}$, Freq = 3.7 GHz

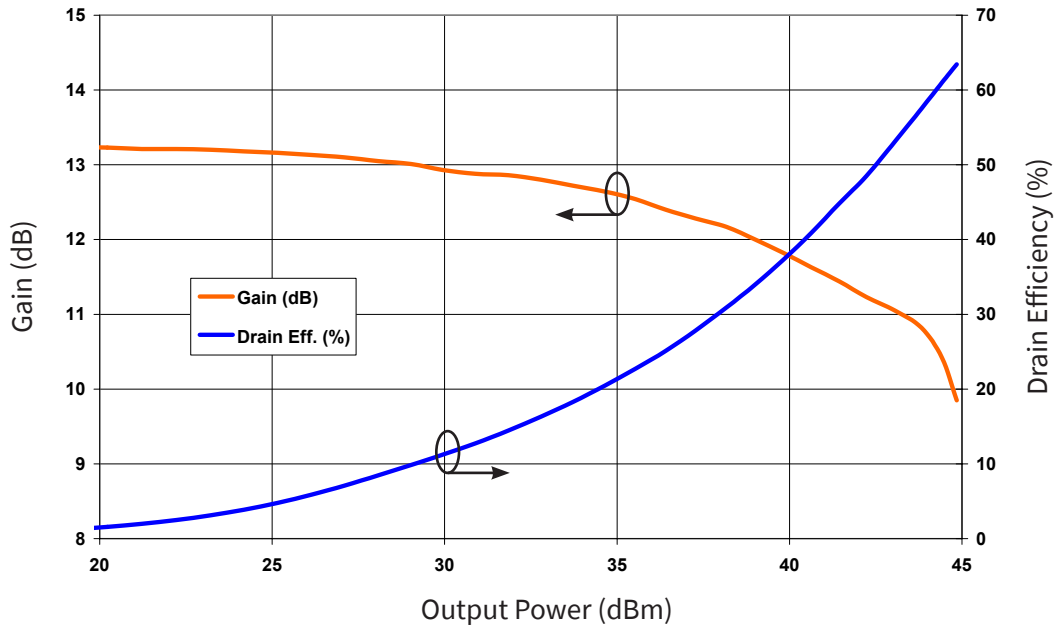

Maximum Available Gain and K Factor of the CGH40025
 $V_{DD} = 28\text{ V}$, $I_{DQ} = 250\text{ mA}$

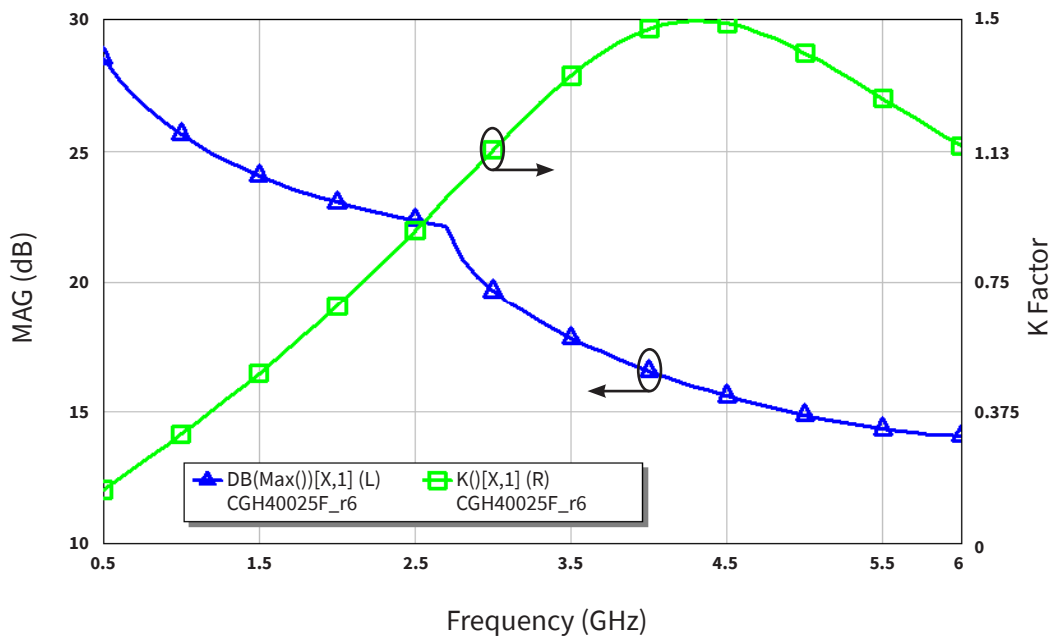



Typical Noise Performance

Simulated Minimum Noise Figure and Noise Resistance vs Frequency of the CGH40025F
 VDD = 28 V, IDQ = 250 mA

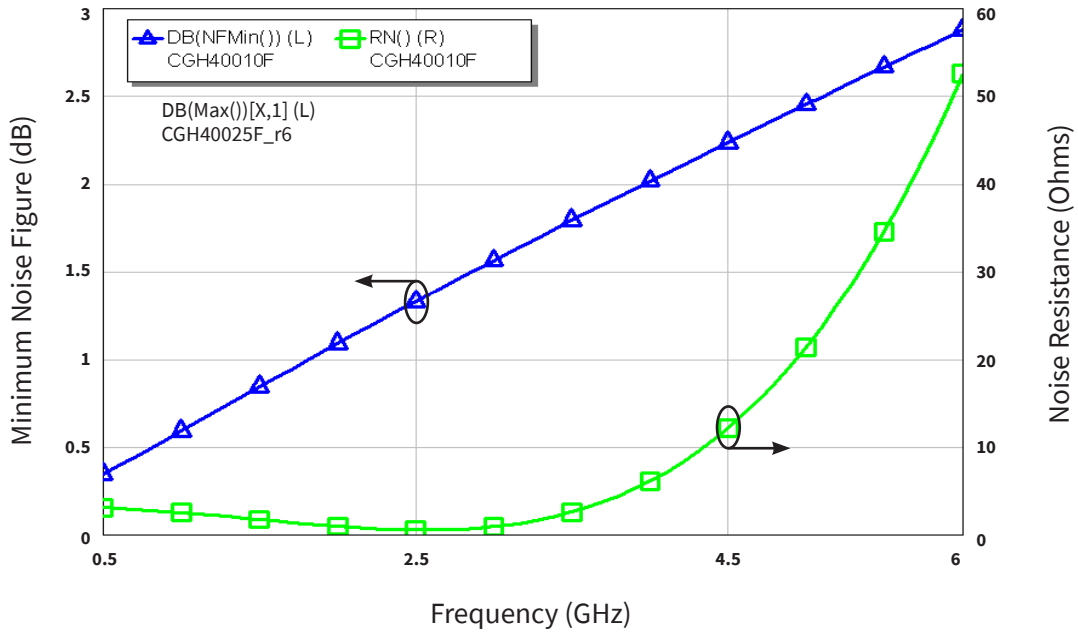

Electrostatic Discharge (ESD) Classifications

Parameter	Symbol	Class	Test Methodology
Human Body Model	HBM	1A > 250 V	JEDEC JESD22 A114-D
Charge Device Model	CDM	1 < 200 V	JEDEC JESD22 C101-C



Source and Load Impedances

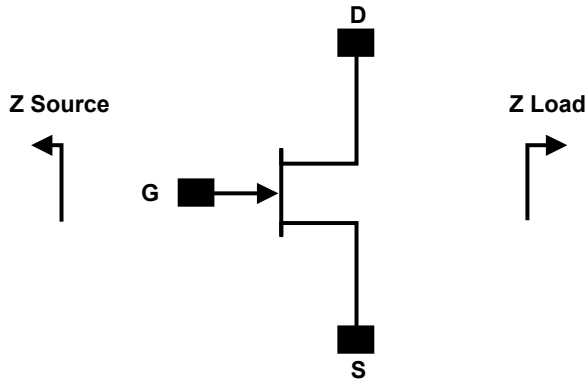

Frequency	Z Source	Z Lead
500	7.75 + j15.5	20 + j5.2
1000	3.11 + j5.72	17 + j6.66
1500	2.86 + j1.63	16.8 + j3.2
2500	2.4 - j3.52	8.02 + j4.32
3500	1.31 - j7.3	5.85 - j0.51

Note 1. $V_{DD} = 28V$, $I_{DD} = 250mA$ in the 440166 package

Note 2. Optimized for power, gain, P_{SAT} and PAE

Note 3. When using this device at low frequency, series resistors should be used to maintain amplifier stability

CGH40025 Power Dissipation De-rating Curve

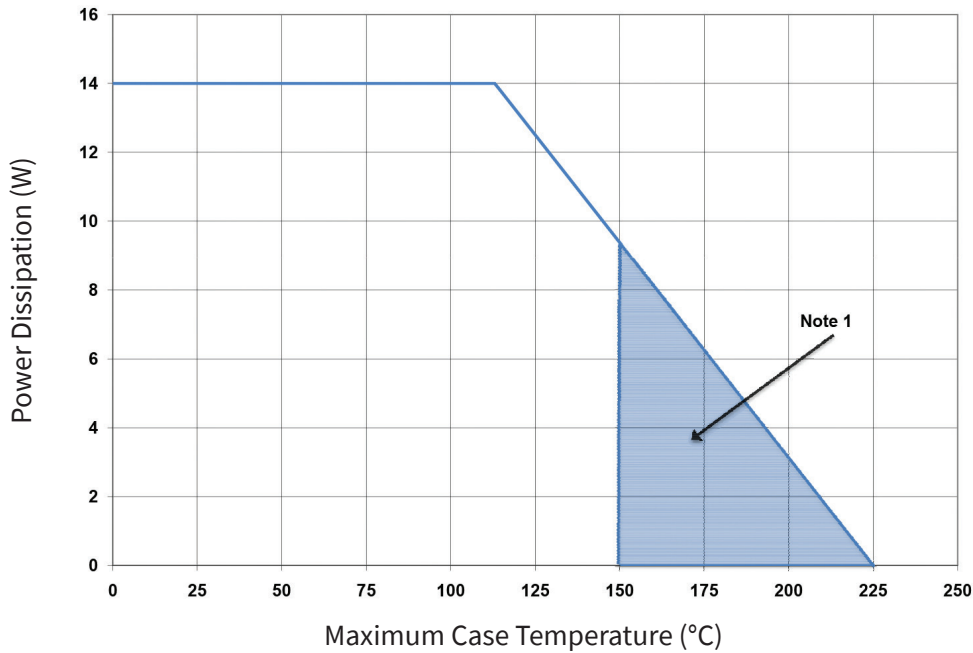

Note 1. Area exceeds Maximum Case Operating Temperature (See Page 2).



CGH40025-AMP Demonstration Amplifier Circuit Schematic

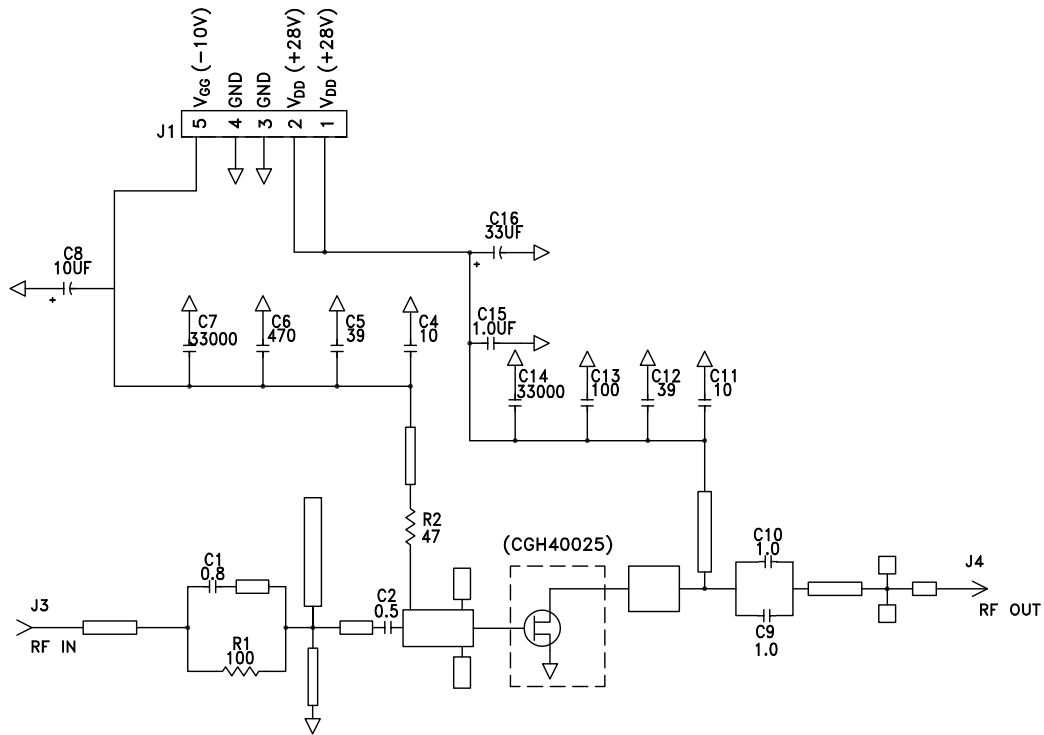

CGH40025-AMP Demonstration Amplifier Circuit Outline

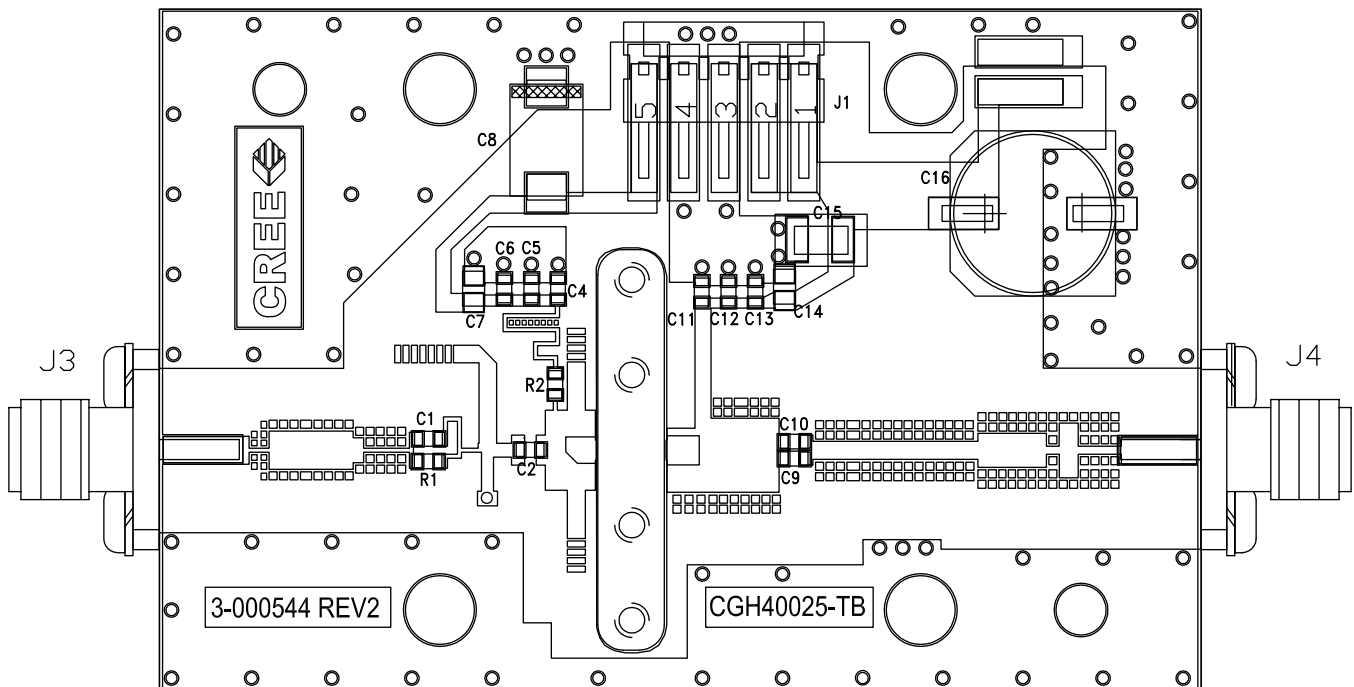

CGH40025-AMP Demonstration Amplifier Circuit Bill of Materials

Designator	Description	Qty
R2	RES, 1/16W, 0603, 1%, 47 OHMS	1
R1	RES, 1/16W, 0603, 1%, 100 OHMS	1
C6	CAP, 470PF, 5%, 100V, 0603	1
C16	CAP, 33 UF, 20%, G CASE	1
C15	CAP, 1.0UF, 100V, 10%, X7R, 1210	1
C8	CAP, 10UF 16V TANTALUM	1
C13	CAP, 100.0pF, +/-5%, 0603	1
C1	CAP, 0.8pF, +/-0.1pF, 0603	1
C2	CAP, 0.5pF, +/-0.05pF, 0603	1
C9, C10	CAP, 1.0pF, +/-0.1pF, 0603	2
C4, C11	CAP, 10.0pF, +/-5%, 0603	2
C5, C12	CAP, 39pF, +/-5%, 0603	2
C7, C14	CAP, 33000PF, 0805, 100V, X7R	2
J3, J4	CONN SMA STR PANEL JACK RECP	2
J1	HEADER RT>PLZ .1CEN LK 5POS	1
-	PCB, RO4350B, Er = 3.48, h = 20 mil	1
-	CGH40025F or CGH40025P	1

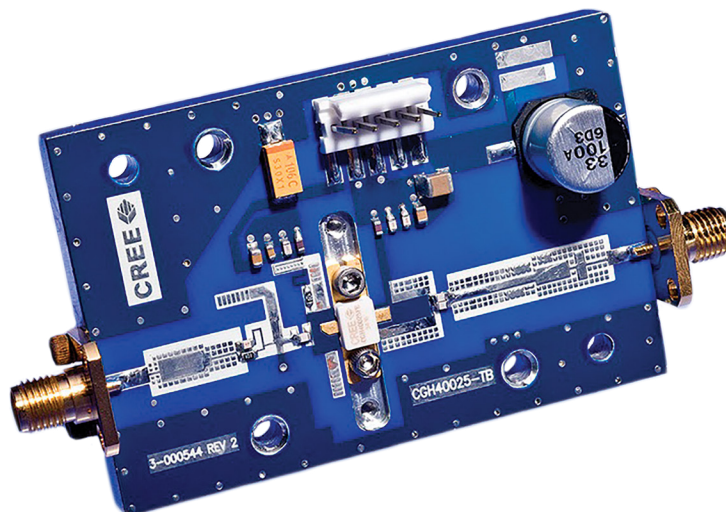
CGH40025F-AMP Demonstration Amplifier Circuit



Typical Package S-Parameters for CGH40025
 (Small Signal, $V_{DS} = 28\text{ V}$, $I_{DQ} = 100\text{ mA}$, angle in degrees)

Frequency	Mag S11	Ang S11	Mag S21	Ang S21	Mag S12	Ang S12	Mag S22	Ang S22
500 MHz	0.902	-151.72	11.80	92.09	0.025	6.22	0.393	-140.34
600 MHz	0.901	-157.13	9.89	87.31	0.025	2.28	0.402	-143.54
700 MHz	0.900	-161.20	8.49	83.18	0.025	-0.99	0.412	-145.64
800 MHz	0.900	-164.41	7.42	79.49	0.025	-3.82	0.424	-147.11
900 MHz	0.901	-167.04	6.58	76.10	0.024	-6.33	0.436	-148.22
1.0 GHz	0.902	-169.26	5.89	72.93	0.024	-8.60	0.449	-149.12
1.1 GHz	0.903	-171.19	5.33	69.93	0.024	-10.69	0.462	-149.91
1.2 GHz	0.904	-172.89	4.86	67.07	0.023	-12.61	0.476	-150.65
1.3 GHz	0.905	-174.43	4.45	64.33	0.023	-14.39	0.489	-151.38
1.4 GHz	0.906	-175.84	4.10	61.68	0.022	-16.06	0.503	-152.12
1.5 GHz	0.907	-177.14	3.80	59.12	0.022	-17.61	0.517	-152.87
1.6 GHz	0.909	-178.36	3.54	56.64	0.022	-19.05	0.531	-153.65
1.7 GHz	0.910	-179.52	3.30	54.22	0.021	-20.38	0.545	-154.46
1.8 GHz	0.912	-179.38	3.09	51.87	0.021	-21.62	0.558	-155.29
1.9 GHz	0.913	-178.33	2.90	49.58	0.020	-22.75	0.571	-156.15
2.0 GHz	0.914	-177.30	2.73	47.34	0.020	-23.78	0.584	-157.04
2.1 GHz	0.916	-176.31	2.58	45.15	0.019	-24.70	0.596	-157.95
2.2 GHz	0.917	-175.34	2.44	43.02	0.019	-25.52	0.608	-158.88
2.3 GHz	0.918	-174.39	2.31	40.92	0.018	-26.22	0.620	-159.82
2.4 GHz	0.920	-173.46	2.19	38.88	0.018	-26.82	0.631	-160.78
2.5 GHz	0.921	-172.54	2.09	36.87	0.017	-27.29	0.642	-161.76
2.6 GHz	0.922	-171.63	1.99	34.91	0.016	-27.64	0.652	-162.74
2.7 GHz	0.923	-170.73	1.90	32.98	0.016	-27.85	0.662	-163.73
2.8 GHz	0.925	-169.84	1.82	31.09	0.015	-27.92	0.672	-164.73
2.9 GHz	0.926	-168.95	1.74	29.24	0.015	-27.85	0.681	-165.73
3.0 GHz	0.927	-168.07	1.67	27.41	0.014	-27.61	0.690	-166.74
3.2 GHz	0.929	-166.30	1.54	23.86	0.013	-26.63	0.706	-168.76
3.4 GHz	0.931	-164.54	1.42	20.42	0.013	-24.89	0.721	-170.79
3.6 GHz	0.932	-162.78	1.33	17.08	0.012	-22.30	0.735	-172.82
3.8 GHz	0.934	-161.00	1.24	13.84	0.011	-18.80	0.748	-174.85
4.0 GHz	0.935	-159.21	1.16	10.67	0.011	-14.40	0.759	-176.88
4.2 GHz	0.936	-157.39	1.10	7.58	0.010	-9.18	0.769	-178.90
4.4 GHz	0.937	-155.55	1.04	4.55	0.010	-3.38	0.778	-179.07
4.6 GHz	0.938	-153.67	0.98	1.57	0.010	2.65	0.787	-177.04
4.8 GHz	0.939	-151.77	0.94	-1.36	0.011	8.52	0.794	-175.00
5.0 GHz	0.939	-149.82	0.89	-4.25	0.011	13.87	0.801	-172.96
5.2 GHz	0.939	-147.82	0.86	-7.11	0.012	18.48	0.807	-170.90
5.4 GHz	0.939	-145.78	0.82	-9.95	0.013	22.25	0.812	-168.83
5.6 GHz	0.940	-143.68	0.79	-12.78	0.014	25.17	0.817	-166.74
5.8 GHz	0.939	-141.53	0.77	-15.59	0.016	27.32	0.821	-164.62
6.0 GHz	0.939	-139.31	0.74	-18.41	0.017	28.77	0.825	-162.48

To download the s-parameters in s2p format, go to the [CGH40025 Product page](#) and click on the documentation tab.

Typical Package S-Parameters for CGH40025 (Small Signal, $V_{DS} = 28\text{ V}$, $I_{DQ} = 250\text{ mA}$, angle in degrees)

Frequency	Mag S11	Ang S11	Mag S21	Ang S21	Mag S12	Ang S12	Mag S22	Ang S22
500 MHz	0.917	-157.22	12.62	91.45	0.018	7.56	0.458	-158.97
600 MHz	0.916	-161.92	10.57	87.33	0.018	4.70	0.465	-160.93
700 MHz	0.916	-165.46	9.07	83.78	0.018	2.41	0.472	-162.19
800 MHz	0.916	-168.28	7.94	80.58	0.018	0.51	0.478	-163.04
900 MHz	0.916	-170.61	7.05	77.64	0.017	-1.12	0.485	-163.64
1.0 GHz	0.916	-172.60	6.33	74.88	0.017	-2.55	0.493	-164.09
1.1 GHz	0.917	-174.33	5.74	72.25	0.017	-3.82	0.500	-164.45
1.2 GHz	0.917	-175.88	5.24	69.73	0.017	-4.94	0.508	-164.77
1.3 GHz	0.918	-177.28	4.82	67.30	0.017	-5.95	0.516	-165.06
1.4 GHz	0.918	-178.57	4.46	64.94	0.017	-6.84	0.525	-165.36
1.5 GHz	0.919	-179.78	4.14	62.65	0.016	-7.63	0.533	-165.67
1.6 GHz	0.919	-179.09	3.87	60.41	0.016	-8.31	0.542	-165.99
1.7 GHz	0.920	-178.01	3.62	58.22	0.016	-8.90	0.550	-166.35
1.8 GHz	0.921	-176.98	3.40	56.07	0.016	-9.39	0.559	-166.73
1.9 GHz	0.921	-175.99	3.21	53.97	0.015	-9.77	0.568	-167.14
2.0 GHz	0.922	-175.03	3.03	51.90	0.015	-10.06	0.577	-167.59
2.1 GHz	0.923	-174.09	2.87	49.87	0.015	-10.24	0.585	-168.07
2.2 GHz	0.924	-173.17	2.73	47.87	0.014	-10.31	0.594	-168.57
2.3 GHz	0.924	-172.27	2.60	45.91	0.014	-10.27	0.602	-169.11
2.4 GHz	0.925	-171.39	2.47	43.97	0.014	-10.12	0.610	-169.67
2.5 GHz	0.926	-170.51	2.36	42.07	0.014	-9.85	0.619	-170.26
2.6 GHz	0.926	-169.65	2.26	40.19	0.013	-9.46	0.626	-170.88
2.7 GHz	0.927	-168.79	2.16	38.34	0.013	-8.95	0.634	-171.52
2.8 GHz	0.928	-167.93	2.08	36.52	0.013	-8.31	0.642	-172.17
2.9 GHz	0.928	-167.08	1.99	34.72	0.013	-7.54	0.649	-172.85
3.0 GHz	0.929	-166.24	1.92	32.94	0.013	-6.65	0.656	-173.55
3.2 GHz	0.930	-164.54	1.78	29.45	0.012	-4.49	0.670	-175.00
3.4 GHz	0.931	-162.85	1.66	26.05	0.012	-1.85	0.683	-176.50
3.6 GHz	0.932	-161.14	1.55	22.72	0.012	1.19	0.695	-178.06
3.8 GHz	0.933	-159.42	1.46	19.46	0.012	4.55	0.706	-179.66
4.0 GHz	0.933	-157.68	1.38	16.27	0.012	8.08	0.716	-178.70
4.2 GHz	0.934	-155.91	1.31	13.12	0.012	11.64	0.726	-177.02
4.4 GHz	0.934	-154.11	1.24	10.03	0.013	15.08	0.735	-175.30
4.6 GHz	0.935	-152.28	1.18	6.97	0.013	18.26	0.743	-173.56
4.8 GHz	0.935	-150.41	1.13	3.95	0.014	21.09	0.750	-171.78
5.0 GHz	0.935	-148.49	1.08	0.96	0.015	23.50	0.756	-169.97
5.2 GHz	0.935	-146.53	1.04	-2.00	0.016	25.48	0.762	-168.12
5.4 GHz	0.935	-144.52	1.00	-4.96	0.017	27.02	0.768	-166.24
5.6 GHz	0.935	-142.45	0.97	-7.90	0.018	28.12	0.773	-164.32
5.8 GHz	0.934	-140.31	0.94	-10.84	0.020	28.83	0.777	-162.36
6.0 GHz	0.934	-138.12	0.91	-13.79	0.021	29.18	0.781	-160.36

To download the s-parameters in s2p format, go to the [CGH40025 Product page](#) and click on the documentation tab.

Typical Package S-Parameters for CGH40025
 (Small Signal, $V_{DS} = 28\text{ V}$, $I_{DQ} = 400\text{ mA}$, angle in degrees)

Frequency	Mag S11	Ang S11	Mag S21	Ang S21	Mag S12	Ang S12	Mag S22	Ang S22
500 MHz	0.924	-159.12	12.64	91.13	0.015	8.27	0.485	-163.72
600 MHz	0.923	-163.56	10.58	87.23	0.015	5.84	0.491	-165.34
700 MHz	0.923	-166.92	9.08	83.86	0.015	3.96	0.497	-166.41
800 MHz	0.923	-169.60	7.95	80.83	0.015	2.43	0.502	-167.13
900 MHz	0.923	-171.82	7.06	78.03	0.015	1.16	0.508	-167.65
1.0 GHz	0.923	-173.72	6.34	75.40	0.015	0.08	0.514	-168.05
1.1 GHz	0.923	-175.39	5.75	72.89	0.015	-0.84	0.520	-168.36
1.2 GHz	0.924	-176.88	5.26	70.48	0.015	-1.62	0.526	-168.63
1.3 GHz	0.924	-178.24	4.84	68.15	0.015	-2.29	0.533	-168.88
1.4 GHz	0.924	-179.50	4.48	65.89	0.015	-2.85	0.539	-169.13
1.5 GHz	0.925	179.33	4.17	63.68	0.014	-3.31	0.546	-169.38
1.6 GHz	0.925	178.22	3.89	61.52	0.014	-3.67	0.553	-169.65
1.7 GHz	0.926	177.17	3.65	59.41	0.014	-3.93	0.560	-169.94
1.8 GHz	0.926	176.16	3.43	57.34	0.014	-4.09	0.568	-170.26
1.9 GHz	0.927	175.18	3.24	55.30	0.014	-4.16	0.575	-170.60
2.0 GHz	0.927	174.24	3.07	53.29	0.014	-4.13	0.582	-170.97
2.1 GHz	0.928	173.32	2.91	51.32	0.013	-4.00	0.589	-171.36
2.2 GHz	0.928	172.41	2.76	49.38	0.013	-3.76	0.597	-171.79
2.3 GHz	0.929	171.53	2.63	47.46	0.013	-3.43	0.604	-172.24
2.4 GHz	0.929	170.65	2.51	45.57	0.013	-2.99	0.611	-172.71
2.5 GHz	0.929	169.79	2.40	43.71	0.013	-2.44	0.618	-173.22
2.6 GHz	0.930	168.93	2.30	41.87	0.013	-1.79	0.625	-173.75
2.7 GHz	0.930	168.08	2.20	40.05	0.012	-1.04	0.632	-174.30
2.8 GHz	0.931	167.24	2.12	38.26	0.012	-0.18	0.638	-174.87
2.9 GHz	0.931	166.40	2.04	36.48	0.012	0.77	0.645	-175.47
3.0 GHz	0.932	165.56	1.96	34.73	0.012	1.82	0.651	-176.08
3.2 GHz	0.932	163.88	1.82	31.28	0.012	4.18	0.663	-177.37
3.4 GHz	0.933	162.20	1.70	27.91	0.012	6.83	0.675	-178.72
3.6 GHz	0.934	160.51	1.60	24.60	0.012	9.69	0.686	179.86
3.8 GHz	0.934	158.80	1.51	21.35	0.012	12.64	0.696	178.39
4.0 GHz	0.935	157.07	1.42	18.16	0.013	15.58	0.706	176.88
4.2 GHz	0.935	155.32	1.35	15.01	0.013	18.40	0.715	175.31
4.4 GHz	0.935	153.53	1.29	11.91	0.014	21.01	0.723	173.70
4.6 GHz	0.935	151.70	1.23	8.84	0.014	23.33	0.730	172.05
4.8 GHz	0.935	149.84	1.17	5.80	0.015	25.32	0.737	170.36
5.0 GHz	0.935	147.93	1.13	2.79	0.016	26.96	0.743	168.63
5.2 GHz	0.935	145.98	1.09	-0.20	0.017	28.24	0.749	166.86
5.4 GHz	0.935	143.97	1.05	-3.19	0.018	29.16	0.754	165.05
5.6 GHz	0.934	141.91	1.01	-6.16	0.020	29.75	0.759	163.20
5.8 GHz	0.934	139.78	0.98	-9.14	0.021	30.02	0.763	161.30
6.0 GHz	0.933	137.58	0.96	-12.12	0.023	29.99	0.767	159.35

To download the s-parameters in s2p format, go to the [CGH40025 Product page](#) and click on the documentation tab.

Product Dimensions CGH40025F (Package Type — 440166)

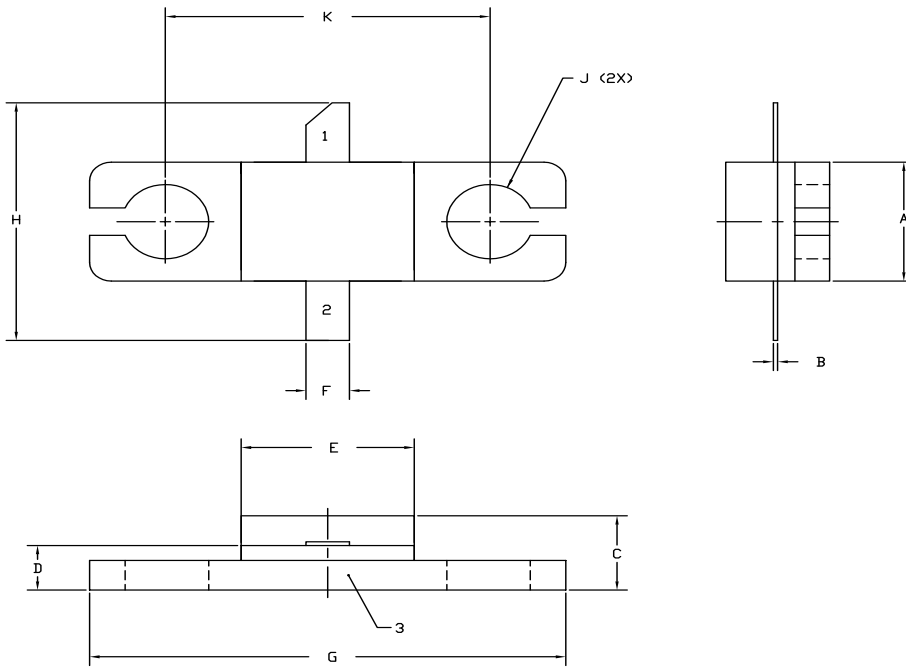

NOTES:

1. DIMENSIONING AND TOLERANCING PER ANSI Y14.5M, 1982.
2. CONTROLLING DIMENSION: INCH.
3. ADHESIVE FROM LID MAY EXTEND A MAXIMUM OF 0.020" BEYOND EDGE OF LID.
4. LID MAY BE MISALIGNED TO THE BODY OF THE PACKAGE BY A MAXIMUM OF 0.008" IN ANY DIRECTION.
5. ALL PLATED SURFACES ARE NI/AU

DIM	INCHES		MILLIMETERS	
	MIN	MAX	MIN	MAX
A	0.155	0.165	3.94	4.19
B	0.004	0.006	0.10	0.15
C	0.115	0.135	2.92	3.43
D	0.057	0.067	1.45	1.70
E	0.195	0.205	4.95	5.21
F	0.045	0.055	1.14	1.40
G	0.545	0.555	13.84	14.09
H	0.280	0.360	7.11	9.14
J	∅ .100		2.54	
K	0.375		9.53	

- PIN 1. GATE
 PIN 2. DRAIN
 PIN 3. SOURCE

Product Dimensions CGH400265P (Package Type — 440196)

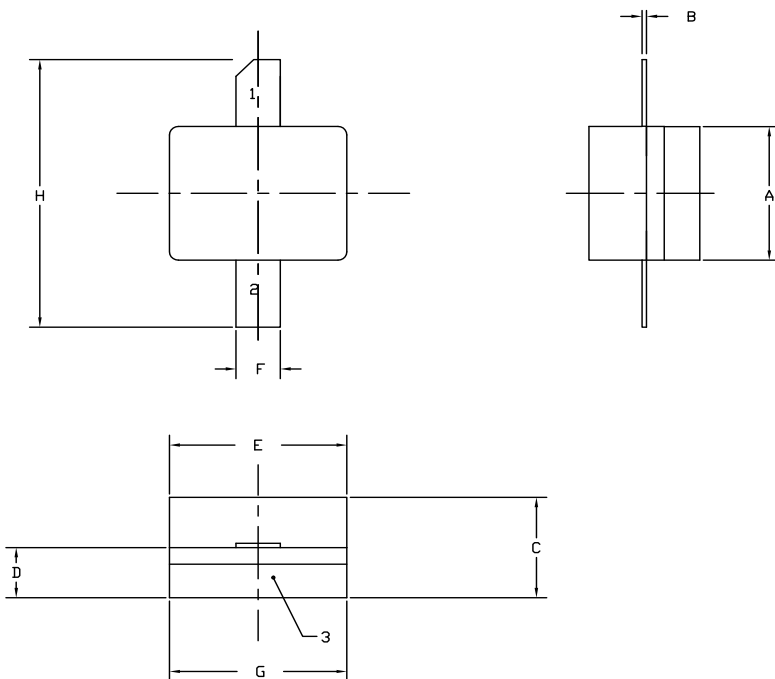

NOTES:



1. DIMENSIONING AND TOLERANCING PER ANSI Y14.5M, 1982.
2. CONTROLLING DIMENSION: INCH.
3. ADHESIVE FROM LID MAY EXTEND A MAXIMUM OF 0.020" BEYOND EDGE OF LID.
4. LID MAY BE MISALIGNED TO THE BODY OF THE PACKAGE BY A MAXIMUM OF 0.008" IN ANY DIRECTION.
5. ALL PLATED SURFACES ARE NI/AU

DIM	INCHES		MILLIMETERS	
	MIN	MAX	MIN	MAX
A	0.155	0.165	3.94	4.19
B	0.003	0.006	0.10	0.15
C	0.115	0.135	2.92	3.17
D	0.057	0.067	1.45	1.70
E	0.195	0.205	4.95	5.21
F	0.045	0.055	1.14	1.40
G	0.195	0.205	4.95	5.21
H	0.280	0.360	7.11	9.14

- PIN 1. GATE
 PIN 2. DRAIN
 PIN 3. SOURCE

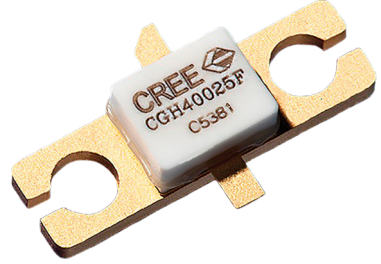

Product Ordering Information

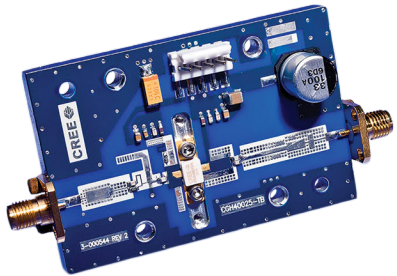
Order Number	Description	Unit of Measure	Image
CGH40025F	GaN HEMT	Each	 A photograph of a GaN HEMT device (CGH40025F) mounted on a gold-colored metal carrier. The device is a small, rectangular, light-colored component with the CREE logo and part number printed on it.
CGH40025P	GaN HEMT	Each	 A photograph of a GaN HEMT device (CGH40025P) showing its top surface. It is a small, rectangular, light-colored component with the CREE logo and part number printed on it.
CGH40025F-AMP	Test board with GaN HEMT installed	Each	 A photograph of a blue printed circuit board (PCB) test board. It features various electronic components, including a GaN HEMT device, capacitors, and connectors. The CREE logo and part number are visible on the board.



For more information, please contact:

4600 Silicon Drive
Durham, North Carolina, USA 27703
www.wolfspeed.com/rf

Sales Contact
RFSales@cree.com

Notes

Disclaimer

Specifications are subject to change without notice. “Typical” parameters are the average values expected by Cree in large quantities and are provided for information purposes only. Cree products are not warranted or authorized for use as critical components in medical, life-saving, or life-sustaining applications, or other applications where a failure would reasonably be expected to cause severe personal injury or death. No responsibility is assumed by Cree for any infringement of patents or other rights of third parties which may result from use of the information contained herein. No license is granted by implication or otherwise under any patent or patent rights of Cree.

X-ON Electronics

Largest Supplier of Electrical and Electronic Components

Click to view similar products for [RF Development Tools](#) category:

Click to view products by [Wolfspeed](#) manufacturer:

Other Similar products are found below :

[MAAM-011117](#) [MAAP-015036-DIEEV2](#) [EV1HMC1113LP5](#) [EV1HMC6146BLC5A](#) [EV1HMC637ALP5](#) [EVAL-ADG919EBZ](#) [ADL5363-EVALZ](#) [LMV228SDEVAL](#) [SKYA21001-EVB](#) [SMP1331-085-EVB](#) [EV1HMC618ALP3](#) [EVAL01-HMC1041LC4](#) [MAAL-011111-000SMB](#)
[MAAM-009633-001SMB](#) [107712-HMC369LP3](#) [107780-HMC322ALP4](#) [SP000416870](#) [EV1HMC470ALP3](#) [EV1HMC520ALC4](#)
[EV1HMC244AG16](#) [MAX2614EVKIT#](#) [124694-HMC742ALP5](#) [SC20ASATEA-8GB-STD](#) [MAX2837EVKIT+](#) [MAX2612EVKIT#](#)
[MAX2692EVKIT#](#) [SKY12343-364LF-EVB](#) [108703-HMC452QS16G](#) [EV1HMC863ALC4](#) [EV1HMC427ALP3E](#) [119197-HMC658LP2](#)
[EV1HMC647ALP6](#) [ADL5725-EVALZ](#) [106815-HMC441LM1](#) [EV1HMC1018ALP4](#) [UXN14M9PE](#) [MAX2016EVKIT](#) [EV1HMC939ALP4](#)
[MAX2410EVKIT](#) [MAX2204EVKIT+](#) [EV1HMC8073LP3D](#) [SIMSA868-DKL](#) [SIMSA868C-DKL](#) [SKY65806-636EK1](#) [SKY68020-11EK1](#)
[SKY67159-396EK1](#) [SKY66181-11-EK1](#) [SKY65804-696EK1](#) [SKY13396-397LF-EVB](#) [SKY13380-350LF-EVB](#)