

CGHV14500F

500 W, DC - 1800 MHz, GaN HEMT for L-Band Radar Systems

Description

Cree's CGHV14500 is a gallium nitride (GaN) high electron mobility transistor (HEMT) designed specifically with high efficiency, high gain and wide bandwidth capabilities, which makes the CGHV14500 ideal for DC - 1.8 GHz L-Band radar amplifier applications. The transistor could be utilized for band specific applications ranging from 800 through 1600 MHz. The package options are ceramic/metal flange and pill package.

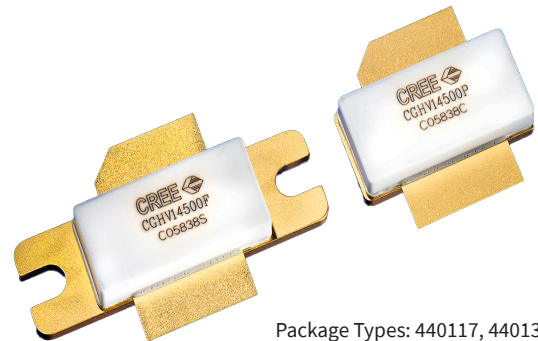

Package Types: 440117, 440133
PNs: CGHV14500F, CGHV14500P

Typical Performance Over 1.2 - 1.4 GHz (TC = 25 °C) of Demonstration Amplifier

Parameter	1.2 GHz	1.25 GHz	1.3 GHz	1.35 GHz	1.4 GHz	Units
Output Power	545	540	530	530	530	W
Gain	16.4	16.3	16.2	16.2	16.2	dB
Drain Efficiency	69	69	68	66	65	%

Note: Measured in the CGHV14500-AMP amplifier circuit, under 500 μs pulse width, 10% duty cycle, PIN = 41 dBm.

Features

- Reference design amplifier 1.2 - 1.4 GHz Operation
- FET tuning range UHF through 1800 MHz
- 500 W Typical Output Power
- 16 dB Power Gain
- 68% Typical Drain Efficiency
- <0.3 dB Pulsed Amplitude Droop
- Internally pre-matched on input, unmatched output

 Large Signal Models Available for ADS and MWO

RoHS
COMPLIANT

Absolute Maximum Ratings (not simultaneous)

Parameter	Symbol	Rating	Units	Conditions
Drain-Source Voltage	V_{DSS}	150	Volts	25 °C
Gate-to-Source Voltage	V_{GS}	-10, +2	Volts	25 °C
Storage Temperature	T_{STG}	-65, +150	°C	
Operating Junction Temperature	T_J	225	°C	
Maximum Forward Gate Current	I_{GMAX}	84	mA	25 °C
Maximum Drain Current ¹	I_{DMAX}	36	A	25 °C
Soldering Temperature ²	T_s	245	°C	
Screw Torque	τ	40	in-oz	
Pulsed Thermal Resistance, Junction to Case ³	$R_{\theta JC}$	0.28	°C/W	$P_{DISS} = 334 \text{ W}, 500 \mu\text{sec}, 10\%, 85 \text{ °C}$
Pulsed Thermal Resistance, Junction to Case ⁴	$R_{\theta JC}$	0.31	°C/W	$P_{DISS} = 334 \text{ W}, 500 \mu\text{sec}, 10\%, 85 \text{ °C}$
Case Operating Temperature ⁵	T_c	-40, +130	°C	$P_{DISS} = 334 \text{ W}, 500 \mu\text{sec}, 10\%$

Notes:

¹ Current limit for long term, reliable operation² Refer to the Application Note on soldering at www.wolfspeed.com/rf/document-library³ Measured for the CGHV14500P⁴ Measured for the CGHV14500F⁵ See also, the Power Dissipation De-rating Curve on Page 5**Electrical Characteristics ($T_c = 25 \text{ °C}$)**

Characteristics	Symbol	Min.	Typ.	Max.	Units	Conditions
DC Characteristics¹						
Gate Threshold Voltage	$V_{GS(th)}$	-3.8	-3.0	-2.3	V_{DC}	$V_{DS} = 10 \text{ V}, I_D = 83.6 \text{ mA}$
Gate Quiescent Voltage	$V_{GS(Q)}$	-	-2.7	-	V_{DC}	$V_{DS} = 50 \text{ V}, I_D = 500 \text{ mA}$
Saturated Drain Current ²	I_{DS}	54.3	77.7	-	A	$V_{DS} = 6.0 \text{ V}, V_{GS} = 2.0 \text{ V}$
Drain-Source Breakdown Voltage	V_{BR}	125	-	-	V_{DC}	$V_{GS} = -8 \text{ V}, I_D = 83.6 \text{ mA}$
RF Characteristics³ ($T_c = 25 \text{ °C}, F_0 = 1.4 \text{ GHz}$ unless otherwise noted)						
Output Power	P_{OUT}	400	500	-	W	$V_{DD} = 50 \text{ V}, I_{DQ} = 500 \text{ mA}, P_{IN} = 41 \text{ dBm}$
Drain Efficiency	D_E	60	68	-	%	$V_{DD} = 50 \text{ V}, I_{DQ} = 500 \text{ mA}, P_{IN} = 41 \text{ dBm}$
Power Gain	G_p	15.25	16.2	-	dB	$V_{DD} = 50 \text{ V}, I_{DQ} = 500 \text{ mA}, P_{IN} = 41 \text{ dBm}$
Pulsed Amplitude Droop	D	-	-0.3	-	dB	$V_{DD} = 50 \text{ V}, I_{DQ} = 500 \text{ mA}$
Output Mismatch Stress	VSWR	-	5 : 1	-	Y	No damage at all phase angles, $V_{DD} = 50 \text{ V}, I_{DQ} = 500 \text{ mA}, P_{IN} = 41 \text{ dBm}$ Pulsed
Dynamic Characteristics						
Input Capacitance	C_{GS}	-	295	-	pF	$V_{DS} = 50 \text{ V}, V_{gs} = -8 \text{ V}, f = 1 \text{ MHz}$
Output Capacitance	C_{DS}	-	27	-	pF	$V_{DS} = 50 \text{ V}, V_{gs} = -8 \text{ V}, f = 1 \text{ MHz}$
Feedback Capacitance	C_{GD}	-	2.7	-	pF	$V_{DS} = 50 \text{ V}, V_{gs} = -8 \text{ V}, f = 1 \text{ MHz}$

Notes:

¹ Measured on wafer prior to packaging² Scaled from PCM data³ Measured in CGHV14500-AMP. Pulsed Width = 500 μs , Duty Cycle = 10%.



Typical Performance of the CGHV14500F

Test conditions unless otherwise noted: $V_D = 50 V$, $I_{DQ} = 500 mA$, $PW = 500 \mu s$, $DC = 10\%$, $P_{in} = 42 dBm$, $T_{BASE} = +25^\circ C$

Figure 1. Output Power vs Frequency as a Function of Temperature

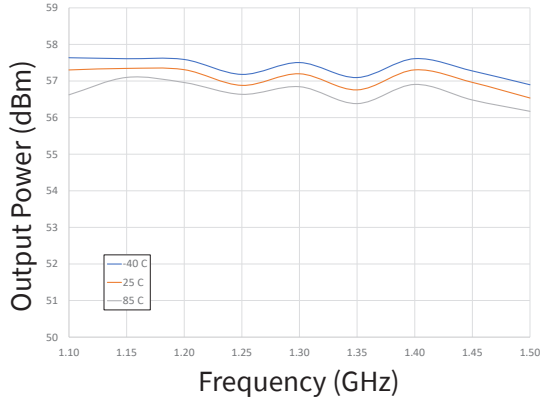

Figure 2. Drain Current vs Frequency as a Function of Temperature

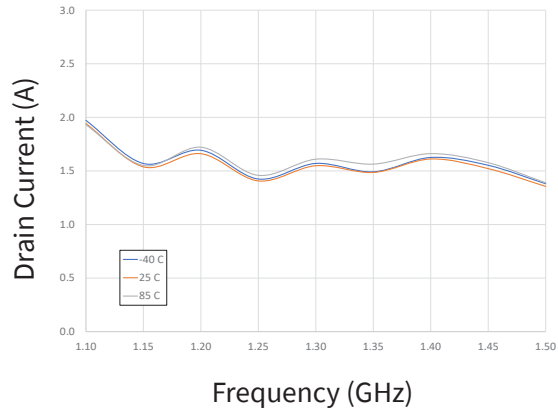

Figure 3. Power Added Eff. vs Frequency as a Function of Input Power

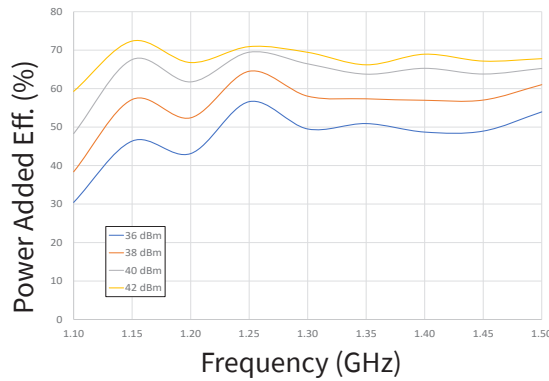

Figure 4. Output Power vs Frequency as a Function of Input Power

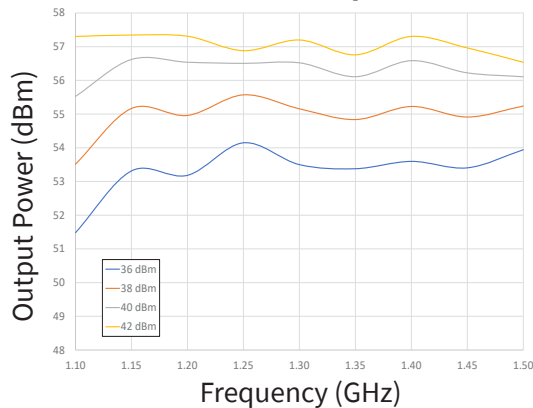
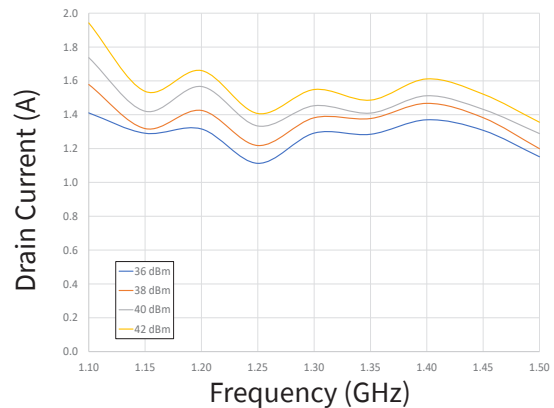

Figure 5. Drain Current vs Frequency as a Function of Input Power





Typical Performance of the CGHV14500F

Test conditions unless otherwise noted: $V_D = 50\text{ V}$, $I_{DQ} = 500\text{ mA}$, $PW = 500\text{ us}$, $DC = 10\%$, $P_{in} = 42\text{ dBm}$, $T_{BASE} = +25\text{ }^\circ\text{C}$

Figure 6. Output Power vs Frequency as a Function of Voltage

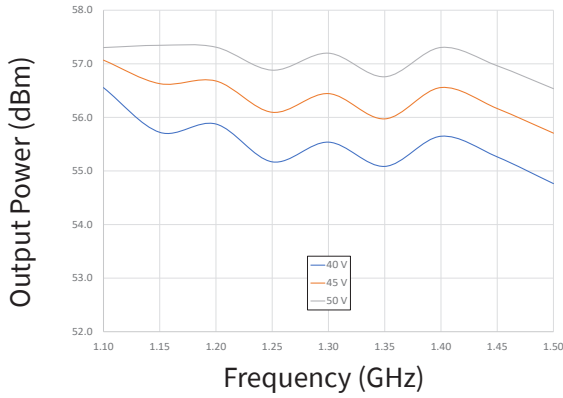

Figure 7. Output Power vs Frequency as a Function of IDQ

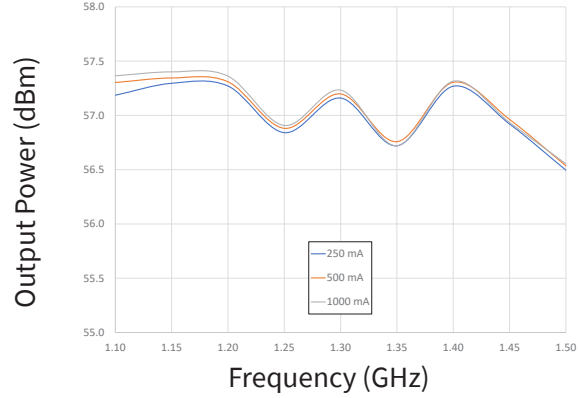

Figure 8. Power Added Eff. vs Frequency as a Function of Voltage

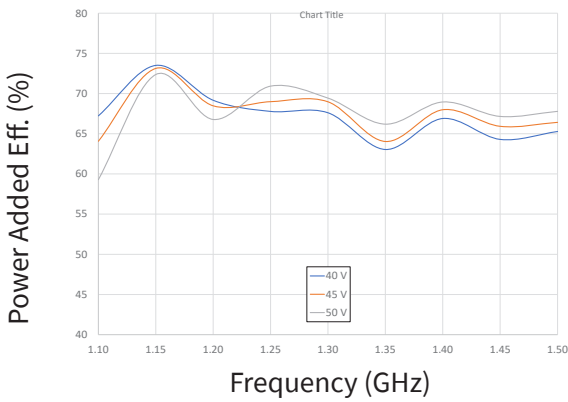

Figure 9. Power Added Eff. vs Frequency as a Function of IDQ

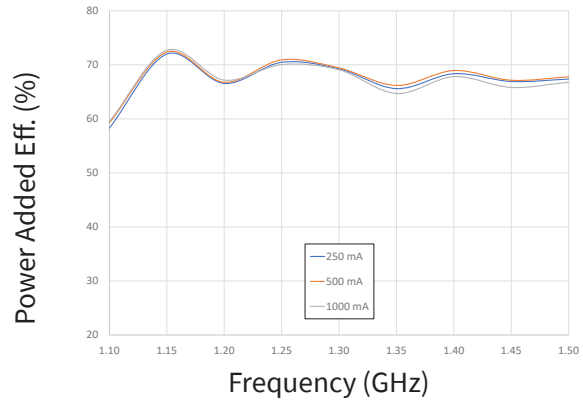

Figure 10. Drain Current vs Frequency as a Function of Voltage

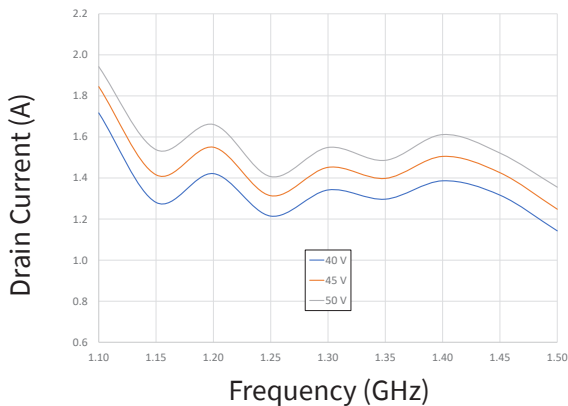
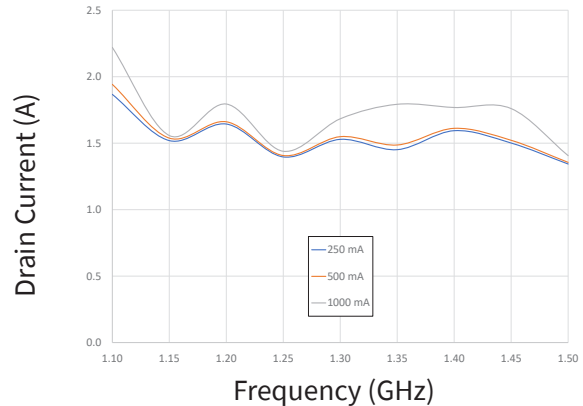

Figure 11. Drain Current vs Frequency as a Function of IDQ





Typical Performance of the CGHV14500F

Test conditions unless otherwise noted: $V_D = 50\text{ V}$, $I_{DQ} = 500\text{ mA}$, $P_W = 500\text{ us}$, $DC = 10\%$, $P_{in} = 42\text{ dBm}$, $T_{BASE} = +25\text{ }^\circ\text{C}$

Figure 12. Output Power vs Input Power as a Function of Frequency

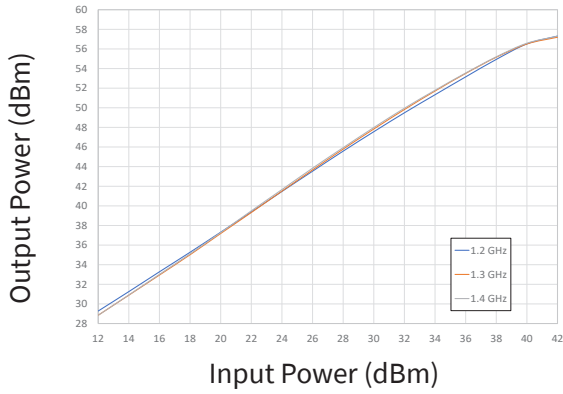

Figure 13. Power Added Eff. vs Input Power as a Function of Frequency

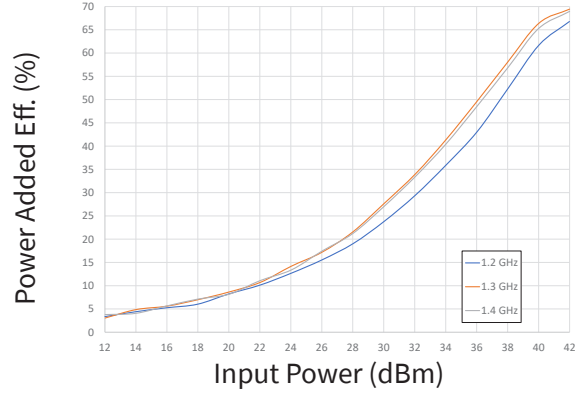

Figure 14. Large Signal Gain vs Input Power as a Function of Frequency

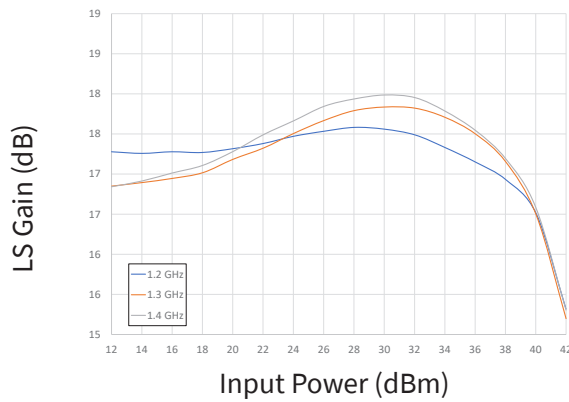

Figure 15. Drain Current vs Input Power as a Function of Frequency

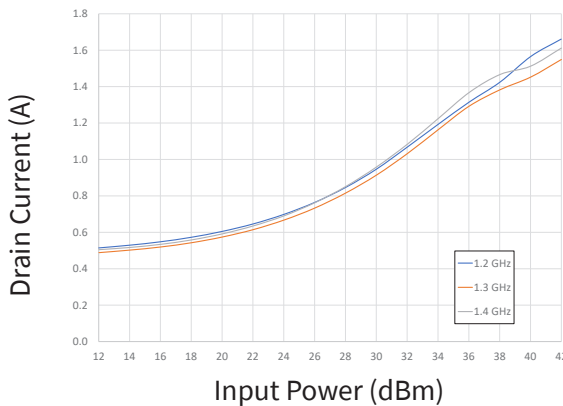
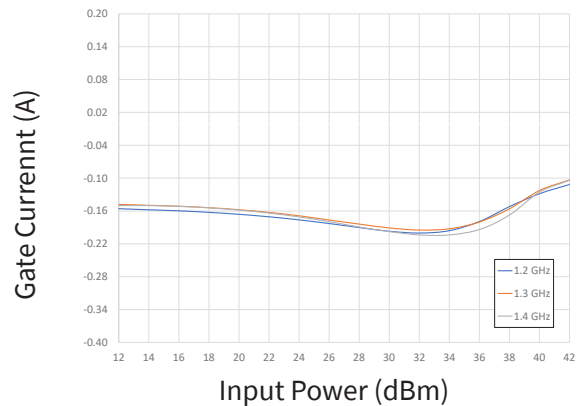

Figure 16. Gate Current vs Input Power as a Function of Frequency





Typical Performance of the CGHV14500F

Test conditions unless otherwise noted: VD = 50 V, IDQ = 500 mA, PW = 500 us, DC = 10%, Pin = 42 dBm, T_{BASE} = +25 °C

Figure 17. Output Power vs Input Power as a Function of Temperature

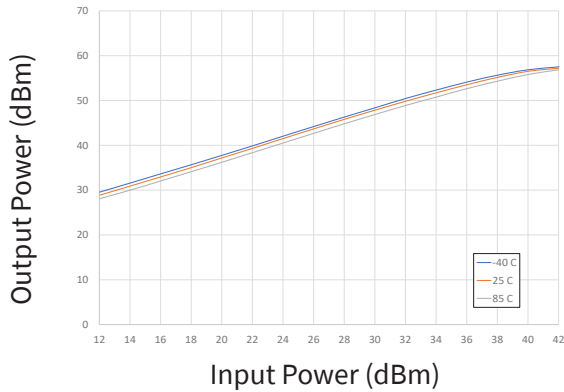

Figure 18. Large Signal Gain vs Input Power as a Function of Temperature

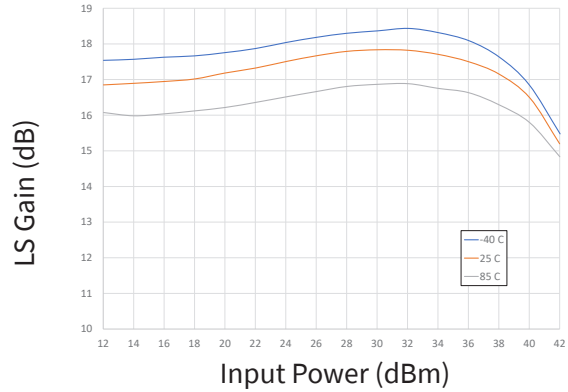

Figure 19. Drain Current vs Input Power as a Function of Temperature

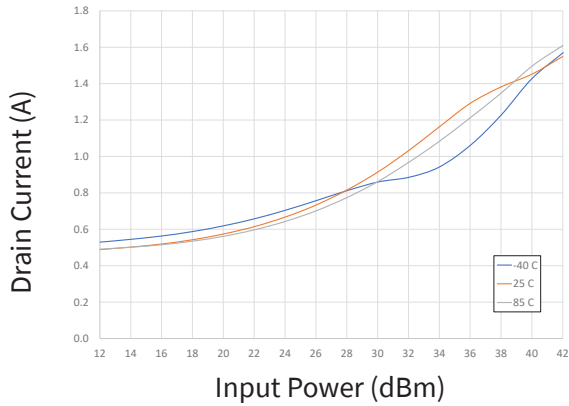
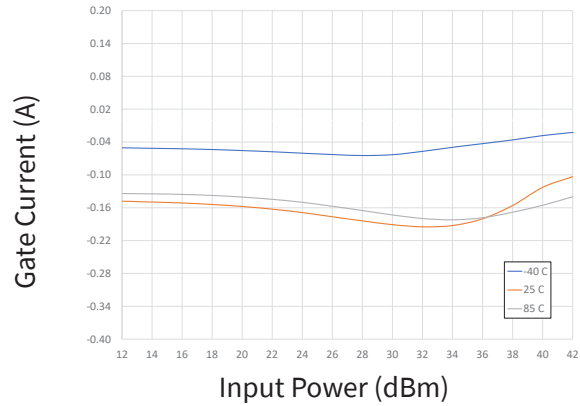

Figure 20. Gate Current vs Input Power as a Function of Temperature





Typical Performance of the CGHV14500F

Test conditions unless otherwise noted: $V_D = 50 V$, $I_{DQ} = 500 \text{ mA}$, $PW = 500 \text{ us}$, $DC = 10\%$, $P_{in} = 42 \text{ dBm}$, $T_{BASE} = +25 \text{ }^\circ\text{C}$

Figure 21. Output Power vs Input Power as a Function of IDQ

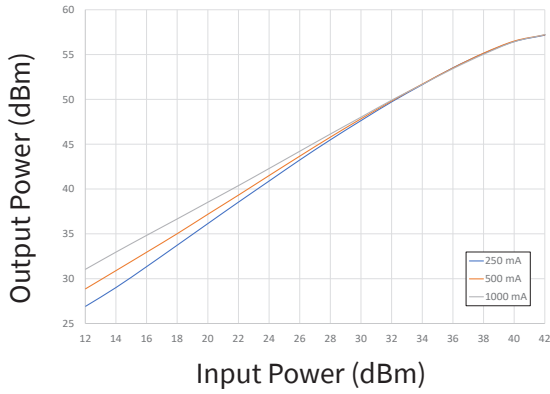

Figure 22. Power Added Eff. vs Input Power as a Function of IDQ

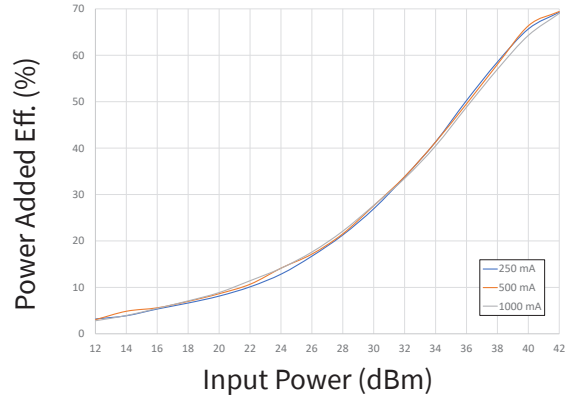

Figure 23. Large Signal Gain vs Input Power as a Function of IDQ

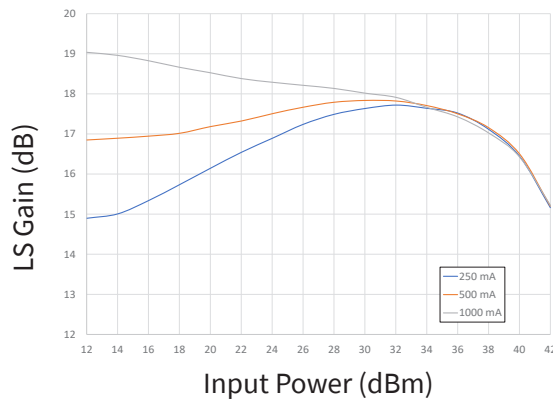

Figure 24. Drain Current vs Input Power as a Function of IDQ

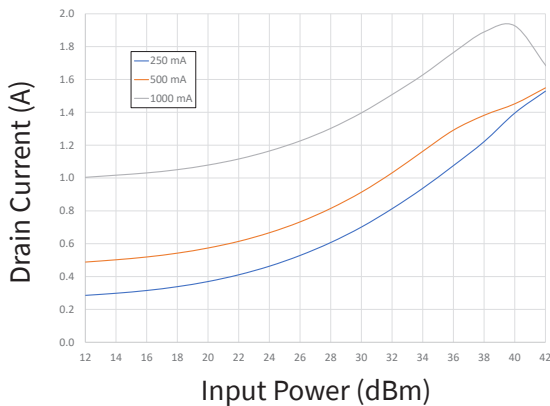
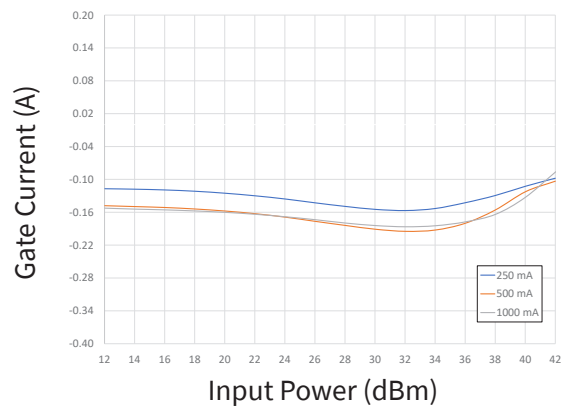

Figure 25. Gate Current vs Input Power as a Function of IDQ





Typical Performance of the CGHV14500F

Test conditions unless otherwise noted: $V_D = 50 V_D$, $I_{DQ} = 500 \text{ mA}$, CW, $P_{in} = -20 \text{ dBm}$, $T_{BASE} = +25 \text{ }^\circ\text{C}$

Figure 26. Gain vs Frequency as a Function of Temperature

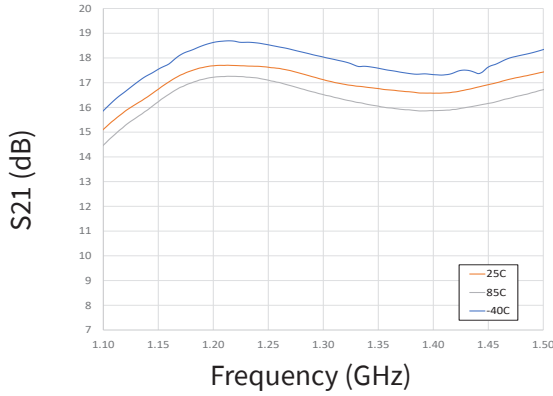

Figure 27. Gain vs Frequency as a Function of Temperature

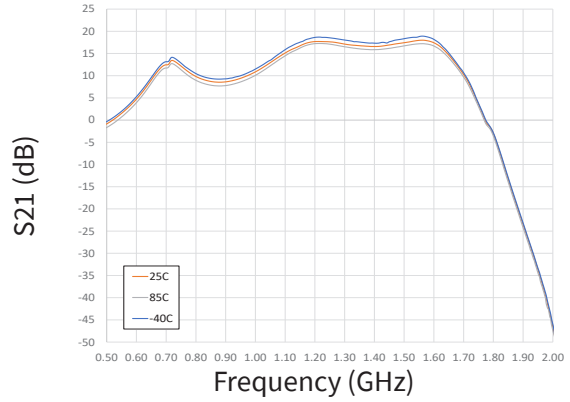

Figure 28. Input RL vs Frequency as a Function of Temperature

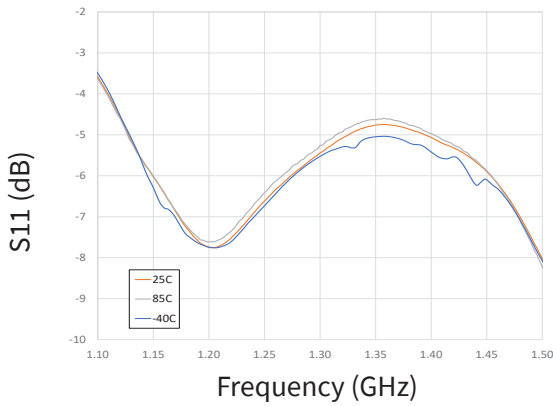

Figure 29. Input RL vs Frequency as a Function of Temperature

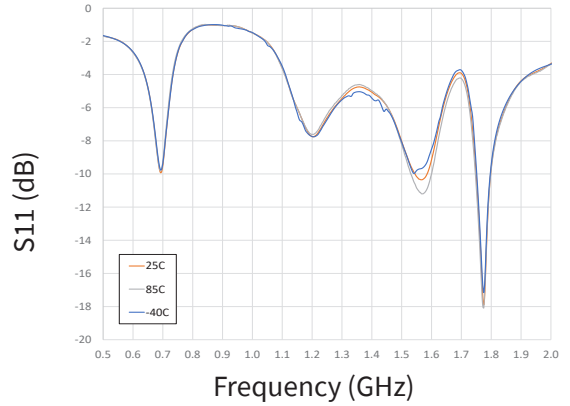

Figure 30. Output RL vs Frequency as a Function of Temperature

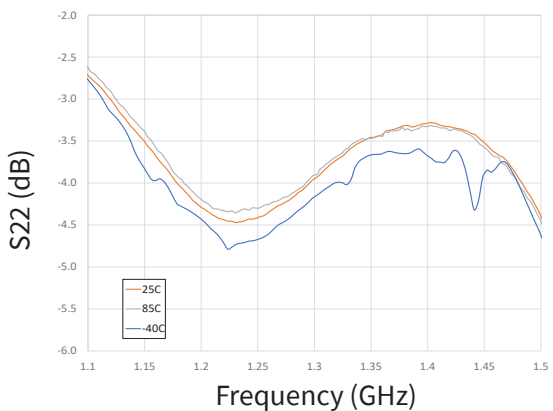
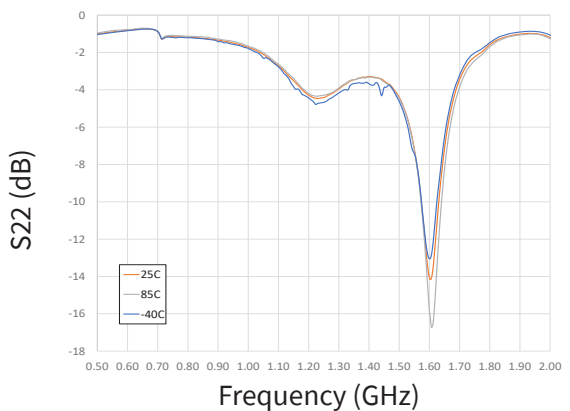

Figure 31. Output RL vs Frequency as a Function of Temperature





Typical Performance of the CGHV14500F

Test conditions unless otherwise noted: $V_D = 50 V_D$, $I_{DQ} = 500 mA$, CW, $P_{in} = -20 dBm$, $T_{BASE} = +25 ^\circ C$

Figure 32. Gain vs Frequency as a Function of Voltage

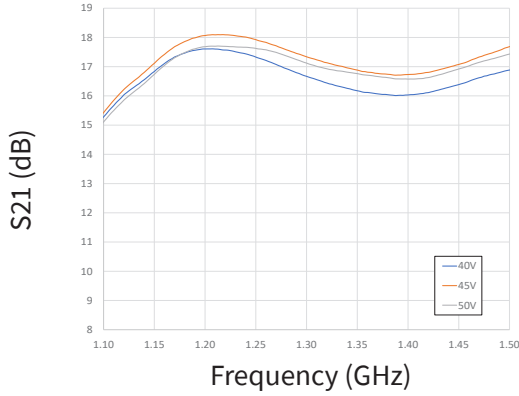

Figure 33. Gain vs Frequency as a Function of IDQ

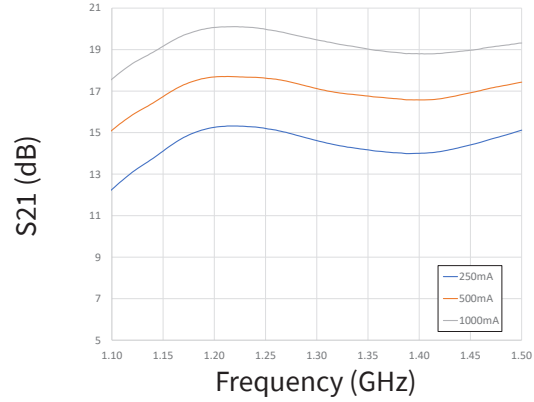

Figure 34. Input RL vs Frequency as a Function of Voltage

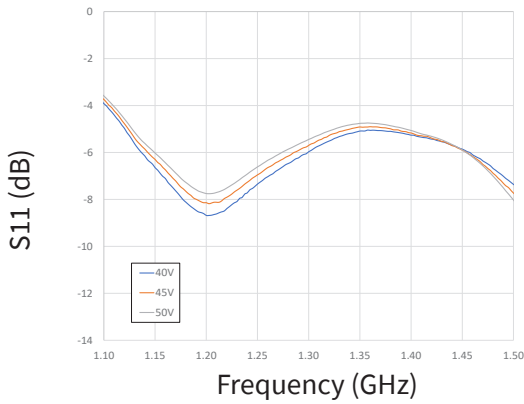

Figure 35. Input RL vs Frequency as a Function of IDQ

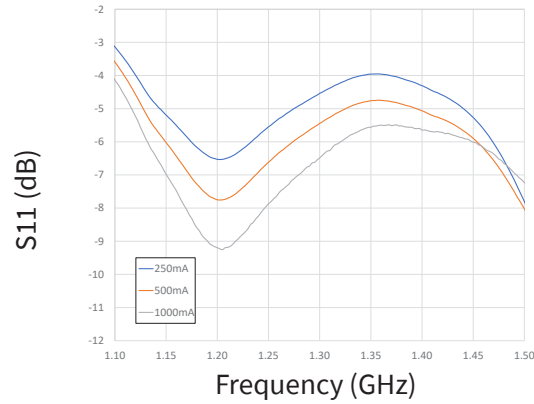

Figure 36. Output RL vs Frequency as a Function of Voltage

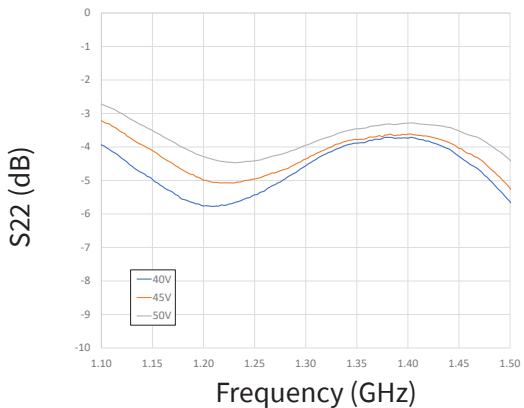
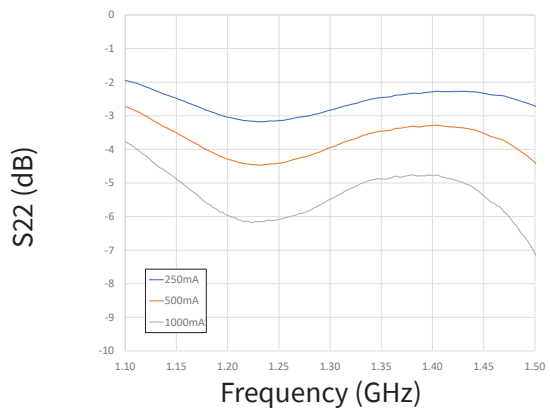

Figure 37. Output RL vs Frequency as a Function of IDQ



CGHV14500F-AMP Demonstration Amplifier Circuit Bill of Materials

Designator	Description	Qty
R1	RES, 1/16W, 0603, 1%, 562 OHMS	1
R2	RES, 5.1 OHM, +/-1%, 1/16W, 0603	1
R3	RES, 1/16W, 0603, 1%, 4700 OHMS	1
L1	INDUCTOR, CHIP, 6.8 nH, 0603 SMT	1
C1, C23	CAP, 27pF, +/- 5%, 250V, 0805, ATC 600F	2
C2	CAP, 2.0pF, +/- 0.1pF, 0603, ATC	1
C3, C4	CAP, 1.5pF, +/-0.05pF, 250V, 0805, ATC 600F	2
C5,C6	CAP, 1.8pF, +/-0.1pF, 250V, 0805, ATC 600F	2
C7,C8	CAP, 4.3pF, +/-0.1pF, 250V, 0805, ATC 600F	2
C9,C10	CAP, 7.5pF, +/-0.1pF, 250V, 0805, ATC 600F	2
C11,C24	CAP, 47pF,+/-5%, 250V, 0805, ATC 600F	2
C12,C25	CAP, 100pF, +/-5%, 250V, 0805, ATC 600F	2
C13,C26	CAP, 33000PF, 0805,100V, X7R	2
C14	CAP 10uF 16V TANTALUM	1
C15,C16	CAP, 5.6pF, +/-0.1pF, 250V, 0805, ATC 600F	2
C17,C18	CAP, 3.6pF, +/-0.1pF, 250V, 0805, ATC 600F	2
C19,C20	CAP, 2.0pF, +/-0.1pF, 250V, 0805, ATC 600F	2
C21,C22	CAP, 0.7pF, +/-0.05pF, 0805, ATC 600F	2
C27	CAP, 1.0UF, 100V, 10%, X7R, 1210	1
C28	CAP, 3300 UF, +/-20%, 100V, ELECTROLYTIC	1
J1,J2	CONN, SMA, PANEL MOUNT JACK, FL	2
J3	HEADER RT>PLZ .1CEN LK 9POS	1
J4	CONNECTOR ; SMB, Straight, JACK,SMD	1
W1	CABLE ,18 AWG, 4.2	1
	PCB, RO4350B, 0.020' MIL THK, CGHV14500, 1.2-1.4GHZ	1
Q1	CGHV14500F	1

CGHV14500F-AMP Demonstration Amplifier Circuit

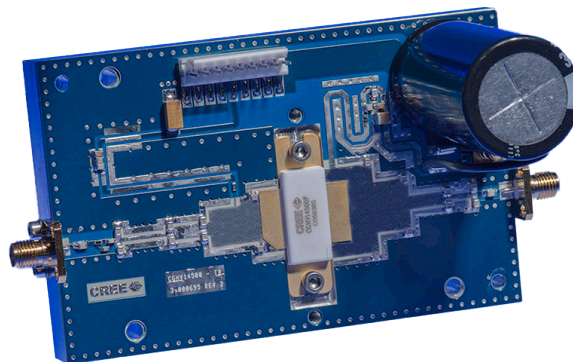

CGHV14500-AMP Demonstration Amplifier Circuit Outline

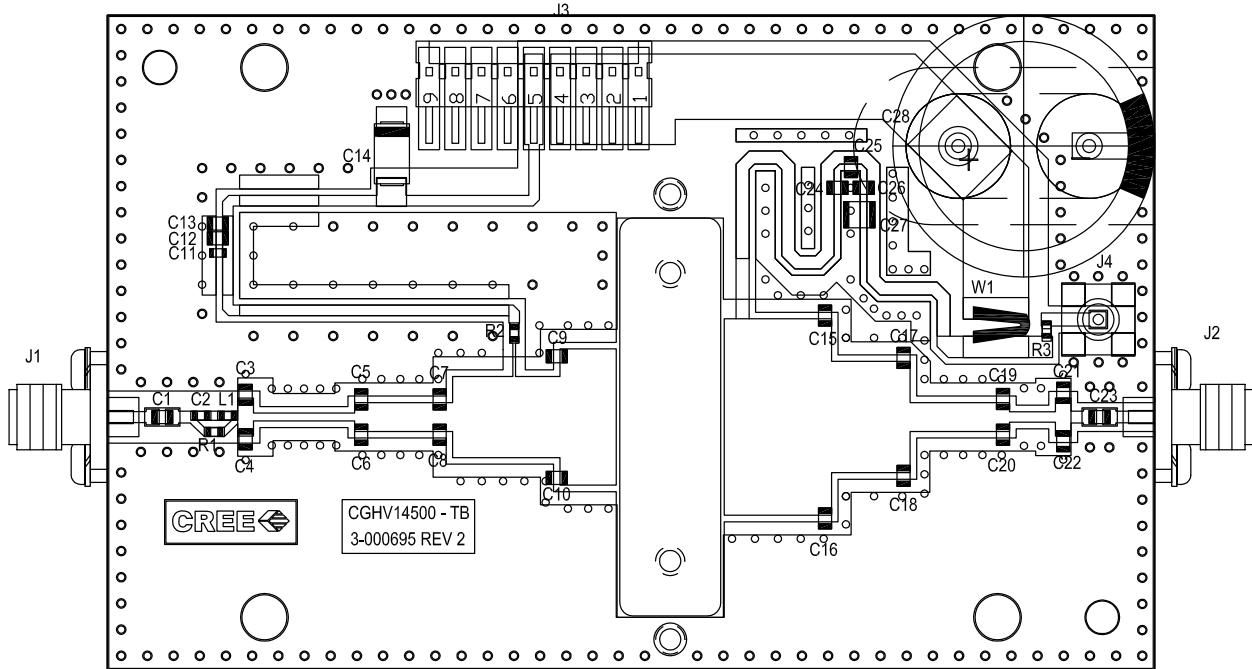

CGHV14500-AMP Demonstration Amplifier Circuit Schematic

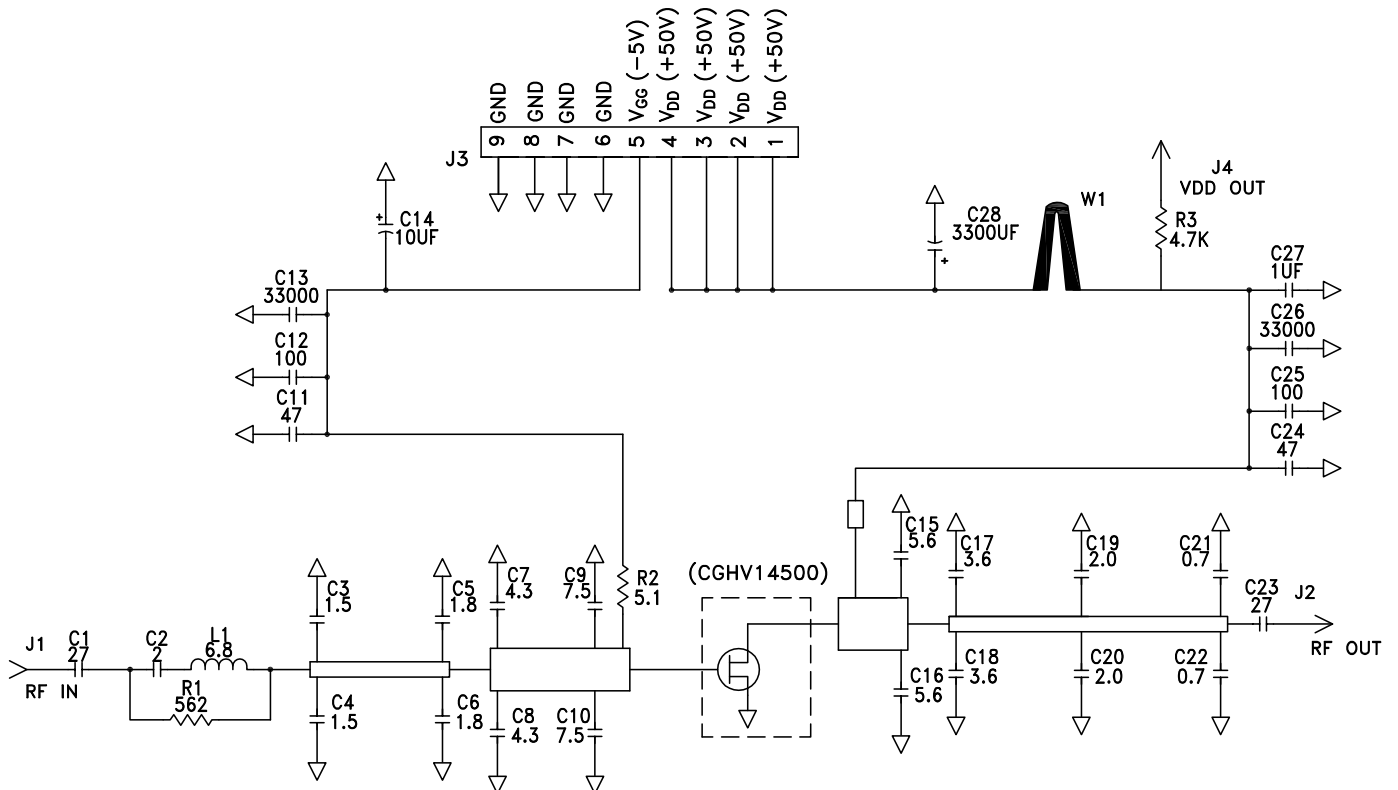

Typical Performance Over 0.96 GHz - 1.3 GHz (TC = 25 °C) of Demonstration Amplifier

Parameter	0.96 GHz	1.0 GHz	1.1 GHz	1.2 GHz	1.3 GHz	Units
Output Power	800	805	675	625	585	W
Gain	18	18.1	17.3	17.0	16.7	dB
Drain Efficiency	70	75	74	77	64	%

Note: Measured in the CGHV14500-AMP2 amplifier circuit, under 500 μs pulse width, 10% duty cycle, P_{IN} = 41 dBm.

Typical Performance - CGHV14500-AMP2

CGHV14500-AMP2 Typical Sparameters
 V_{DD} = 50 V, I_{DQ} = 500 mA

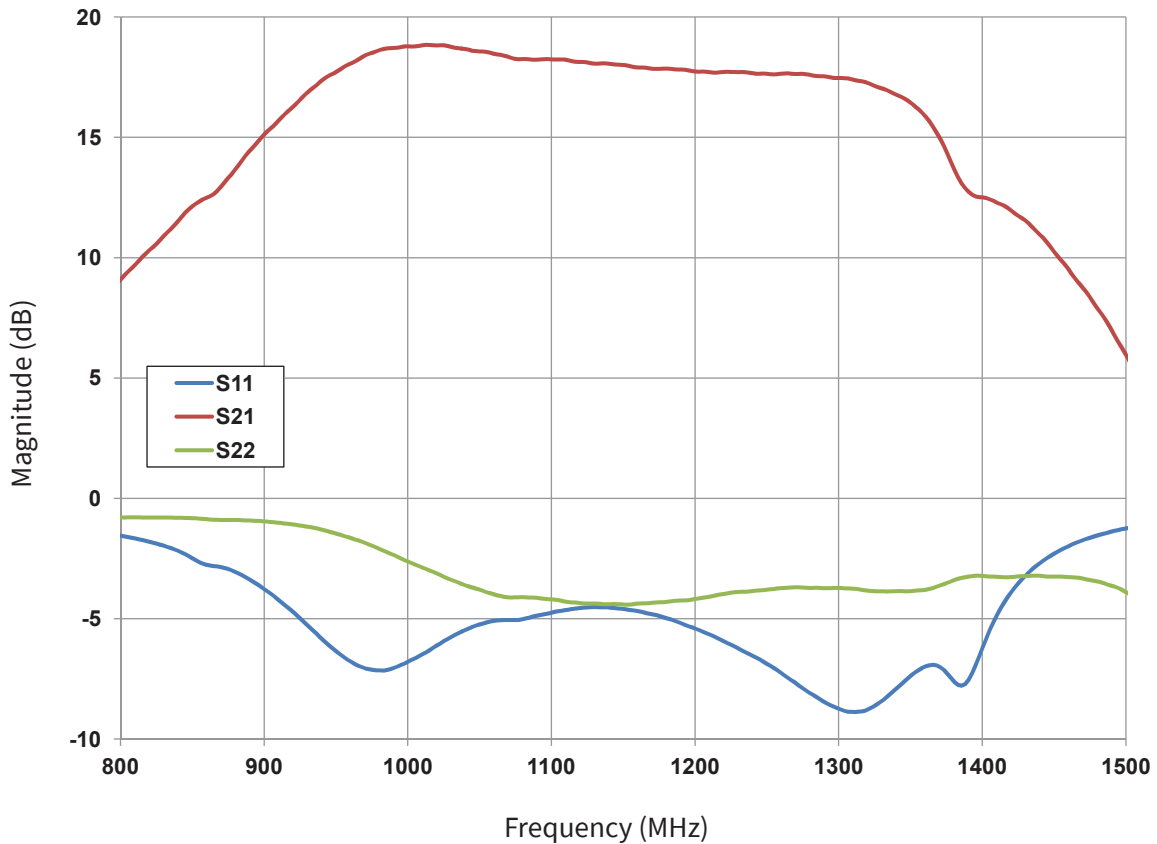



Typical Performance - CGHV14500-AMP2

Figure 2. - CGHV14500-AMP2 Typical Sparameters
VDD = 50 V, IDQ = 500 mA, PIN = 41 dBm, Pulse Width = 500 μ s, Duty Cycle 10%

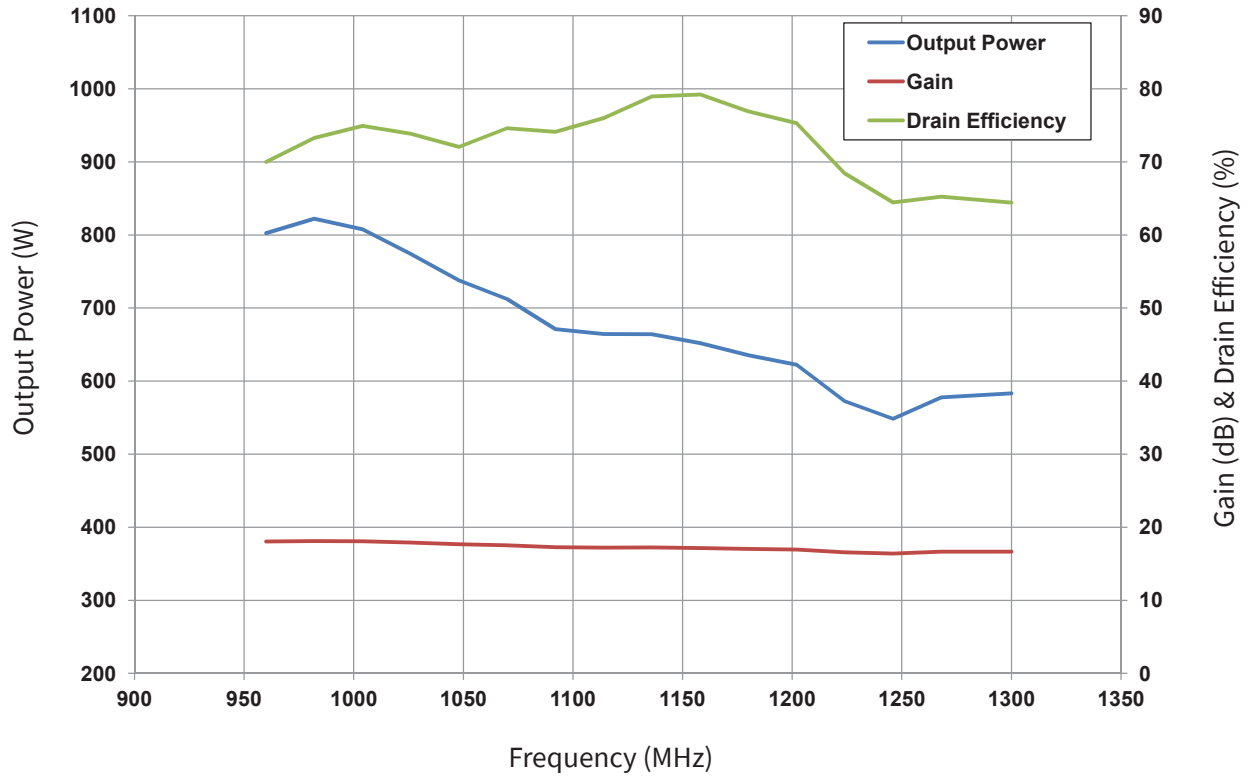

CGHV14500F-AMP2 Demonstration Amplifier Circuit Bill of Materials

Designator	Description	Qty
R1	RES,1/16W,0603,1%,562 OHMS	1
R2	RES, 5.1,OHM, +/- 1%, 1/16W,0603	1
R3	RES,1/16W,0603,1%,4.99K OHMS	1
C1, C7, C8, C23	CAP, 10pF, +/-0.1pF, 250V, 0805, ATC600F	4
C2, C15, C16	CAP, 5.6pF, +/-0.1pF, 250V, 0805, ATC600F	3
C3, C4, C5, C6	CAP, 2.2pF, +/-0.1pF, 250V, 0805, ATC600F	4
C17, C18	CAP, 2.4pF, +/-0.1pF, 250V, 0805, ATC600F	2
C19, C20	CAP, 2.0pF, +/-0.1pF, 250V, 0805, ATC600F	2
C31, C32	CAP, 2.7pF, +/-0.1pF, 250V, 0805, ATC600F	2
C22, C33	CAP, 1.5pF, +/-0.1pF, 250V, 0805, ATC600F	2
C11, C24	CAP, 47 PF +/- 5%, 250V, 0805, ATC600F	2
C12, C25	CAP, 100 PF +/- 5%, 250V, 0805, ATC 600F	2
C13, C26	CAP,33000PF, 0805,100V, X7R	2
C14	CAP 10UF 16V TANTALUM	1
C27	CAP, 1.0UF, 100V, 10%, X7R, 1210	1
C28	CAP, 3300 UF, +/-20%, 100V, ELECTROLYTIC	1
J1, J2	CONN, SMA, PANEL MOUNT JACK, FL	2
J3	HEADER RT>PLZ .1CEN LK 9POS	1
J4	CONNECTOR ; SMB, Straight, JACK,SMD	1
W1	CABLE ,18 AWG, 4.2	1
	PCB, RO4350B, 0.020" THK, CGHV14500-TB1	1
	BASEPLATE, AL, 4.00 X 2.50 X 0.49, ALTERNATE HOLE PATTERN	1

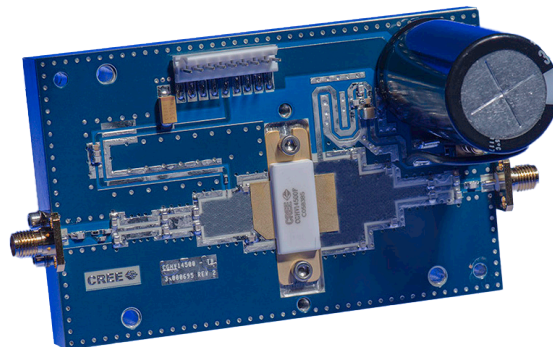
CGHV14500F-AMP2 Demonstration Amplifier Circuit

CGHV14500-AMP2 Demonstration Amplifier Circuit Outline

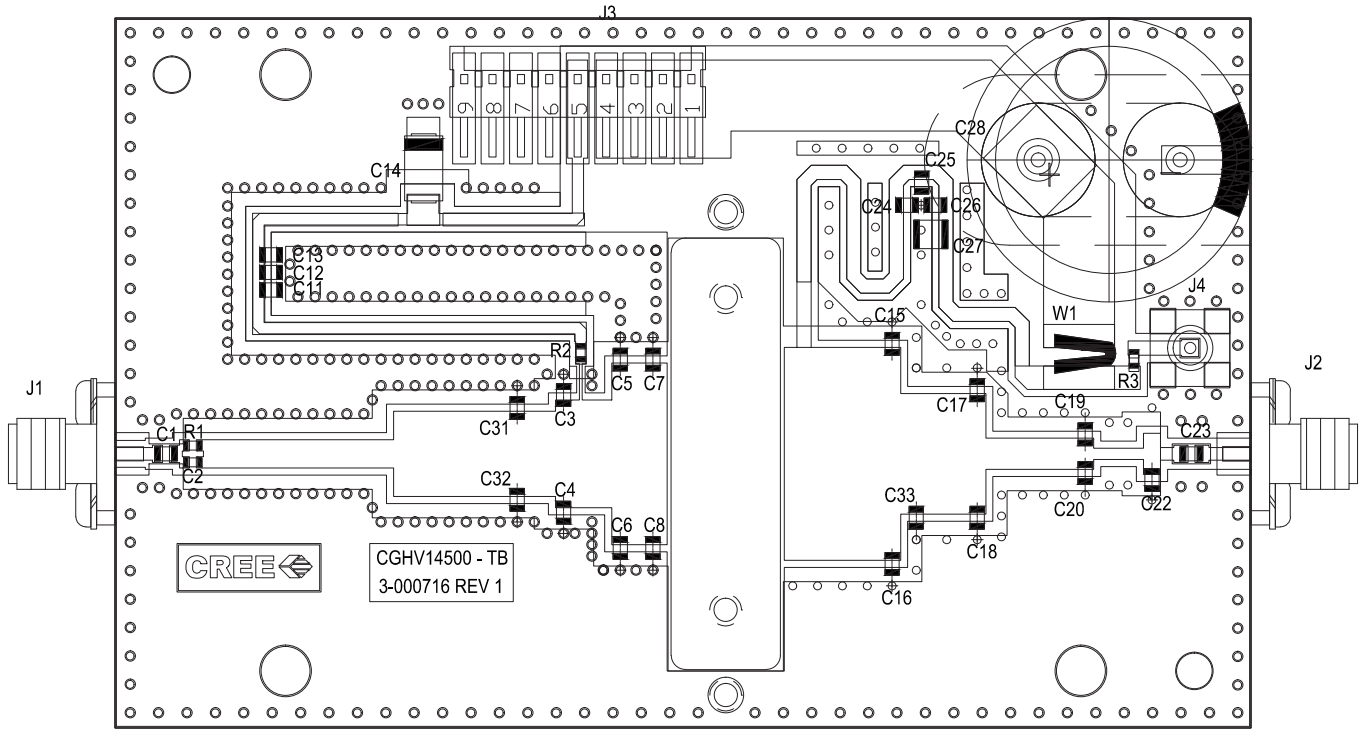

CGHV14500-AMP2 Demonstration Amplifier Circuit Schematic

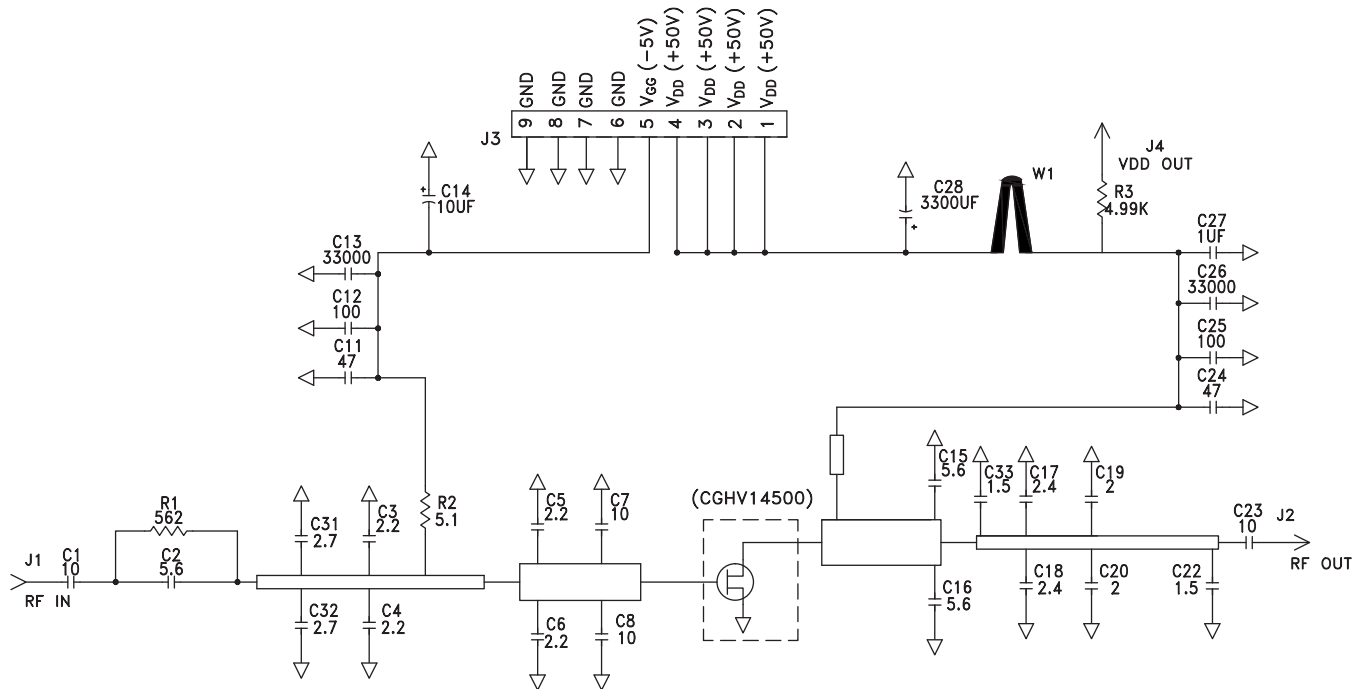

Source and Load Impedances

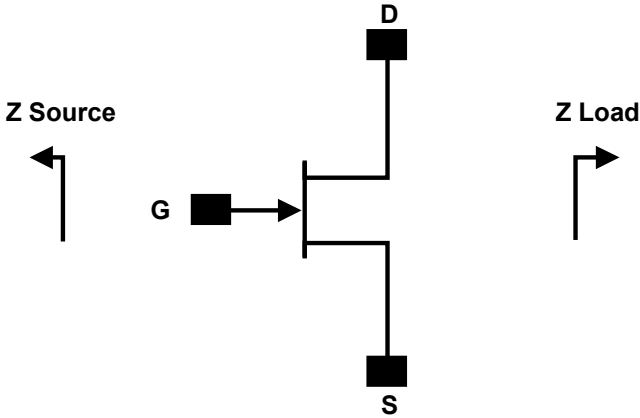

Frequency	Z Source	Z Load
900	0.3 - j0.3	2.1 + j1.4
1000	0.3 - j0.4	2.0 + j0.7
1100	0.6 - j0.4	1.8 + j0.9
1200	0.8 - j0.7	1.5 + j0.9
1300	1.1 - j0.7	1.3 + j0.7
1400	1.2 - j0.1	1.2 + j0.5
1500	1.8 - j0.1	1.1 + j0.4

- Note 1. $V_{DD} = 50\text{ V}$, $I_{DQ} = 500\text{ mA}$ in the 440117 package.
- Note 2. Optimized for power gain, P_{SAT} and Drain Efficiency
- Note 3. When using this device at low frequency, series resistors should be used to maintain amplifier stability.

CGHV14500 Power Dissipation De-rating Curve

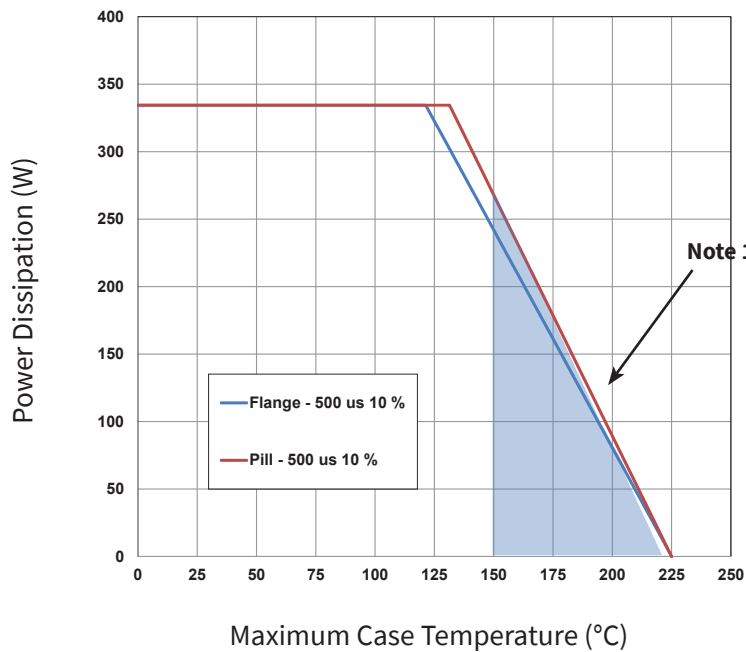

Note 1. Area exceeds Maximum Case Operating Temperature (See Page 2)

Product Dimensions CGHV14500F (Package Type — 440117)

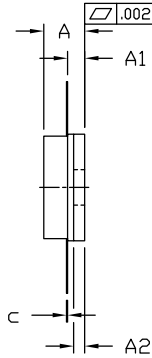
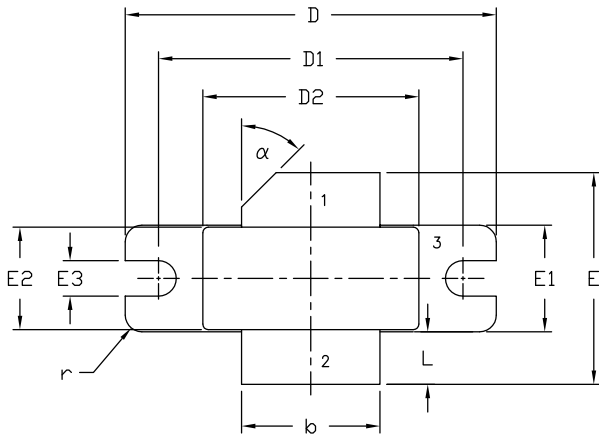

PIN 1. GATE
2. DRAIN
3. SOURCE

NOTES:

1. DIMENSIONING AND TOLERANCING PER ANSI Y14.5M - 1994.
2. CONTROLLING DIMENSION: INCH.
3. ADHESIVE FROM LID MAY EXTEND A MAXIMUM OF 0.020" BEYOND EDGE OF LID.
4. LID MAY BE MISALIGNED TO THE BODY OF PACKAGE BY A MAXIMUM OF 0.008" IN ANY DIRECTION.

DIM	INCHES		MILLIMETERS		NOTES
	MIN	MAX	MIN	MAX	
A	0.138	0.158	3.51	4.01	
A1	0.057	0.067	1.45	1.70	
A2	0.035	0.045	0.89	1.14	
b	0.495	0.505	12.57	12.83	2x
c	0.003	0.006	0.08	0.15	
D	1.335	1.345	33.91	34.16	
D1	1.095	1.105	27.81	28.07	
D2	0.773	0.787	19.63	20.00	
E	0.745	0.785	18.92	19.94	
E1	0.380	0.390	9.65	9.91	
E2	0.365	0.375	9.27	9.53	
E3	0.123	0.133	3.12	3.38	
L	0.170	0.210	4.32	5.33	2x
r	0.06 TYP		0.06 TYP		4x
α	45° REF		45° REF		

Product Dimensions CGHV14500P (Package Type — 440133)

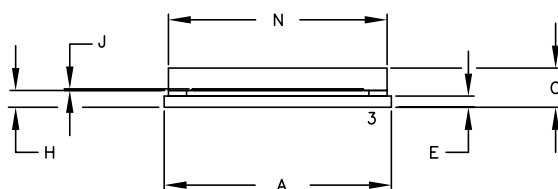
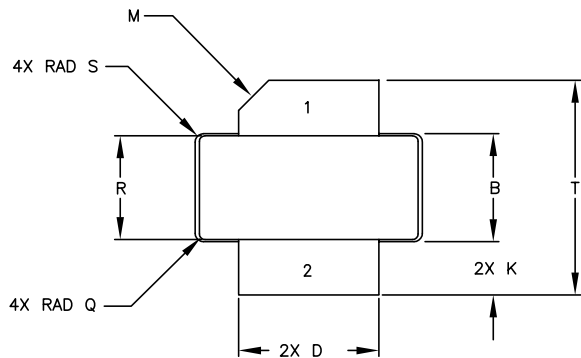

NOTES:

1. DIMENSIONING AND TOLERANCING PER ANSI Y14.5M, 1982.
2. CONTROLLING DIMENSION: INCH.
3. ADHESIVE FROM LID MAY EXTEND A MAXIMUM OF 0.020" BEYOND EDGE OF LID.
4. LID MAY BE MISALIGNED TO THE BODY OF PACKAGE BY A MAXIMUM OF 0.008" IN ANY DIRECTION.

DIM	INCHES		MILLIMETERS	
	MIN	MAX	MIN	MAX
A	0.805	0.815	20.45	20.70
B	0.380	0.390	9.65	9.91
C	0.135	0.149	3.43	3.78
D	0.495	0.505	12.57	12.83
E	0.035	0.045	.89	1.14
H	0.057	0.067	1.45	1.70
J	0.003	0.006	.08	.15
K	0.170	0.210	4.32	5.33
M	45° REF		45° REF	
N	0.773	0.787	19.63	19.99
Q	0.020 REF		0.51 REF	
R	0.364	0.374	9.25	9.50
S	0.030 REF		0.76 REF	
T	0.745	0.785	18.92	19.94

STYLE 1:

PIN 1. GATE
2. DRAIN
3. SOURCE

Part Number System

CGHV14500F

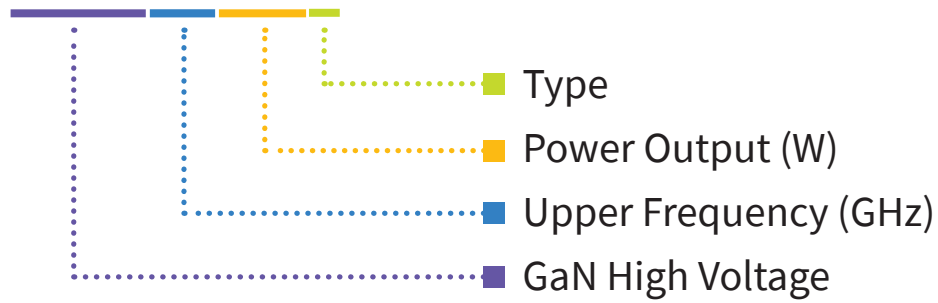

Table 1

Parameter	Value	Units
Upper Frequency ¹	1.4	GHz
Power Output	500	W
Type	F = Flanged P = Package	-

¹ Alpha characters used in frequency code indicate a value greater than 9.9 GHz. See Table 2 for value.



Table 2

Character Code	Code Value
A	0
B	1
C	2
D	3
E	4
F	5
G	6
H	7
J	8
K	9

Examples: 1A = 10.0 GHz
2H = 27.0 GHz

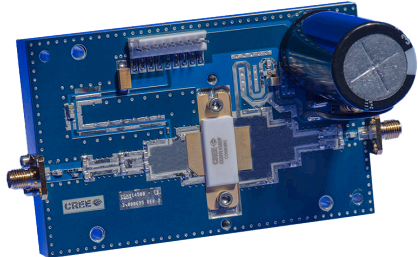

Product Ordering Information

Order Number	Description	Unit of Measure	Image
CGHV14500F	GaN HEMT	Each	
CGHV14500P	GaN HEMT	Each	
CGHV14500F-AMP	Test board with GaN HEMT installed	Each	



For more information, please contact:

4600 Silicon Drive
Durham, North Carolina, USA 27703
www.wolfspeed.com/RF

Sales Contact
RFSales@cree.com

Notes

Disclaimer

Specifications are subject to change without notice. “Typical” parameters are the average values expected by Cree in large quantities and are provided for information purposes only. Cree products are not warranted or authorized for use as critical components in medical, life-saving, or life-sustaining applications, or other applications where a failure would reasonably be expected to cause severe personal injury or death. No responsibility is assumed by Cree for any infringement of patents or other rights of third parties which may result from use of the information contained herein. No license is granted by implication or otherwise under any patent or patent rights of Cree.

X-ON Electronics

Largest Supplier of Electrical and Electronic Components

Click to view similar products for [RF Development Tools](#) category:

Click to view products by [Wolfspeed](#) manufacturer:

Other Similar products are found below :

[MAAM-011117](#) [MAAP-015036-DIEEV2](#) [EV1HMC1113LP5](#) [EV1HMC6146BLC5A](#) [EV1HMC637ALP5](#) [EVAL-ADG919EBZ](#) [ADL5363-EVALZ](#) [LMV228SDEVAL](#) [SKYA21001-EVB](#) [SMP1331-085-EVB](#) [EV1HMC618ALP3](#) [EVAL01-HMC1041LC4](#) [MAAL-011111-000SMB](#)
[MAAM-009633-001SMB](#) [107712-HMC369LP3](#) [107780-HMC322ALP4](#) [SP000416870](#) [EV1HMC470ALP3](#) [EV1HMC520ALC4](#)
[EV1HMC244AG16](#) [MAX2614EVKIT#](#) [124694-HMC742ALP5](#) [SC20ASATEA-8GB-STD](#) [MAX2837EVKIT+](#) [MAX2612EVKIT#](#)
[MAX2692EVKIT#](#) [EV1HMC629ALP4E](#) [SKY12343-364LF-EVB](#) [108703-HMC452QS16G](#) [EV1HMC863ALC4](#) [EV1HMC427ALP3E](#)
[119197-HMC658LP2](#) [EV1HMC647ALP6](#) [ADL5725-EVALZ](#) [106815-HMC441LM1](#) [EV1HMC1018ALP4](#) [UXN14M9PE](#) [MAX2016EVKIT](#)
[EV1HMC939ALP4](#) [MAX2410EVKIT](#) [MAX2204EVKIT+](#) [EV1HMC8073LP3D](#) [SIMSA868-DKL](#) [SIMSA868C-DKL](#) [SKY65806-636EK1](#)
[SKY68020-11EK1](#) [SKY67159-396EK1](#) [SKY66181-11-EK1](#) [SKY65804-696EK1](#) [SKY13396-397LF-EVB](#)