

# CGHV40100

100 W, DC - 3.0 GHz, 50 V, GaN HEMT

## Description

Cree's CGHV40100 is an unmatched, gallium nitride (GaN) high electron mobility transistor (HEMT). The CGHV40100, operating from a 50 volt rail, offers a general purpose, broadband solution to a variety of RF and microwave applications. GaN HEMTs offer high efficiency, high gain and wide bandwidth capabilities making the CGHV40100 ideal for linear and compressed amplifier circuits. The transistor is available in a 2-lead flange and pill package.

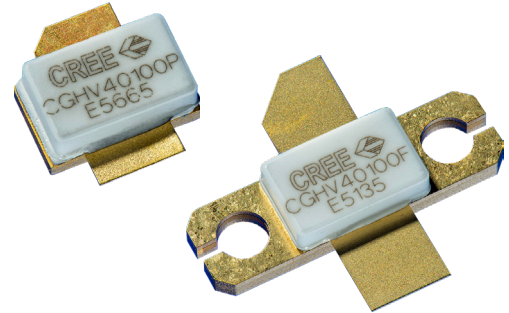

Package Types: 440193 & 440206  
PN: CGHV40100F & CGHV40100P

## Typical Performance Over 500 MHz - 2.5 GHz ( $T_c = 25^\circ\text{C}$ ), 50 V

Parameter	500 MHz	1.0 GHz	1.5 GHz	2.0 GHz	2.5 GHz	Units
Small Signal Gain	17.6	16.9	17.7	17.5	14.8	dB
Saturated Output Power	147	100	141	116	112	W
Drain Efficiency @ $P_{SAT}$	68	56	58	54	54	%
Input Return Loss	6	5.1	10.5	5.5	8.8	dB

Notes: Measured CW in the CGHV40100F-AMP application circuit.

## Features

- Up to 3 GHz Operation
- 100 W Typical Output Power
- 17.5 dB Small Signal Gain at 2.0 GHz
- Application Circuit for 0.5 - 2.5 GHz
- 55% Efficiency at  $P_{SAT}$
- 50 V Operation

 Large Signal Models Available for ADS and MWO

**RoHS**  
COMPLIANT



### Absolute Maximum Ratings (not simultaneous) at 25 °C Case Temperature

Parameter	Symbol	Rating	Units	Conditions
Drain-Source Voltage	$V_{DSS}$	150	Volts	25 °C
Gate-to-Source Voltage	$V_{GS}$	-10, +2	Volts	25 °C
Storage Temperature	$T_{STG}$	-65, +150	°C	
Operating Junction Temperature	$T_J$	225	°C	
Maximum Forward Gate Current	$I_{GMAX}$	20.8	mA	25 °C
Maximum Drain Current <sup>1</sup>	$I_{DMAX}$	8.7	A	25 °C
Soldering Temperature <sup>2</sup>	$T_S$	245	°C	
Screw Torque	$\tau$	40	in-oz	
Thermal Resistance, Junction to Case <sup>3</sup>	$R_{\theta JC}$	1.62	°C/W	85 °C
Thermal Resistance, Junction to Case <sup>4</sup>	$R_{\theta JC}$	1.72	°C/W	85 °C
Case Operating Temperature <sup>5</sup>	$T_C$	-40, +150	°C	

#### Notes:

<sup>1</sup> Current limit for long term, reliable operation

<sup>2</sup> Refer to the Application Note on soldering at [wolfspeed.com/rf/document-library](http://wolfspeed.com/rf/document-library)

<sup>3</sup> Measured for the CGHV40100P at  $P_{DISS} = 83$  W

<sup>4</sup> Measured for the CGHV40100F at  $P_{DISS} = 83$  W

<sup>5</sup> See also, Power Derating Curve on Page 5

### Electrical Characteristics ( $T_C = 25$ °C)

Characteristics	Symbol	Min.	Typ.	Max.	Units	Conditions
<b>DC Characteristics<sup>1</sup></b>						
Gate Threshold Voltage	$V_{GS(th)}$	-3.8	-3.0	-2.3	$V_{DC}$	$V_{DS} = 10$ V, $I_D = 20.8$ mA
Gate Quiescent Voltage	$V_{GS(Q)}$	-	-2.7	-	$V_{DC}$	$V_{DS} = 50$ V, $I_D = 0.6$ A
Saturated Drain Current <sup>2</sup>	$I_{DS}$	13.5	19.3	-	A	$V_{DS} = 6.0$ V, $V_{GS} = 2.0$ V
Drain-Source Breakdown Voltage	$V_{BR}$	100	-	-	$V_{DC}$	$V_{GS} = -8$ V, $I_D = 20.8$ mA
<b>RF Characteristics<sup>3</sup> (<math>T_C = 25</math> °C, <math>F_0 = 2.0</math> GHz unless otherwise noted)</b>						
Small Signal Gain	$G_{SS}$	16	17.5	-	dB	$V_{DD} = 50$ V, $I_{DQ} = 0.6$ A
Power Gain	$G_P$	-	11.0	-	dB	$V_{DD} = 50$ V, $I_{DQ} = 0.6$ A, $P_{OUT} = P_{SAT}$
Output Power at Saturation <sup>4</sup>	$P_{SAT}$	100	116	-	W	$V_{DD} = 50$ V, $I_{DQ} = 0.6$ A
Drain Efficiency	$\eta$	47	54	-	%	$V_{DD} = 50$ V, $I_{DQ} = 0.6$ A, $P_{OUT} = P_{SAT}$
Output Mismatch Stress	VSWR	-	-	10 : 1	$\Psi$	No damage at all phase angles, $V_{DD} = 50$ V, $I_{DQ} = 0.6$ A, $P_{OUT} = 100$ W CW
<b>Dynamic Characteristics<sup>5</sup></b>						
Input Capacitance	$C_{GS}$	-	29.3	-	pF	$V_{DS} = 50$ V, $V_{GS} = -8$ V, $f = 1$ MHz
Output Capacitance	$C_{DS}$	-	7.3	-	pF	$V_{DS} = 50$ V, $V_{GS} = -8$ V, $f = 1$ MHz
Feedback Capacitance	$C_{GD}$	-	0.61	-	pF	$V_{DS} = 50$ V, $V_{GS} = -8$ V, $f = 1$ MHz

#### Notes:

<sup>1</sup> Measured on wafer prior to packaging

<sup>2</sup> Scaled from PCM data

<sup>3</sup> Measured in CGHV40100-AMP

<sup>4</sup>  $P_{SAT}$  is defined as  $I_G = 0.208$  mA

<sup>5</sup> Includes package



**CGHV40100 Typical Performance**

**Figure 1. Small Signal Gain and Return Losses versus Frequency measured in application circuit CGHV40100-AMP**  
 $V_{DD} = 50\text{ V}$ ,  $I_{DQ} = 600\text{ mA}$ ,  $T_{case} = 25^\circ\text{C}$

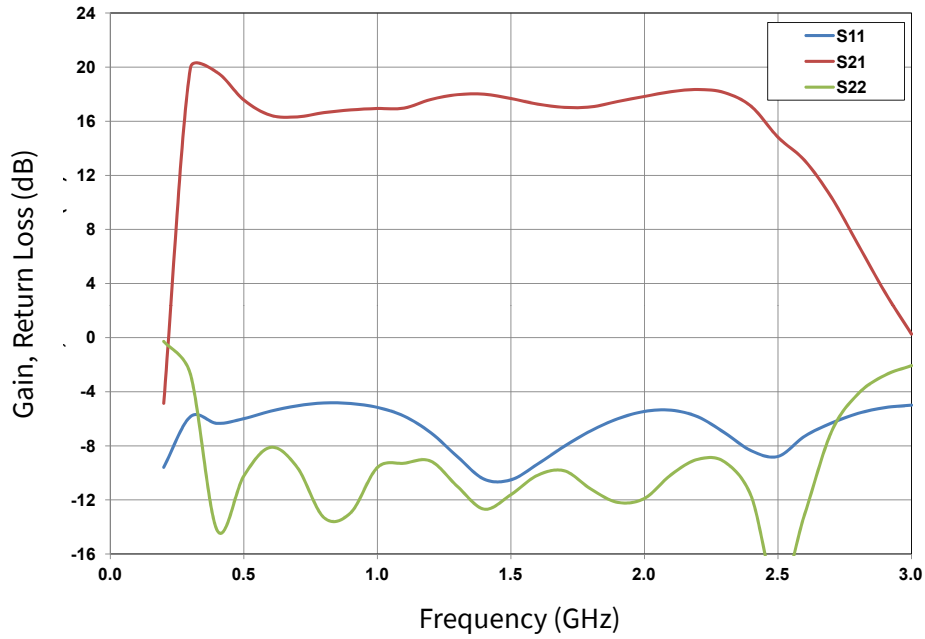

**Figure 2. Output Power and Drain Efficiency vs Frequency**  
 $V_{DD} = 50\text{ V}$ ,  $I_{DQ} = 600\text{ mA}$

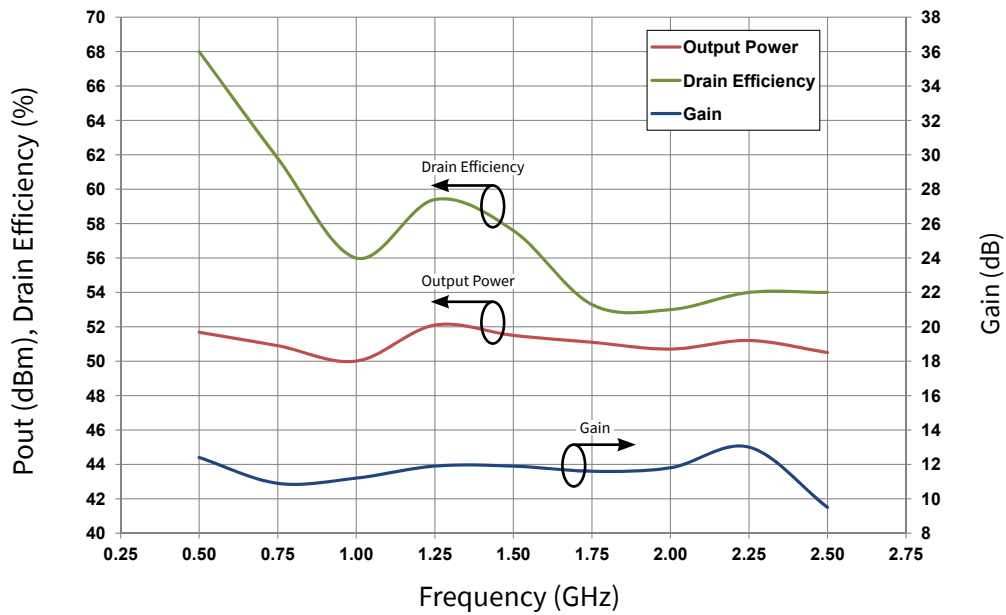



**CGHV40100 Typical Performance**

**Figure 3. Third Order Intermodulation Distortion vs Average Output Power measured in Broadband Amplifier Circuit CGHV40100-AMP  
Spacing = 1 MHz,  $V_{DD} = 50\text{ V}$ ,  $I_{DQ} = 600\text{ mA}$ ,  $T_{case} = 25^\circ\text{C}$**

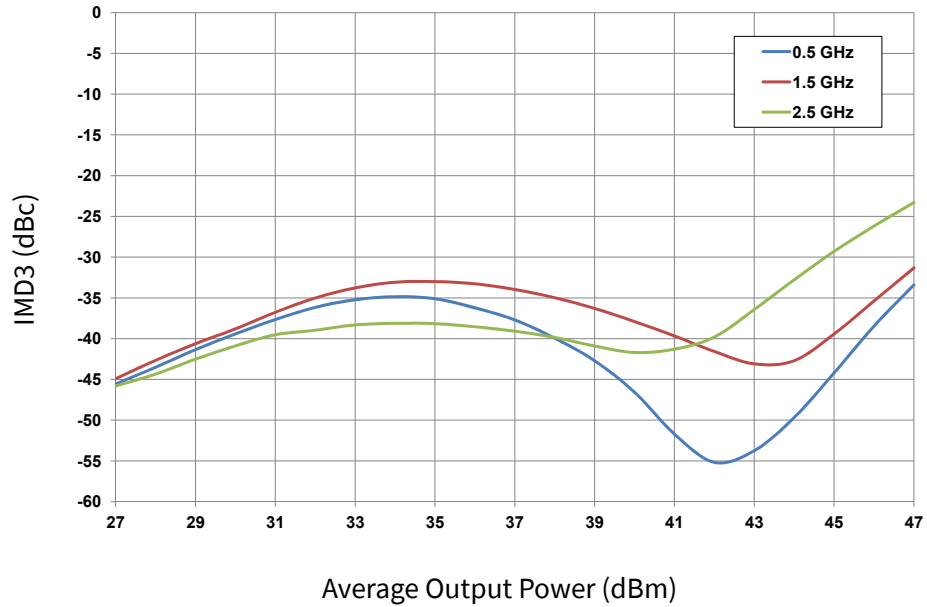

**Figure 4. Third Order Intermodulation Distortion vs Frequency measured in Broadband Amplifier Circuit CGHV40100-AMP  
Spacing = 1 MHz,  $V_{DD} = 50\text{ V}$ ,  $I_{DQ} = 600\text{ mA}$ ,  $T_{case} = 25^\circ\text{C}$**

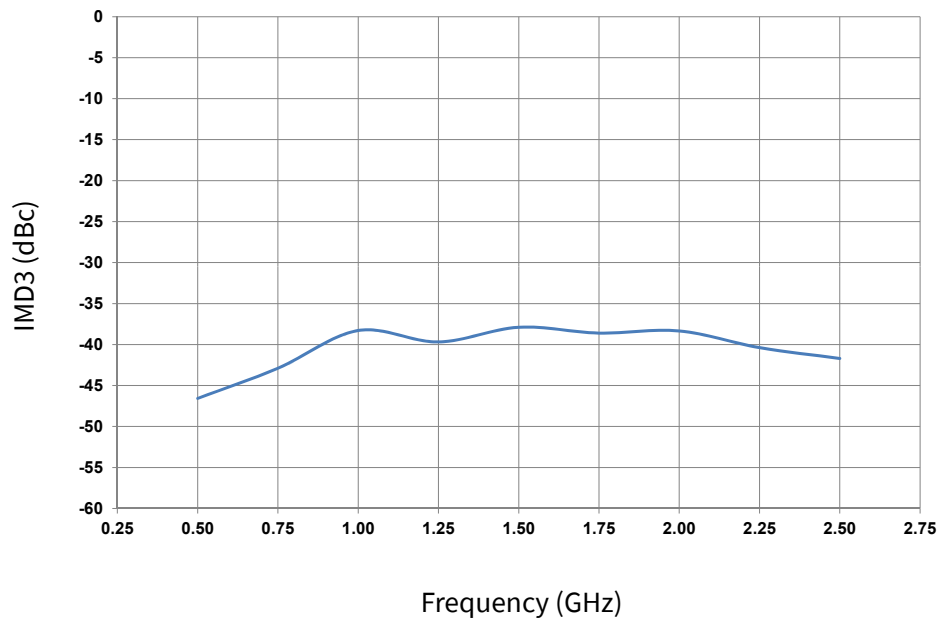



**CGHV40100 Typical Performance**

**Figure 5.  $G_{MAX}$  and K-Factor vs Frequency**  
 $V_{DD} = 50\text{ V}$ ,  $I_{DQ} = 600\text{ mA}$ ,  $T_{case} = 25^\circ\text{C}$

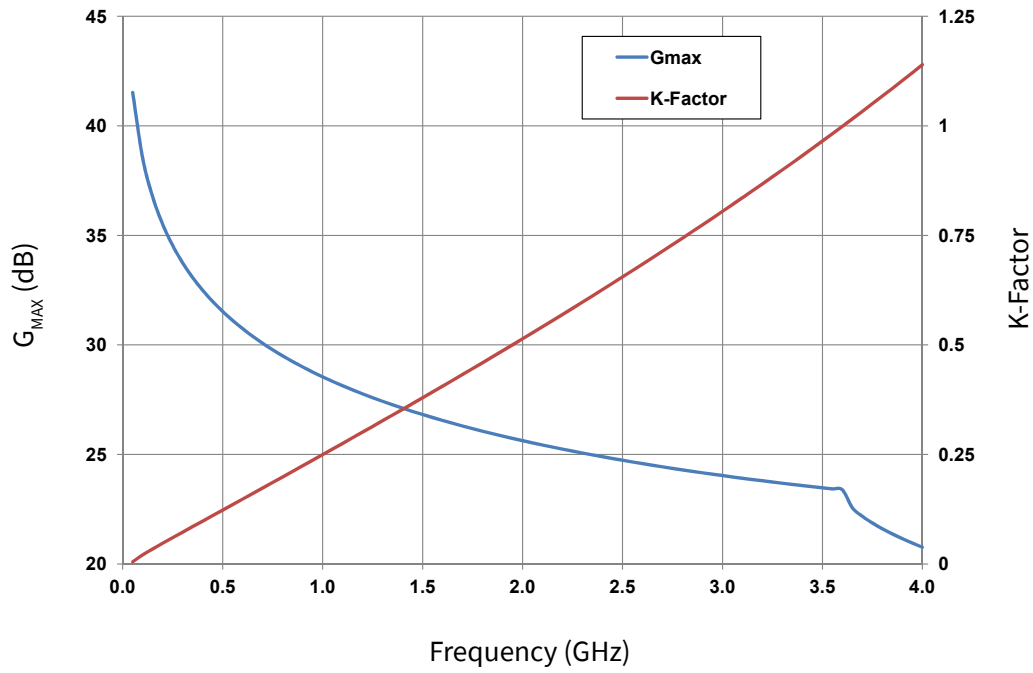



### CGHV40100-AMP Application Circuit Schematic

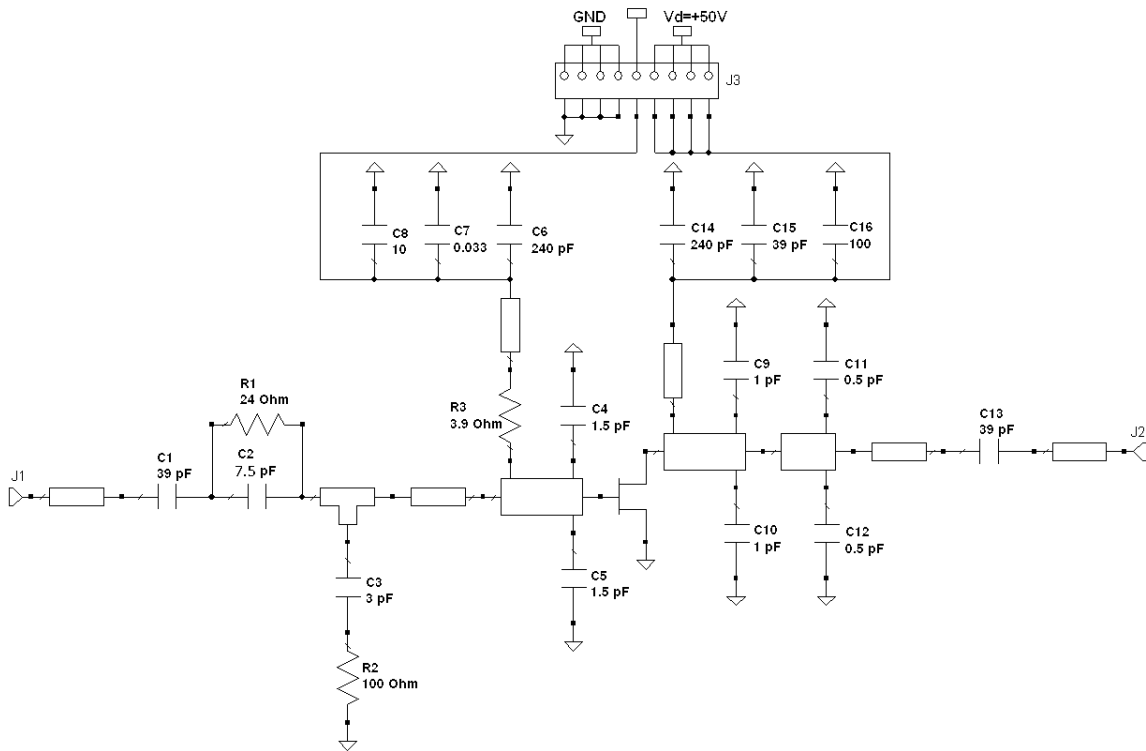

### CGHV40100-AMP Application Circuit

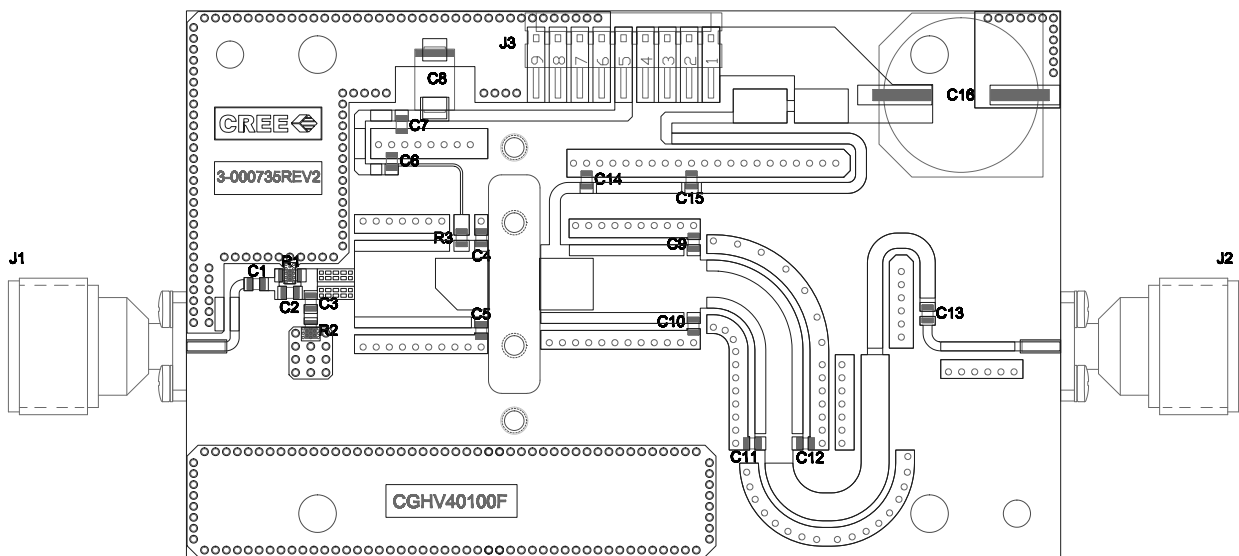



## CGHV40100-AMP Application Circuit Bill of Materials

Designator	Description	Qty
C1, C13, C15	CAP, 39 pF, $\pm 0.1$ pF, 250V, 0805, ATC600F	3
C2	CAP, 7.5 pF, $\pm 0.1$ pF, 250 V, 0806, ATC600F	1
C3	CAP, 3 pF $\pm 0.1$ pF, 250 V, 0805, ATC600F	1
C4, C5	CAP, 1.5 pF, $\pm 0.1$ pF, 250 V, 0805, ATC600F	2
C7	CAP, 33000 pF, 0805 100V, X7R	1
C6, C14	CAP, 240 pF, $\pm 0.5$ pF, 250 V, 0805, ATC600F	2
C8	CAP, 10 UF, 16V TANTALUM, 2312	1
C9, C10	CAP, 1 pF, $\pm 0.1$ pF, 250 V, 0805, ATC600F	2
C11, C12	CAP, 0.5 pF, $\pm 0.1$ pF, 250 V, 0805, ATC600F	2
C16	CAP, 100 UF, 20%, 160 V, ELEC	1
R1	RES, 24 OHMS, IMS ND3-1005CS24R0G	1
R2	RED, 100 OHMS, IMS ND3-0805EW1000G	1
R3	RES, 3.9 OHMS, 0805	1
J1, J2	CONN, SMA, PANEL MOUNT JACK	2
J3	HEADER RT>PLZ .1CEN LK 9POS	1
-	BASEPLATE, CGH35120	1
-	PCB, RO4350B, 2.5" X 4" X 0.020", CGHV40100F	1

## CGHV40100-AMP Demonstration Amplifier Circuit

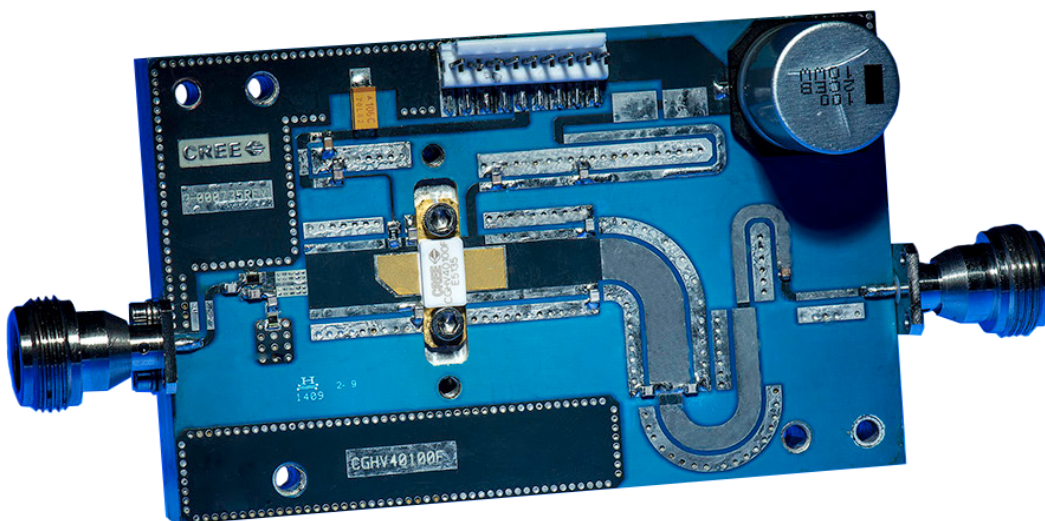



### Electrical Characteristics When Tested in CGHV40100F-AMP2

Characteristics	Symbol	Min.	Typ.	Max.	Units	Conditions
<b>RF Characteristics<sup>1</sup> (T<sub>c</sub> = 25 °C, F<sub>o</sub> = 1.2 - 1.4 GHz unless otherwise noted)</b>						
Output Power	P <sub>OUT</sub>	-	51	-	dBm	V <sub>DD</sub> = 50 V, I <sub>DQ</sub> = 10 mA, P <sub>IN</sub> = 38 dBm
Drain Efficiency	η	-	72	-	%	V <sub>DD</sub> = 50 V, I <sub>DQ</sub> = 10 mA, P <sub>IN</sub> = 38 dBm
Output Mismatch Stress	VSWR	-	10 : 1	-	Ψ	No damage at all phase angles, V <sub>DD</sub> = 50 V, I <sub>DQ</sub> = 10 mA, P <sub>IN</sub> = 38 dBm

Note<sup>1</sup>: Measured in CGHV40100F-AMP2 Application Circuit

### Typical Performance in Application Circuit CGHV40100F-AMP2

**Figure 6. Output Power, Efficiency, and Gain vs. Frequency of the CGHV40100F Measured in Demonstration Amplifier Circuit CGHV40100F-AMP2**  
**V<sub>DD</sub> = 50 V, I<sub>DQ</sub> = 10 mA, Pulse Width = 100 μS, Duty Cycle = 10%**

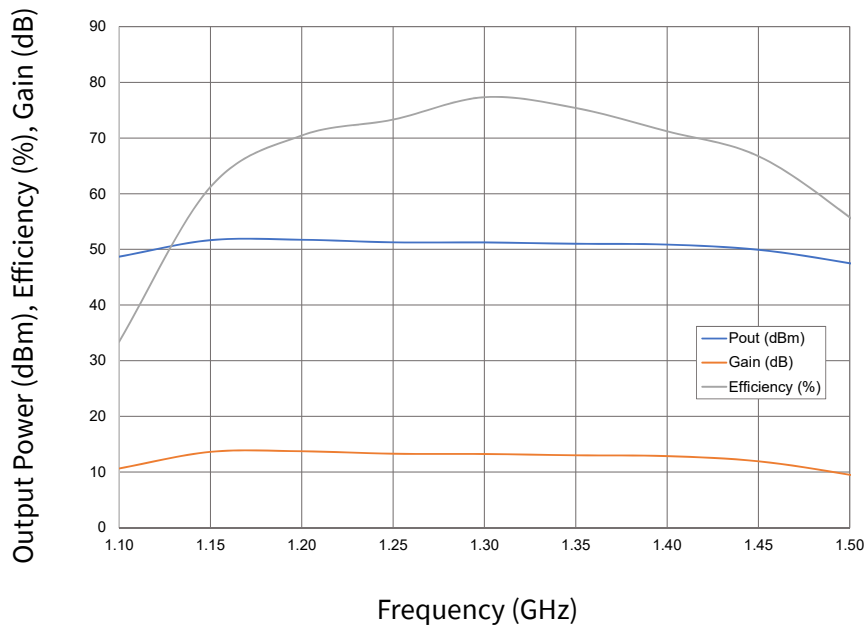





### CGHV40100F-AMP2 Demonstration Amplifier Circuit Schematic

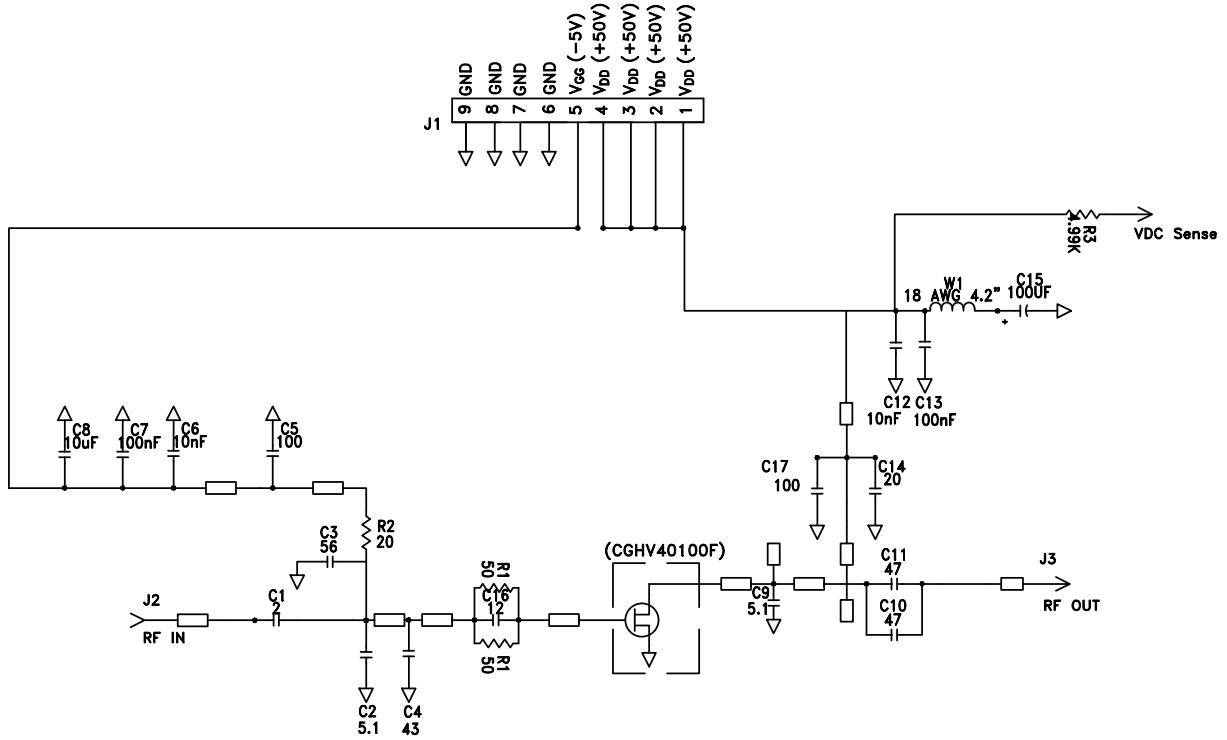

### CGHV40100F-AMP2 Demonstration Amplifier Circuit Outline

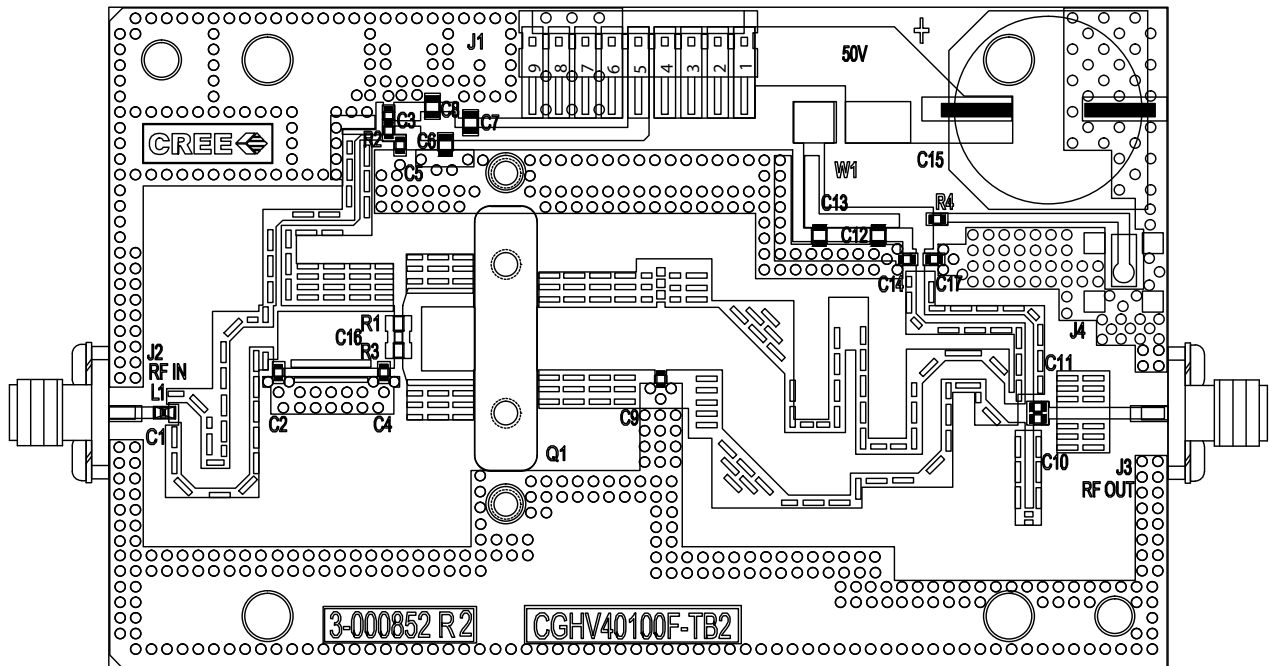

**CGHV40100F-AMP2 Bill of Materials**

Designator	Description	Qty
C1	CAP, 2.0pF, +/-0.1pF, 0603, ATC	1
R2	RES, 1/16W, 0603, 1%, 20 Ohms	1
R4	RES,1/16W,0603,1%,4.99K OHMS	1
R1, R3	RES, AIN, 50.0 OHM, +/- 5%, 0505, PtAg TERMINATION	1
C8	CAP, 10UF, 10%, 1206, 16V	1
C1, C5, C17	CAP, 100.0pF, +/-5%, 0603, ATC	3
C16	CAP, 12.0pF, +/-5%, 0603, ATC600	1
C14	CAP, 20.0pF, +/-5%, 0603, ATC600S	1
C4	CAP, 43pF,+/-5%pF, 0603, ATC	1
C10, C11	CAP, 47pF,+/-5%pF, 0603, ATC	2
C3	CAP, 56PF +/- 5%, 0603 , ATC600S	1
C2, C9	CAP, 5.1PF, +/-0.05 PF, 0603, 600S	2
C6, C12	CAP,0805,100V,TEMP STBL,1000PF	2
C7, C13	CAP, 10000PF, +/-10%, 0805, X7R, 100V, TEMP STBL	2
-	PCB, RO4350, 0.020 THK, CGHV40100F-TB2 1.2-1.4GHz RADAR	1
-	BASEPLATE, AL, 4.00 X 2.50 X 0.49 FOR THRU HOLE CAPACITORS	1
-	2-56 SOC HD SCREW 1/4 SS	4
-	#2 SPLIT LOCKWASHER SS	4
J2, J3	CONN, SMA, PANEL MOUNT JACK, FLANGE, 4-HOLE, BLUNT POST	2
J4	CONN, SMB, STRAIGHT JACK RECEPTACLE, SMT, 50 OHM, Au PLATED	1
J1	HEADER RT>PLZ .1CEN LK 9POS	1
W1	WIRE, BLACK, 18 AWG, EXTRUDED TFE TEFLON	1
L1	INDUCTOR,CHIP,2.2nH,0603 SMT	1
C2	CAP, 6.8pF, +/- 0.25 pF, 0603, ATC	1
C15	CAP, 100uF, +/-20%, 100V, ALUM ELEC	1
Q1	Transistor CGHV40100F	1

### Source and Load Impedances

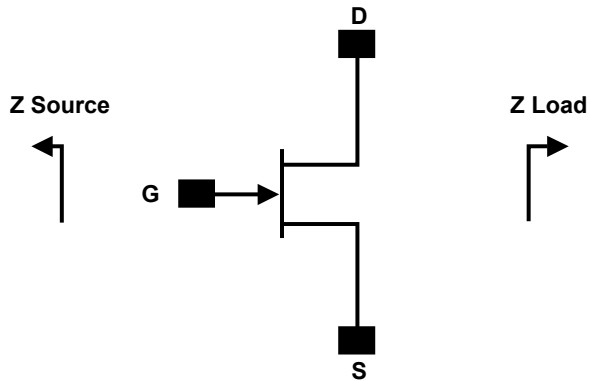

Frequency (MHz)	Z Source	Z Load
500	0.43 + j5.25	8.83 + j0.85
750	0.40 + j2.62	10.78 + j2.50
1000	0.30 + j1.31	9.06 + 4.23
1250	0.30 + j0.44	7.40 + j3.85
1500	0.30 - j0.44	6.39 + j3.44
1750	0.25 - j0.87	4.41 + j3.03
2000	0.25 - j1.31	3.68 + j2.17
2250	0.25 - j2.18	3.42 + j2.17
2500	0.26 - j2.62	2.65 + j1.74

Note 1.  $V_{DD} = 50\text{ V}$ ,  $I_{DQ} = 600\text{ mA}$  in the 440193 package  
 Note 2. Optimized for power gain,  $P_{SAT}$  and PAE

### Electrostatic Discharge (ESD) Classifications

Parameter	Symbol	Class	Test Methodology
Human Body Model	HBM	1A (> 250 V)	JEDEC JESD22 A114-D
Charge Device Model	CDM	2 (125 V to 250 V)	JEDEC JESD22 C101-C

**Product Dimensions CGHV40100F (Package Type — 440193)**

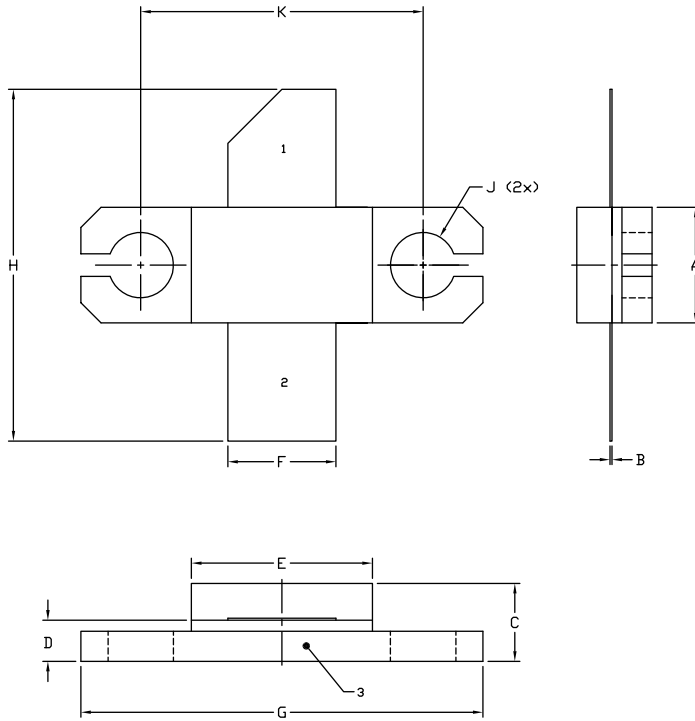

- NOTES:
1. DIMENSIONING AND TOLERANCING PER ANSI Y14.5M, 1985.
  2. CONTROLLING DIMENSION: INCH.
  3. ADHESIVE FROM LID MAY EXTEND A MAXIMUM OF 0.020" BEYOND EDGE OF LID.
  4. LID MAY BE MISALIGNED TO THE BODY OF THE PACKAGE BY A MAXIMUM OF 0.008" IN ANY DIRECTION.
  5. ALL PLATED SURFACES ARE Ni/AU

DIM	INCHES		MILLIMETERS	
	MIN	MAX	MIN	MAX
A	0.225	0.235	5.72	5.97
B	0.004	0.006	0.10	0.15
C	0.145	0.165	3.68	4.19
D	0.077	0.087	1.96	2.21
E	0.355	0.365	9.02	9.27
F	0.210	0.220	5.33	5.59
G	0.795	0.805	20.19	20.45
H	0.670	0.730	17.02	18.54
J	∅ .130		3.30	
k	0.562		14.28	

- PIN 1. GATE  
 PIN 2. DRAIN  
 PIN 3. SOURCE

**Product Dimensions CGHV40100P (Package Type — 440206)**

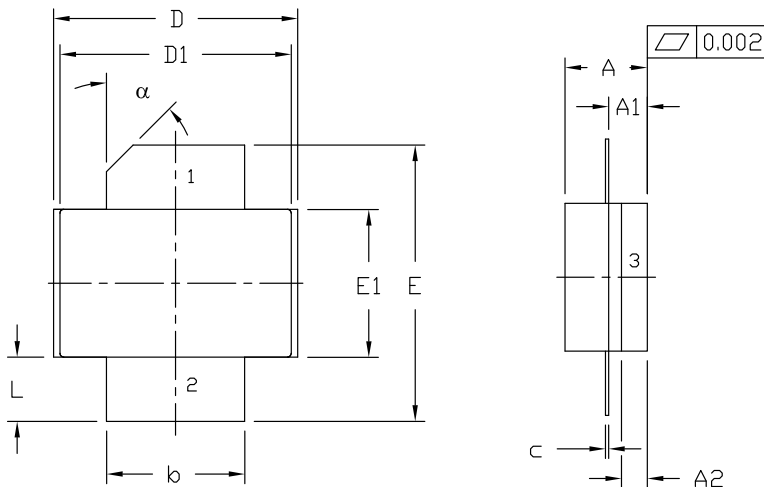

- NOTES:
1. DIMENSIONING AND TOLERANCING PER ANSI Y14.5M - 1994.
  2. CONTROLLING DIMENSION: INCH.
  3. ADHESIVE FROM LID MAY EXTEND A MAXIMUM OF 0.020" BEYOND EDGE OF LID.
  4. LID MAY BE MISALIGNED TO THE BODY OF PACKAGE BY A MAXIMUM OF 0.008" IN ANY DIRECTION.

DIM	INCHES		MILLIMETERS		NOTES
	MIN	MAX	MIN	MAX	
A	0.125	0.145	3.18	3.68	
A1	0.057	0.067	1.45	1.70	
A2	0.035	0.045	0.89	1.14	
b	0.210	0.220	5.33	5.59	2x
c	0.004	0.006	0.10	0.15	2x
D	0.375	0.385	9.53	9.78	
D1	0.355	0.365	9.02	9.27	
E	0.400	0.460	10.16	11.68	
E1	0.225	0.235	5.72	5.97	
L	0.085	0.115	2.16	2.92	2x
α	45°	REF	45°	REF	

- PIN 1. GATE  
 PIN 2. DRAIN  
 PIN 3. SOURCE

### CGHV40100 Power Dissipation De-rating Curve

**Figure 7. Transient Power Dissipation De-Rating Curve**

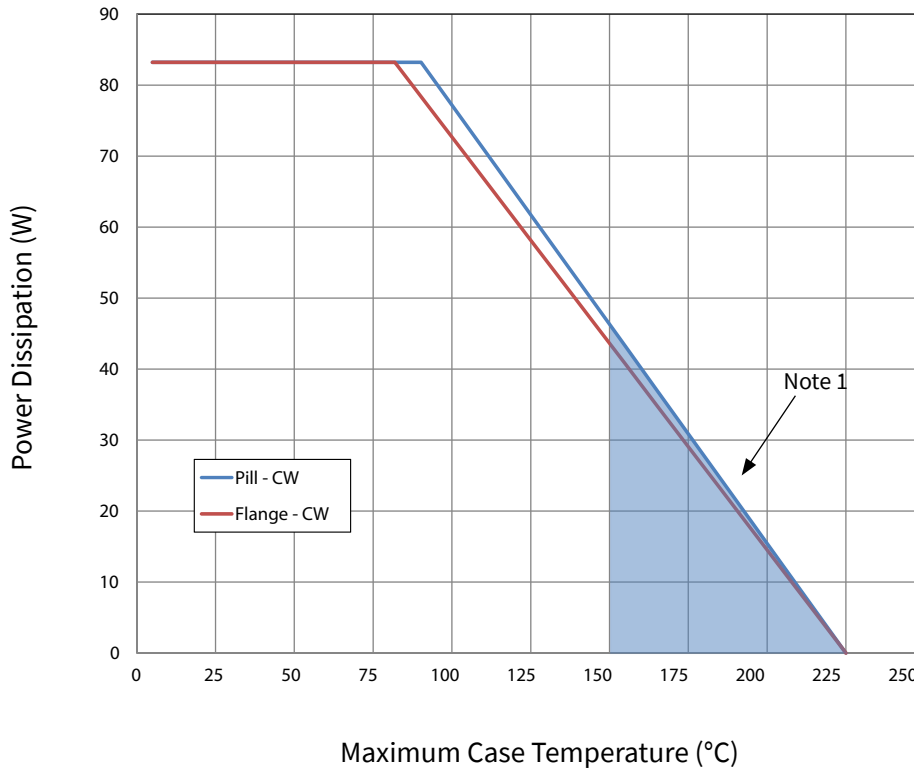

Note 1. Area exceeds Maximum Case Temperature (See Page 2).



### CGHV40100F

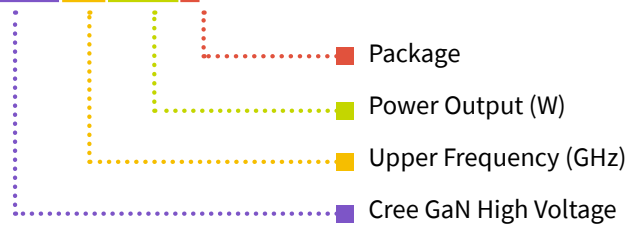

**Table 1.**

Parameter	Value	Units
Upper Frequency <sup>1</sup>	4.0	GHz
Power Output	100	W
Package	Flange	-



Note1: Alpha characters used in frequency code indicate a value greater than 9.9 GHz. See Table 2 for value.

**Table 2.**

Character Code	Code Value
A	0
B	1
C	2
D	3
E	4
F	5
G	6
H	7
J	8
K	9
Examples:	1A = 10.0 GHz 2H = 27.0 GHz

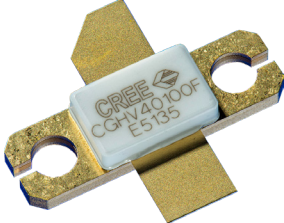

**Product Ordering Information**

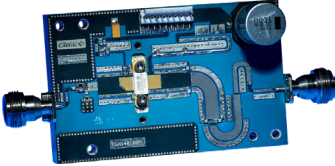
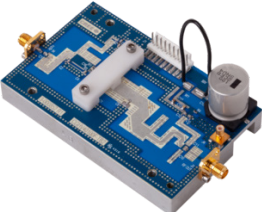
Order Number	Description	Unit of Measure	Image
CGHV40100F	GaN HEMT	Each	
CGHV40100P	GaN HEMT	Each	
CGHV40100F-AMP	Test board with GaN HEMT (CGHV40100F) installed, operating from 0.5 - 2.5 GHz for communications or ISM applications.	Each	
CGHV40100F-AMP2	Test board with GaN HEMT (CGHV40100F) installed, operating from 1.2 - 1.4 GHz for L-Band Radar.		



For more information, please contact:

4600 Silicon Drive  
Durham, North Carolina, USA 27703  
[www.wolfspeed.com/RF](http://www.wolfspeed.com/RF)

Sales Contact  
[RFSales@cree.com](mailto:RFSales@cree.com)

## Notes

---

### Disclaimer

Specifications are subject to change without notice. Cree, Inc. believes the information contained within this data sheet to be accurate and reliable. However, no responsibility is assumed by Cree for any infringement of patents or other rights of third parties which may result from its use. No license is granted by implication or otherwise under any patent or patent rights of Cree. Cree makes no warranty, representation or guarantee regarding the suitability of its products for any particular purpose. “Typical” parameters are the average values expected by Cree in large quantities and are provided for information purposes only. These values can and do vary in different applications and actual performance can vary over time. All operating parameters should be validated by customer’s technical experts for each application. Cree products are not designed, intended or authorized for use as components in applications intended for surgical implant into the body or to support or sustain life, in applications in which the failure of the Cree product could result in personal injury or death or in applications for planning, construction, maintenance or direct operation of a nuclear facility.



## X-ON Electronics

Largest Supplier of Electrical and Electronic Components

*Click to view similar products for [RF Development Tools](#) category:*

*Click to view products by [Wolfspeed](#) manufacturer:*

Other Similar products are found below :

[MAAM-011117](#) [MAAP-015036-DIEEV2](#) [EV1HMC1113LP5](#) [EV1HMC6146BLC5A](#) [EV1HMC637ALP5](#) [EVAL-ADG919EBZ](#) [ADL5363-EVALZ](#) [LMV228SDEVAL](#) [SKYA21001-EVB](#) [SMP1331-085-EVB](#) [EV1HMC618ALP3](#) [EVAL01-HMC1041LC4](#) [MAAL-011111-000SMB](#)  
[MAAM-009633-001SMB](#) [107712-HMC369LP3](#) [107780-HMC322ALP4](#) [SP000416870](#) [EV1HMC470ALP3](#) [EV1HMC520ALC4](#)  
[EV1HMC244AG16](#) [MAX2614EVKIT#](#) [124694-HMC742ALP5](#) [SC20ASATEA-8GB-STD](#) [MAX2837EVKIT+](#) [MAX2612EVKIT#](#)  
[MAX2692EVKIT#](#) [SKY12343-364LF-EVB](#) [108703-HMC452QS16G](#) [EV1HMC863ALC4](#) [EV1HMC427ALP3E](#) [119197-HMC658LP2](#)  
[EV1HMC647ALP6](#) [ADL5725-EVALZ](#) [106815-HMC441LM1](#) [EV1HMC1018ALP4](#) [UXN14M9PE](#) [MAX2016EVKIT](#) [EV1HMC939ALP4](#)  
[MAX2410EVKIT](#) [MAX2204EVKIT+](#) [EV1HMC8073LP3D](#) [SIMSA868-DKL](#) [SIMSA868C-DKL](#) [SKY65806-636EK1](#) [SKY68020-11EK1](#)  
[SKY67159-396EK1](#) [SKY66181-11-EK1](#) [SKY65804-696EK1](#) [SKY13396-397LF-EVB](#) [SKY13380-350LF-EVB](#)