



KIT-CRD-8FF65P (650V)
KIT-CRD-8FF90P (900V)
D2 Pack Evaluation Kit

D2 Pack Evaluation Kit

- ❑ Evaluate SiC MOSFET switching performance. This board is an ideal means to characterize E_{ON} and E_{OFF} losses in SiC MOSFETs.
- ❑ Evaluate SiC MOSFET steady state performance. The heatsinks are predrilled with wells for thermocouples so the heatsink temperature just underneath the MOSFET's case can be measured.
- ❑ Demonstrate the AlN inlay PCB technology for thermal management of surface mount power devices.
- ❑ Gate drive reference design and PCB layout example for a D2PACK package MOSFET.
- ❑ Can easily be configured to run in many common topologies (synchronous buck, synchronous boost, asynchronous buck, asynchronous boost, phase leg, etc)



Key Hardware Features

- ❑ PC board contains two aluminum nitride inserts which provide both electrical isolation for the MOSFETs, and heat transfer of the MOSFET losses from the top of the board to the heatsink on the bottom side of the board.
- ❑ Features two ADuM4121 MOSFET drivers which include active miller clamping and 2A ($<2\Omega R_{\text{DS(ON)}}$) peak output current for lower switching losses.
- ❑ SMA connectors located close to each MOSFET allowing for clean V_{GS} waveforms
- ❑ Test loops placed near each MOSFET allowing for easy V_{DS} measurements
- ❑ Provisions for adding a low inductance current monitoring device.
- ❑ Heatsinks are predrilled with wells for thermocouples so the heatsink temperature just underneath the MOSFET's case can be measured.

Kit Contents

- ❑ Includes pc board containing two C3M MOSFETs utilizing aluminum nitride insert for thermal dissipation and electrical isolation.
- ❑ Includes custom heatsink, fan, fan guard, and thermal pads.
- ❑ Includes two SMA to BNC adapters for monitoring V_{GS} **
- ❑ Includes all hardware, standoffs

** Measuring top device requires isolated scope channel or isolated probe



Board Electrical Specifications

Items	Values	
KIT VERSION	CRD-8FF65P (650V)	CRD-8FF90P (900V)
Included MOSFETs	C3M0060065J	C3M0065090J
MOSFET specs	650V, 60mohm	900V, 65mohm
Max DC Bus Voltage	450V	600V
VCC (Logic Power)	15VDC	
VCC Input Current (standby)	40mA (typical)	

Thermal Management

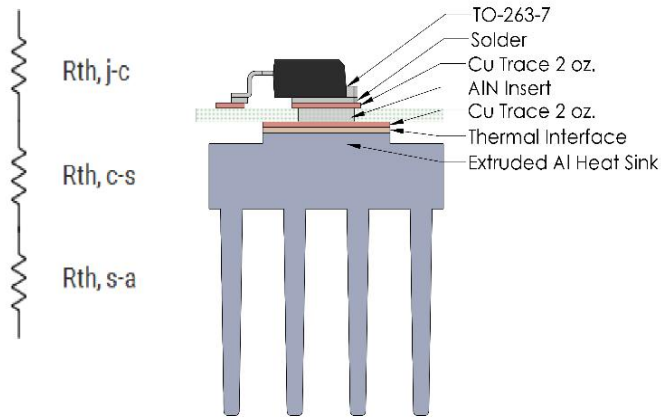

Parameter	Value	Note
$R_{th,j-c}$ ($^{\circ}\text{C/W}$)	1.2 (650V kit) 1.1 (900V kit)	From datasheet
$R_{th,c-s}$ ($^{\circ}\text{C/W}$)	1.28	
$R_{th,s-a}$ ($^{\circ}\text{C/W}$)	2.60	

- ❑ Underneath each MOSFET, there is a 11mmx7mm aluminum nitride insert embedded in the pc board which transfers the heat from the top side of the pc board to the bottom side.
- ❑ Top and bottom layers of the pc board are 2oz copper with large planes connected to the drain tab of each MOSFET to help dissipate heat.

Key Component Locations

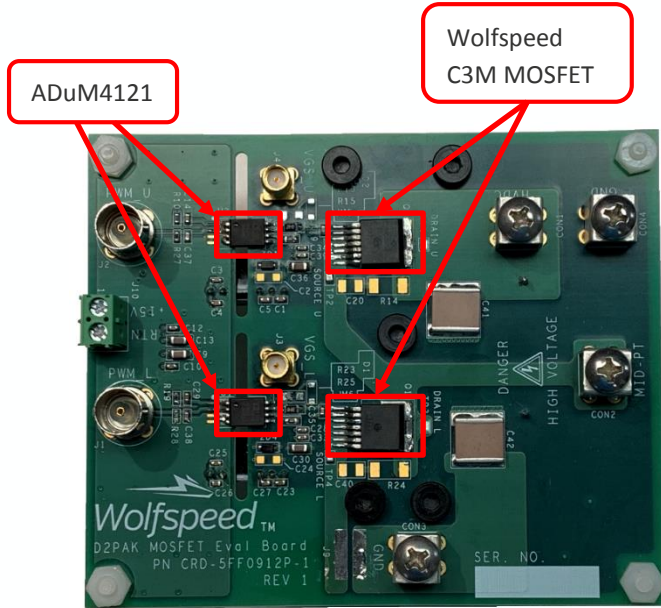

MOSFET and Gate Driver Locations

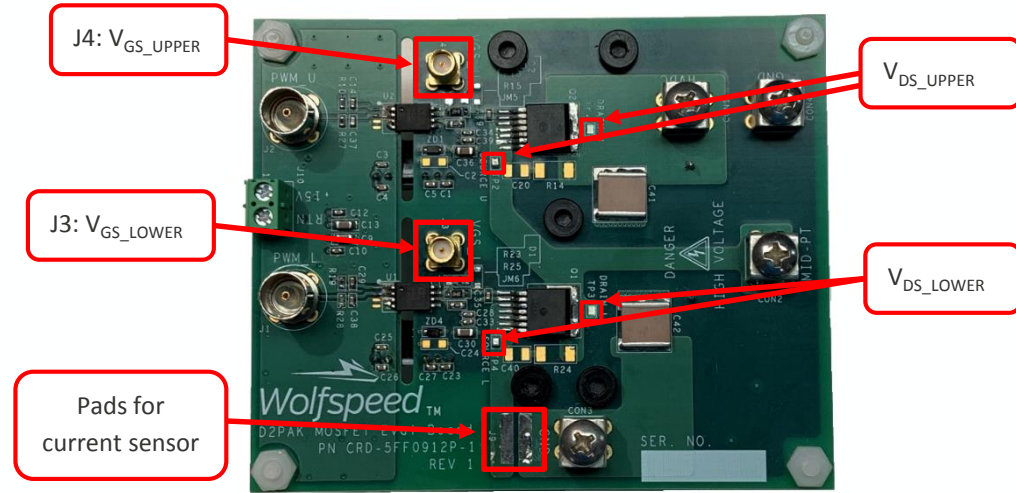

Test Point Locations

Key Component Locations (continued)

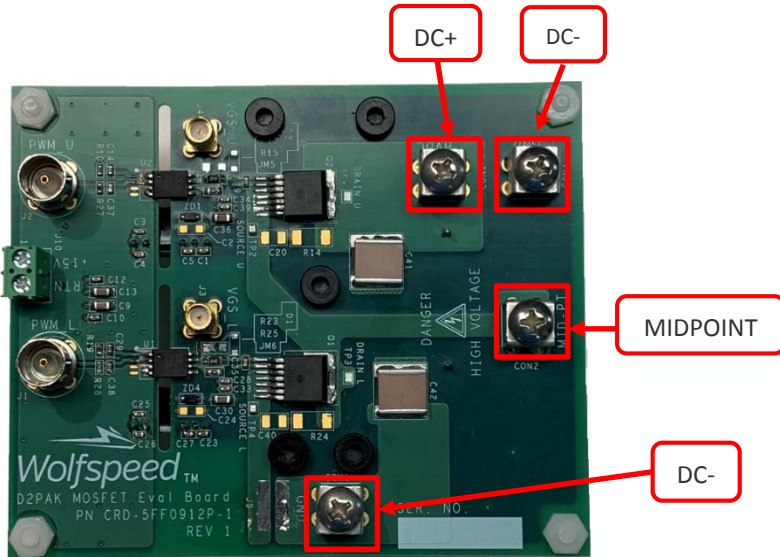

Power Terminals

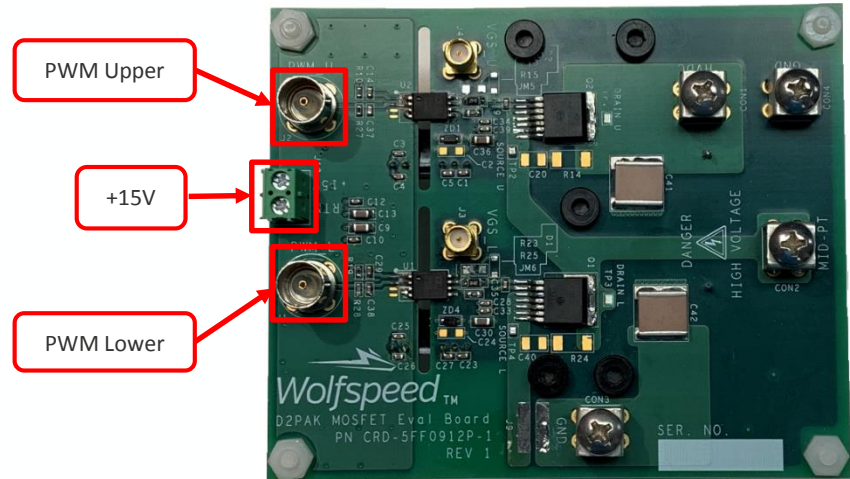

Logic and PWM Inputs

Supported Topologies

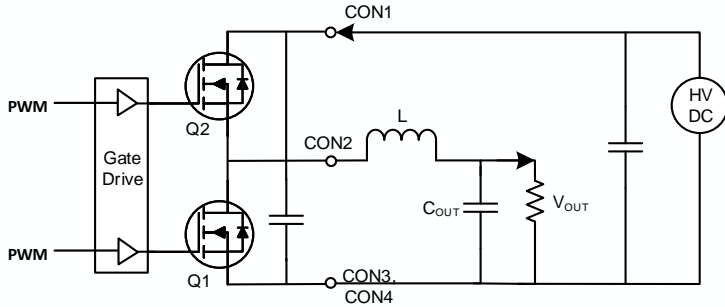

Synchronous Buck

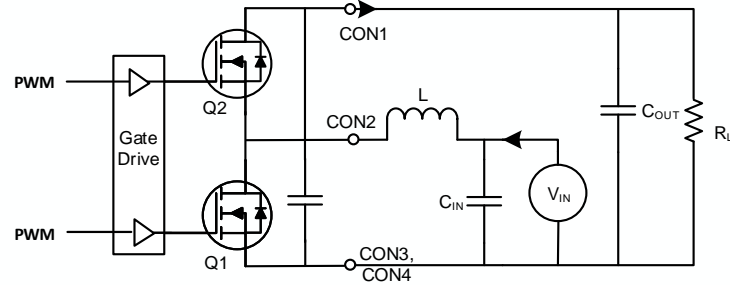

Synchronous Boost

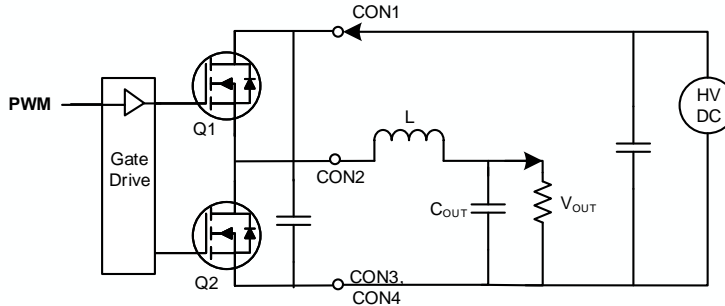

Asynchronous Buck*

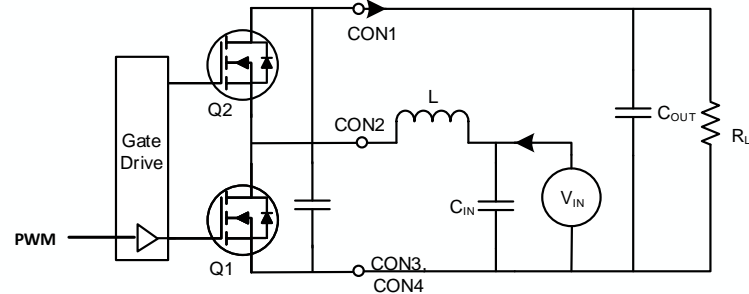

Asynchronous Boost*

*Asynchronous topologies utilize the MOSFET body diode for freewheeling.

Supported Topologies (continued)

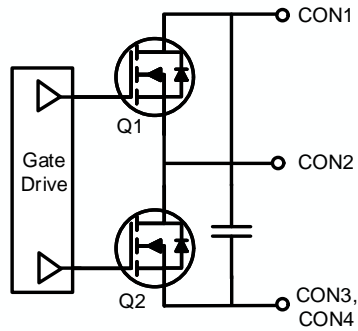

Phase Leg

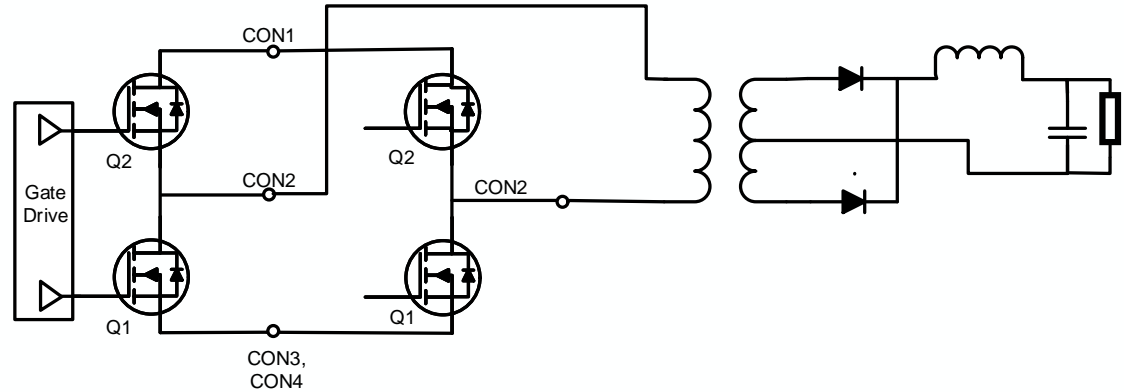

**Full Bridge DC/DC
*requires 2 kits***

Example #1: Synchronous Boost Converter

Items	Parameters
Input Voltage	200V
Output Voltage	≈385V
Output Current	11A
Output Power	4200W
Switching Frequency	100kHz
Duty Cycle	48.5%
Deadtime	200ns
Inductor	400μF
Output Capacitor	40μf
Input Capacitor	40μf

Electrical Parameters

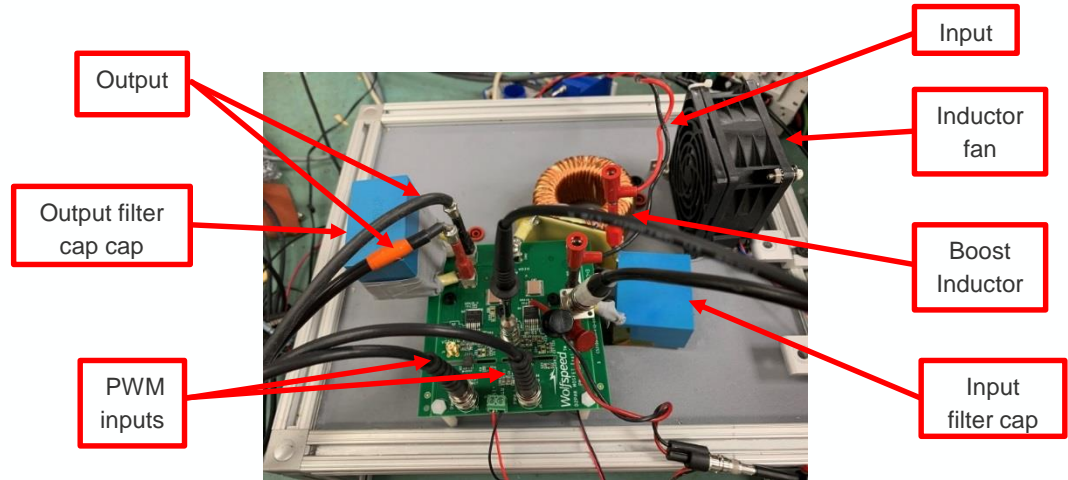

Test Setup

Synchronous Boost Converter Scope Captures

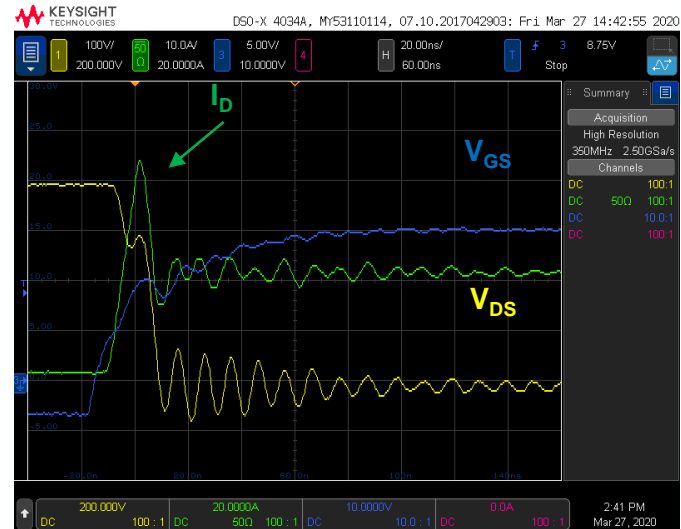
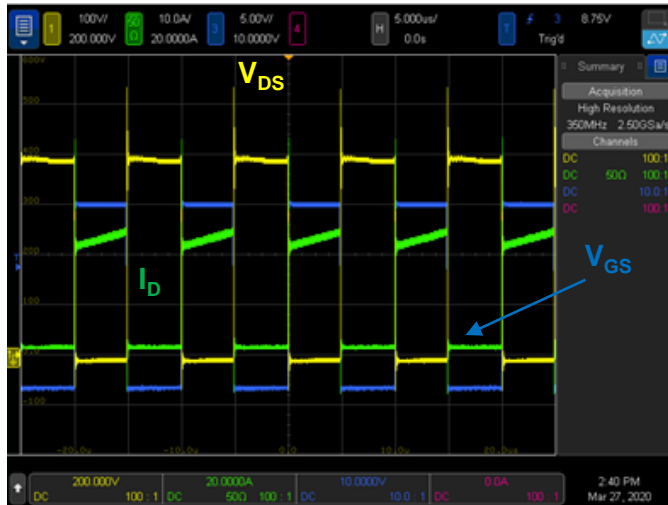

Synchronous Boost Converter Efficiency and Thermal Scan

CRD-8FF65P (650V)

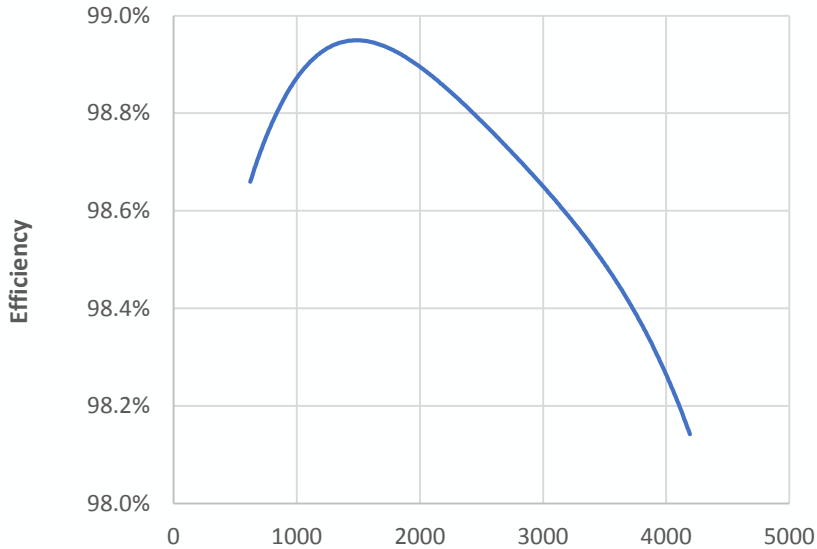

Output Power (W)

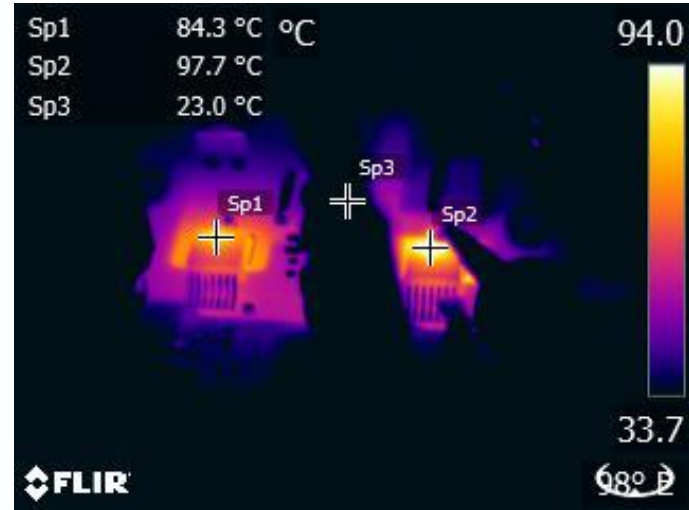

Thermal Scan at 4.3kW Output Power

Example #2: Switching Energy Measurements (Double Pulse)

- ❑ Scope probes measuring V_{DS} and V_{GS} must have minimal loop between signal and ground. BNC and SMA connections give best signal fidelity.
- ❑ The oscilloscope scope probes measuring V_{DS} and I_{DS} must be deskewed.
- ❑ Bulk capacitance may need to be added to the board to minimize DC link droop during two-pulse measurements. The amount will vary based on desired current level and pulse width.

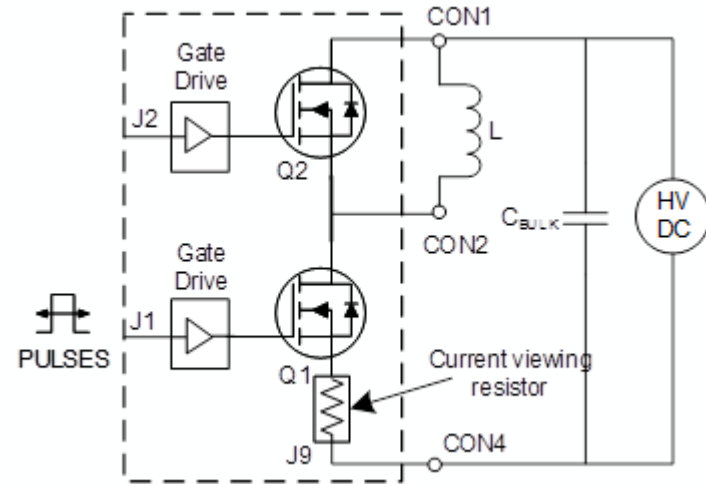

Clamped Inductive Switching Measurement Circuit

Double Pulse Measurement Setup

Air core inductor

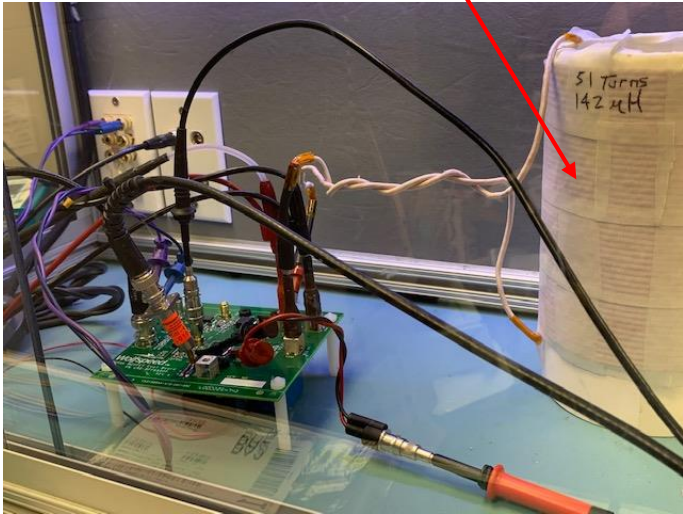

Double Pulse Measurements

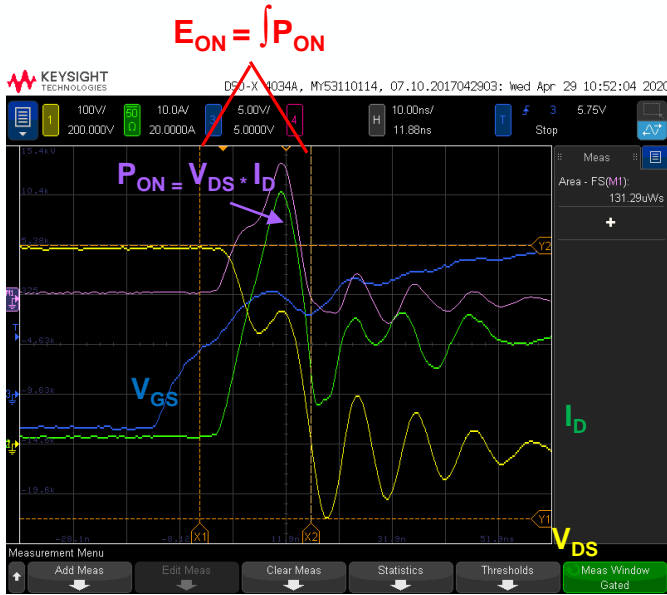

Turn-on waveforms

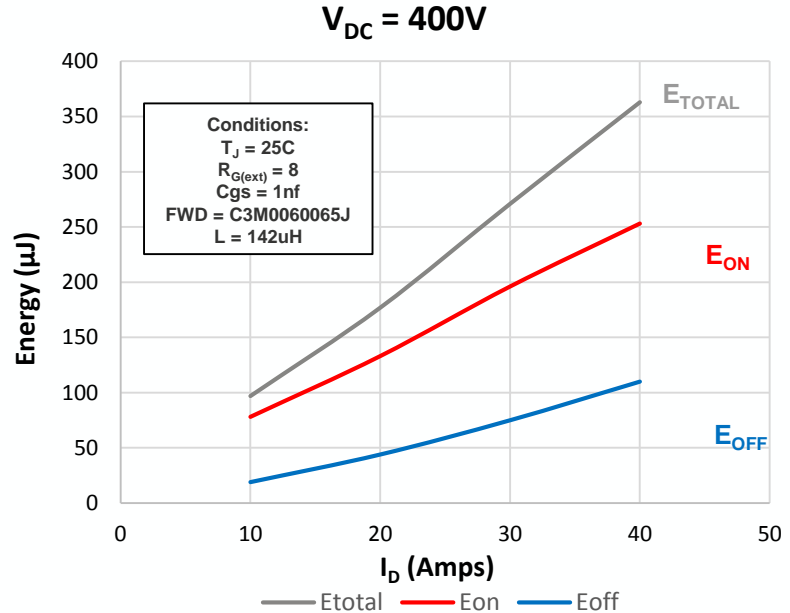

Switching Energy Curves

V_{DS} is multiplied by I_D to give the power dissipation in the MOSFET. The power waveform is integrated during the turn-on event to compute E_{ON} . This is done at various current levels to produce an E_{ON} curve. The same is done at turn-off events to produce an E_{OFF} curve.



X-ON Electronics

Largest Supplier of Electrical and Electronic Components

Click to view similar products for [Power Management IC Development Tools](#) category:

Click to view products by [Wolfspeed](#) manufacturer:

Other Similar products are found below :

[EVAL-ADM1168LQEBZ](#) [EVB-EP5348UI](#) [MIC23451-AAAYFL EV](#) [MIC5281YMME EV](#) [DA9063-EVAL](#) [ADP122-3.3-EVALZ](#) [ADP130-0.8-EVALZ](#) [ADP130-1.2-EVALZ](#) [ADP130-1.5-EVALZ](#) [ADP130-1.8-EVALZ](#) [ADP1714-3.3-EVALZ](#) [ADP1716-2.5-EVALZ](#) [ADP1740-1.5-EVALZ](#) [ADP1752-1.5-EVALZ](#) [ADP1828LC-EVALZ](#) [ADP1870-0.3-EVALZ](#) [ADP1871-0.6-EVALZ](#) [ADP1873-0.6-EVALZ](#) [ADP1874-0.3-EVALZ](#) [ADP1882-1.0-EVALZ](#) [ADP199CB-EVALZ](#) [ADP2102-1.25-EVALZ](#) [ADP2102-1.875EVALZ](#) [ADP2102-1.8-EVALZ](#) [ADP2102-2-EVALZ](#) [ADP2102-3-EVALZ](#) [ADP2102-4-EVALZ](#) [ADP2106-1.8-EVALZ](#) [ADP2147CB-110EVALZ](#) [AS3606-DB](#) [BQ24010EVM](#) [BQ24075TEVM](#) [BQ24155EVM](#) [BQ24157EVM-697](#) [BQ24160EVM-742](#) [BQ24296MEVM-655](#) [BQ25010EVM](#) [BQ3055EVM](#) [NCV891330PD50GEVB](#) [ISLUSBI2CKIT1Z](#) [LM2744EVAL](#) [LM2854EVAL](#) [LM3658SD-AEV/NOPB](#) [LM3658SDEV/NOPB](#) [LM3691TL-1.8EV/NOPB](#) [LM4510SDEV/NOPB](#) [LM5033SD-EVAL](#) [LP38512TS-1.8EV](#) [EVAL-ADM1186-1MBZ](#) [EVAL-ADM1186-2MBZ](#)