



# WS2811M

## Single line 256 Gray level 3-channel Constant current LED drive IC

### Features and Benefits

- Output port compression 12V.
- Built in stabilivolt, Only add a resistance to IC VDD feet when under 24V power supply.
- Gray level 256 can be adjusted and scan frequency not less than 400Hz/s.
- Built in signal reshaping circuit, after wave reshaping to the next driver, ensure wave-form distortion not accumulate.
- Built-in electric reset circuit and power lost reset circuit.
- Cascading port transmission signal by single line.
- Any two point the distance more than 3m transmission signal without any increase circuit.
- When the refresh rate is 30fps, cascade numbers are far more than 1024 points.
- Data transmitting at speeds of up to 800Kbps.

### Applications

- Guardrail tube series, point light display series, flexible/rigid strips series, module series applications.
- Lighting stage costumes, innovative gadgets or any other electronic products.

### General description

The WS2811-M is 3 output channels special for LED driver circuit. It internal include intelligent digital port data latch and signal reshaping amplification drive circuit. Also include a precision internal oscillator and a 12V voltage programmable constant current output drive. In the purpose of reduce power supply ripple, the 3 output channels designed to delay turn-on function.

IC use single NZR communication mode. After the chip power-on reset, the DIN port receive data from controller, the first IC collect initial 24bit data then sent to the internal data latch, the other data which reshaping by the internal signal reshaping amplification circuit sent to the next cascade IC through the DO port. After transmission for each chip, the signal to reduce 24bit. IC adopt auto reshaping transmit technology, making the chip cascade number is not limited the signal transmission, only depend on the speed of signal transmission.

The data latch of IC depend on the received 24bit data produce different duty ratio signal at OUTR, OUTG, OUTB port. All chip synchronous send the received data to each segment when the DIN port input a reset signal. It will receive new data again After the reset signal finished. Before a new reset signal received, the control signal of OUTR, OUTG, OUTB port unchanged. IC sent PWM data that received justly to OUTR, OUTG, OUTB port, after receive a low voltage reset signal the time retain over 50us.

### PIN configuration

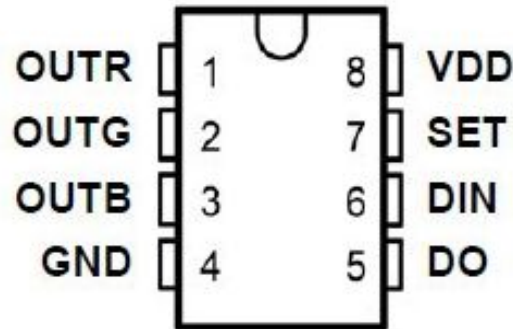

### PIN function

NO.	Symbol	Function description
1	OUTR	Output of Red PWM control
2	OUTG	Output of Green PWM control
3	OUTB	Output of Blue PWM control
4	GND	Ground
5	DOUT	Data signal cascade output
6	DIN	Data signal input
7	SET	Set work mode of IC as low speed model(connect VDD) or high speed model(vacant)
8	VDD	Power supply voltage

### Absolute Maximum Ratings

Parameter	Symbol	Ratings	Unit
Power supply Voltage	V <sub>DD</sub>	+6.0~+7.0	V
Output Voltage	V <sub>OUT</sub>	12	V
Input Voltage	V <sub>I</sub>	-0.5~V <sub>DD</sub> +0.5	V
Operation Junction Temperature	T <sub>opt</sub>	-25~+85	°C
Storage Temperature Range	T <sub>stg</sub>	-55~+150	°C

Note: If the voltage on the pins exceeds the maximum ratings may cause permanent damage to the device.



# WS2811M

## Single line 256 Gray level 3-channel Constant current LED drive IC

**Electrical Characteristics** ( $T_A=-20\sim+70^{\circ}\text{C}$ ,  $V_{DD}=4.5\sim 5.5\text{V}$ ,  $V_{SS}=0\text{V}$ , unless otherwise specified)

Parameter	Smybol	conditions	Min	Tpy	Max	Unit
Low voltage output current	$I_{OL}$	ROUT	—	18.5	—	mA
	$I_{dout}$	$V_O=0.4\text{V}$ , $D_{OUT}$	10	—	—	mA
Input current	$I_I$	$V_I=V_{DD}/V_{SS}$	—	—	$\pm 1$	$\mu\text{A}$
Input voltage level	$V_{IH}$	$D_{IN}$ , SET	$0.7V_{DD}$	—	—	V
	$V_{IL}$	$D_{IN}$ , SET	—	—	$0.3 V_{DD}$	V
Hysteresis voltage	$V_H$	$D_{IN}$ , SET	—	0.35	—	V

**Switching characteristics** ( $T_A=-20\sim+70^{\circ}\text{C}$ ,  $V_{DD}=4.5\sim 5.5\text{V}$ ,  $V_{SS}=0\text{V}$ , unless otherwise specified)

Parameter	Symbol	Condition	Min	Tpy	Max	Unit
Operation frequency	$F_{osc1}$	—	—	400	—	KHz
	$F_{osc2}$	—	—	800	—	KHz
Transmission delay time	$t_{PLZ}$	$CL=15\text{pF}$ , $D_{IN}\rightarrow D_{OUT}$ , $RL=10\text{K}\Omega$	—	—	300	ns
Fall time	$t_{THZ}$	$CL=300\text{pF}$ , $OUTR/\text{OUTG}/\text{OUTB}$	—	—	120	$\mu\text{s}$
Data transmission rate	$F_{MAX}$	Duty ratio 50%	400	—	—	Kbps
Input capacity	$C_I$	—	—	—	15	pF

### High Speed Mode Time

T0H	0 code, high voltage time	$0.4 \mu\text{s}$	$\pm 150\text{ns}$
T1H	1 code, high voltage time	$0.85 \mu\text{s}$	$\pm 150\text{ns}$
T0L	0 code, low voltage time	$0.85 \mu\text{s}$	$\pm 150\text{ns}$
T1L	1 code, low voltage time	$0.4 \mu\text{s}$	$\pm 150\text{ns}$
RES	low voltage time	$50\mu\text{s}$ or more	

### Sequence Chart

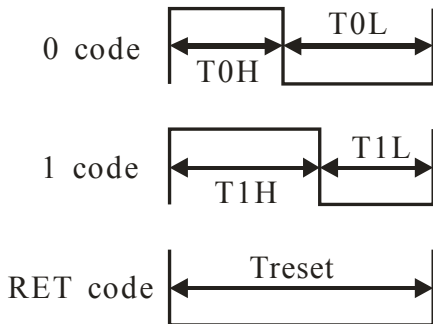

### Cascade Method

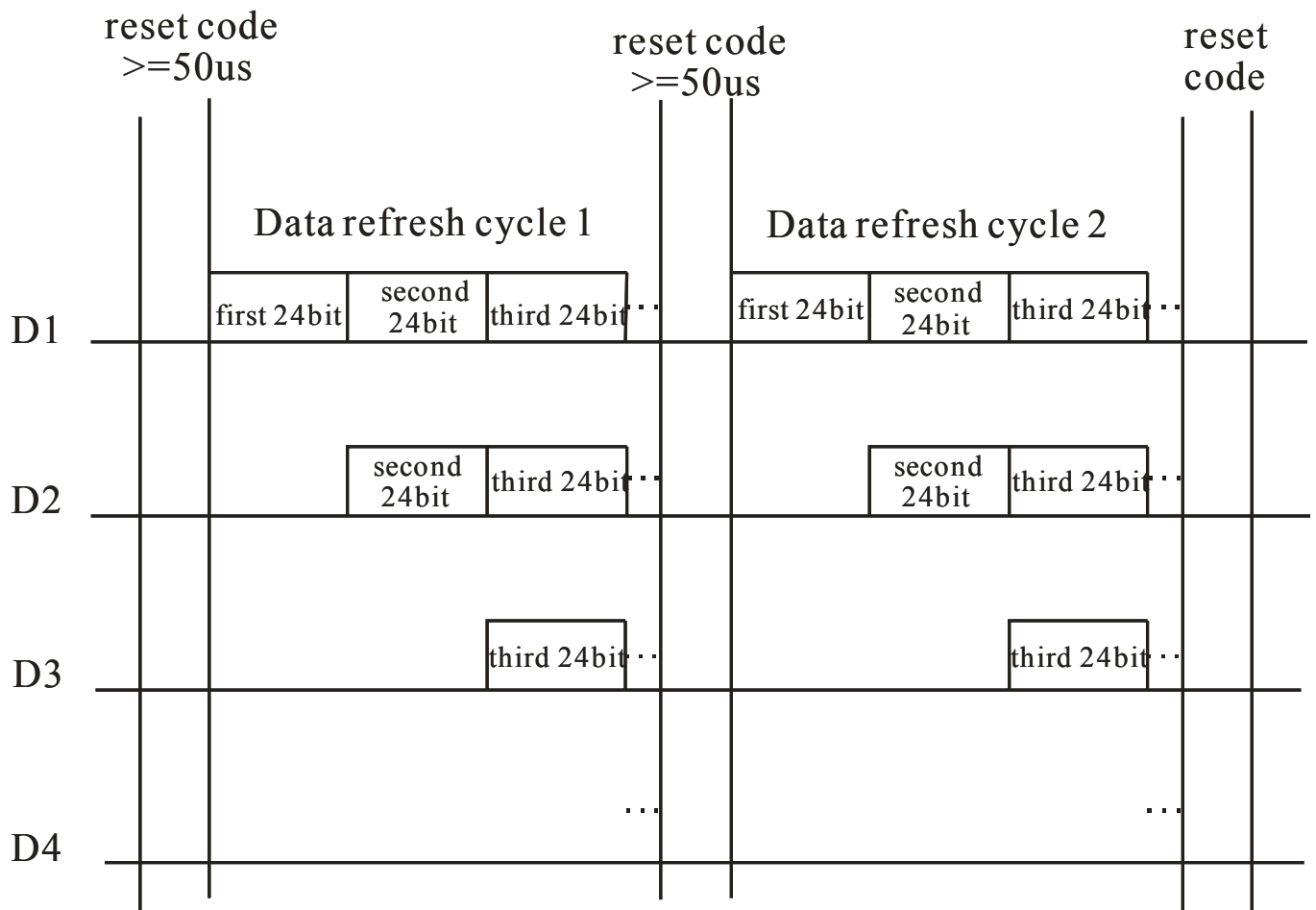
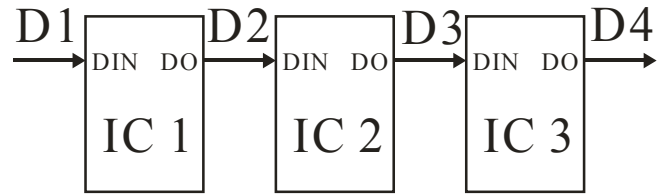

### Data transmission method

Note: The data of D1 is send by MCU, and D2, D3, D4 through IC internal reshaping amplification to transmit.

### Composition of 24bit data

R7	R6	R5	R4	R3	R2	R1	R0	G7	G6	G5	G4	G3	G2	G1	G0	B7	B6	B5	B4	B3	B2	B1	B0
----	----	----	----	----	----	----	----	----	----	----	----	----	----	----	----	----	----	----	----	----	----	----	----

Note: Follow the order of RGB to sent data and the high bit sent at first.

### Typical application circuit

#### 1. Power supply is 5V with 1 LED and constant current (18.5mA) driving

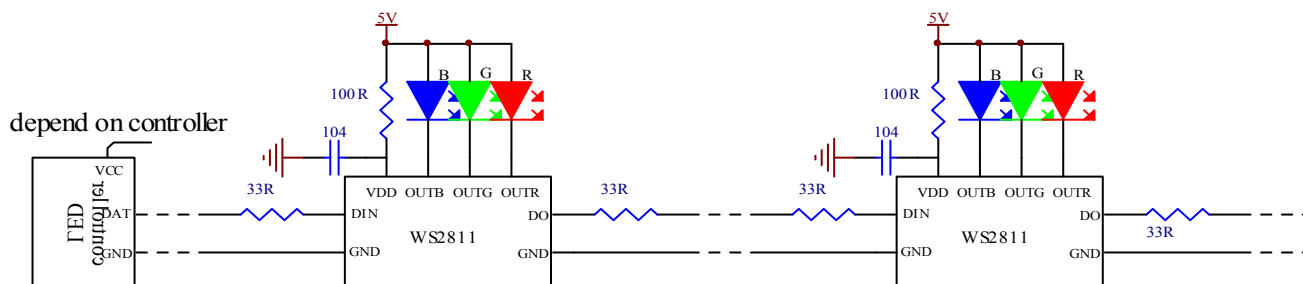

**Fig 1**

This driving mode use constant current output, the advantage of is the LED can retain lumens and color temperature when the power supply lessen. We require, in order to prevent power spikes phenomenon and power reverse polarity, series a not more than 100ohm resistor at the power supply pin(VDD). The capacitance 104 as bypass capacitor. To prevent the reflection and hot-swap protection, we suggest to connect a 33ohm resistor at the data input or output port for impedance.

#### 2. Power supply is 12V with 3 LED and constant current(18.5mA) driving

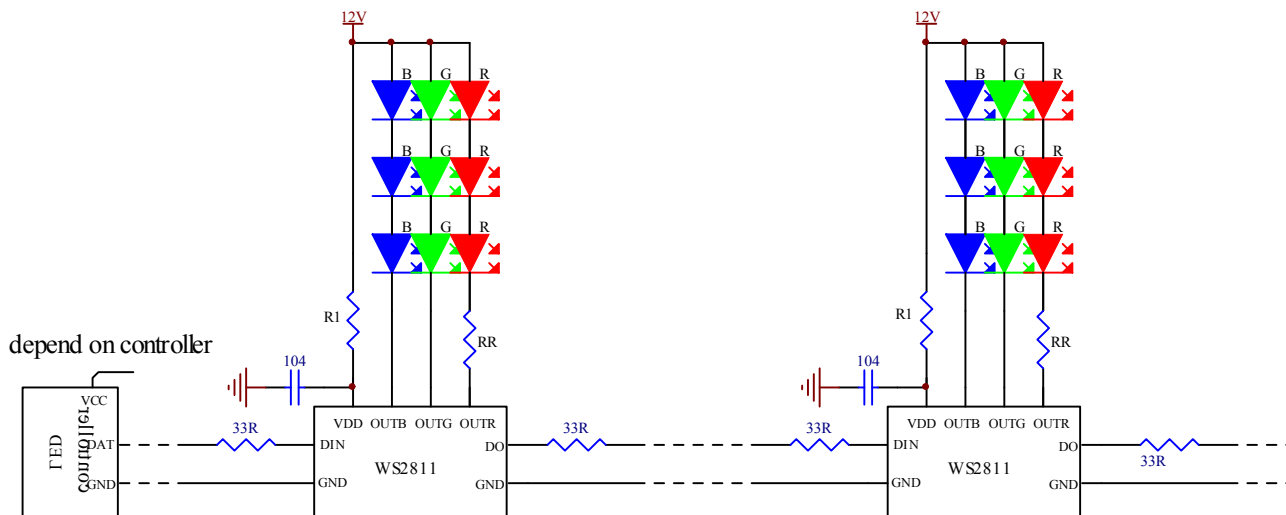

**Fig 2**

The same as the front mode, it is also use constant current output. In this circuit, R1 is used as the IC internal LDO divider resistance and the value is 2.7K. The capacitance 104 as bypass capacitor. To prevent the reflection and hot-swap protection, we suggest to connect a 33ohm resistor at the data input or output port for impedance. At the OUTR port we should add a divider resistance RR. The value of RR can be derived by the following equation:

$$RR = \frac{12 - 3V_{LEDR}}{18.5} K\Omega$$

$V_{LEDR}$  is the red LED forward conduction voltage drop.

### 3. Expansion Current Circuit

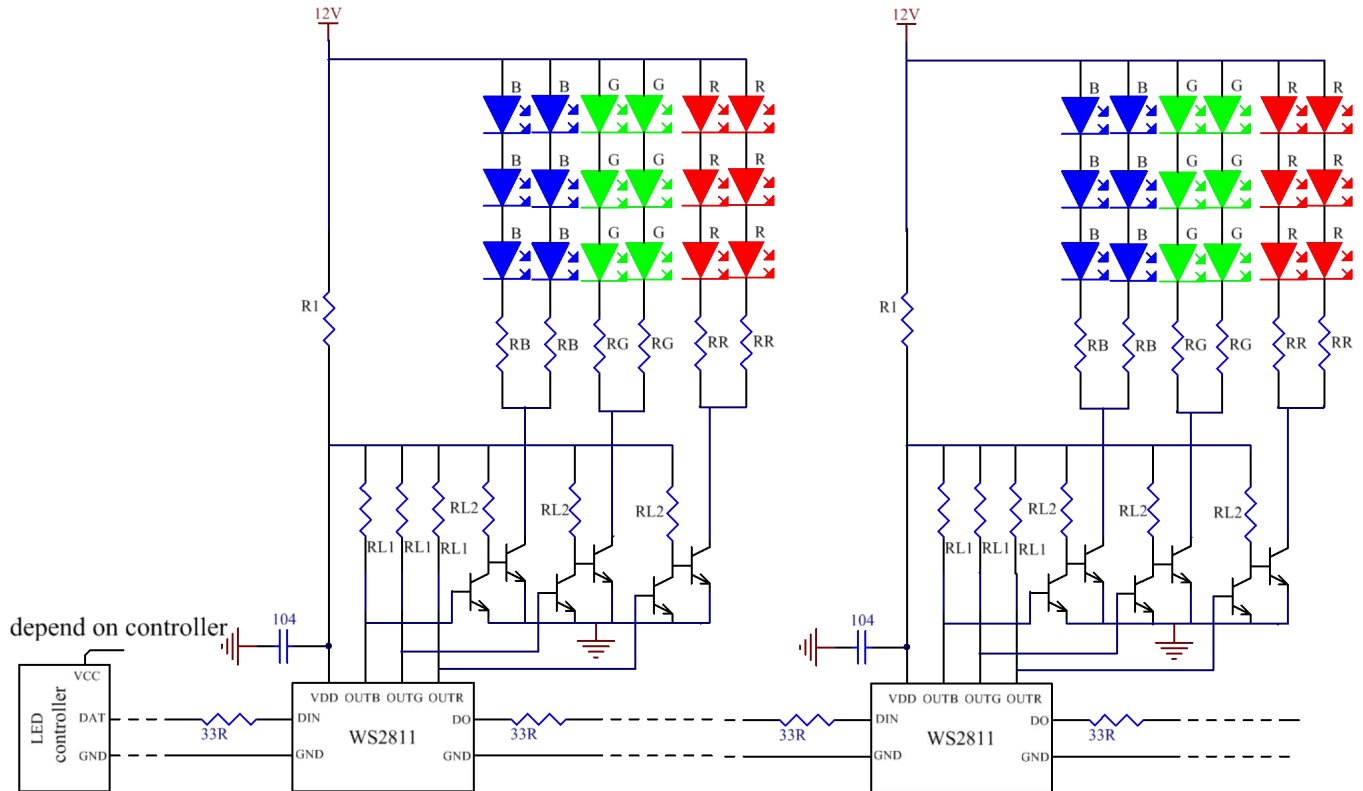

Notes: As the above picture shows, the current expanded with using the external transistor. The brightness of RGB pins are adjusted by PWM wave, so it causes PMW wave phased once using single transistor, as a result, control data and conventional control data are not compatible. Since the expansion circuit gets power from WS2811 Power-pins, and RL1,RL2 should be kept in maximum value in the premise of transistor saturation conduction, which ensures the normal power supply of WS2811 Power-pins (RL1=470KΩ & RL2=10KΩ recommended). The value of RB, RG and RR are related to the size of the current of the LED bunch, and these calculated as below computational formula.

$$RB = \frac{12 - 3V_{LED}}{I_x} \quad RG = \frac{12 - 3V_{LED}}{I_x} \quad RR = \frac{12 - 3V_{LED}}{I_x}$$

I<sub>x</sub> said as the current size of the LED branch being set.

### Package Information

#### MSOP8 Package

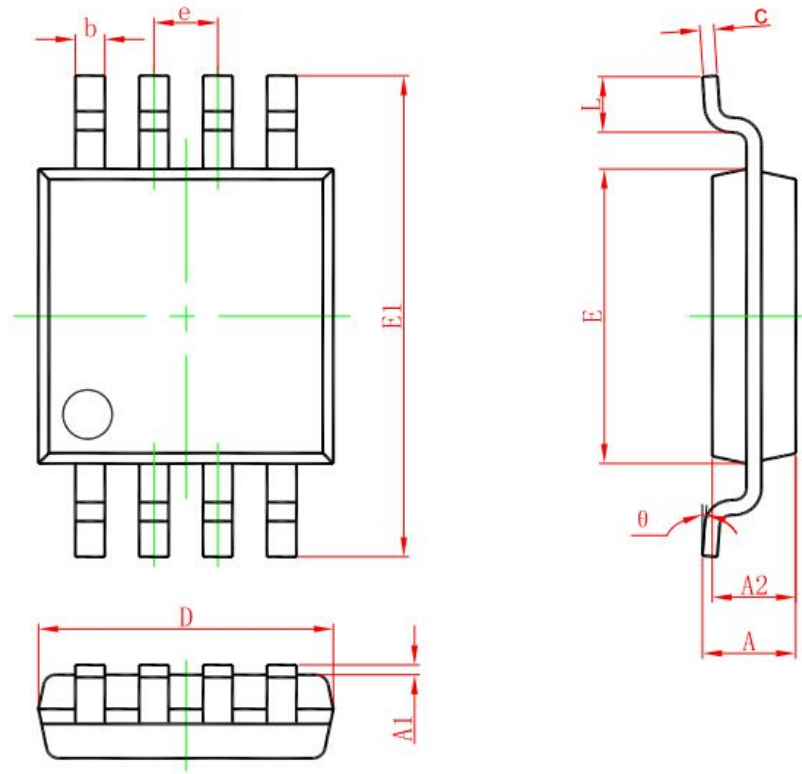

Symbol	Dimensions In Millimeters		Dimensions In Inches	
	Min	Max	Min	Max
A	0.820	1.100	0.032	0.043
A1	0.020	0.150	0.001	0.006
A2	0.750	0.950	0.030	0.037
b	0.250	0.380	0.010	0.015
c	0.090	0.230	0.004	0.009
D	2.900	3.100	0.114	0.122
e	0.650(BSC)		0.026(BSC)	
E	2.900	3.100	0.114	0.122
E1	4.750	5.050	0.187	0.199
L	0.400	0.800	0.016	0.031
θ	0°	6°	0°	6°

## X-ON Electronics

Largest Supplier of Electrical and Electronic Components

*Click to view similar products for [LED Display Drivers](#) category:*

*Click to view products by [Worldsemi](#) manufacturer:*

Other Similar products are found below :

[STP16DP05PTR](#) [MP3370GN-Z](#) [ISL97631IHTZ-T7A](#) [ISL97632IRT26Z-T](#) [LV5026MC-AH](#) [IK62083DWT](#) [OB3655TAP-H](#) [OB3399PAP](#)  
[AW36514FCR](#) [AW36428FCR](#) [KAQW214A TL](#) [TM1629\(TA2009B\)](#) [WS2814F](#) [XB402U-L27](#) [HT16K33A-20SOP](#) [HT16D33A-28SSOP](#)  
[TM1628E](#) [TM512AE0](#) [TM512AD](#) [TM0822B](#) [SY7310AADC](#) [SY58863FAC](#) [SY5863AJAC](#) [FM4115K.](#) [TM1638N-SOP28-TA1319B](#)  
[SPL5013CNI-TRG](#) [AW21024QNR](#) [AW36423FCR](#) [AW36515FCR](#) [AW99703CSR](#) [AW21036QNR](#) [AW21009QNR](#) [AW20108QNR](#)  
[AW2016AQNR](#) [AW9967DNR](#) [AW9106CQNR](#) [PT4115BE89E](#) [CC1108ST](#) [CC1109](#) [SD6800BCTR](#) [SDH7612DH](#) [HT16D35A-48LQFP-EP](#)  
[HT1635C-64LQFP-7\\*7](#) [HT16K33A-28SOP](#) [HT16D31A-16NSOP-EP](#) [TLD5099EP](#) [BCR 431U](#) [IS32FL3740-ZLA3-TR](#)  
[PAM2804AAB010\(MS\)](#) [OB3379ZCPA-D](#)