

PROGRAMMABLE PRECISION REFERENCES

The TL431 is three-terminal adjustable shunt regulator with specified thermal stability.

The output voltage may be set to any value between V_{REF} (Approx. 2.5V) and 36V with two external resistors. This device has a typical output impedance of 0.2Ω .

Active output circuitry provides a very sharp turn-on characteristic, making this device excellent replacement for zener diodes in many applications.

FEATURES

- Equivalent Full Range Temperature Coefficient 50PPM/°C
- Temperature Compensated For Operation Over Full Rate Operating Temperature Range
- Adjustable Output Voltage
- Fast Turn-on Response
- Sink Current Capability 1mA to 100mA
- Low (0.2Ω Typ.) Dynamic Output Impedance
- Low Output Noise

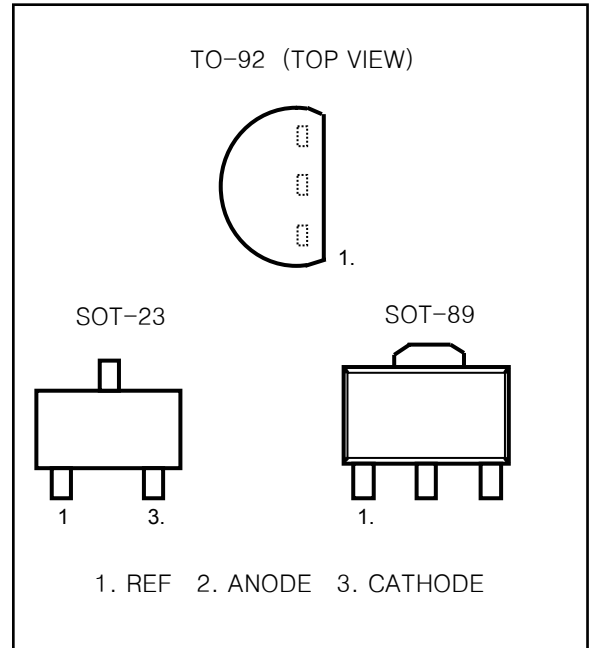

FUNCTION BLOCK DIAGRAM

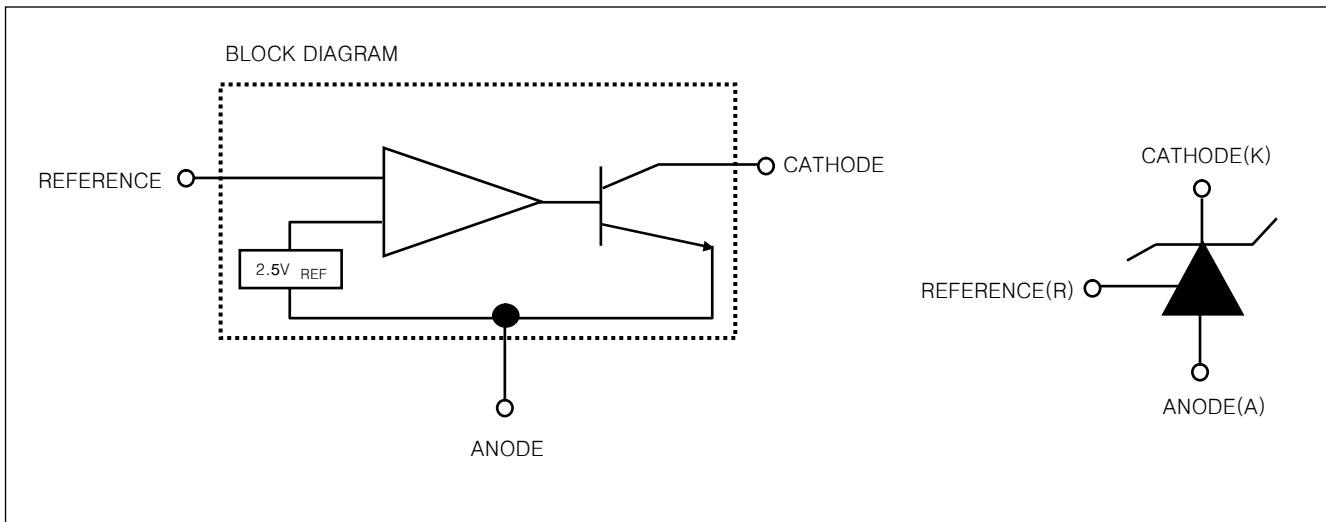

PROGRAMMABLE PRECISION REFERENCES
ABSOLUTE MAXIMUM RATINGS

(Full Operating Ambient Temperature Range Applies Unless Otherwise Noted)

CHARACTERISTIC	SYMBOL	RATING	UNIT
Cathode Voltage	V_{KA}	37	V
Continuous Cathode Current Range	I_{KA}	-100~+150	mA
Reference Input Current Range	I_{REF}	0.05~10	mA
Junction Temperature	T_J	150	°C
Operating Temperature	T_{OPR}	-20 ~ 85	°C
Storage Temperature	T_{STG}	-65 ~ 150	°C
Total Power Dissipation	P_D	700	mW

TL431-0.3% ELECTRICAL CHARACTERISTIC ($T_A=25^\circ\text{C}$, unless otherwise specified)

CHARACTERISTIC	SYMBOL	CIR-CUIT	TEST CONDITION	MIN.	TYP.	MAX.	UNIT
Reference Input Voltage	V_{REF}	1	$V_{KA}=V_{REF}, I_K=10\text{mA}$	2.487V	2.495V	2.502V	
Deviation of Reference Input Voltage Over Full Temperature Range	$\Delta V_{REF}/\Delta T$	1	$V_{KA}=V_{REF}, I_K=10\text{mA}$ $T_A=\text{Full Range}$		3	17	mV
Ratio of Change in Reference Input Voltage to the Change in Cathode Voltage	$\Delta V_{REF}/\Delta V_{KA}$	2	$I_K=10\text{mA}$	$\Delta V_{KA}=10\text{V}-V_{REF}$	-1.4	-2.7	mV/V
				$\Delta V_{KA}=36\text{V}-10\text{V}$	-1	-2	
Reference Input Current	I_{REF}	2	$I_{KA}=10\text{mA}, R1=10\text{k}\Omega, R2=\infty$		1.8	4	μA
Deviation of Reference Input Current Over Full Temperature Range	$\Delta I_{REF}/\Delta T$	2	$I_K=10\text{mA}, R1=10\text{k}\Omega, R2=\infty$ $T_A=\text{Full Range}$		0.4	1.2	μA
Minimum Cathode Current for Regulation	$I_{KA\text{MIN}}$	1	$\Delta V_{KA}=V_{REF}$		0.5	1	mA
Off-State Cathode Current	$I_{KA\text{OFF}}$	3	$V_{KA}=36\text{V}, V_{REF}=0$		0.2	1	μA
Dynamic Impedance	Z_{KA}	1	$V_{KA}=V_{REF}, I_K=1\text{mA}\sim 100\text{mA},$ $f\leq 1\text{kHz}$		0.2	0.5	Ω

PROGRAMMABLE PRECISION REFERENCES
TL431-0.5%ELECTRICAL CHARACTERISTIC ($T_A=25^{\circ}\text{C}$, unless otherwise specified)

CHARACTERISTIC	SYMBOL	CIR-CUIT	TEST CONDITION	MIN.	TYP.	MAX.	UNIT
Reference Input Voltage	V_{REF}	1	$V_{KA}=V_{REF}, I_K=10\text{mA}$	2.482V	2.495V	2.507V	
Deviation of Reference Input Voltage Over Full Temperature Range	$\Delta V_{REF}/\Delta T$	1	$V_{KA}=V_{REF}, I_K=10\text{mA}$ $T_A=\text{Full Range}$		3	17	mV
Ratio of Change in Reference Input Voltage to the Change in Cathode Voltage	$\Delta V_{REF}/\Delta V_{KA}$	2	$I_K=10\text{mA}$	$\Delta V_{KA}=10\text{V}-V_{REF}$	-1.4	-2.7	mV/V
				$\Delta V_{KA}=36\text{V}-10\text{V}$	-1	-2	
Reference Input Current	I_{REF}	2	$I_{KA}=10\text{mA}, R1=10\text{k}\Omega, R2=\infty$		1.8	4	μA
Deviation of Reference Input Current Over Full Temperature Range	$\Delta I_{REF}/\Delta T$	2	$I_K=10\text{mA}, R1=10\text{k}\Omega, R2=\infty$ $T_A=\text{Full Range}$		0.4	1.2	μA
Minimum Cathode Current for Regulation	$I_{KA\text{MIN}}$	1	$\Delta V_{KA}=V_{REF}$		0.5	1	mA
Off-State Cathode Current	$I_{KA\text{OFF}}$	3	$V_{KA}=36\text{V}, V_{REF}=0$		0.2	1	μA
Dynamic Impedance	Z_{KA}	1	$V_{KA}=V_{REF}, I_K=1\text{mA}\sim 100\text{mA},$ $f\leq 1\text{kHz}$		0.2	0.5	Ω

TL431-1%ELECTRICAL CHARACTERISTIC ($T_A=25^{\circ}\text{C}$, unless otherwise specified)

CHARACTERISTIC	SYMBOL	CIR-CUIT	TEST CONDITION	MIN.	TYP.	MAX.	UNIT
Reference Input Voltage	V_{REF}	1	$V_{KA}=V_{REF}, I_K=10\text{mA}$	2.47V	2.495V	2.52V	
Deviation of Reference Input Voltage Over Full Temperature Range	$\Delta V_{REF}/\Delta T$	1	$V_{KA}=V_{REF}, I_K=10\text{mA}$ $T_A=\text{Full Range}$		3	17	mV
Ratio of Change in Reference Input Voltage to the Change in Cathode Voltage	$\Delta V_{REF}/\Delta V_{KA}$	2	$I_K=10\text{mA}$	$\Delta V_{KA}=10\text{V}-V_{REF}$	-1.4	-2.7	mV/V
				$\Delta V_{KA}=36\text{V}-10\text{V}$	-1	-2	
Reference Input Current	I_{REF}	2	$I_{KA}=10\text{mA}, R1=10\text{k}\Omega, R2=\infty$		1.8	4	μA
Deviation of Reference Input Current Over Full Temperature Range	$\Delta I_{REF}/\Delta T$	2	$I_K=10\text{mA}, R1=10\text{k}\Omega, R2=\infty$ $T_A=\text{Full Range}$		0.4	1.2	μA
Minimum Cathode Current for Regulation	$I_{KA\text{MIN}}$	1	$\Delta V_{KA}=V_{REF}$		0.5	1	mA
Off-State Cathode Current	$I_{KA\text{OFF}}$	3	$V_{KA}=36\text{V}, V_{REF}=0$		0.2	1	μA
Dynamic Impedance	Z_{KA}	1	$V_{KA}=V_{REF}, I_K=1\text{mA}\sim 100\text{mA},$ $f\leq 1\text{kHz}$		0.2	0.5	Ω

PROGRAMMABLE PRECISION REFERENCES

Fig. 1 Test Circuit for $V_{KA} = V_{REF}$

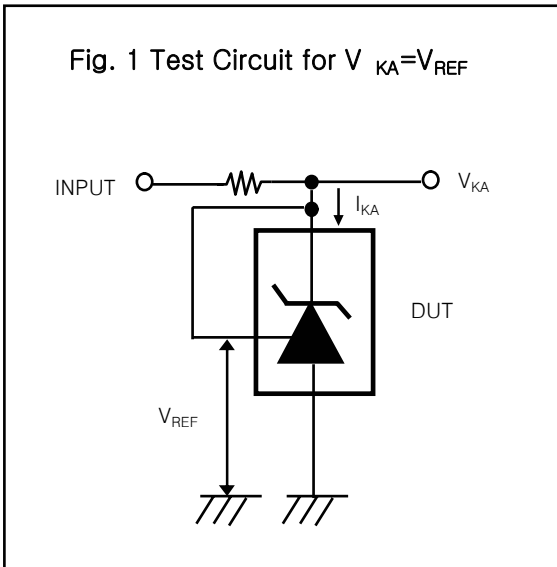

Fig. 2 Test Circuit for $V_{KA} \geq V_{REF}$

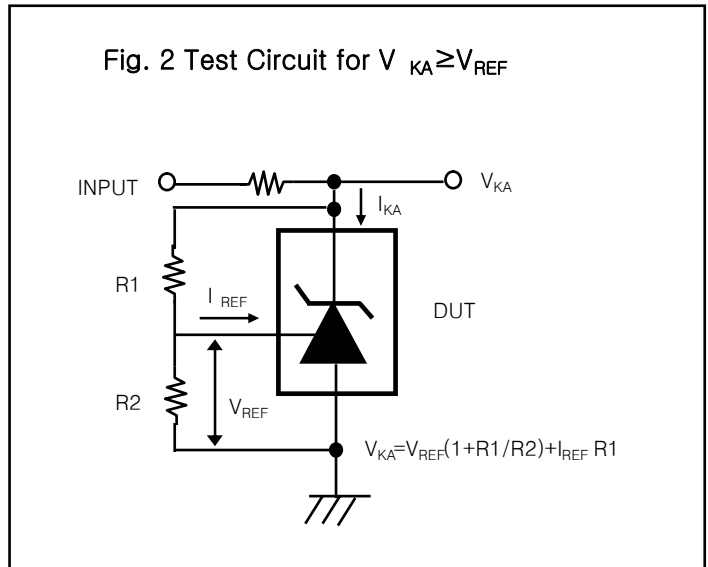
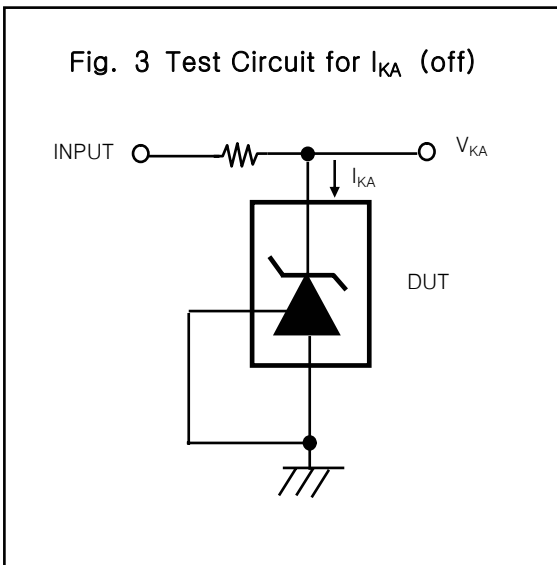
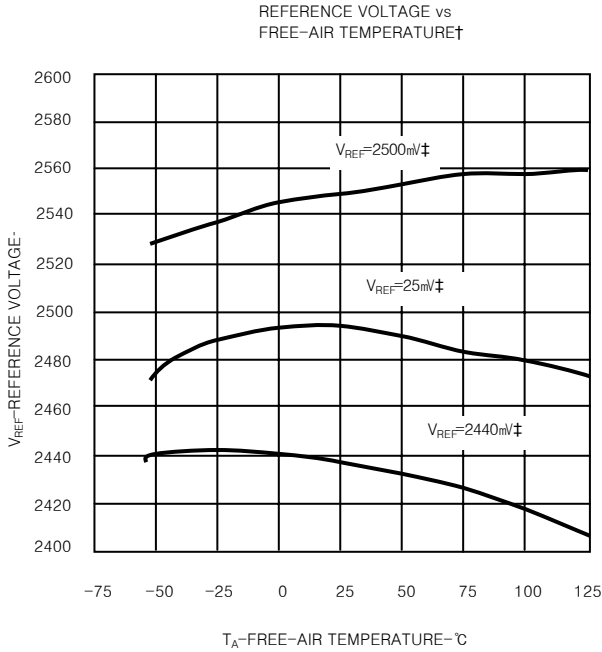

Fig. 3 Test Circuit for I_{KA} (off)



PROGRAMMABLE PRECISION REFERENCES
TYPICAL PERFORMANCE CHARACTERISTICS



† Data is applicable only within the recommended operating free-air temperature ranges of the various devices.

‡ Data is for devices having the indicated value of V_{REF} at $I_{KA}=10mV$, $T_A=25^\circ C$

Figure 4.

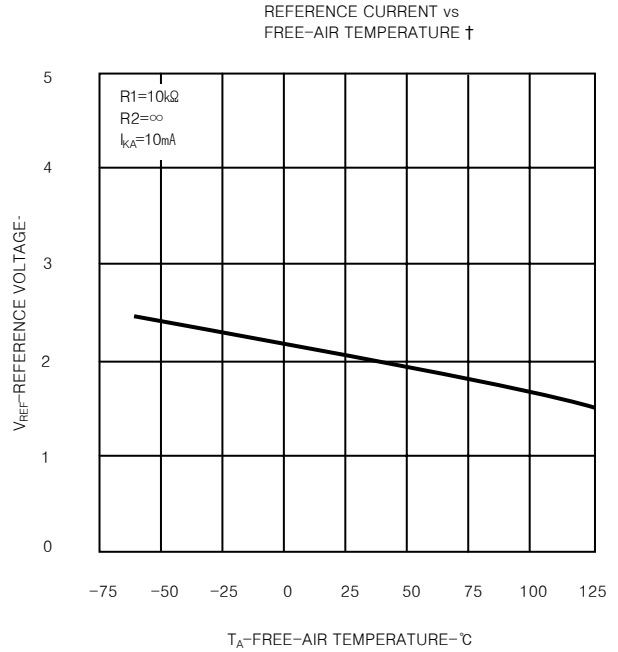

† Data is applicable only within the recommended operating free-air temperature ranges of the various devices.

Figure 5.

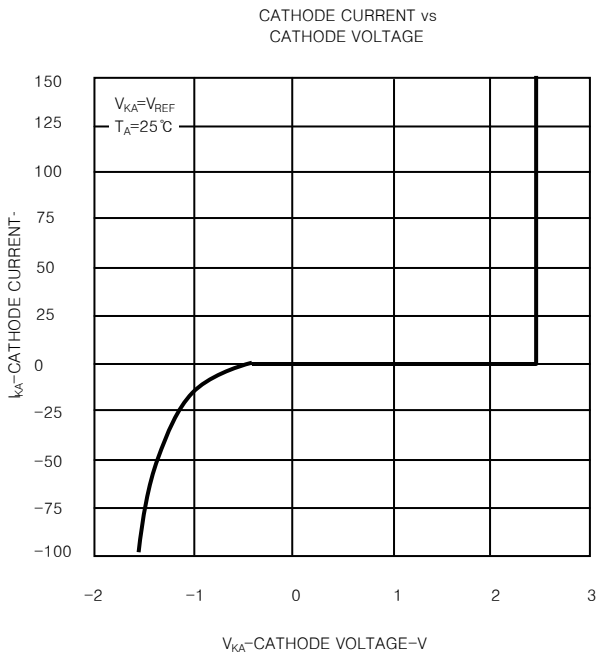

Figure 6.

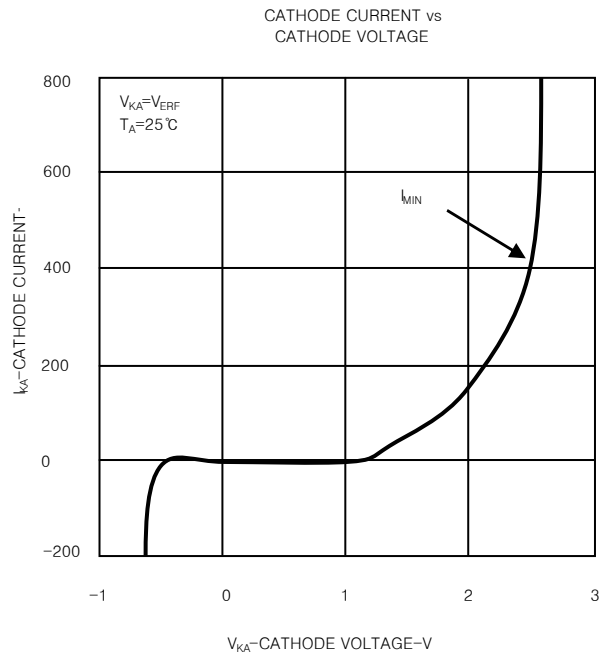
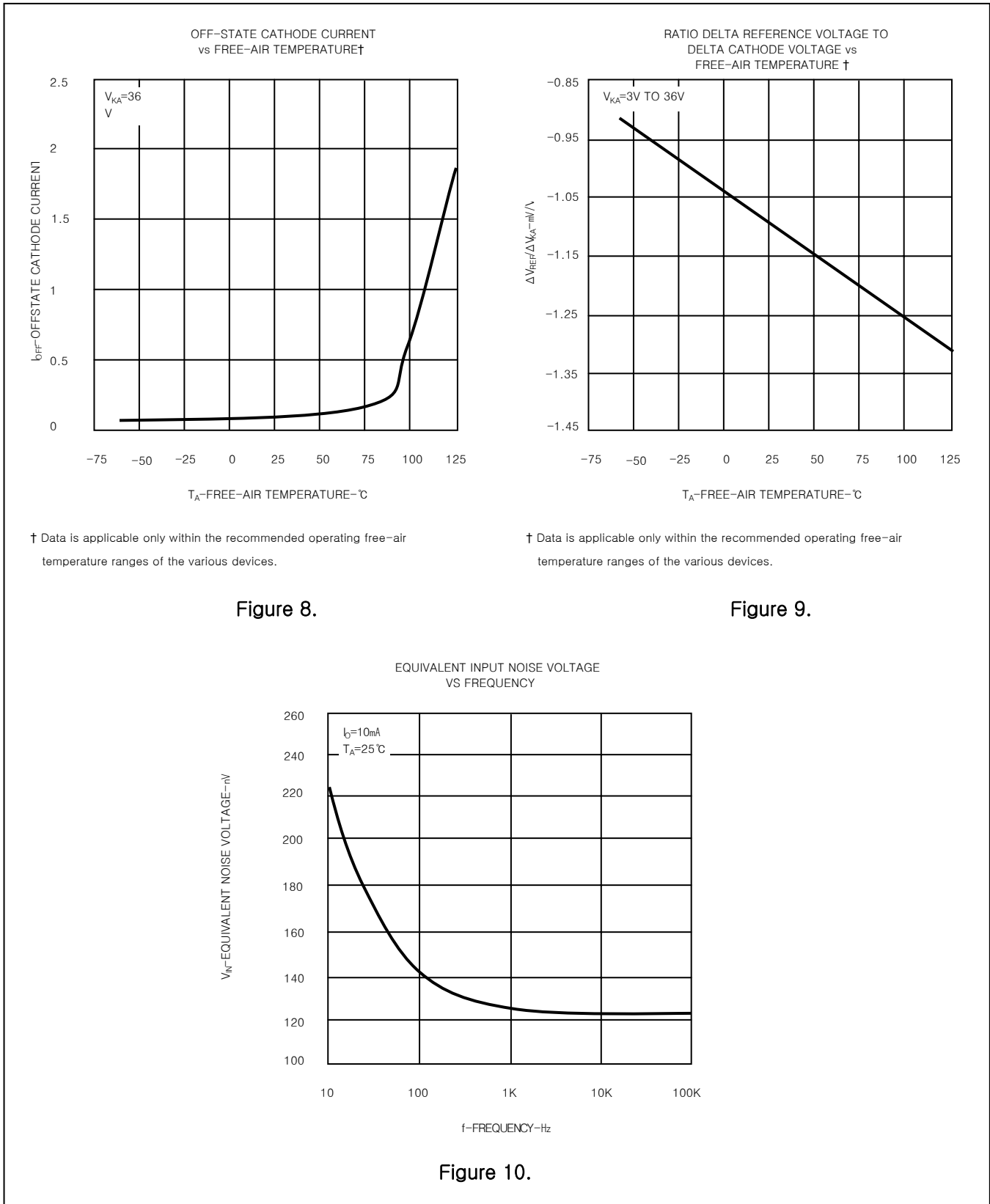

Figure 7.

PROGRAMMABLE PRECISION REFERENCES
TYPICAL PERFORMANCE CHARACTERISTICS



PROGRAMMABLE PRECISION REFERENCES
TYPICAL PERFORMANCE CHARACTERISTICS

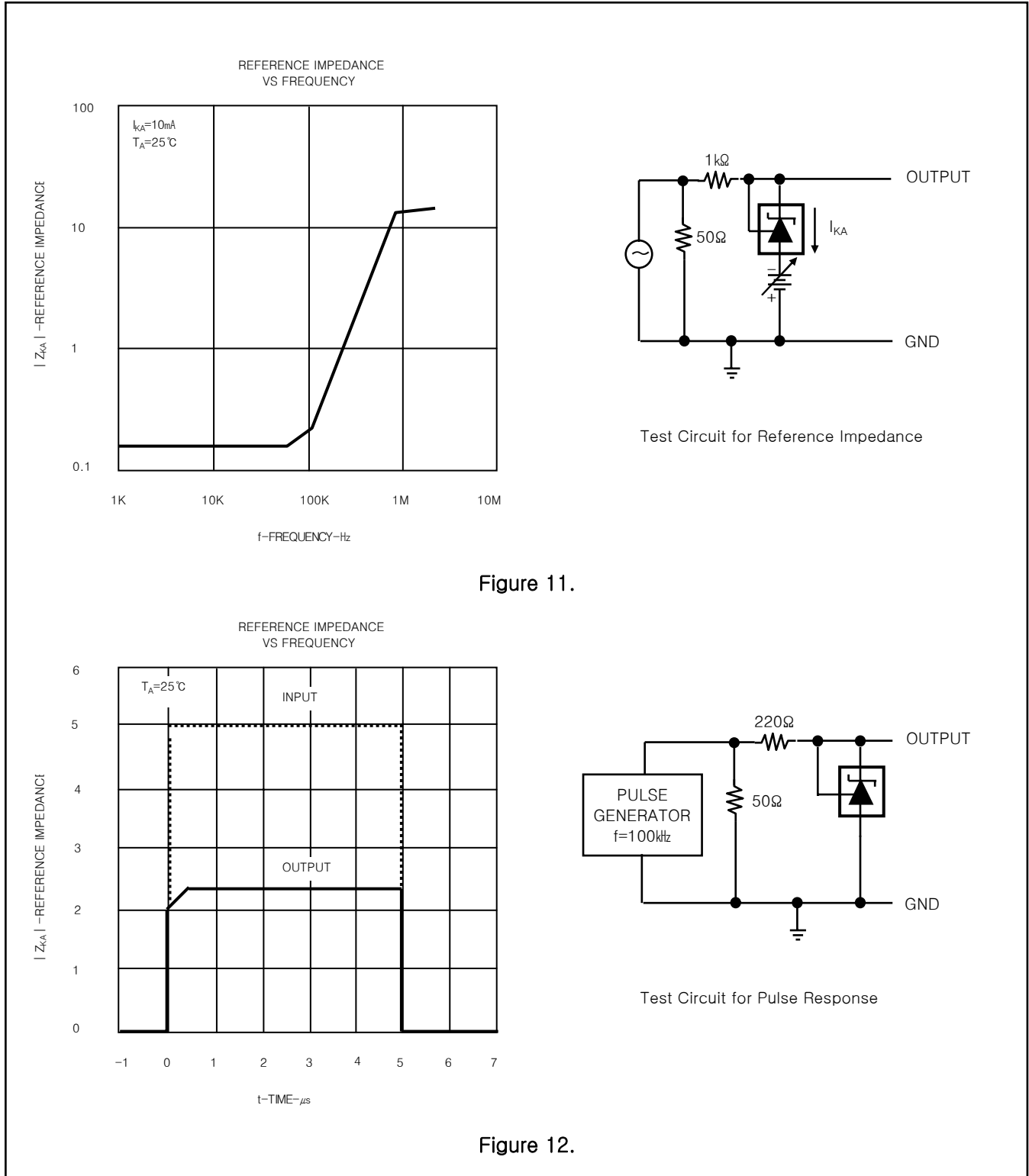
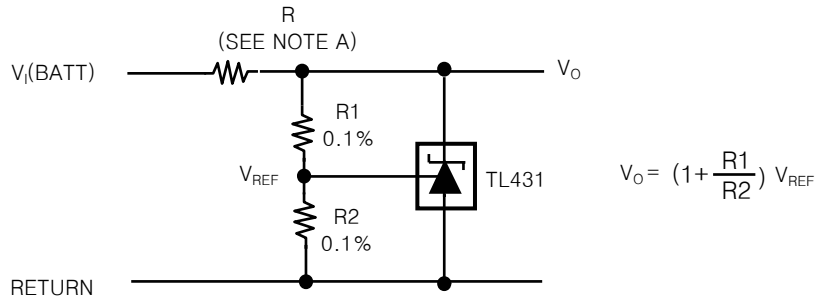

Figure 11.

Figure 12.

PROGRAMMABLE PRECISION REFERENCES

APPLICATION INFORMATION



NOTE A : R Should provide cathode current $\geq 1\text{ mA}$ to the TL431 at minimum $V_1(\text{BATT})$

Figure 13. Shunt Regulator

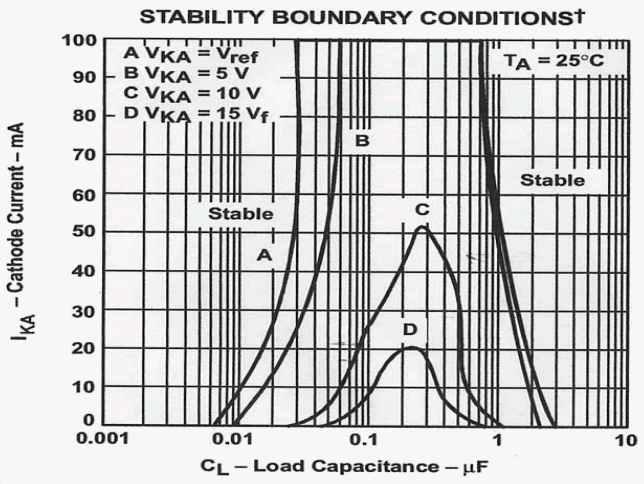

† The areas under the curves represent conditions that may cause the device to oscillate. For curves B, C, and D, R2 and V+ were adjusted to establish the initial V_{KA} and I_{KA} conditions with $C_L = 0$. V_{BATT} and C_L then were adjusted to determine the ranges of stability.

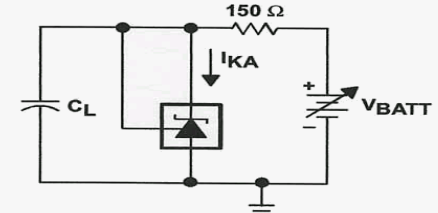

TEST CIRCUIT FOR CURVE A

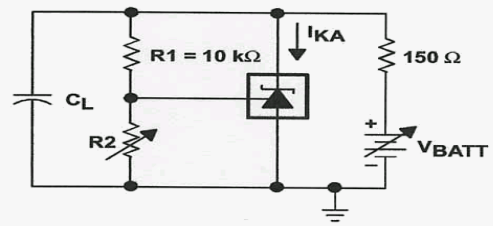

TEST CIRCUIT FOR CURVES B, C, AND D

Figure 14.

X-ON Electronics

Largest Supplier of Electrical and Electronic Components

Click to view similar products for [Voltage References](#) category:

Click to view products by [WPMtek](#) manufacturer:

Other Similar products are found below :

[5962-8686103XC](#) [NCV431BVDMR2G](#) [REF01J/883](#) [SC431ILPRAG](#) [AP432AQG-7](#) [LM4040B25QFTA](#) [TL431BL3T](#) [BR431M](#)
[MC1403BM/TR](#) [HT431BRZ](#) [ME4315AM6G-1](#) [TL431](#) [TL431-1](#) [TL431](#) [TL431S](#) [TL431](#) [XC6206P332MR](#) [LM336Z-2.5](#) [TL431](#) [TL432](#)
[TPR3530-S3TR](#) [TL431ACZ](#) [KA431SLMF2TF](#) [KA431SMF2TF](#) [KA431SMFTF](#) [LM4040QCEM3-3.0/NOPB](#) [LM4041C12ILPR](#)
[LM4050AIM3X-5.0/NOPB](#) [LM4120AIM5-2.5/NOP](#) [LM431SCCMFX](#) [ZXRE250BSA-7](#) [ZXRE125DN8TA](#) [TS3330AQPR](#) [ZXRE250ASA-7](#)
[ZTL431ASE5TA](#) [REF3012AIDBZR](#) [LM385BM-2.5/NOPB](#) [LM385D-2.5R2G](#) [LM4040AIM3-10.0](#) [LM4040BIM3-4.1](#) [LM4040CIM3-10.0](#)
[LM4040CIM3X-2.0/NOPB](#) [LM4041DH5TA](#) [LM4041QDIM3-ADJ/NO](#) [LM4051BIM3-ADJ/NOPB](#) [LM4051CIM3X-1.2/NOPB](#)
[LM4128CMF-1.8/NOPB](#) [LM4132DMF-1.8/NOPB](#) [LM4132EMF-1.8/NOPB](#) [LM4132EMF-2.0/NOPB](#)