

Features

- Low Power Consumption: 8.0uA (Typ)
- Maximum Output Current: 300mA
- Small Dropout Voltage
200mV@100mA (Vout=3.3V)
- Input Voltage Range: 2.0V~6.5V
- Output Voltage Range: 1.2V~5.0V
- (customized on command in 0.1V steps)
- RoHS Compliant and Lead (Pb) Free
- High Accurate: $\pm 2\%$
- Low temperature coefficient
- Output Current Limit
- Integrated Short-Circuit Protection
- Good Transient Response
- Stable with Ceramic Capacitor
- Available Package:
SOT23、SOT23-3L、SOT89-3L

Application

- Battery-powered equipment
- Reference voltage sources
- Mobile phones
- Cameras, video cameras
- Portable games
- Portable games

Description

WL9002 series is a group, low power consumption, low dropout voltage, positive voltage regulators manufactured using CMOS and laser trimming technologies . It can provide 100mA output current when input / output voltage differential drops to 200mV (Vout=3.3V) , The very low power consumption of WL9002 (Iq=8.0uA) can greatly improve natural life of batteries.WL9002 can provide output value in the range of 1.2V~5.0V in 0.1V steps. It also can customized on command.WL9002 includes high accuracy voltage reference, error amplifier, current limit circuit and output driver module.WL9002 has well load transient response and good temperature characteristic, And it uses trimming technique to guarantee output voltage accuracy within $\pm 2\%$.

Application Circuits

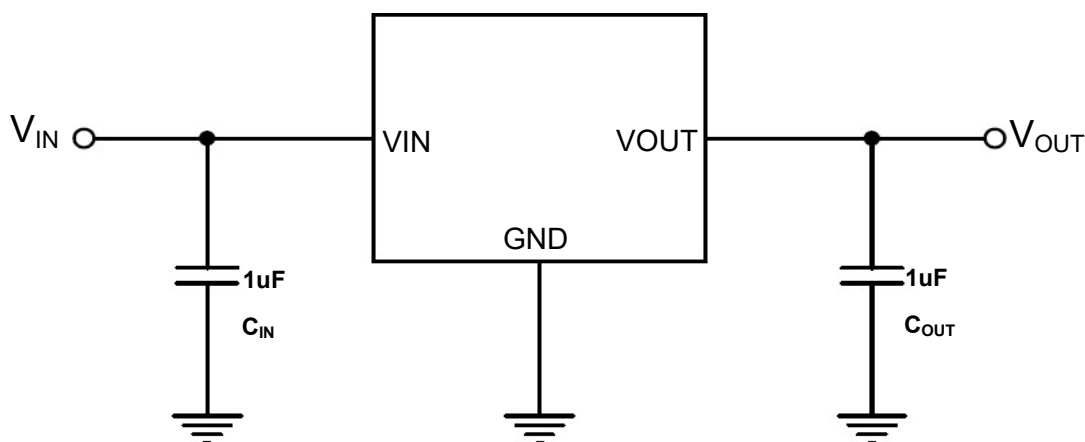

Pin Configuration

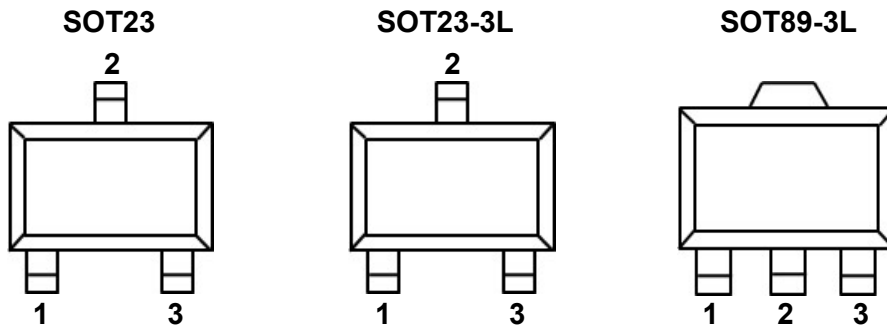

Pin Description

Pin No.			Pin Name	Pin Function
SOT23	SOT23-3L	SOT89-3L		
1	1	1	GND	Ground.
2	2	2	VIN	Supply voltage input.
3	3	3	VOUT	Voltage Output.

Order Information

WL9002①②-③④

Designator	Symbol	Description
①②	M3/S3/P3	SOT23 / SOT23-3L / SOT89-3L
③④	Integer	Output Voltage(12、15、18、25、28、30、33、36.....)

Model*	Marking**	Description	Package	T/R Qty
WL9002M3-XX*	①②③④	WL9002 300mA Low-Dropout Linear voltage regulator	SOT23	3,000 PCS
WL9002S3-XX*	①②③④		SOT23-3L	3,000 PCS
WL9002P3-XX*	①②③④		SOT89-3L	1,000 PCS

Note: (*) XX Represents the Output Voltage

(**) Please refer Page 3

Marking Information

①② Represents the product name

Mark ①	Product Series
6	WL9002 M3 / S3 / P3

③ Represents the range of output voltage

Mark ②		Product Series
VOUT: 1.2V-3.0V	VOUT: 3.1V-5.0V	WL9002 M3 / S3 / P3
5	6	

③ Represents the Output Voltage

Mark③	Output Voltage(V)				Mark③	Output Voltage(V)			
0	-	3.1	-	-	F	1.6	4.6	-	-
1	-	3.2	-	-	H	1.7	4.7	-	-
2	-	3.3	-	-	K	1.8	4.8	-	-
3	-	3.4	-	-	L	1.9	4.9	-	-
4	-	3.5	-	-	M	2.0	5.0	-	-
5	-	3.6	-	-	N	2.1	-	-	-
6	-	3.7	-	-	P	2.2	-	-	-
7	-	3.8	-	-	R	2.3	-	-	--
8	-	3.9	-	-	S	2.4	-	-	-
9	-	4.0	-	-	T	2.5	-	-	-
A	-	4.1	-	-	U	2.6	-	-	-
B	1.2	4.2	-	-	V	2.7	-	-	-
C	1.3	4.3	-	-	X	2.8	-	-	-
D	1.4	4.4	-	-	Y	2.9	-	-	-
E	1.5	4.5	-	-	Z	3.0	-	-	-

NOTE:④ Represents the assembly lot no. 0~9, A~Z repeated (G, I, J, O, Q, W excepted)

Absolute Maximum Ratings ^{(1) (2)}

Parameter		Symbol	Maximum Rating	Unit
Input Voltage		V_{IN}	$V_{SS} - 0.3 \sim V_{SS} + 7.0$	V
Output Current		I_{OUT}	350	mA
Output Voltage		V_{OUT}	$V_{SS} - 0.3 \sim V_{IN} + 0.3$	V
Power Dissipation	SOT23	P_d	200	mW
	SOT23-3		250	
	SOT89-3		500	
Thermal Resistance	SOT23	$R_{\theta JA}^{(3)}$ (Junction-to-ambient thermal resistance)	500	$^{\circ}C/W$
	SOT23-3		400	$^{\circ}C/W$
	SOT89-3		200	$^{\circ}C/W$
Operating Temperature		T_{opr}	-40~85	$^{\circ}C$
Storage Temperature		T_{stg}	-40~125	$^{\circ}C$
Soldering Temperature & Time		T_{solder}	260 $^{\circ}C$, 10s	

Note (1): Exceeding these ratings may damage the device.

Note (2): The device is not guaranteed to function outside of its operating conditions

Note (3): The package thermal impedance is calculated in accordance to JESD 51-7.

ESD Ratings

Item	Description	Value	Unit
$V_{(ESD-HBM)}$	Human Body Model (HBM) ANSI/ESDA/JEDEC JS-001-2014 Classification, Class: 2	± 4000	V
$V_{(ESD-CDM)}$	Charged Device Mode (CDM) ANSI/ESDA/JEDEC JS-002-2014 Classification, Class: C0b	± 400	V
$I_{LATCH-UP}$	JEDEC STANDARD NO.78E APRIL 2016 Temperature Classification, Class: I	± 400	mA

ESD testing is performed according to the respective JESD22 JEDEC standard. The human body model is a 100 pF capacitor discharged through a 1.5k Ω resistor into each pin. The machine model is a 200pF capacitor discharged directly into each pin.

Recommended Operating Conditions

Parameter	MIN.	MAX.	Units
Supply voltage at V_{IN}	2.0	6.5	V
Operating junction temperature range, T_j	-40	125	$^{\circ}C$
Operating free air temperature range, T_A	-40	85	$^{\circ}C$

Note : All limits specified at room temperature ($T_A = 25^{\circ}C$) unless otherwise specified. All room temperature limits are 100% production tested. All limits at temperature extremes are ensured through correlation using standard Statistical Quality Control (SQC) methods. All limits are used to calculate Average Outgoing Quality Level (AOQL).

Electrical Characteristics

(Test Conditions: $C_{IN}=1\mu F$, $C_{OUT}=1\mu F$, $T_A=25^\circ C$, unless otherwise specified.)

Parameter	Symbol	Conditions	Min	Typ	Max	Units
Input Voltage	V_{IN}		-0.3		6.5	V
Quiescent Current	I_Q	$V_{OUT} \leq V_{IN}$ $I_{LOAD}=0mA$ ⁽²⁾		8.0		μA
Output Voltage	V_{OUT}	$V_{IN}=V_{set}+1.0V$ $I_{OUT}=30mA$	$V_{set} \cdot 0.98$	V_{set}	$V_{set} \cdot 1.02$	V
Maximum Output Current	$I_{OUT(Max)}$	$V_{IN}=V_{OUT}+1.0V$	300 ⁽¹⁾			mA
Dropout Voltage	V_{DROP}	$I_{OUT}=100mA$ $V_{OUT}=3.3V$		200		mV
Line Regulation	$\frac{\Delta V_{OUT}}{\Delta V_{IN} \cdot V_{OUT}}$	$I_{OUT}=40mA$ $(V_{set}+1.0V) \leq V_{IN} \leq 7.0V$		0.05		%/V
Load Regulation	ΔV_{OUT}	$V_{IN}=V_{set}+1.0V$ $1mA \leq I_{OUT} \leq 100mA$		30		mV
Short Current	I_{SHORT}	$V_{IN}=V_{set}+1.0V$ $V_{OUT}=GND$		10		mA
Current Limit	I_{LIMIT}		—	350	—	mA
Power Supply Rejection Rate	PSRR	$V_{IN}=V_{set}+1.0V$ $f=1KHz, I_{OUT}=40mA$		50		dB
Output Voltage Temperature Coefficient	$\frac{\Delta V_{OUT}}{\Delta T \cdot V_{OUT}}$	$I_{OUT}=10mA$		100		ppm/ $^\circ C$

NOTE:(1) $I_{OUT}=P_d / (V_{IN}-V_{OUT})$

(2) WL9002 keeps the chip low power when the input voltage is low

Function Block Diagram

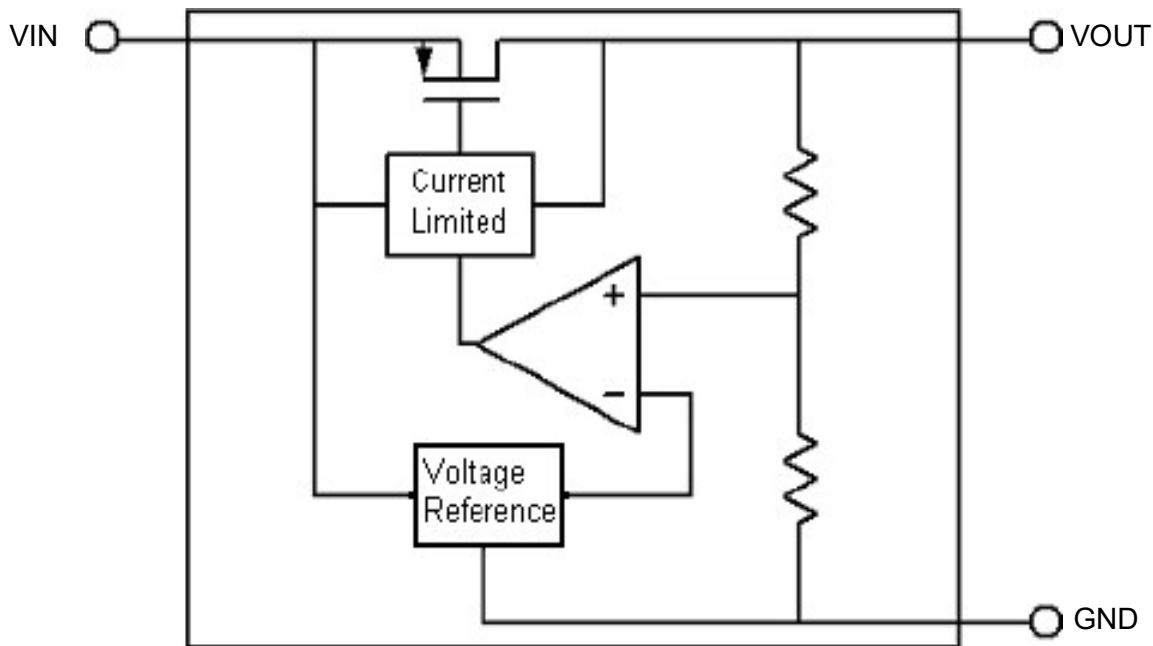

Application Guideline

Input Capacitor

A 1 μ F ceramic capacitor is recommended to connect between V_{DD} and GND pins to decouple input power supply glitch and noise. The amount of the capacitance may be increased without limit. This input capacitor must be located as close as possible to the device to assure input stability and less noise. For PCB layout, a wide copper trace is required for both VIN and GND.

Output Capacitor

An output capacitor is required for the stability of the LDO. The recommended output capacitance is 1 μ F, ceramic capacitor is recommended, and temperature characteristics are X7R or X5R. Higher capacitance values help to improve load/line transient response. The output capacitance may be increased to keep low undershoot/overshoot. Place output capacitor as close as possible to VOUT and GND pins.

Dropout Voltage

The dropout voltage refers to the voltage difference between the VIN and VOUT pins while operating at specific output current. The dropout voltage V_{DROPO} also can be expressed as the voltage drop on the pass-FET at specific output current (I_{RATED}) while the pass-FET is fully operating at ohmic region and the pass-FET can be characterized as a resistance $R_{DS(ON)}$. Thus the dropout voltage

can be defined as ($V_{DROP} = V_{IN} - V_{OUT} = R_{DS(ON)} \times I_{RATED}$). For normal operation, the suggested LDO operating range is ($V_{IN} > V_{OUT} + V_{DROP}$) for good transient response and PSRR ability. Vice versa, while operating at the ohmic region will degrade the performance severely.

Thermal Application

For continuous operation, do not exceed the absolute maximum junction temperature. The maximum power dissipation depends on the thermal resistance of the IC package, PCB layout, rate of surrounding airflow, and difference between junction and ambient temperature. The maximum power dissipation can be calculated as below: $T_A = 25^\circ\text{C}$, PCB,

The max PD = $(125^\circ\text{C} - 25^\circ\text{C}) / (\text{Thermal Resistance } ^\circ\text{C/W})$

Power dissipation (PD) is equal to the product of the output current and the voltage drop across the output pass element, as shown in the equation below:

$$PD = (V_{IN} - V_{OUT}) \times I_{OUT}$$

Layout Consideration

By placing input and output capacitors on the same side of the PCB as the LDO, and placing them as close as is practical to the package can achieve the best performance. The ground connections for input and output capacitors must be back to the WL9002 ground pin using as wide and as short of a copper trace as is practical. Connections using long trace lengths, narrow trace widths, and/or connections through via must be avoided. These add parasitic inductances and resistance that results in worse performance especially during transient conditions.

Packaging Information

SOT23

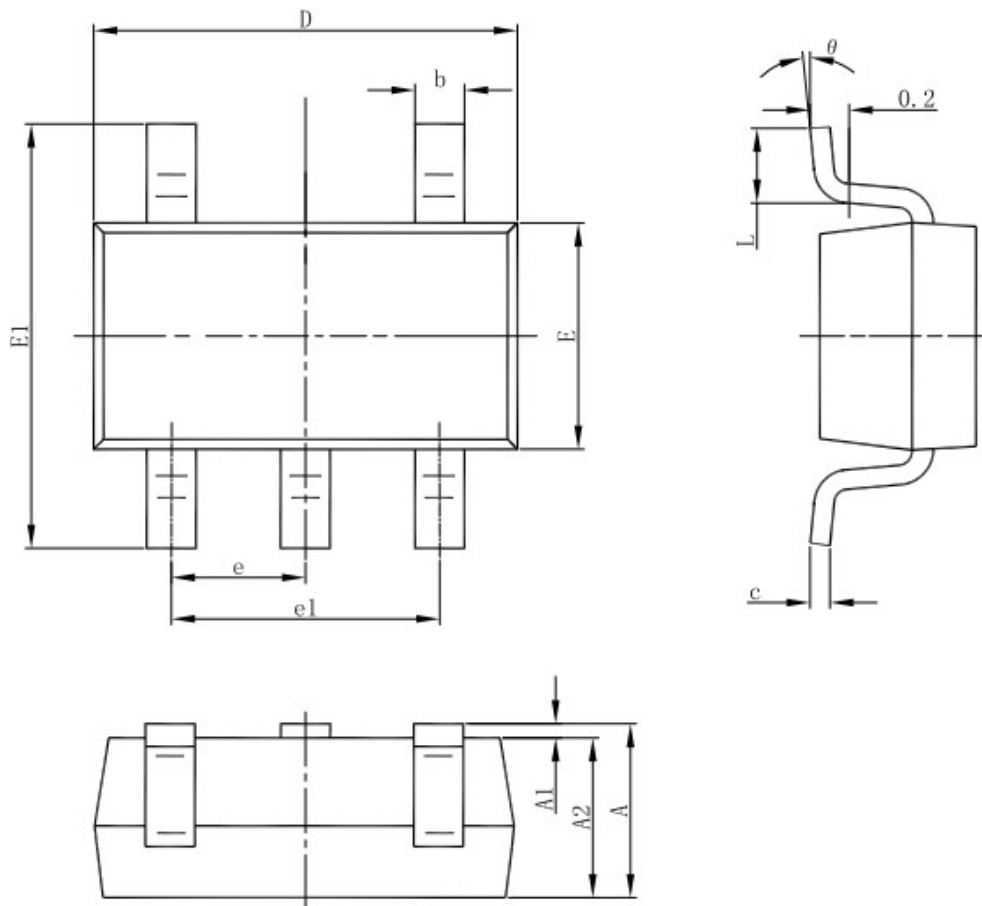

Symbol	Dimensions In Millimeters		Dimensions In Inches	
	Min	Max	Min	Max
A	1.050	1.250	0.041	0.049
A1	0.000	0.100	0.000	0.004
A2	1.050	1.150	0.041	0.045
b	0.300	0.500	0.012	0.020
c	0.100	0.200	0.004	0.008
D	2.820	3.020	0.111	0.119
E	1.500	1.700	0.059	0.067
E1	2.650	2.950	0.104	0.116
e	0.950(BSC)		0.037(BSC)	
e1	1.800	2.000	0.071	0.079
L	0.300	0.600	0.012	0.024
θ	0°	8°	0°	8°

Packaging Information

SOT23-3L

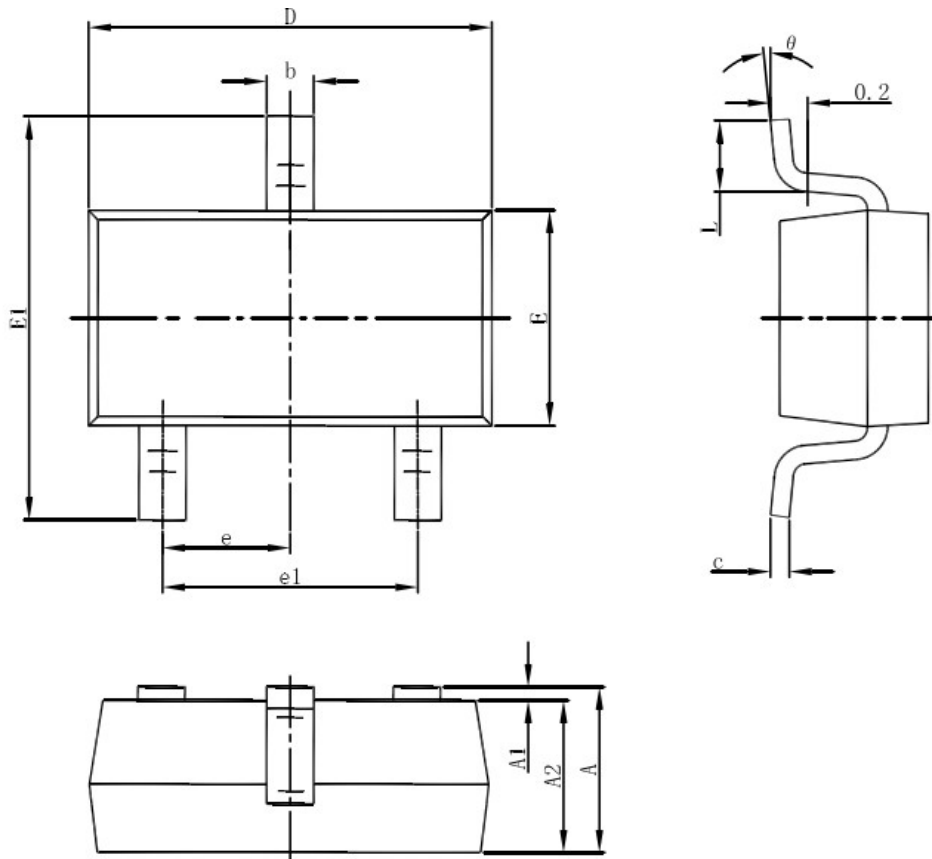

Symbol	Dimensions In Millimeters		Dimensions In Inches	
	Min	Max	Min	Max
A	1.050	1.250	0.041	0.049
A1	0.000	0.100	0.000	0.004
A2	1.050	1.150	0.041	0.045
b	0.300	0.500	0.012	0.020
c	0.100	0.200	0.004	0.008
D	2.820	3.020	0.111	0.119
E	1.500	1.700	0.059	0.067
E1	2.650	2.950	0.104	0.116
e	0.950(BSC)		0.037(BSC)	
e1	1.800	2.000	0.071	0.079
L	0.300	0.600	0.012	0.024
θ	0°	8°	0°	8°

Packaging Information

SOT89-3L

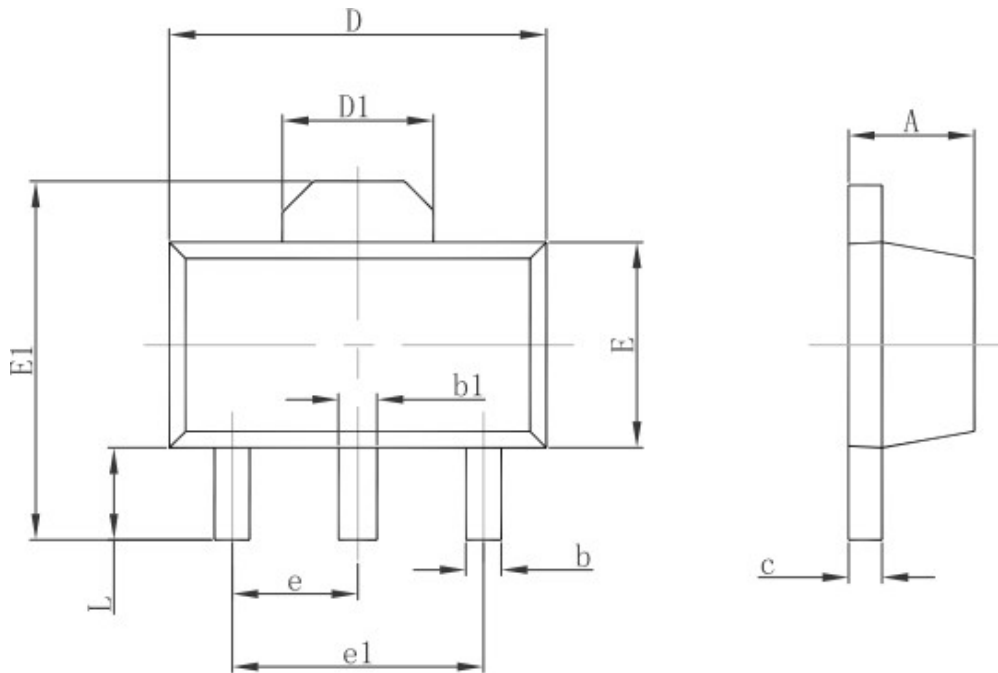

Symbol	Dimensions In Millimeters		Dimensions In Inches	
	Min.	Max.	Min.	Max.
A	1.400	1.600	0.055	0.063
b	0.320	0.520	0.013	0.020
b1	0.400	0.580	0.016	0.023
c	0.350	0.440	0.014	0.017
D	4.400	4.600	0.173	0.181
D1	1.550 REF.		0.061 REF.	
E	2.300	2.600	0.091	0.102
E1	3.940	4.250	0.155	0.167
e	1.500 TYP.		0.060 TYP.	
e1	3.000 TYP.		0.118 TYP.	
L	0.900	1.200	0.035	0.047

X-ON Electronics

Largest Supplier of Electrical and Electronic Components

Click to view similar products for [Linear Voltage Regulators](#) category:

Click to view products by [WPMtek](#) manufacturer:

Other Similar products are found below :

[LV5684PVD-XH](#) [MCDTSA6-2R](#) [L7815ACV-DG](#) [LV56801P-E](#) [UA7805CKC](#) [714954EB](#) [ZMR500QFTA](#) [BA033LBSG2-TR](#)
[NCV78M05ABDTRKG](#) [LV5680P-E](#) [L79M05T-E](#) [L78LR05D-MA-E](#) [NCV317MBTG](#) [NTE7227](#) [MP2018GZD-33-P](#) [MP2018GZD-5-P](#)
[LV5680NPVC-XH](#) [ZTS6538SE](#) [UA78L09CLP](#) [UA78L09CLPR](#) [CAT6221-PPTD-GT3](#) [MC78M09CDTRK](#) [NCV51190MNTAG](#)
[BL1118CS8TR1833](#) [BL8077CKETR33](#) [BL9153-33CC3TR](#) [BL9161G-28BADRN](#) [BRCO7530MMC](#) [CJ7815B-TFN-ARG](#) [LM317C](#)
[GM7333K](#) [GM7350K](#) [XC6206P332MR](#) [HT7533](#) [LM7912S/TR](#) [LT1764S/TR](#) [LM7805T](#) [LM338T](#) [LM1117IMP-3.3/TR](#) [HT1117AM-3.3](#)
[HT7550S](#) [AMS1117-3.3](#) [HT7150S](#) [78L12](#) [HT7550](#) [HT7533-1](#) [HXY6206I-2.5](#) [HT7133](#) [HT7533S](#) [662K](#)