



Quick Start Guide

Mag³C Power Module Evaluation Board
for 172946001 T0263

Evaluation Board
178946001

Version 2.0

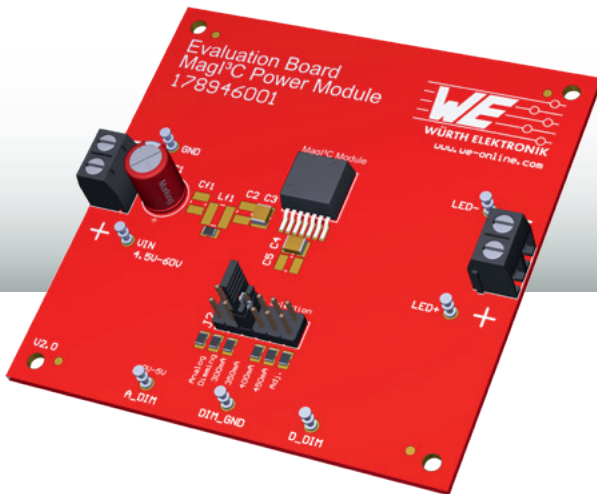

 **WARNING!** – Before operating read the attached IMPORTANT NOTICE document!

Schematic

Features

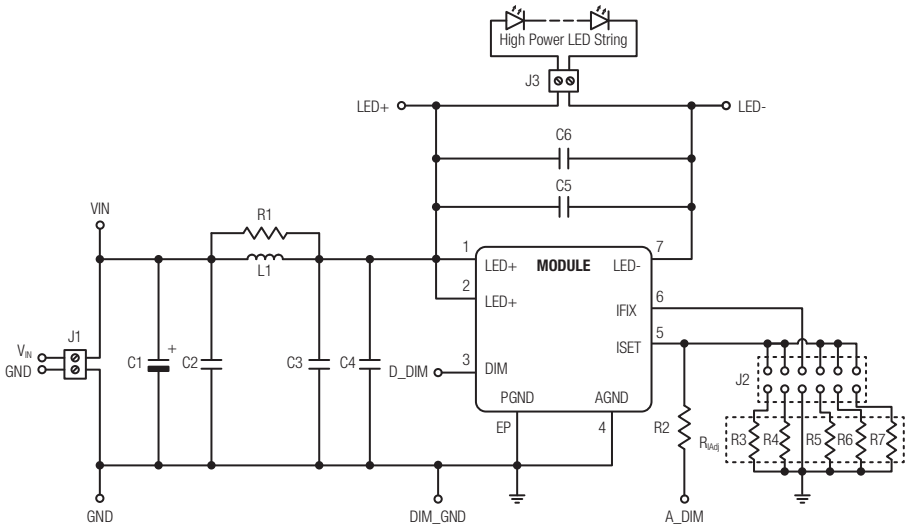

The additional aluminum electrolytic capacitor C1 is only for evaluation board protection purposes. It is mounted at the termination of the supply line and provides slight damping of possible oscillations of the series resonance circuit represented by the inductance of the supply line and the input capacitance. It is not essential for operation.

For accurate V_{IN} and V_{OUT} voltage measurements it is recommended to measure directly at the input and output capacitors C4 and C5.

It is **not** recommended to use this evaluation board with input and output wire lengths longer than 1 m.

For the datasheet of the power module visit us at: www.we-online.de/katalog/de/MAGIC-LDHM-TOP263-7EP



This product is highly sensitive to electrostatic discharge (ESD). As such, always use proper ESD precautions when handling. Failing to follow the aforementioned recommendations can result in severe damage to the part.

WARNING! – Before operating read the attached IMPORTANT NOTICE document!



Ref.Des.	Description (Order Code)		
U1	MagI ² C Power Module (172946001)		
C1	Aluminum electrolytic capacitor 27 μ F 100V (860040874001)		
C2	N.p. filter capacitor		
C3	N.p. ceramic chip capacitor 2.2 μ F 100V (885012209071)		
C4	Ceramic chip capacitor 2.2 μ F 100V (885012209071)		
C5	Ceramic chip capacitor 2.2 μ F 100V (885012209071)		
C6	N.p. ceramic chip capacitor 2.2 μ F 100V (885012209071)		
L1	N.p. filter inductor		
R1	OR filter inductor bypass		
R2	28 k for $V_{ADIM} = 0-5V$	$R_{ADIM} = \frac{V_{ADIM} \cdot k}{I_{LED, max} - I_{LED, min}}$	
R3	R_IADJ set by jumper	2.55 k for analog dimming: $I_{LED} = 300\text{ mA to }450\text{ mA}$ $R_{IADJ} = \frac{V_{ADIM} \cdot V_{REF} \cdot k}{V_{ADIM} \cdot I_{LED, max} - V_{REF} \cdot (I_{LED, max} - I_{LED, min})}$	
R4		3.48 k for $I_{LED} = 300\text{ mA}$	
R5		I_{FIX} for $I_{LED} = 350\text{ mA}$	
R6		2.61 k for $I_{LED} = 400\text{ mA}$	
R7		2.32 k for $I_{LED} = 450\text{ mA}$	
R7		To be soldered for adjustable output current	$I_{LED} = \frac{V_{REF} \cdot k}{R_{IADJ}}$
J1		Terminal block for input voltage (691502710002)	
J2	Jumper for output current selection (61301221121)		
J3	Terminal block for High Power LED String (691502710002)		

* $V_{REF} = 1.25V$, $k = 840$



For layout, Gerber and STP files visit us on:
www.we-online.de/katalog/de/
 EVALUATION_BOARDS_LED_DRIVER

Overview

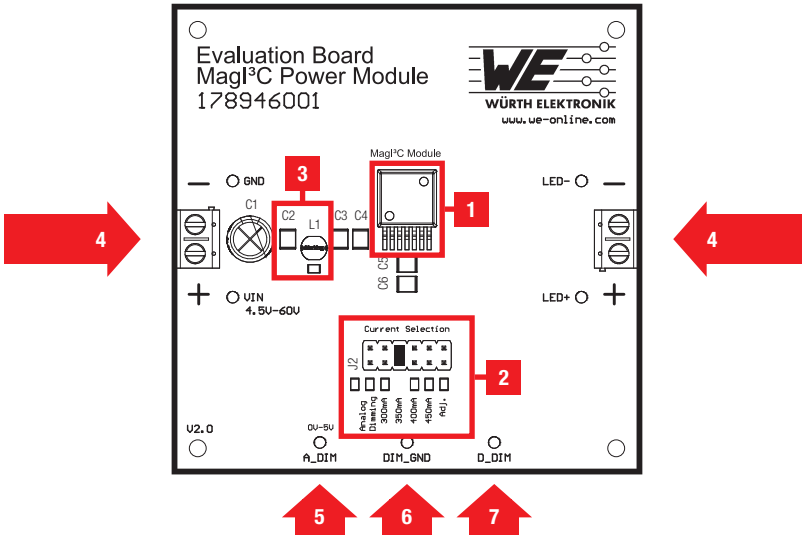

Description

V_{IN} 4.5–60V **V_{OUT}** 4.5–60V **I_{OUT}** 450 mA

- 1 LDHM LED Step Down High Current Module T0263
- 2 Jumpers (J2) for current selection
- 3 Optional input filter
- 4 Terminal blocks for input and output cables with 0.326–2.08 mm² max diameter
- 5 Test clip connection for analog dimming
- 6 Test clip connection for dimming ground
- 7 Test clip connection for digital dimming
- Default jumper position

Absolute maximum ratings

Caution: Exceeding the abs. max. values given in the datasheet may affect the device negatively and may cause permanent damage.



This evaluation board is intended to be operated in a research and development environment under the supervision of qualified technicians and engineers who are trained and experienced in the safe use of electronics. This evaluation board was designed and tested according to CISPR15 Class B standards under Würth Elektronik laboratory test conditions, as indicated in the data sheet of the corresponding power module. Operation in other test setups may cause unintended electrical behavior and exceed the stated performance and limits imposed by the CISPR15 Class B standards. This evaluation board is not intended for usage in final applications. This evaluation board is not intended for resale.



X-ON Electronics

Largest Supplier of Electrical and Electronic Components

Click to view similar products for [LED Lighting Development Tools](#) category:

Click to view products by [Wurth](#) manufacturer:

Other Similar products are found below :

[MIC2870YFT EV](#) [ADP8860DBCP-EVALZ](#) [LM3404MREVAL](#) [ADM8843EB-EVALZ](#) [TDGL014](#) [ISL97682IRTZEVALZ](#) [LM3508TLEV](#)
[EA6358NH](#) [MAX16826EVKIT](#) [MAX16839EVKIT+](#) [TPS92315EVM-516](#) [MAX1698EVKIT](#) [MAX6956EVKIT+](#) [OM13321,598](#) [DC986A](#)
[DC909A](#) [DC824A](#) [STEVAL-LLL006V1](#) [IS31LT3948-GRLS4-EB](#) [104PW03F](#) [PIM526](#) [PIM527](#) [MAX6946EVKIT+](#) [MAX20070EVKIT#](#)
[MAX21610EVKIT#](#) [MAX20090BEVKIT#](#) [MAX20092EVSYS#](#) [PIM498](#) [AP8800EV1](#) [ZXLD1370/1EV4](#) [MAX6964EVKIT](#)
[MAX25240EVKIT#](#) [MAX25500TEVKITC#](#) [MAX77961BEVKIT06#](#) [1216.1013](#) [TPS61176EVM-566](#) [TPS61197EVM](#) [TPS92001EVM-628](#)
[1270](#) [1271.2004](#) [1272.1030](#) [1273.1010](#) [1278.1010](#) [1279.1002](#) [1279.1001](#) [1282.1000](#) [1293.1900](#) [1293.1800](#) [1293.1700](#) [1293.1500](#)