

Spezifikation für Freigabe / specification for release

Kunde / customer :
 Artikelnummer / part number : **749023010A**
 Bezeichnung : **LAN-Übertrager WE-LAN**
 description : **LAN-Transformer WE-LAN**



DATUM / DATE : 2018-10-15

A Mechanische Abmessungen / dimensions :

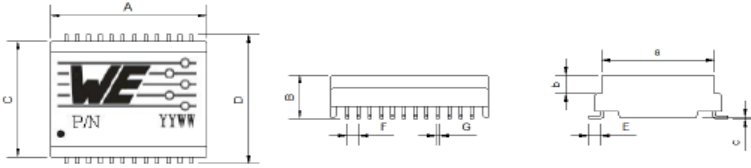

	1000 BaseT	
A	17,50 ± 0,25	mm
B	5,4 ± 0,25	mm
C	14,20 ± 0,25	mm
D	15,60 ± 0,25	mm
E	1,50 ± 0,15	mm
F	1,27 ± 0,10	mm
G	0,30 ± 0,10	mm
a	12,70 ± 0,25	mm
b	2,30 ± 0,25	mm
c	0,30 ± 0,15	mm

B Elektrische Eigenschaften / electrical properties :

Eigenschaften / properties	Testbedingungen / test conditions		Wert / value	Einheit / unit	tol.
Induktivität / Inductance	100kHz / 100mV @ 8mA DC-Bias	OCL	350	µH	min.
Übersetzungsverhältnis / Turns ratio	100kHz / 100mV	TR	1 : 1	Tx	3%
Insertion Loss	1-100 MHz	IL	-1,1	dB	
Return Loss	1-30MHz @ 100Ω	RL	-18	dB	min.
	30-60MHz @ 100Ω		-14		
	60-80MHz @ 100Ω		-12		
	80-100MHz @ 100Ω		-10		
Differential to Common Mode Rejection Ratio	1-30MHz	DCMR	-40	dB	min.
	30-60MHz		-35		
Crosstalk	1-60MHz	CT	-35	dB	min.
	60-100MHz		-30		

C Lötpad / soldering spec. :

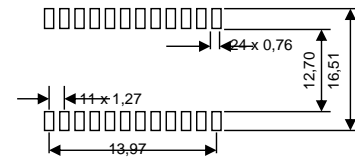

D Prüfgeräte / test equipment :

HP4395A

E Testbedingungen / test conditions :

Luftfeuchtigkeit / humidity: 33%
 Umgebungstemperatur / temperature: +25°C

F Werkstoffe & Zulassungen / material & approvals :

Basismaterial / base material: Ferrit / ferrite
 Draht / wire: 0UEW QPN180
 Kontaktmaterial / contact plating: Cu-Ni-Sn
 Gehäuse / case: UL94-V0
 Verguss / potting: UL94-V0

G Eigenschaften / general specifications :

Betriebstemp. / operating temperature: 0°C - + 70°C
 Hochspannungsprüfung / Hipot test: 1500Vrms 1min.
 Geeignet für 1000BaseT-Anwendungen gemäß IEEE 802.3af /
 Compliant with IEEE 802.3af for 1000BaseT
 Geeignet für Power over Ethernet-Anwendungen (350 mA) /
 Suitable for Power over Ethernet applications (350 mA)

Freigabe erteilt / general release:	Kunde / customer		
.....		
Datum / date	Unterschrift / signature		
.....	Würth Elektronik		
.....		
Geprüft / checked	Kontrolliert / approved		
.....		
	JaB	Revision 05	2018-10-15
	JaB	Revision 04	2015-01-26
	LuRa	Revision 03	2014-07-28
	LuRa	Revision 02	2014-01-20
	Mle	Revision 01	2013-04-22
	Mle	Revision 00	2012-11-09
	Name	Änderung / modification	Datum / date

Würth Elektronik eiSos GmbH & Co.KG

D-74638 Waldenburg · Max-Eyth-Straße 1 - 3 · Germany · Telefon (+49) (0) 7942 - 945 - 0 · Telefax (+49) (0) 7942 - 945 - 400
<http://www.we-online.com>

Spezifikation für Freigabe / specification for release

Kunde / customer :
 Artikelnummer / part number : **749023010A**
 Bezeichnung : **LAN-Übertrager WE-LAN**
 description : **LAN-Transformer WE-LAN**



DATUM / DATE : 2018-10-15

H Schaltbild / Schematics :

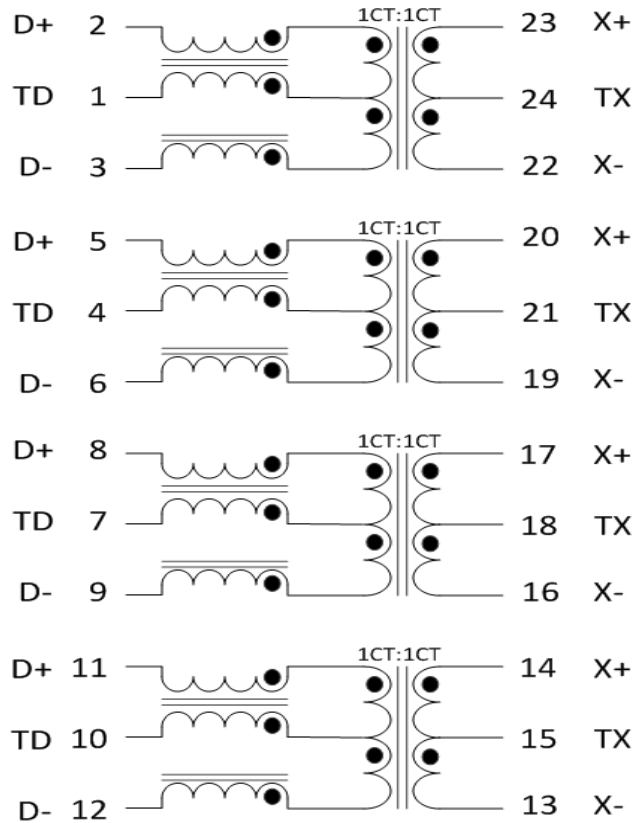

Freigabe erteilt / general release:	Kunde / customer		
.....	JaB	Revision 05 2018-10-15
Datum / date	Unterschrift / signature	JaB	Revision 04 2015-01-26
.....	LuRa	Revision 03 2014-07-28
	Würth Elektronik	LuRa	Revision 02 2014-01-20
.....	Mle	Revision 01 2013-04-22
Geprüft / checked	Kontrolliert / approved	Mle	Revision 00 2012-11-09
		Name	Änderung / modification Datum / date

Würth Elektronik eiSos GmbH & Co.KG

D-74638 Waldenburg · Max-Eyth-Straße 1 - 3 · Germany · Telefon (+49) (0) 7942 - 945 - 0 · Telefax (+49) (0) 7942 - 945 - 400
<http://www.we-online.com>

Spezifikation für Freigabe / specification for release

Kunde / customer :
 Artikelnummer / part number : **749023010A**
 Bezeichnung : **LAN-Übertrager WE-LAN**
 description : **LAN-Transformer WE-LAN**



DATUM / DATE : 2018-10-15

I Rollenspezifikation / tape and reel specification :

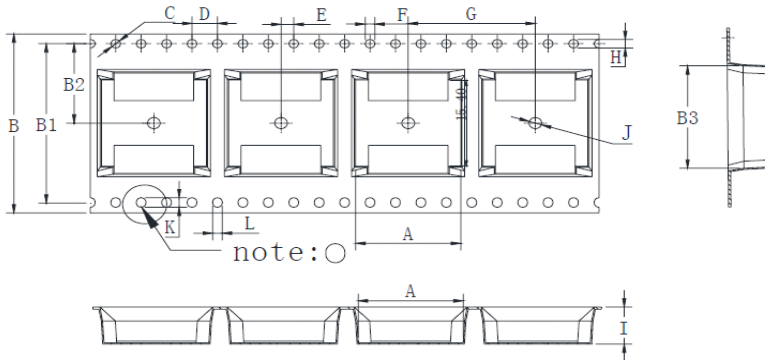

Gurtspezifikation / Tape specification:

A	16,50 ± 0,10	mm
B	32,00 ± 0,30	mm
B1	28,40 ± 0,10	mm
B2	14,20 ± 0,10	mm
B3	17,93 ± 0,10	mm
C	1,50 + 0,10/-0	mm
D	4,00 ± 0,10	mm
E	2,00 ± 0,10	mm
F	1,50 + 0,10/-0	mm
G	20,00 ± 0,10	mm
H	1,50 + 0,10/-0	mm
I	6,60 ± 0,10	mm
J	2,00 + 0,10/-0	mm
K	1,70 + 0,10/-0	mm
L	1,50 + 0,10/-0	mm

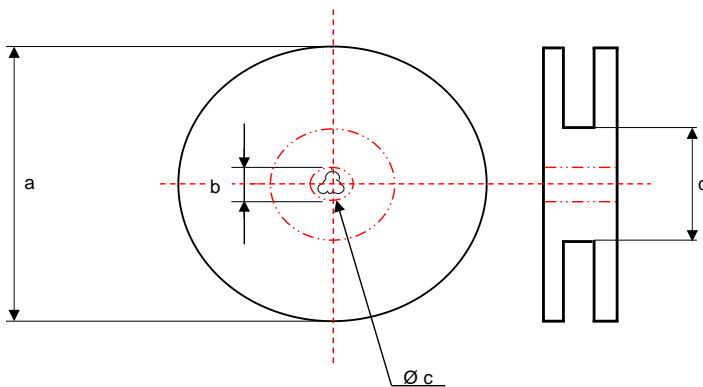

Rollenspezifikation / Reel specification:

a	330,0 ± 2,0	mm
b	21,00 ± 0,8	mm
c	13,50 ± 0,5	mm
d	100,0 ± 1,0	mm

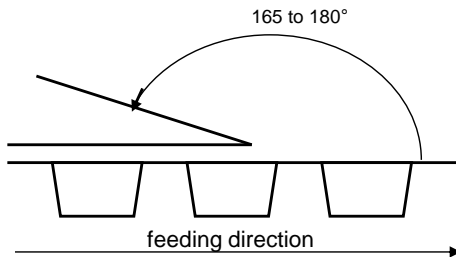

The force for tearing off cover tape is 40 to 120 grams in arrow direction

Packing quantity:
 400 pcs/reel
 4000 pcs/carton

Freigabe erteilt / general release:	Kunde / customer		
.....			
Datum / date	Unterschrift / signature		
.....	Würth Elektronik		
.....			
Geprüft / checked	Kontrolliert / approved		
.....			
	Name	Änderung / modification	Datum / date

This electronic component has been designed and developed for usage in general electronic equipment. Before incorporating the component into any equipment where higher safety and reliability is especially required or if there is the possibility of direct damage or injury to human body, for example in the range of aerospace, aviation, nuclear control, submarine, transportation, (automotive control, train control, ship control), transportation signal, disaster prevention, medical, public information network etc, Würth Elektronik eiSos GmbH must be informed before the design-in stage. In addition, sufficient reliability evaluation checks for safety must be performed on every electronic component which is used in electrical circuits that require high safety and reliability functions or performance.

Würth Elektronik eiSos GmbH & Co.KG

D-74638 Waldenburg · Max-Eyth-Straße 1 - 3 · Germany · Telefon (+49) (0) 7942 - 945 - 0 · Telefax (+49) (0) 7942 - 945 - 400
<http://www.we-online.com>

X-ON Electronics

Largest Supplier of Electrical and Electronic Components

Click to view similar products for [Audio Transformers](#) / [Signal Transformers](#) category:

Click to view products by [Wurth](#) manufacturer:

Other Similar products are found below :

[CX2041NLT](#) [MGPWT-00449-P](#) [PE-64961](#) [H1302FNLT](#) [H5008FNL](#) [H5012FNL](#) [H5020FNLT](#) [H5077NLT](#) [H5079NLT](#) [H5084FNLT](#)
[B78476A9558A003](#) [1812WBT2-4](#) [1879479-1](#) [HX2260FNL](#) [HX5014FNL](#) [EX2024FNL](#) [FL1066](#) [T1137NLT](#) [T3012NL](#) [PE-65812FNL](#) [PE-65848FNLT](#) [H1174FNL](#) [H1302FNL](#) [H5015FNL](#) [H5019EFNL](#) [H5062FNLT](#) [CX2047LNL](#) [MGPWT-00059-P](#) [MGPWT-00266-P](#) [MGPWT-00278-P](#) [MGPWT-00431-P](#) [TTC-100](#) [TTC-143-H](#) [TTC-5032-1](#) [BX1194WNLT](#) [HX1234NLT](#) [HX5008FNLT](#) [HX5019FNL](#) [HX5084NL](#) [3-1879385-5](#) [TX1263NLT](#) [4-1879391-0](#) [T1142NL](#) [HX6101FNL](#) [HX5084FNL](#) [HX1148NL](#) [HX5020FNLT](#) [HX5014FNLT](#) [T1124NL](#)
[1879732-1](#)