

SOLDER SUFFIX	CUSTOMER TERMINAL	RoHS	LEAD(Pb)-FREE	(8F)(8K)
LF3	Sn100%	Yes	Yes	

(8L) * DIMENSION MAY BE EXCEEDED WITH SOLDER ONLY

(7X)(6T) PART MUST INSERT FULLY TO SURFACE A IN RECOMMENDED GRID .025 SQ.(4) [.64]

(6T)(7M) .110/.140 * [2.79/3.56]

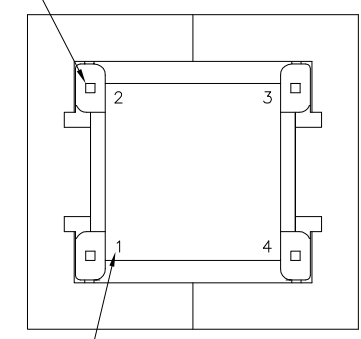

TERM. NO.'s FOR REF. ONLY

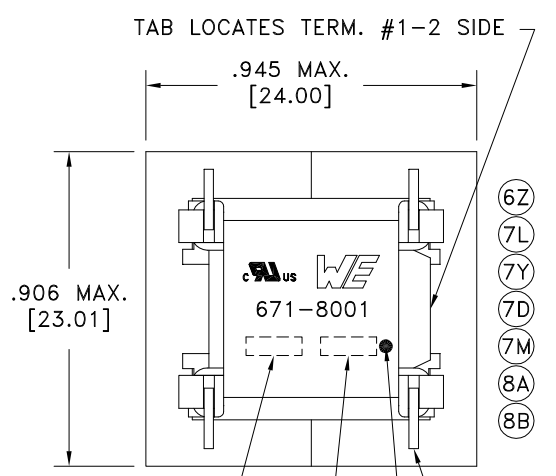
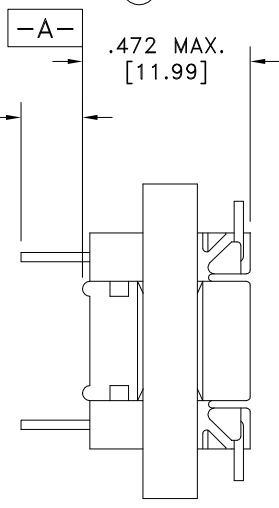

LOT CODE & DATE CODE (8K)

(8F) SOLDER SUFFIX

DOT LOCATES TERM. #1 *

TERM 1

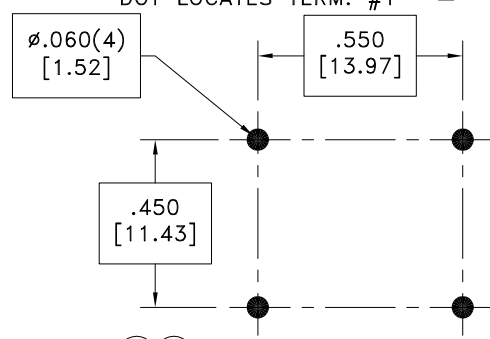

(7X)(6T) RECOMMENDED P.C. PATTERN, COMPONENT SIDE

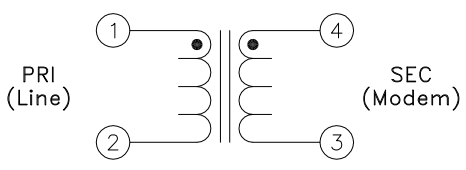

ELECTRICAL SPECIFICATIONS @ 25°C unless otherwise noted:

- IMPEDANCE: 600 ohms each, PRI & SEC (ref.). Designed to reflect 600 ohms on the PRI with 470 ohm load on SEC.
- (7Z) LONGITUDINAL BALANCE: 66dB min., 60 - 1000Hz; 46dB min., 1-2, 1000 - 4000Hz, per FCC part 68.310, with terminal 3 or 4 grounded.
- (7Z) D.C. RESISTANCE (@20°C): PRI, 108 ohms ±10%. SEC, 120 ohms ±10%.
- FREQUENCY RESPONSE: ±1.0dB, 600 - 3500Hz, ±4dB, 300 - 600Hz.
- INSERTION LOSS: 2.5dB max., 1000Hz, per IEEE method, 0/30mADC, 20°C.
- DIELECTRIC RATING: 1000VAC, 1 minute tested by applying 1250VAC for 1 second between PRI-SEC; PRI-Core. Meets or exceeds requirements of: CAN/CSA-C22.2 No.225 (M90); DOC's CS-03 (Issue 7); UL's UL1459, 2nd ED. (1992); and FCC's Part 68(58 FR 44907, Aug. 25, 1993).
- (6T)(7G)(7K)(7Q)(7R)
- (7Z) TURNS RATIO: (PRI):(SEC) = 1:1, ±2%.
- OPERATING CONDITIONS: All spec. except as noted to be from -20 to +4dBm, 0/100mADC in PRI, 600 ohm source resistance on PRI 470 ohm load on SEC.

(7X)* Marking Detail may be rotated 90° clockwise. Locating Dot will NOT move. Midcom p/n 671-8001-LF3 is eiSos p/n: 7500718001.

- (8J) OPERATING TEMPERATURE RANGE: -40°C to +85°C.
- (8K) Wire insulation & RoHS status not affected by wire color.
- (8K) Wire insulation color may vary depending on availability.

DETAILS SUBJECT TO CHANGE

(7K)(8K)	
AGENCY NUMBER	
(8H) UL	E205930

Unless otherwise specified:
Tolerances:
Angles: ±1°
Fractions: ±1/64
Decimals: ±.005[.13]

This drawing is dual dimensioned.
Dimensions in brackets are in millimeters.

DRAWING TITLE
TRANSFORMER
DC COUPLING (8G)
eiSos p/n: 7500718001



PART NO. (8K)(8F) REV. 8L
671-8001-LF3 4/16

PART# 671-8001-LF3

X-ON Electronics

Largest Supplier of Electrical and Electronic Components

Click to view similar products for [Audio Transformers](#) / [Signal Transformers](#) category:

Click to view products by [Würth](#) manufacturer:

Other Similar products are found below :

[CX2041NLT](#) [MGPWT-00449-P](#) [PE-64961](#) [H1302FNLT](#) [H5008FNL](#) [H5012FNL](#) [H5020FNLT](#) [H5077NLT](#) [H5079NLT](#) [H5084FNLT](#)
[B78476A9558A003](#) [1812WBT2-4](#) [1879479-1](#) [HX2260FNL](#) [HX5014FNL](#) [EX2024FNL](#) [FL1066](#) [T1137NLT](#) [T3012NL](#) [PE-65812FNL](#) [PE-65848FNLT](#) [H1174FNL](#) [H1302FNL](#) [H5015FNL](#) [H5019EFNL](#) [H5062FNLT](#) [CX2047LNL](#) [MGPWT-00059-P](#) [MGPWT-00266-P](#) [MGPWT-00278-P](#) [MGPWT-00431-P](#) [TTC-100](#) [TTC-143-H](#) [TTC-5032-1](#) [BX1194WNLT](#) [HX1234NLT](#) [HX5008FNLT](#) [HX5019FNL](#) [HX5084NL](#) [3-1879385-5](#) [TX1263NLT](#) [4-1879391-0](#) [T1142NL](#) [HX6101FNL](#) [HX5084FNL](#) [HX1148NL](#) [HX5020FNLT](#) [HX5014FNLT](#) [T1124NL](#)
[1879732-1](#)