

General Description

The CD4049 provides six inverting buffers with high current output capability suitable for driving TTL or high capacitive loads. Since input voltages in excess of the buffers' supply voltage are permitted, the buffers may also be used to convert logic levels of up to 15V to standard TTL levels.

It operates over a recommended V_{DD} power supply range of 3V to 15V referenced to V_{SS} (usually ground). Unused inputs must be connected to V_{DD} , V_{SS} , or another input.

Features

- Wide supply voltage range from 3v to 15v
- Accepts input voltages in excess of the supply voltage
- 5V, 10V, and 15V parametric ratings
- Specified from -40°C to +105°C
- Packaging information: DIP16/SOP16/TSSOP16

ORDERING INFORMATION

DEVICE	Package Type	MARKING	Packing	Packing QTY
CD4049BE	DIP-16	CD4049BE	Tube	1000/Box
CD4049BDTR	SOP-16	CD4049B	Tape	2500/Reel
CD4049BDTR	TSSOP-16	CD4049B	Tape	3000/Reel

Block Diagram And Pin Description

Block Diagram

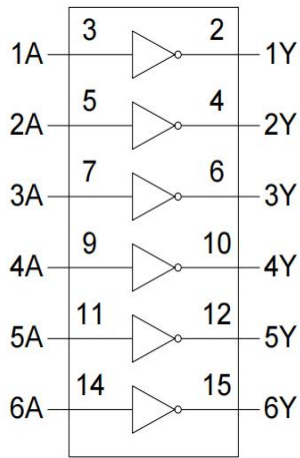

Figure 1. Functional symbol

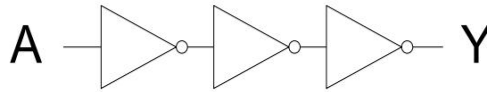

Figure 2. Logic diagram for one gate

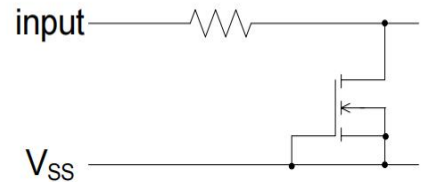

Figure 3. Input protection circuit

Pin Configurations

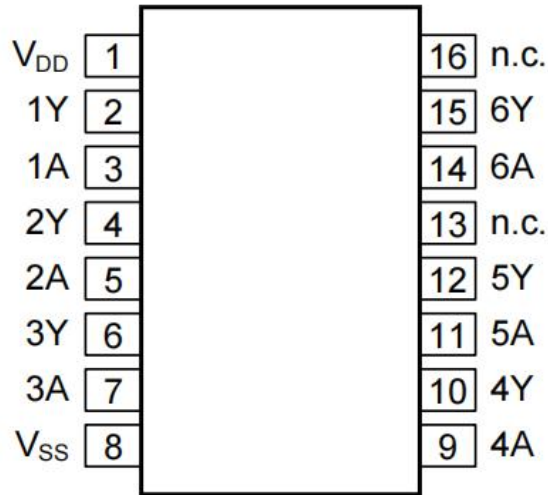

Figure 4. pin configuration

Pin Description

Pin No.	Pin Name	Description
1	V _{DD}	supply voltage
2	1Y	data output
3	1A	data input
4	2Y	data output
5	2A	data input
6	3Y	data output
7	3A	data input
8	V _{SS}	ground supply voltage
9	4A	data input
10	4Y	data output
11	5A	data input
12	5Y	data output
13	n.c.	not connected
14	6A	data input
15	6Y	data output
16	n.c.	not connected

Electrical Parameter

Absolute Maximum Ratings (T_{amb}=25°C, unless otherwise specified.)

Characteristic	Symbol	Conditions	Min.	Max.	Unit
supply voltage	V _{DD}	-	-0.5	+18	V
DC input current	I _{IK}	V _I < -0.5V	-10	-	mA
input voltage	V _I	-	-0.5	+18	V
output clamping current	I _{OK}	V _O < -0.5V or V _O > V _{DD} +0.5V	-	±10	mA
input/output current	I _{I/O}	-	-	±10	mA
supply current	I _{DD}	-	-	50	mA
storage temperature	T _{stg}	-	-65	+150	°C
soldering temperature	T _L	10s	DIP	245	°C
			SOP/TSSOP	260	°C

Recommended Operating Conditions

Parameter	Symbol	Conditions	Min.	Typ.	Max.	Unit
supply voltage	V _{DD}	-	3	-	15	V
input voltage	V _I	-	0	-	15	V
ambient temperature	T _{amb}	in free air	-40	-	+105	°C

Electrical Characteristics

DC Characteristics 1 (T_{amb}=25°C, voltages are referenced to V_{SS} (ground=0V), unless otherwise specified.)

Parameter	Symbol	Conditions(V)			T _{amb} =25°C			Unit
		V _O	V _{IN}	V _{DD}	Min.	Typ.	Max.	
supply current	I _{DD}	-	0, 5	5	-	-	4	μA
		-	0, 10	10	-	-	8	μA
		-	0, 15	15	-	-	16	μA
LOW-level output current	I _{OL}	0.4	0, 5	5	2.9	-	-	mA
		0.5	0, 10	10	10	-	-	mA
		1.5	0, 15	15	20	-	-	mA
HIGH-level output current	I _{OH}	4.6	0, 5	5	-	-	-0.44	mA
		2.5	0, 5	5	-	-	-1.4	mA
		9.5	0, 10	10	-	-	-1.1	mA
		13.5	0, 15	15	-	-	-3	mA
LOW-level output voltage	V _{OL}	-	0, 5	5	-	-	0.05	V
		-	0, 10	10	-	-	0.05	V
		-	0, 15	15	-	-	0.05	V
HIGH-level output voltage	V _{OH}	-	0, 5	5	4.95	-	-	V
		-	0, 10	10	9.95	-	-	V
		-	0, 15	15	14.95	-	-	V
LOW-level input voltage	V _{IL}	-	0, 5	5	-	-	1.5	V
		-	0, 10	10	-	-	3	V
		-	0, 15	15	-	-	4	V
HIGH-level input voltage	V _{IH}	-	0, 5	5	3.5	-	-	V
		-	0, 10	10	7	-	-	V
		-	0, 15	15	11	-	-	V
input leakage current	I _I	-	0, 15	15	-	-	±0.3	μA

DC Characteristics 2

($T_{amb}=-40^{\circ}\text{C}$ to $+105^{\circ}\text{C}$, voltages are referenced to V_{SS} (ground=0V), unless otherwise specified.)

Parameter	Symbol	Conditions(V)			$T_{amb}=-40^{\circ}\text{C}$		$T_{amb}=+105^{\circ}\text{C}$		Unit
		V_O	V_{IN}	V_{DD}	Min.	Max.	Min.	Max.	
supply current	I_{DD}	-	0, 5	5	-	4	-	30	μA
		-	0, 10	10	-	8	-	60	μA
		-	0, 15	15	-	16	-	120	μA
LOW-level output current	I_{OL}	0.4	0, 5	5	3.5	-	2.3	-	mA
		0.5	0, 10	10	12	-	8	-	mA
		1.5	0, 15	15	24	-	16	-	mA
HIGH-level output current	I_{OH}	4.6	0, 5	5	-	-0.52	-	-0.36	mA
		2.5	0, 5	5	-	-1.7	-	-1.1	mA
		9.5	0, 10	10	-	-1.3	-	-0.9	mA
		13.5	0, 15	15	-	-3.6	-	-2.4	mA
LOW-level output voltage	V_{OL}	-	0, 5	5	-	0.05	-	0.05	V
		-	0, 10	10	-	0.05	-	0.05	V
		-	0, 15	15	-	0.05	-	0.05	V
HIGH-level output voltage	V_{OH}	-	0, 5	5	4.95	-	4.95	-	V
		-	0, 10	10	9.95	-	9.95	-	V
		-	0, 15	15	14.95	-	14.95	-	V
LOW-level input voltage	V_{IL}	-	0, 5	5	-	1.5	-	1.5	V
		-	0, 10	10	-	3	-	3	V
		-	0, 15	15	-	4	-	4	V
HIGH-level input voltage	V_{IH}	-	0, 5	5	3.5	-	3.5	-	V
		-	0, 10	10	7	-	7	-	V
		-	0, 15	15	11	-	11	-	V
input leakage current	I_I	-	0, 15	15	-	± 0.3	-	± 1.0	μA

AC Characteristics ($T_{amb}=25^{\circ}\text{C}$, $V_{SS}=0\text{V}$; $C_L=50\text{pF}$; $t_r=t_f\leq 20\text{ns}$, unless otherwise specified.)

Parameter	Symbol	Conditions	DD	Min.	Typ.	Max.	Unit
HIGH to LOW propagation delay	t_{PHL}	nA to nY; see Figure 6	5	-	35	70	ns
			10	-	15	30	ns
			15	-	12	25	ns
LOW to HIGH propagation delay	t_{PLH}	nA to nY; see Figure 6	5	-	50	100	ns
			10	-	25	50	ns
			15	-	20	40	ns
HIGH to LOW output transition time	t_{THL}	see Figure 6	5	-	20	40	ns
			10	-	10	20	ns
			15	-	7	14	ns
LOW to HIGH output transition time	t_{TLH}	see Figure 6	5	-	60	120	ns
			10	-	30	60	ns
			15	-	20	40	ns

Testing Circuit

AC Testing Circuit

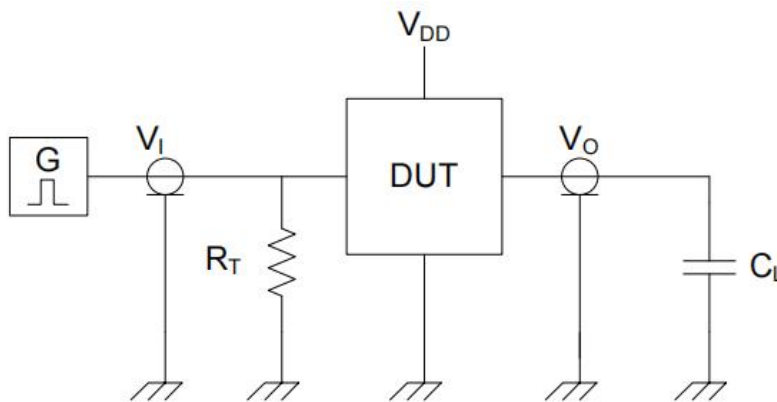

Figure 5. Test circuit for measuring switching times

Definitions for test circuit:

C_L =Load capacitance including jig and probe capacitance.

R_T =Termination resistance should be equal to the output impedance Z_o of the pulse generator.

AC Testing Waveforms

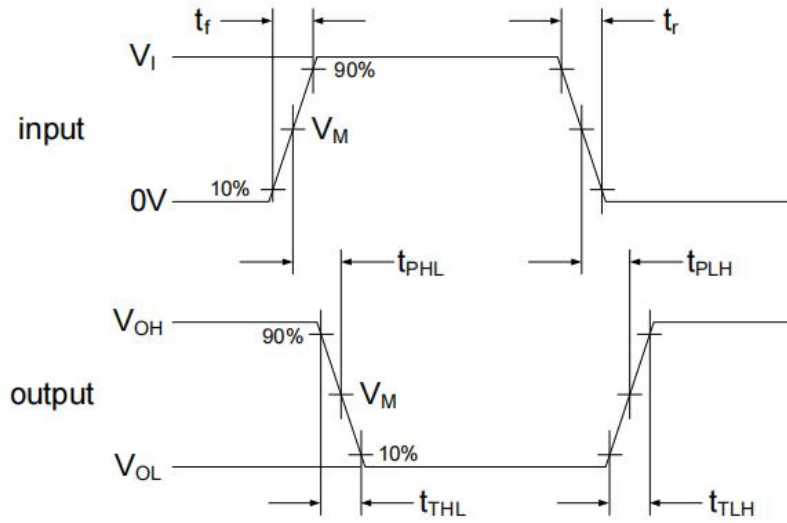

Figure 6. Input (nA) to output (nY) propagation delays and transition times

Measurement Points

Input		Output		
V_M	V_I	V_M	V_X	V_Y
$0.5 \times V_{DD}$	0V to V_{DD}	$0.5 \times V_{DD}$	$0.1 \times V_{DD}$	$0.9 \times V_{DD}$

Test Data

Supply voltage	Input			Load
V_{DD}	V_I	V_M	t_r, t_f	C_L
5V to 15V	V_{DD}	$0.5 \times V_I$	$\leq 20\text{ns}$	50pF

Package Information

DIP16

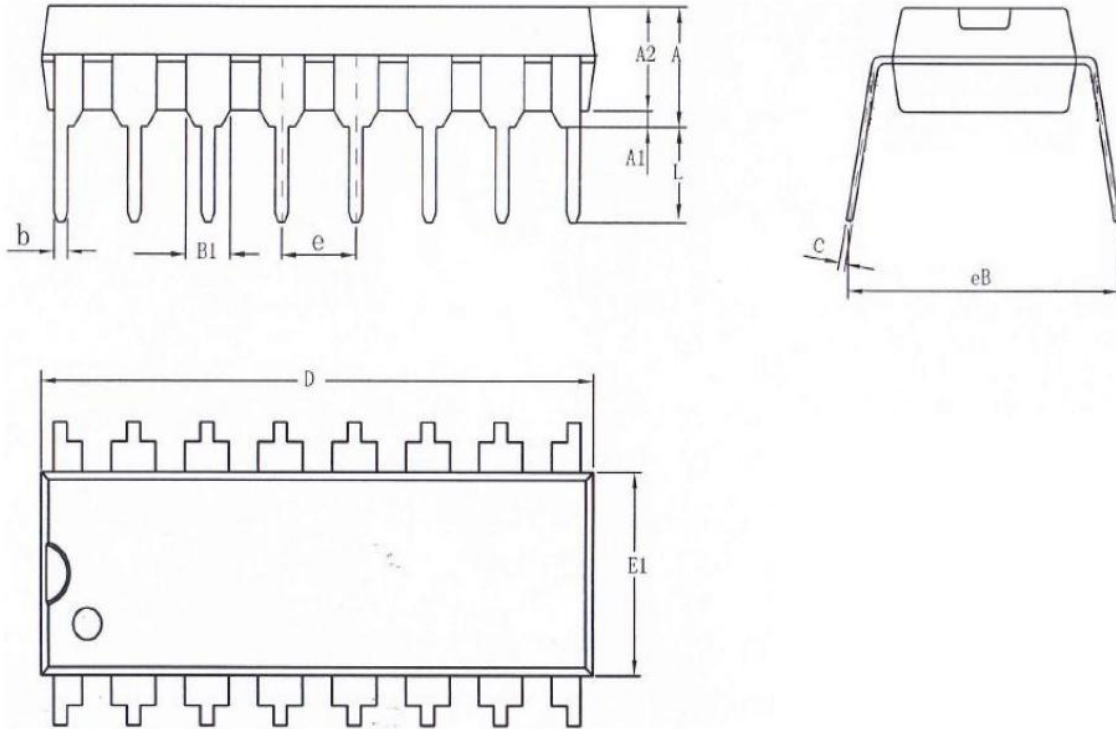

Symbol	Dimensions(mm)	
	Min.	Max.
A2	3.20	3.60
A1	0.51	-
A	3.60	5.33
L	3.00	3.60
b	0.36	0.56
B1	1.52	
D	18.80	19.94
E1	6.20	6.60
e	2.54	
c	0.20	0.36
eB	7.62	9.30

SOP16

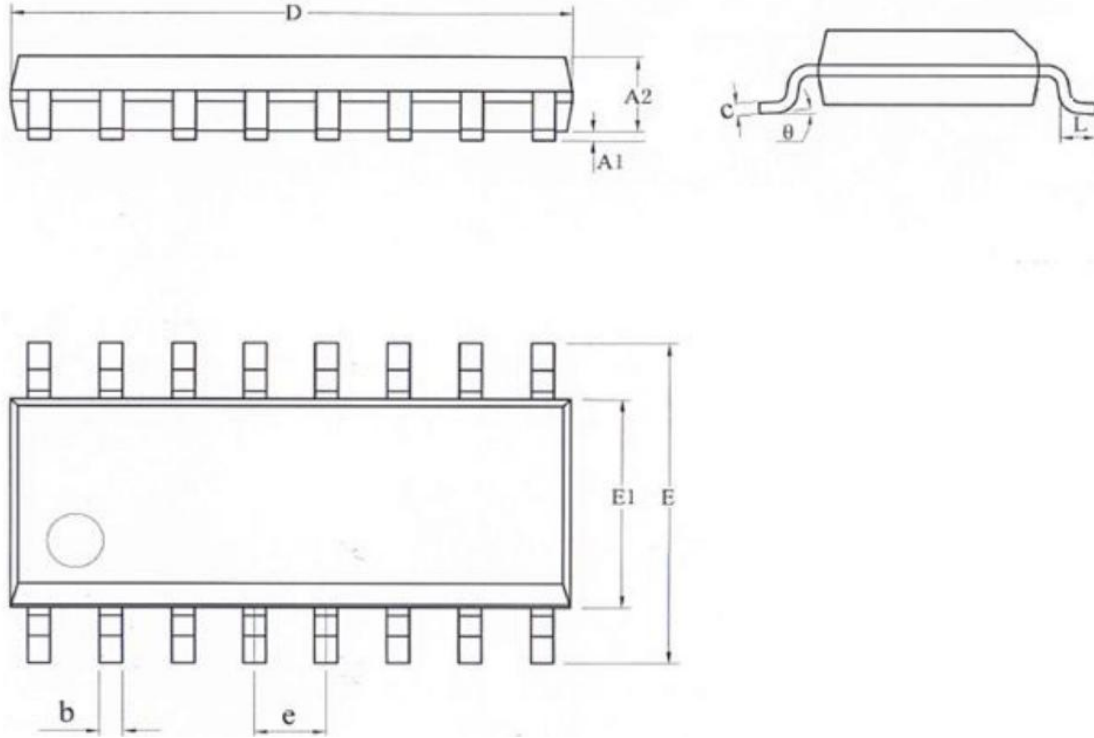

Symbol	Dimensions (mm)	
	Min.	Max.
A1	0.10	0.25
A2	1.25	1.55
b	0.33	0.51
c	0.19	0.25
D	9.50	10.10
E	5.80	6.30
E1	3.70	4.10
e	1.27	
L	0.35	0.89
θ	0°	8°

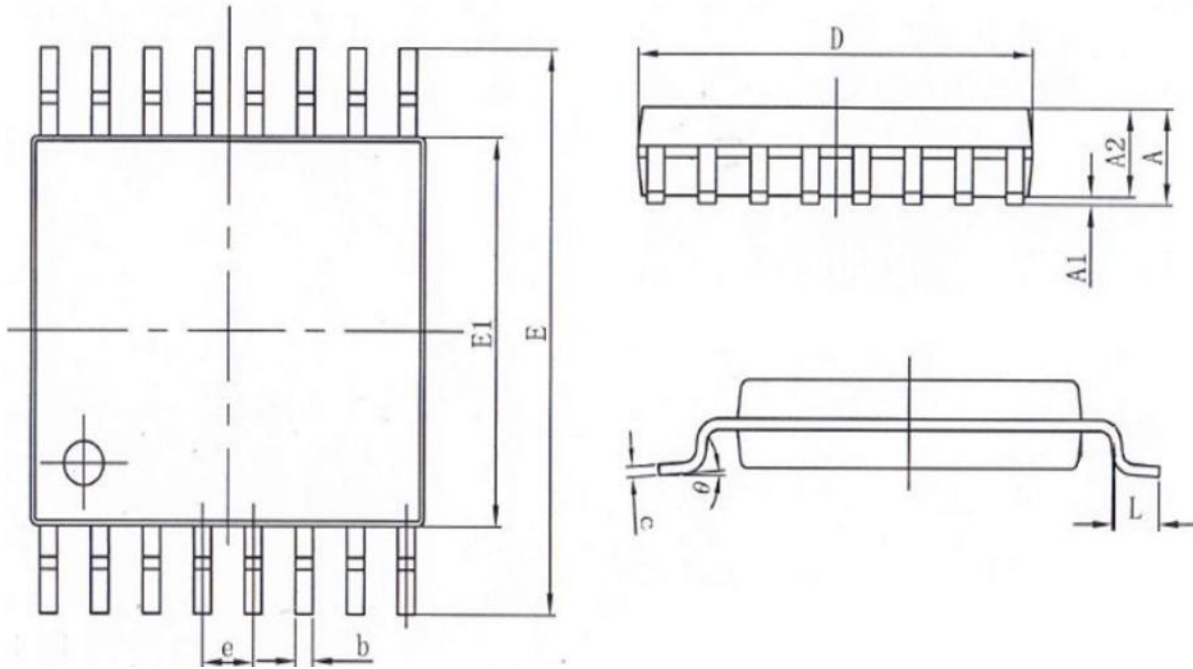

SYMBOL	MILLIMETER	
	MIN	MAX
A	-	1.20
A1	0.05	0.15
A2	0.80	1.05
b	0.19	0.30
c	0.09	0.20
D	4.90	5.10
E1	4.30	4.50
E	6.20	6.60
e	0.65	
L	0.45	0.75
θ	0°	8°

Statements And Notes



Part name	Hazardous substances or Elements									
	Lead and lead compounds	Mercury and mercury compounds	Cadmium and cadmium compounds	Hexavalent chromium compounds	Polybrominated biphenyls	Polybrominated biphenyl ethers	Dibutyl phthalate	Butyl benzyl phthalate	Di-2-ethylhexyl phthalate	Diisobutyl phthalate
Lead frame	○	○	○	○	○	○	○	○	○	○
Plastic resin	○	○	○	○	○	○	○	○	○	○
Chip	○	○	○	○	○	○	○	○	○	○
The lead	○	○	○	○	○	○	○	○	○	○
Plastic sheet installed	○	○	○	○	○	○	○	○	○	○
explanation	○: Indicates that the content of hazardous substances or elements in the detection limit of the following the SJ/T11363-2006 standard. ×: Indicates that the content of hazardous substances or elements exceeding the SJ/T11363-2006 Standard limit requirements									

Statement:

- ✧ Shenzhen xinbole electronics co., ltd. reserves the right to change the product specifications, without notice!
Before placing an order, the customer needs to confirm whether the information obtained is the latest version, and verify the integrity of the relevant information.
- ✧ Any semiconductor product is liable to fail or malfunction under certain conditions, and the buyer shall be responsible for complying with safety standards in the system design and whole machine manufacturing using Shenzhen xinbole electronics co., ltd products, and take appropriate security measures to avoid the potential risk of failure may result in personal injury or property losses of the situation occurred!
- ✧ Product performance is never ending, Shenzhen xinbole electronics co., ltd will be dedicated to provide customers with better performance, better quality of integrated circuit products.

X-ON Electronics

Largest Supplier of Electrical and Electronic Components

Click to view similar products for [Buffers & Line Drivers](#) category:

Click to view products by [XBLW](#) manufacturer:

Other Similar products are found below :

[LXV200-024SW](#) [74AUP2G34FW3-7](#) [HEF4043BP](#) [NL17SG125DFT2G](#) [NLU1GT126CMUTCG](#) [CD4041UBE](#) [54FCT240CTDB](#)

[74HCT540N](#) [DS14C88N](#) [070519XB](#) [NL17SZ07P5T5G](#) [74LVC2G17FW4-7](#) [CD4502BE](#) [5962-8982101PA](#) [NL17SH17P5T5G](#)

[74HCT126T14-13](#) [74VHC9126FT\(BJ\)](#) [RHRXH162244K1](#) [74AUP1G34FW5-7](#) [74AUP1G07FW5-7](#) [74LVC1G126FW4-7](#)

[74LVC2G126RA3-7](#) [74LVCE1G125FZ4-7](#) [74AUP1G126FW5-7](#) [54FCT240TLB](#) [74LVCE1G07FZ4-7](#) [NLX3G16DMUTCG](#)

[NLX2G06AMUTCG](#) [LE87100NQCT](#) [LE87285NQC](#) [LE87290YQC](#) [LE87290YQCT](#) [74AUP1G125FW5-7](#) [NLU2G16CMUTCG](#)

[MC74LCX244MN2TWG](#) [NL17SG17P5T5G](#) [NLV74HC125ADR2G](#) [NLVHCT245ADTR2G](#) [NLVVHC1G126DFT2G](#) [EL5623IRZ](#)

[ISL15102AIRZ-T13](#) [ISL1539IRZ-T13](#) [MC100EP17MNG](#) [MC74HCT365ADR2G](#) [MC74LCX244ADTR2G](#) [NL27WZ126US](#) [NL37WZ16US](#)

[NLU1G07MUTCG](#) [NLU2G07MUTCG](#) [NLX3G17BMX1TCG](#)