



General Description

CD4060 is a 14-stage ripple-carry binary counter/divider and oscillator with three oscillator terminals (RS, REXT and CEXT), ten buffered outputs (Q3 to Q9 and Q11 to Q13) and an overriding asynchronous master reset input (MR).

The oscillator configuration allows design of either RC or crystal oscillator circuits. The oscillator may be replaced by an external clock signal at input RS. The counter advances on the negative -going transition of RS. A HIGH level on MR resets the counter (Q3 to Q9 and Q11 to Q13=LOW), independent of other input conditions.

It operates over a recommended V_{DD} power supply range of 3V to 15V referenced to V_{SS} (usually ground). Unused inputs must be connected to V_{DD} , V_{SS} , or another input.

Features

- Wide supply voltage range from 3V to 15V
- Tolerant of slow clock rise and fall times
- Fully static operation
- 5V, 10V, and 15V parametric ratings
- Standardized symmetrical output characteristics
- Inputs and outputs are protected against electrostatic effects
- Specified from -40°C to +85°C
- Packaging information: DIP16/SOP16/TSSOP16

Ordering Information

Product Model	Package Type	Marking	Packing	Packing Qty
CD4060BE	DIP-16	CD4060BE	Tube	1000/Box
CD4060BDTR	SOP-16	CD4060B	Tape	2500/Reel
CD4060BDTR	TSSOP-16	CD4060B	Tape	3000/Reel

2、Block Diagram And Pin Description

2.1、Block Diagram

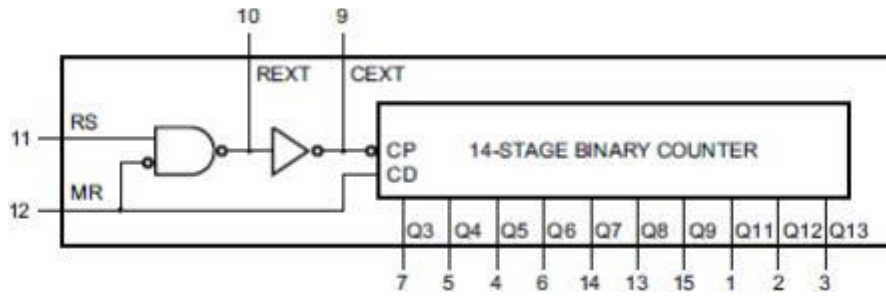

Figure 1. Functional diagram

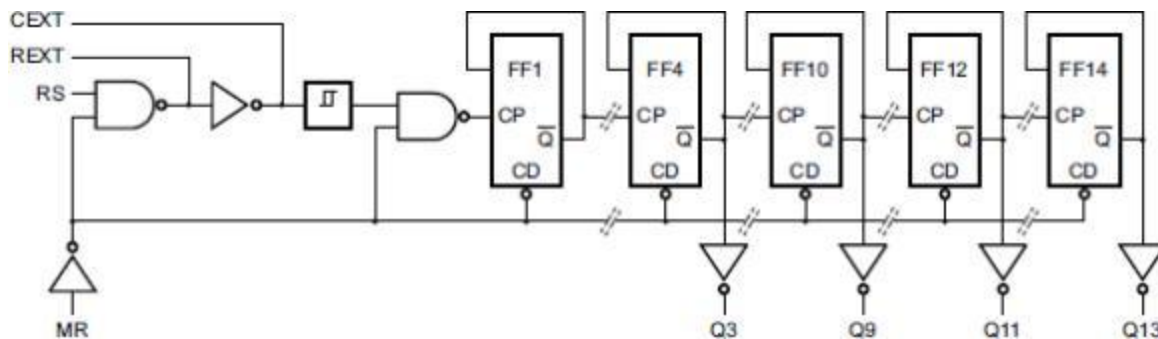
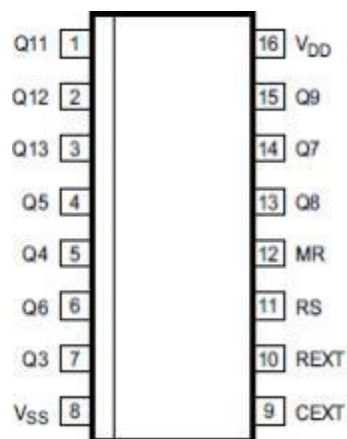

Figure 2. Logic diagram

2.2、Pin Configurations



2.3 、 Pin Description

Pin No.	Pin Name	Description
1	Q11	counter output
2	Q12	counter output
3	Q13	counter output
4	Q5	counter output
5	Q4	counter output
6	Q6	counter output
7	Q3	counter output
8	V _{SS}	ground (0V)
9	CEXT	external capacitor connection
10	REXT	oscillator pin
11	RS	clock input/oscillator pin
12	MR	master reset
13	Q8	counter output
14	Q7	counter output
15	Q9	counter output
16	V _{DD}	supply voltage

2.4 、 Function Table

Input		Output
RS	MR	Q3 to Q9 and Q11 to Q13
t	L	no change
↓	L	count
X	H	L

Note: H=HIGH voltage level; L=LOW voltage level; X=don't care; t=LOW-to-HIGH clock transition.

3 Electrical Parameter

3.1 、 Absolute Maximum Ratings

(Voltages are referenced to V_{SS} (ground=0V), unless otherwise specified.)

Parameter	Symbol	Conditions	Min.	Max.	Unit
supply voltage	V _{DD}	-	-0.5	+18	V
DC input current	I _{IK}	any one input	-	±10	mA
input voltage	V _I	all inputs	-0.5	V _{DD} +0.5	V
storage temperature	T _{stg}	-	-65	+150	°C
total power dissipation	P _{tot}	-	-	500	mW
device dissipation	P	per output transistor	-	100	mW
Soldering temperature	T _L	10s	DIP	245	°C
			SOP	250	°C

Note:

[1] For DIP16 packages: above 70°C the value of P_{tot} derates linearly with 12mW/K.

[2] For SOP16 packages: above 70°C the value of P_{tot} derates linearly with 8mW/K.

[3] For (T)SSOP16 packages: above 60°C the value of P_{tot} derates linearly with 5.5mW/K.

3.2 、 Recommended Operating Conditions

Parameter	Symbol	Conditions	Min.	Typ.	Max.	Unit	
supply voltage	V_{DD}	-	3	-	15	V	
ambient temperature	T_{amb}	in free air	-40	-	+85	°C	
input pulse width	t_w	$f=100kHz$	$V_{DD}=5V$	100	-	-	ns
			$V_{DD}=10V$	40	-	-	ns
			$V_{DD}=15V$	30	-	-	ns
input pulse rise and fall time	t_{rIN}, t_{fIN}	$V_{DD}=5V$	unlimited			-	
		$V_{DD}=10V$				-	
		$V_{DD}=15V$				-	
input pulse frequency	f_{RS}	external pulse source	$V_{DD}=5V$	-	-	3.5	MHz
			$V_{DD}=10V$	-	-	8	MHz
			$V_{DD}=15V$	-	-	12	MHz
reset pulse width	t_{wR}	$V_{DD}=5V$	120	-	-	ns	
		$V_{DD}=10V$	60	-	-	ns	
		$V_{DD}=15V$	40	-	-	ns	

3.1 、 Absolute Maximum Ratings

 (Voltages are referenced to V_{SS} (ground=0V), unless otherwise specified.)

Parameter	Symbol	Conditions	Min.	Max.	Unit	
supply voltage	V_{DD}	-	-0.5	+18	V	
DC input current	I_{IK}	any one input	-	±10	mA	
input voltage	V_I	all inputs	-0.5	$V_{DD}+0.5$	V	
storage temperature	T_{stg}	-	-65	+150	°C	
total power dissipation	P_{tot}	-	-	500	mW	
device dissipation	P	per output transistor	-	100	mW	
Soldering temperature	T_L	10s	DIP	245		°C
			SOP	250		°C

Note:

 [1] For DIP16 packages: above 70°C the value of P_{tot} derates linearly with 12mW/K.

 [2] For SOP16 packages: above 70°C the value of P_{tot} derates linearly with 8mW/K.

 [3] For (T)SSOP16 packages: above 60°C the value of P_{tot} derates linearly with 5.5mW/K.

3.2 、 Recommended Operating Conditions

Parameter	Symbol	Conditions	Min.	Typ.	Max.	Unit	
supply voltage	V_{DD}	-	3	-	15	V	
ambient temperature	T_{amb}	in free air	-40	-	+85	°C	
input pulse width	t_w	$f=100kHz$	$V_{DD}=5V$	100	-	-	ns
			$V_{DD}=10V$	40	-	-	ns
			$V_{DD}=15V$	30	-	-	ns
input pulse rise and fall time	t_{rIN}, t_{fIN}	$V_{DD}=5V$	unlimited			-	
		$V_{DD}=10V$				-	
		$V_{DD}=15V$				-	
input pulse frequency	f_{RS}	external pulse source	$V_{DD}=5V$	-	-	3.5	MHz
			$V_{DD}=10V$	-	-	8	MHz
			$V_{DD}=15V$	-	-	12	MHz
reset pulse width	t_{wR}	$V_{DD}=5V$	120	-	-	ns	
		$V_{DD}=10V$	60	-	-	ns	
		$V_{DD}=15V$	40	-	-	ns	



LOW-level output voltage	V_{OL}	-	0, 5	5	-	0.05	-	0.05	V
		-	0, 10	10	-	0.05	-	0.05	V
		-	0, 15	15	-	0.05	-	0.05	V
HIGH-level output voltage	V_{OH}	-	0, 5	5	4.95	-	4.95	-	V
		-	0, 10	10	9.95	-	9.95	-	V
		-	0, 15	15	14.95	-	14.95	-	V
LOW-level input voltage	V_{IL}	0.5, 4.5	-	5	-	1.5	-	1.5	V
		1, 9	-	10	-	3	-	3	V
		1.5, 13.5	-	15	-	4	-	4	V
HIGH-level input voltage	V_{IH}	0.5, 4.5	-	5	3.5	-	3.5	-	V
		1, 9	-	10	7	-	7	-	V
		1.5, 13.5	-	15	11	-	11	-	V
input leakage current	I_I	-	0, 15	15	-	± 0.1	-	± 1	μA

3.3.3 AC Characteristics 1

 ($T_{amb}=25^{\circ}C$, $V_{SS}=0V$, t_r , $t_f=20ns$, $C_L=50pF$, $R_L=200k\Omega$, unless otherwise specified.)

Parameter	Symbol	Conditions	Min.	Typ.	Max.	Unit	
propagation delay time	t_{PHL}, t_{PLH}	RS to Q3 out; see Figure 4	$V_{DD}=5V$	-	370	740	ns
			$V_{DD}=10V$	-	150	300	ns
			$V_{DD}=15V$	-	100	200	ns
		Q _n to Q _{n+1} ; see Figure 4	$V_{DD}=5V$	-	100	200	ns
			$V_{DD}=10V$	-	50	100	ns
			$V_{DD}=15V$	-	40	80	ns
		MR to Q _n ; see Figure 4	$V_{DD}=5V$	-	180	360	ns
			$V_{DD}=10V$	-	80	160	ns
			$V_{DD}=15V$	-	50	100	ns
transition time	t_t	see Figure 4	$V_{DD}=5V$	-	100	200	ns
			$V_{DD}=10V$	-	50	100	ns
			$V_{DD}=15V$	-	40	80	ns
pulse width	t_w	minimum width; f=100kHz; RS HIGH;	$V_{DD}=5V$	-	50	100	ns
			$V_{DD}=10V$	-	20	40	ns
			$V_{DD}=15V$	-	15	30	ns
		minimum width; MR HIGH; see Figure 4	$V_{DD}=5V$	-	60	120	ns
			$V_{DD}=10V$	-	30	60	ns
			$V_{DD}=15V$	-	20	40	ns
input pulse rise and fall time	t_{rIN}, t_{fIN}	-	$V_{DD}=5V$	unlimited			-
			$V_{DD}=10V$	unlimited			-
			$V_{DD}=15V$	unlimited			-
maximum clock frequency	f_{max}	input RS; see Figure 4	$V_{DD}=5V$	3.5	7	-	MHz
			$V_{DD}=10V$	8	16	-	MHz
			$V_{DD}=15V$	12	24	-	MHz
input capacitance	C_I	any input	-	5	7.5	pF	

 Note: t_t is the same as t_{TLH} and t_{THL} .

4、Testing Circuit

4.1、AC Testing Circuit

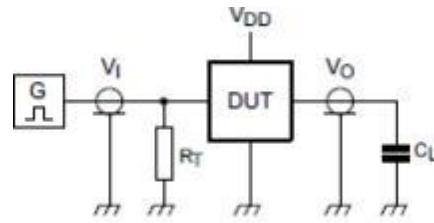

Figure 3. Test circuit for switching times

Definitions for test circuit:

DUT=Device Under Test.

C_L =Load capacitance including jig and probe capacitance.

R_T =Termination resistance should be equal to the output impedance Z_o of the pulse generator.

4.2、AC Testing Waveforms

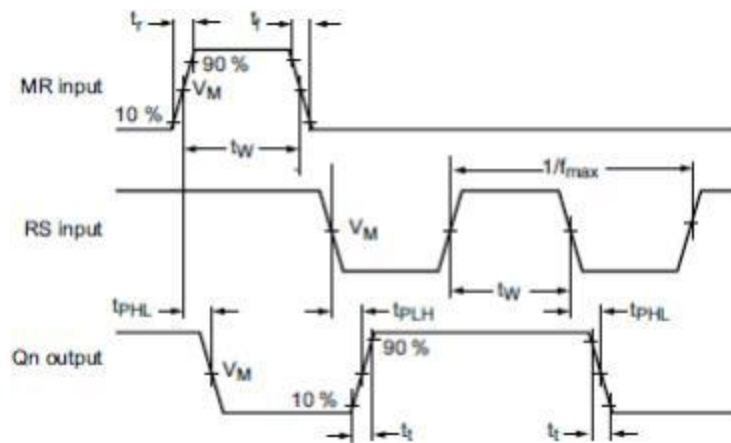

Figure 4. Waveforms showing propagation delays

4.3、Measurement Points

Supply voltage	Input	Output
V_{DD}	V_M	V_M
5V to 15V	$0.5 \times V_{DD}$	$0.5 \times V_{DD}$

4.4、Test Data

Supply voltage	Input		Load
V_{DD}	V_I	t_r, t_f	C_L
5V to 15V	V_{SS} or V_{DD}	$\leq 20\text{ns}$	50pF

5、Package Information

5.1 DIP16

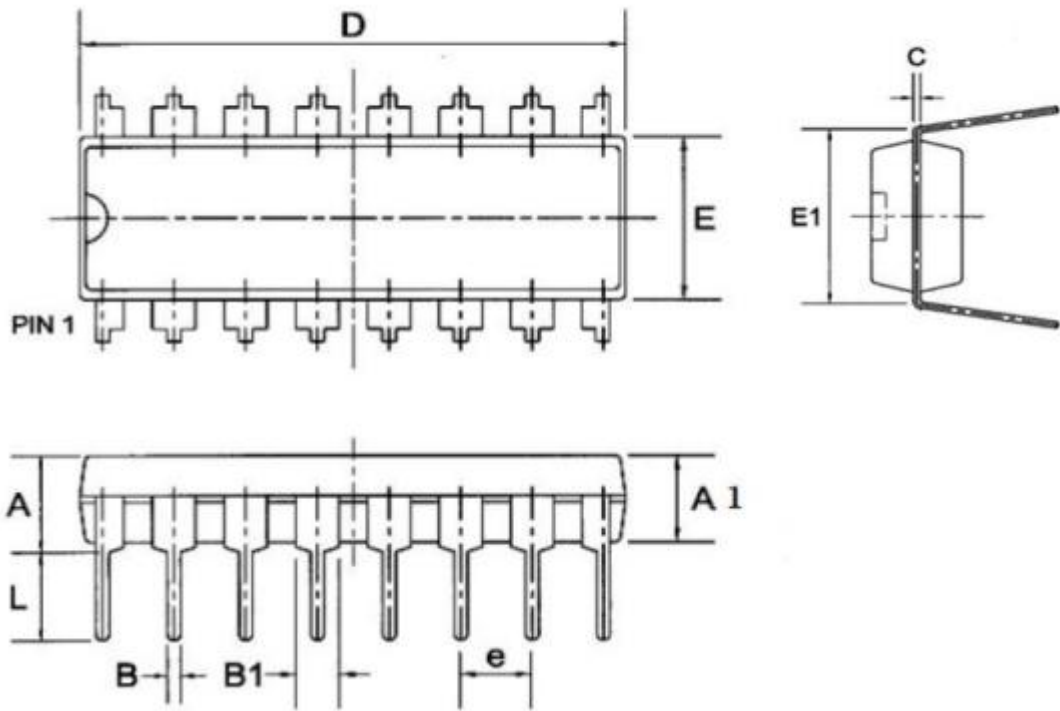

Symbol	Dimensions in Millimeters		
	Min	Nom	Max
A	--	--	4.31
A1	3.15	3.30	3.65
B	--	0.50	--
B1	--	1.6	--
C	--	0.27	--
D	19.00	19.20	19.60
E	6.20	6.50	6.60
E1	--	8.0	--
e	--	2.3	--
L	3.00	3.20	3.60

5.2 SOP16

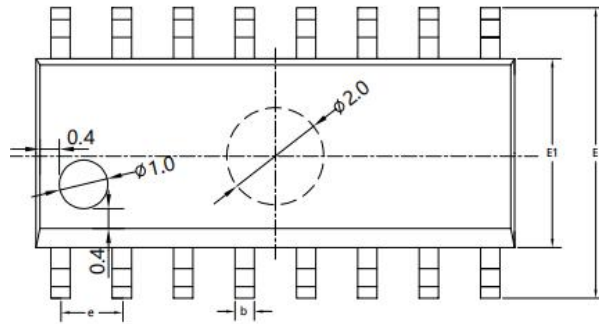
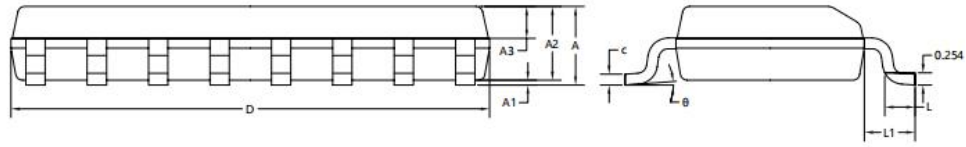

SYMBOL	MILLIMETER		
	MIN	NOM	MAX
A	1.50	1.60	1.70
A1	0.10	0.15	0.25
A2	1.40	1.45	1.50
A3	0.60	0.65	0.70
b	0.30	0.40	0.50
c	0.15	0.20	0.25
D	9.80	9.90	10.00
E	5.80	6.00	6.20
E1	3.85	3.90	3.95
e	1.27BSC		
L	0.50	0.60	0.70
L1	1.05BSC		
θ	0°	4°	8°

5.3 TSSOP16

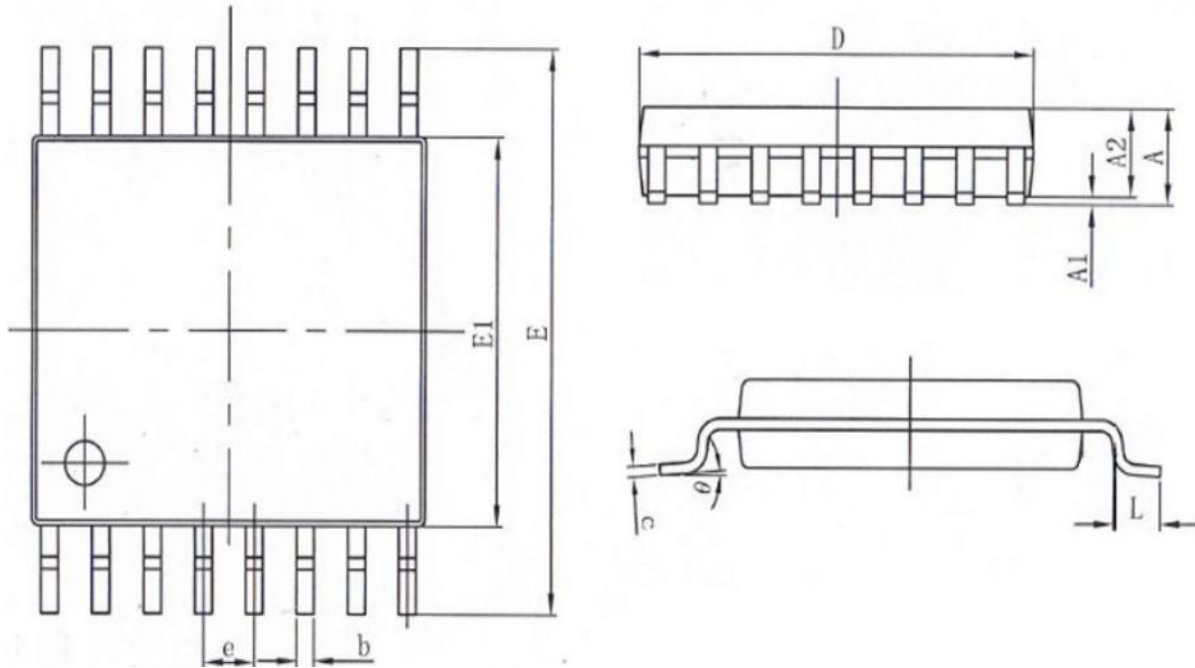

SYMBOL	MILLIMETER	
	MIN	MAX
A	-	1.20
A1	0.05	0.15
A2	0.80	1.05
b	0.19	0.30
c	0.09	0.20
D	4.90	5.10
E1	4.30	4.50
E	6.20	6.60
e	0.65	
L	0.45	0.75
θ	0°	8°

Statement:

- ✧ Shenzhen xinbole electronics co., ltd. reserves the right to change the product specifications, without notice! Before placing an order, the customer needs to confirm whether the information obtained is the latest version, and verify the integrity of the relevant information.
- ✧ Any semiconductor product is liable to fail or malfunction under certain conditions, and the buyer shall be responsible for complying with safety standards in the system design and whole machine manufacturing using Shenzhen xinbole electronics co., ltd products, and take appropriate security measures to avoid the potential risk of failure may result in personal injury or property losses of the situation occurred!
- ✧ Product performance is never ending, Shenzhen xinbole electronics co., ltd will be dedicated to provide customers with better performance, better quality of integrated circuit products.

X-ON Electronics

Largest Supplier of Electrical and Electronic Components

Click to view similar products for [Counter ICs](#) category:

Click to view products by [XBLW](#) manufacturer:

Other Similar products are found below :

[CD4018BE](#) [CD4033BE](#) [CD4060BE](#) [CD4040BE](#) [NLV14040BDR2G](#) [RFDIP1607ALM9T21](#) [RFDIP1606L708D1T](#) [RFTIP2510T12A8Q1C](#)
[74HC161DT](#) [CD4028BM/TR](#) [CD4060DM/TR](#) [CD4022BE](#) [CD4060DMT/TR](#) [CD4060BMT/TR](#) [74HC192M/TR](#) [CD4020BMT/TR](#)
[74HC193M/TR](#) [CD4518BM/TR](#) [CD4060TA16.TB](#) [CD4060DE](#) [CD4017CN](#) [CD4017SA.TB](#) [CD4022BM/TR](#) [CD4022BMT/TR](#)
[CD4028BDRG](#) [CD4060BDRG](#) [CD4017DA.TB](#) [CD4520BDRG](#) [CD4520BM\(LX\)](#) [CD4518BM\(LX\)](#) [SN74HC393DR\(LX\)](#) [CD4060BM\(LX\)](#)
[CD4060BE\(LX\)](#) [SN74HC192N\(XBLW\)](#) [CD4040BM\(LX\)](#) [CD4026BM\(LX\)](#) [CD40103BDR\(LX\)](#) [SN74LS192DR\(LX\)](#) [SN74HC161DR \(LX\)](#)
[CD40193BE\(LX\)](#) [CD4060BDTR\(XBLW\)](#) [SN74LS393DR](#) [SN74LS193N\(LX\)](#) [SN74LS193DR\(LX\)](#) [CD4017BM\(LX\)](#) [CD40193BM\(LX\)](#)
[SN74LS192N\(LX\)](#) [SN74LS160N\(LX\)](#) [SN74LS161N\(LX\)](#) [CD4024BM\(LX\)](#)