

## General Description

The CD4072 provides the positive dual 4-input OR function. The outputs are fully buffered for highest noise immunity and pattern insensitivity of output impedance.

It operates over a recommended  $V_{DD}$  power supply range of 3V to 15V referenced to  $V_{SS}$  (usually ground). Unused inputs must be connected to  $V_{DD}$ ,  $V_{SS}$ , or another input.

## Features

- Wide supply voltage range from 3V to 15V
- Fully static operation
- 5V, 10V, and 15V parametric ratings
- Standardized symmetrical output characteristics
- Inputs and outputs are protected against electrostatic effects
- Specified from  $-40^{\circ}\text{C}$  to  $+105^{\circ}\text{C}$
- Packaging information: DIP14/SOP14/TSSOP14

## ORDERING INFORMATION

DEVICE	Package Type	MARKING	Packing	Packing QTY
CD4072BE	DIP-14	CD4072BE	Tube	1000/Box
CD4072BDTR	SOP-14	CD4072B	Tape	2500/Reel
CD4072BTDTR	TSSOP-14	CD4072B	Tape	3000/Reel

## Block Diagram And Pin Description

### Block Diagram

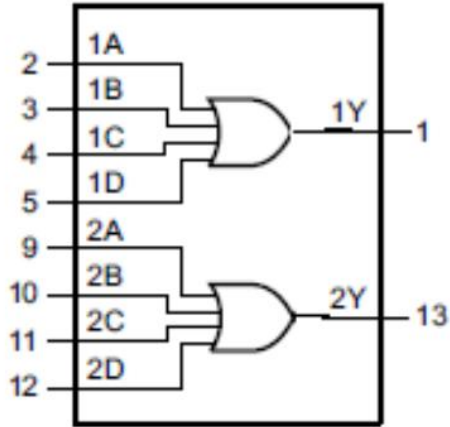

Figure 1. Functional diagram

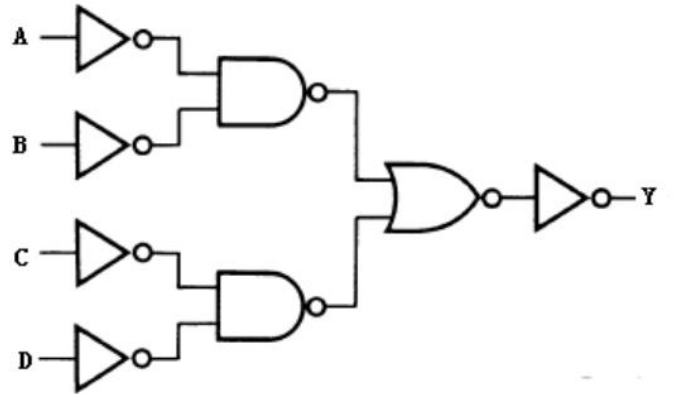
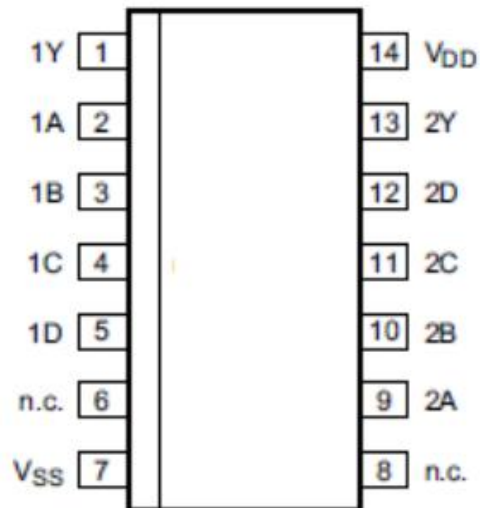

Figure 2. Logic diagram(one gate)

### Pin Configurations



Pin Description

Pin No.	Pin Name	Description
1	1Y	data output
2	1A	data input
3	1B	data input
4	1C	data input
5	1D	data input
6	n.c.	not connected
7	V <sub>SS</sub>	ground (0V)
8	n.c.	not connected
9	2A	data input
10	2B	data input
11	2C	data input
12	2D	data input
13	2Y	data output
14	V <sub>DD</sub>	supply voltage

Function Table

Input				Output
nA	nB	nC	nD	nY
L	L	L	L	L
H	X	X	X	H
X	H	X	X	H
X	X	H	X	H
X	X	X	H	H

Note: H=HIGH voltage level; L=LOW voltage level;X=don't care

Electrical Parameter

Absolute Maximum Ratings (Voltages are referenced to V<sub>SS</sub> (ground=0V), unless otherwise specified.)

Parameter	Symbol	Conditions	Min.	Max.	Unit
supply voltage	V <sub>DD</sub>	-	-0.5	+18	V
DC input current	I <sub>IK</sub>	any one input	-	±10	mA
input voltage	V <sub>I</sub>	all inputs	-0.5	V <sub>DD</sub> +0.5	V
storage temperature	T <sub>stg</sub>	-	-65	+150	°C
total power dissipation	P <sub>tot</sub>	-	-	500	mW
device dissipation	P	per output transistor	-	100	mW
Soldering temperature	T <sub>L</sub>	10s	DIP	245	°C
			SOP	250	°C

Note:

[1] For DIP14 packages: above 70°C the value of  $P_{tot}$  derates linearly with 12mW/K.

[2] For SOP14 packages: above 70°C the value of  $P_{tot}$  derates linearly with 8mW/K.

[3] For (T)SSOP14 packages: above 60°C the value of  $P_{tot}$  derates linearly with 5.5mW/K.

### Recommended Operating Conditions

Parameter	Symbol	Conditions	Min.	Typ.	Max.	Unit
supply voltage	$V_{DD}$	-	3	-	15	V
ambient temperature	$T_{amb}$	in free air	-40	-	+105	°C

## Electrical Characteristics

DC Characteristics 1 ( $T_{amb}=25^{\circ}\text{C}$ , voltages are referenced to  $V_{SS}$  (ground=0V), unless otherwise specified.)

Parameter	Symbol	Conditions(V)			$T_{amb}=25^{\circ}\text{C}$			Unit
		$V_O$	$V_{IN}$	$V_{DD}$	Min.	Typ.	Max.	
supply current	$I_{DD}$	-	0, 5	5	-	0.01	0.25	$\mu\text{A}$
		-	0, 10	10	-	0.01	0.5	$\mu\text{A}$
		-	0, 15	15	-	0.01	1	$\mu\text{A}$
LOW-level output current	$I_{OL}$	0.4	0, 5	5	0.51	1	-	mA
		0.5	0, 10	10	1.3	2.6	-	mA
		1.5	0, 15	15	3.4	6.8	-	mA
HIGH-level output current	$I_{OH}$	4.6	0, 5	5	-0.51	-1	-	mA
		2.5	0, 5	5	-1.6	-3.2	-	mA
		9.5	0, 10	10	-1.3	-2.6	-	mA
		13.5	0, 15	15	-3.4	-6.8	-	mA
LOW-level output voltage	$V_{OL}$	-	0, 5	5	-	0	0.05	V
		-	0, 10	10	-	0	0.05	V
		-	0, 15	15	-	0	0.05	V
HIGH-level output voltage	$V_{OH}$	-	0, 5	5	4.95	5	-	V
		-	0, 10	10	9.95	10	-	V
		-	0, 15	15	14.95	15	-	V
LOW-level input voltage	$V_{IL}$	0.5, 4.5	-	5	-	-	1.5	V
		1, 9	-	10	-	-	3	V
		1.5, 13.5	-	15	-	-	4	V
HIGH-level input voltage	$V_{IH}$	4.5	-	5	3.5	-	-	V
		9	-	10	7	-	-	V
		13.5	-	15	11	-	-	V

input leakage current	$I_I$	-	0, 15	15	-	$\pm 10^{-5}$	$\pm 0.1$	$\mu A$
-----------------------	-------	---	-------	----	---	---------------	-----------	---------

**DC Characteristics 2**

( $T_{amb} = -40^{\circ}C$  to  $+105^{\circ}C$ , voltages are referenced to  $V_{SS}$  (ground=0V), unless otherwise specified.)

Parameter	Symbol	Conditions(V)			$T_{amb} = -40^{\circ}C$		$T_{amb} = +85^{\circ}C$		$T_{amb} = +105^{\circ}C$		Unit
		$V_O$	$V_{IN}$	$V_{DD}$	Min.	Max.	Min.	Max.	Min.	Max.	
supply current	$I_{DD}$	-	0, 5	5	-	0.25	-	7.5	-	7.5	$\mu A$
		-	0, 10	10	-	0.5	-	15	-	15	$\mu A$
		-	0, 15	15	-	1	-	30	-	30	$\mu A$
LOW-level output current	$I_{OL}$	0.4	0, 5	5	0.61	-	0.42	-	0.36	-	mA
		0.5	0, 10	10	1.5	-	1.1	-	0.9	-	mA
		1.5	0, 15	15	4	-	2.8	-	2.4	-	mA
HIGH-level output current	$I_{OH}$	4.6	0, 5	5	-0.61	-	-0.42	-	-0.36	-	mA
		2.5	0, 5	5	-1.8	-	-1.3	-	-1.15	-	mA
		9.5	0, 10	10	-1.5	-	-1.1	-	-0.9	-	mA
		13.5	0, 15	15	-4	-	-2.8	-	-2.4	-	mA
LOW-level output voltage	$V_{OL}$	-	0, 5	5	-	0.05	-	0.05	-	0.05	V
		-	0, 10	10	-	0.05	-	0.05	-	0.05	V
		-	0, 15	15	-	0.05	-	0.05	-	0.05	V
HIGH-level output voltage	$V_{OH}$	-	0, 5	5	4.95	-	4.95	-	4.95	-	V
		-	0, 10	10	9.95	-	9.95	-	9.95	-	V
		-	0, 15	15	14.95	-	14.95	-	14.95	-	V
LOW-level input voltage	$V_{IL}$	0.5, 4.5	-	5	-	1.5	-	1.5	-	1.5	V
		1, 9	-	10	-	3	-	3	-	3	V
		1.5, 13.5	-	15	-	4	-	4	-	4	V
HIGH-level input voltage	$V_{IH}$	4.5	-	5	3.5	-	3.5	-	3.5	-	V
		9	-	10	7	-	7	-	7	-	V
		13.5	-	15	11	-	11	-	11	-	V
input leakage current	$I_I$	-	0, 15	15	-	$\pm 0.1$	-	$\pm 1.0$	-	$\pm 1.0$	$\mu A$

AC Characteristics ( $T_{amb}=25^{\circ}\text{C}$ ,  $V_{SS}=0\text{V}$ ,  $t_r, t_f=20\text{ns}$ ,  $C_L=50\text{pF}$ ,  $R_L=200\text{K}\Omega$ , unless otherwise specified.)

Parameter	Symbol	Conditions	Min.	Typ.	Max.	Unit	
propagation delay time	$t_{PHL}, t_{PLH}$	see Figure 4	$V_{DD}=5\text{V}$	-	125	250	ns
			$V_{DD}=10\text{V}$	-	60	120	ns
			$V_{DD}=15\text{V}$	-	45	90	ns
transition time	$t_{THL}, t_{TLH}$	see Figure 4	$V_{DD}=5\text{V}$	-	100	200	ns
			$V_{DD}=10\text{V}$	-	50	100	ns
			$V_{DD}=15\text{V}$	-	40	80	ns
input capacitance	$C_i$	any input	-	5	7.5	pF	

## Testing Circuit

### AC Testing Circuit

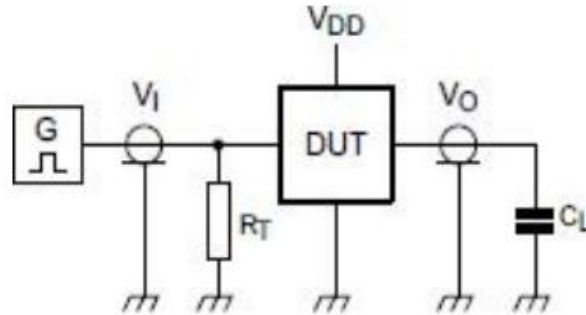

Figure 3. Test circuit for switching times

Definitions for test circuit:

DUT=Device Under Test

$C_L$ =Load capacitance including jig and probe capacitance.

$R_T$ =Termination resistance should be equal to the output impedance  $Z_o$  of the pulse generator.

### AC Testing Waveforms

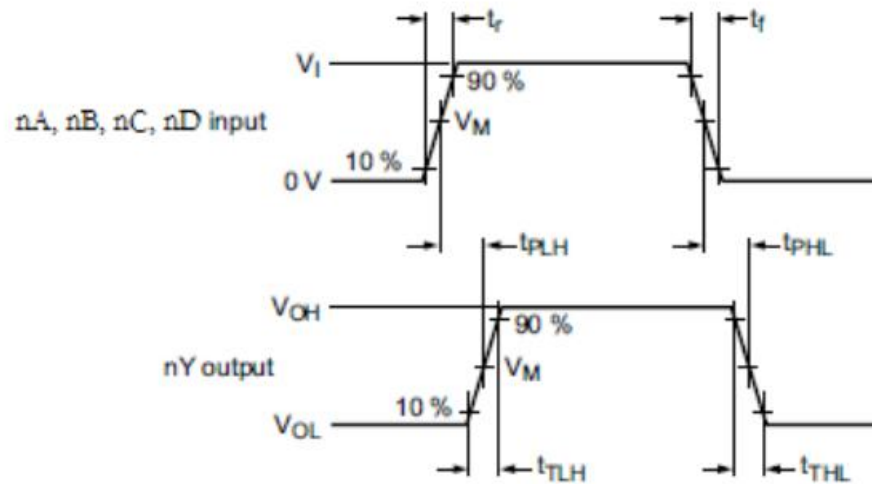

Figure 4. Propagation delay, output transition time

### Measurement Points

Supply voltage	Input	Output
$V_{DD}$	$V_M$	$V_M$
5V to 15V	$0.5 \times V_{DD}$	$0.5 \times V_{DD}$

### Test Data

Supply voltage	Input		Load
$V_{DD}$	$V_I$	$t_r, t_f$	$C_L$
5V to 15V	$V_{SS}$ or $V_{DD}$	$\leq 20\text{ns}$	50pF

## Package Information

### DIP14

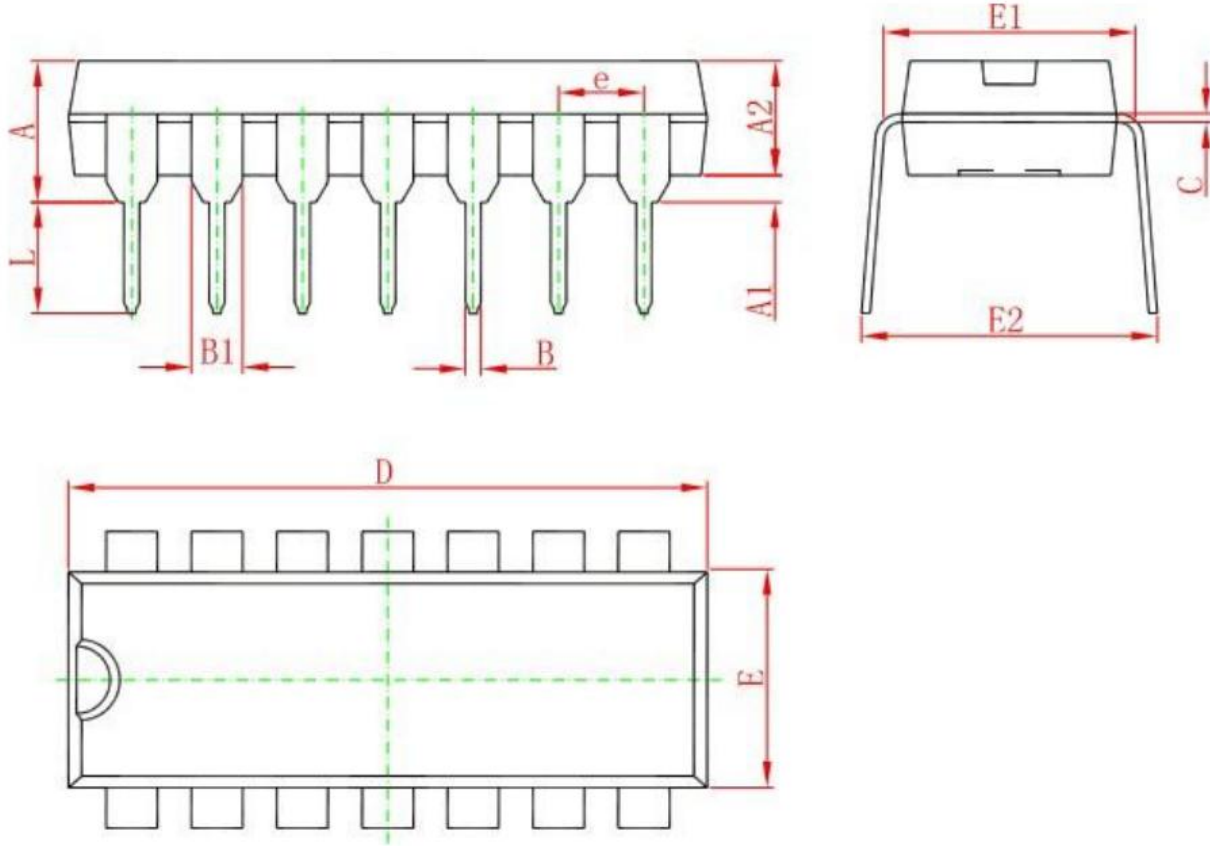

Symbol	Dimensions In Millimeters		Dimensions In Inches	
	Min	Max	Min	Max
A	3.710	4.310	0.146	0.170
A1	0.510		0.020	
A2	3.200	3.600	0.126	0.142
B	0.380	0.570	0.015	0.022
B1	1.524(BSC)		0.060(BSC)	
C	0.204	0.360	0.008	0.014
D	18.800	19.200	0.740	0.756
E	6.200	6.600	0.244	0.260
E1	7.320	7.920	0.288	0.312
e	2.540(BSC)		0.100(BSC)	
L	3.000	3.600	0.118	0.142
E2	8.400	9.000	0.331	0.354



SOP14

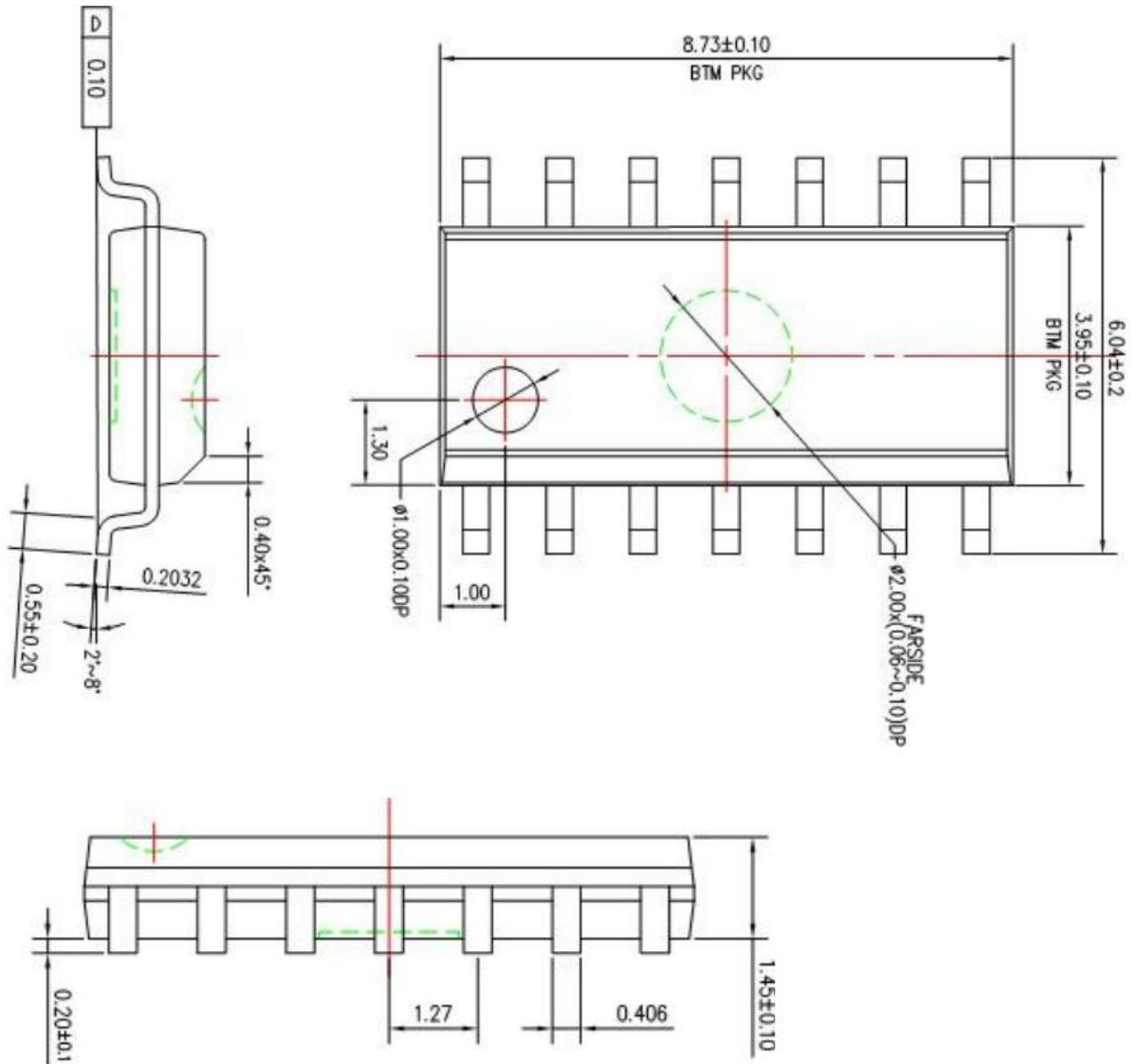

TSSOP14

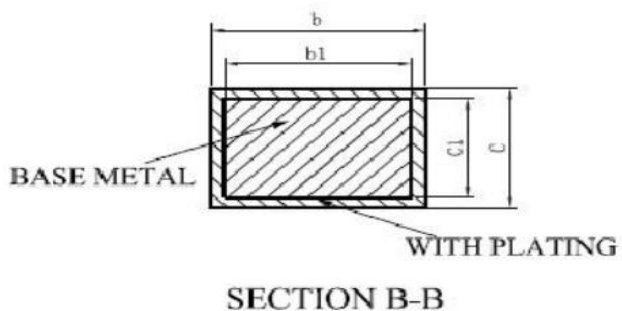
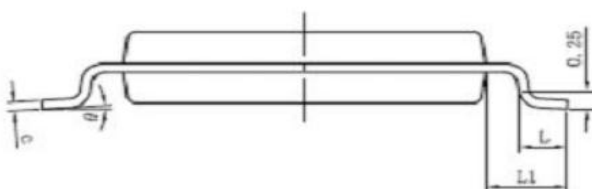
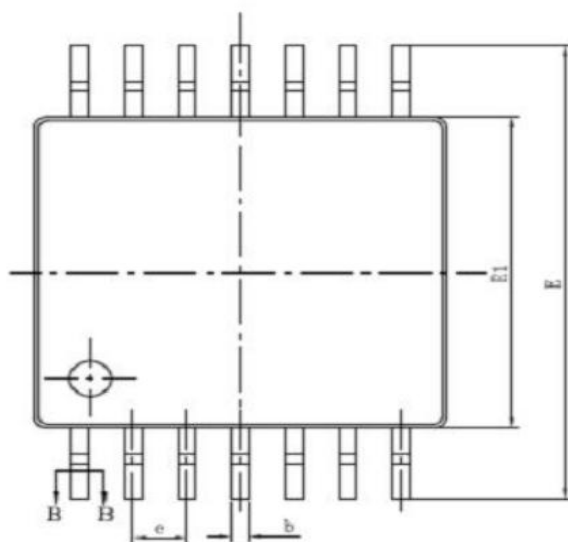
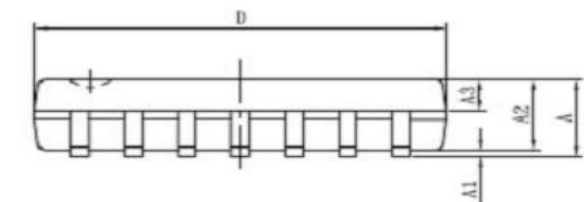

SYMBOL	MILLIMETER	
	MIN	MAX
A	-	1.20
A1	0.05	0.15
A2	0.90	1.05
A3	0.39	0.49
b	0.20	0.30
b1	0.19	0.25
c	0.13	0.19
c1	0.12	0.14
D	4.86	5.06
E1	4.30	4.50
E	6.20	6.60
e	0.65BSC	
L	0.45	0.75
L1	1.00BSC	
$\theta$	0°	8°

**Statements And Notes**

Part name	Hazardous substances or Elements									
	Lead and lead compounds	Mercury and mercury compounds	Cadmium and cadmium compounds	Hexavalent chromium compounds	Polybrominated biphenyls	Polybrominated biphenyl ethers	Dibutyl phthalate	Butyl benzyl phthalate	Di-2-ethylhexyl phthalate	Diisobutyl phthalate
Lead frame	○	○	○	○	○	○	○	○	○	○
Plastic resin	○	○	○	○	○	○	○	○	○	○
Chip	○	○	○	○	○	○	○	○	○	○
The lead	○	○	○	○	○	○	○	○	○	○
Plastic sheet installed	○	○	○	○	○	○	○	○	○	○
explanation	○: Indicates that the content of hazardous substances or elements in the detection limit of the following the SJ/T11363-2006 standard. ×: Indicates that the content of hazardous substances or elements exceeding the SJ/T11363-2006 Standard limit requirements									

Statement:

- ✧ Shenzhen xinbole electronics co., ltd. reserves the right to change the product specifications, without notice!  
Before placing an order, the customer needs to confirm whether the information obtained is the latest version, and verify the integrity of the relevant information.
- ✧ Any semiconductor product is liable to fail or malfunction under certain conditions, and the buyer shall be responsible for complying with safety standards in the system design and whole machine manufacturing using Shenzhen xinbole electronics co., ltd products, and take appropriate security measures to avoid the potential risk of failure may result in personal injury or property losses of the situation occurred!
- ✧ Product performance is never ending, Shenzhen xinbole electronics co., ltd will be dedicated to provide customers with better performance, better quality of integrated circuit products.

## X-ON Electronics

Largest Supplier of Electrical and Electronic Components

*Click to view similar products for [Logic Gates](#) category:*

*Click to view products by [XBLW](#) manufacturer:*

Other Similar products are found below :

[74HC85N](#) [NL17SG32DFT2G](#) [CD4068BE](#) [NL17SG86DFT2G](#) [NLX1G11AMUTCG](#) [NLX1G97MUTCG](#) [74LS38](#) [74LVC1G08Z-7](#)  
[CD4025BE](#) [NLV17SZ00DFT2G](#) [NLV17SZ126DFT2G](#) [NLV27WZ17DFT2G](#) [NLV74HC02ADR2G](#) [74HC32S14-13](#) [74LS133](#)  
[74LVC1G32Z-7](#) [74LVC1G86Z-7](#) [NLV74HC14ADR2G](#) [NLV74HC20ADR2G](#) [NLVVHC1G09DFT1G](#) [NLX2G86MUTCG](#)  
[74LVC2G32RA3-7](#) [74LVC2G00HD4-7](#) [NL17SG02P5T5G](#) [74LVC2G86HK3-7](#) [NLVVHC1G14DFT2G](#) [NLX1G99DMUTWG](#)  
[NLVVHC1G00DFT2G](#) [NLV7SZ57DFT2G](#) [NLV74VHC04DTR2G](#) [NLV27WZ00USG](#) [NLU1G86CMUTCG](#) [NLU1G08CMUTCG](#)  
[NL17SZ32P5T5G](#) [NL17SZ00P5T5G](#) [NL17SH02P5T5G](#) [74AUP2G00RA3-7](#) [NLVVHC1GT00DFT2G](#) [NLV74HC02ADTR2G](#)  
[NLX1G332CMUTCG](#) [NLVHCT132ADTR2G](#) [NL17SG86P5T5G](#) [NL17SZ05P5T5G](#) [NLV74VHC00DTR2G](#) [NLVVHC1G02DFT1G](#)  
[NLV74HC86ADR2G](#) [74LVC2G32HK3-7](#) [74LVC2G86RA3-7](#) [NL17SZ38DBVT1G](#) [NLV18SZ00DFT2G](#)