

General Description

The CD4094 is an 8-stage serial shift register. It has a storage latch associated with each stage for strobing data from the serial input to parallel buffered 3-state outputs QP0 to QP7. The parallel outputs may be connected directly to common bus lines. Data is shifted on positive-going clock transitions. The data in each shift register stage is transferred to the storage register when the strobe (STR) input is HIGH. Data in the storage register appears at the outputs whenever the output enable (OE) signal is HIGH.

Two serial outputs (QS1 and QS2) are available for cascading a number of CD4094 devices. Serial data is available at QS1 on positive-going clock edges to allow high-speed operation in cascaded systems with a fast clock rise time. The same serial data is available at QS2 on the next negative going clock edge. This is used for cascading CD4094 devices when the clock has a slow rise time.

It operates over a recommended V_{DD} power supply range of 3V to 15V referenced to VSS (usually ground). Unused inputs must be connected to V_{DD} , V_{SS} , or another input.

Features

- Wide supply voltage range from 3v to 15v
- Fully static operation
- 5V, 10V, and 15V parametric ratings
- Standardized symmetrical output characteristics
- Specified from -40°C to +85°C
- Packaging information: DIP16/SOP16/TSSOP16

Ordering Information

DEVICE	Package Type	MARKING	Packing	Packing QTY
CD4094BE	DIP-16	CD4094BE	Tube	1000/Box
CD4094BDTR	SOP-16	CD4094B	Tape	2500/Reel
CD4094BDTR	TSSOP-16	CD4094B	Tape	3000/Reel

Block Diagram And Pin Description

Block Diagram

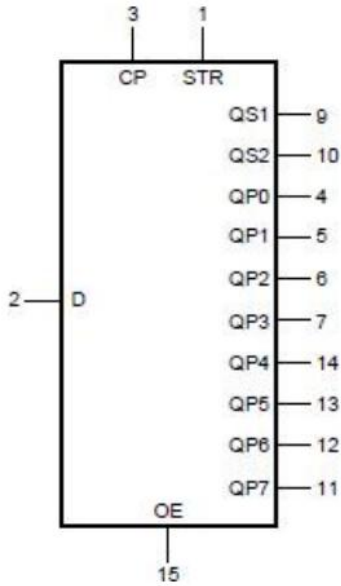

Figure 1. Logic symbol

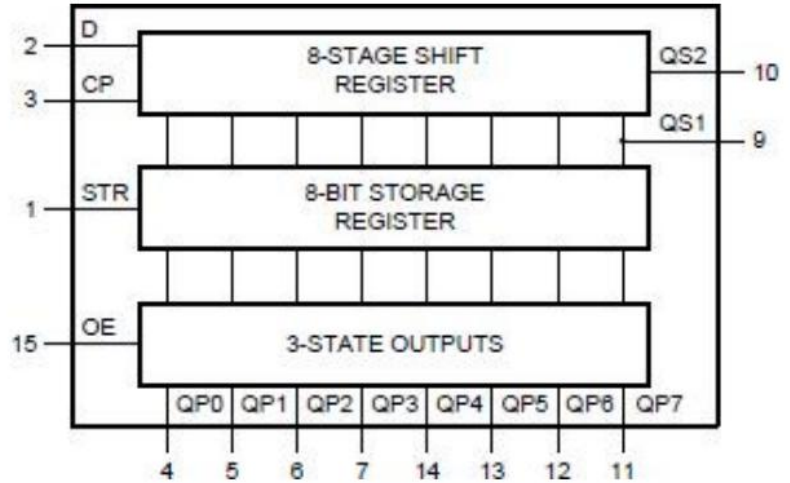

Figure 2. Functional diagram

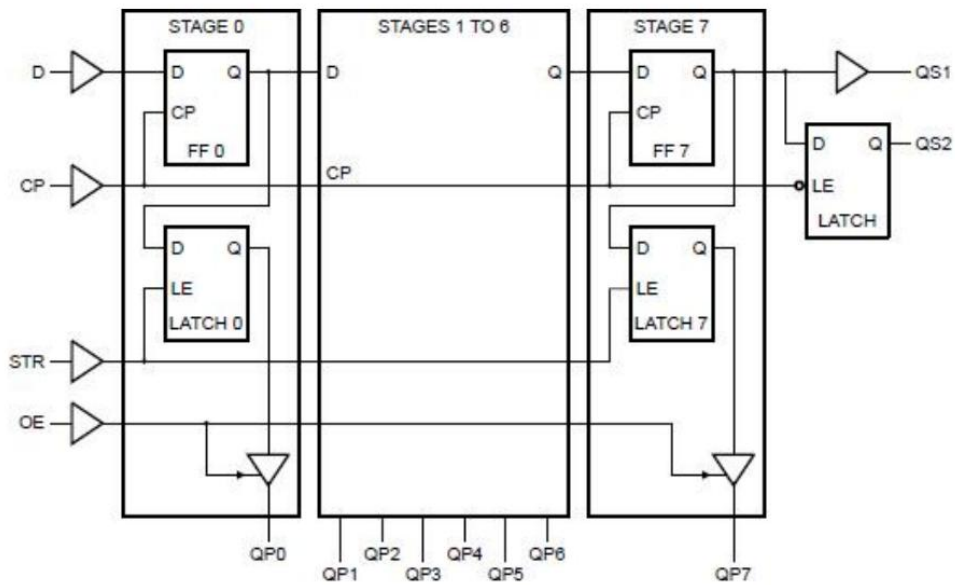

Figure 3. Logic diagram

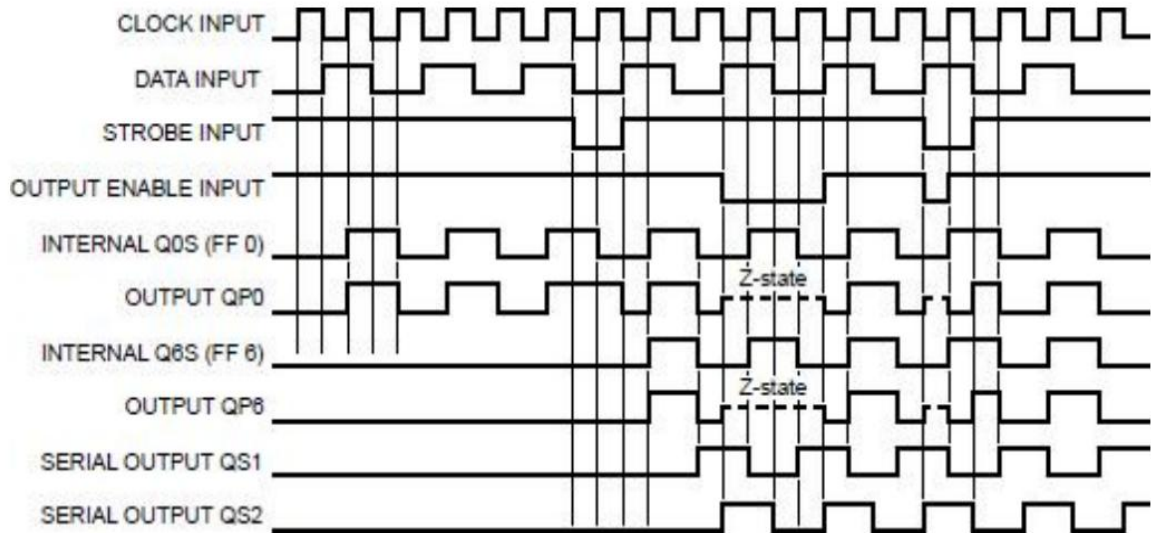
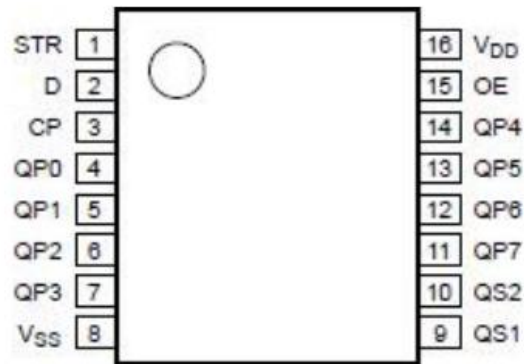

Figure 4. Timing diagram

Pin Configurations



Pin Description

Pin No.	Pin Name	Description
1	STR	strobe input
2	D	data input
3	CP	clock input
4	QP0	parallel output
5	QP1	parallel output
6	QP2	parallel output
7	QP3	parallel output
8	V _{SS}	ground supply voltage
9	QS1	serial output
10	QS2	serial output
11	QS7	parallel output
12	QS6	parallel output
13	QS5	parallel output
14	QS4	parallel output
15	OE	output enable input
16	V _{DD}	supply voltage

Function Table

Input				Parallel output		Serial output	
CP	OE	STR	D	QP0	QPn	QS1	QS2
↑	L	X	X	Z	Z	Q6S	NC
↓	L	X	X	Z	Z	NC	Q7S
↑	H	L	X	NC	NC	Q6S	NC
↑	H	H	L	L	QPn-1	Q6S	NC
↑	H	H	H	H	QPn-1	Q6S	NC
↓	H	H	H	NC	NC	NC	Q7S

Note: H=HIGH voltage level; L=LOW voltage level; X=don't care; Z=HIGH-impedance OFF-state;

NC=no change; ↑=positive-going transition; ↓=negative-going transition;

Q6S=the data in register stage 6 before the LOW to HIGH clock transition;

Q7S=the data in register stage 7 before the HIGH to LOW clock transition.

Electrical Parameter

Absolute Maximum Ratings ($T_{amb}=25^{\circ}\text{C}$, unless otherwise specified.)

Characteristic	Symbol	Conditions	Min.	Max.	Unit
supply voltage	V_{DD}	-	-0.5	+18	V
DC input current	I_{IK}	any one input	-10	-	mA
input voltage	V_I	all inputs	-0.5	+18	V
storage temperature	T_{stg}	-	-65	+150	$^{\circ}\text{C}$
total power dissipation	P_{tot}	-	-	500	mW
device dissipation	P	Per output transistor	-	100	mW
soldering temperature	T_L	10s	DIP	245	$^{\circ}\text{C}$
			SOP/TSSOP	260	$^{\circ}\text{C}$

Note:

[1] For DIP16 packages: above 70°C the value of P_{tot} derates linearly with 12mW/K.

[2] For SOP16 packages: above 70°C the value of P_{tot} derates linearly with 8mW/K.

[3] For (T)SSOP16 packages: above 60°C the value of P_{tot} derates linearly with 5.5mW/K.

Recommended Operating Conditions

Parameter	Symbol	Conditions	Min.	Typ.	Max.	Unit
supply voltage	V_{DD}	-	3	-	15	V
ambient temperature	T_{amb}	-	-40	-	+85	$^{\circ}\text{C}$
data setup time	t_{SU}	$V_{DD}=5\text{V}$	125	-	-	ns
		$V_{DD}=10\text{V}$	55	-	-	ns
		$V_{DD}=15\text{V}$	35	-	-	ns
clock pulse width	t_w	$V_{DD}=5\text{V}$	200	-	-	ns
		$V_{DD}=10\text{V}$	100	-	-	ns
		$V_{DD}=15\text{V}$	83	-	-	ns
clock input frequency	f_{max}	$V_{DD}=5\text{V}$	dc	-	1.25	MHz
		$V_{DD}=10\text{V}$		-	2.5	MHz
		$V_{DD}=15\text{V}$		-	3	MHz
clock rise and fall time	t_{rCL}, t_{fCL}	$V_{DD}=5\text{V}$	-	-	15	μs
		$V_{DD}=10\text{V}$	-	-	5	μs
		$V_{DD}=15\text{V}$	-	-	5	μs
strobe setup time	t_w	$V_{DD}=5\text{V}$	200	-	-	μs
		$V_{DD}=10\text{V}$	80	-	-	μs
		$V_{DD}=15\text{V}$	70	-	-	μs

Electrical Characteristics

DC Characteristics 1 (T_{amb}=25°C, voltages are referenced to V_{SS} (ground=0V), unless otherwise specified.)

Parameter	Symbol	Conditions(V)			T _{amb} =25°C			Unit
		V _O	V _{IN}	V _{DD}	Min.	Typ.	Max.	
supply current	I _{DD}	-	0, 5	5	-	0.04	5	μA
		-	0, 10	10	-	0.04	10	μA
		-	0, 15	15	-	0.04	20	μA
LOW-level output current	I _{OL}	0.4	0, 5	5	0.51	1	-	mA
		0.5	0, 10	10	1.3	2.6	-	mA
		1.5	0, 15	15	3.4	6.8	-	mA
HIGH-level output current	I _{OH}	4.6	0, 5	5	-0.51	-1	-	mA
		2.5	0, 5	5	-1.6	-3.2	-	mA
		9.5	0, 10	10	-1.3	-2.6	-	mA
		13.5	0, 15	15	-3.4	-6.8	-	mA
LOW-level output voltage	V _{OL}	-	0, 5	5	-	-	0.05	V
		-	0, 10	10	-	-	0.05	V
		-	0, 15	15	-	-	0.05	V
HIGH-level output voltage	V _{OH}	-	0, 5	5	4.95	5	-	V
		-	0, 10	10	9.95	10	-	V
		-	0, 15	15	14.95	15	-	V
LOW-level input voltage	V _{IL}	0.5, 4.5	-	5	-	-	1.5	V
		1, 9	-	10	-	-	3	V
		1.5, 13.5	-	15	-	-	4	V
HIGH-level input voltage	V _{IH}	0.5, 4.5	-	5	3.5	-	-	V
		1, 9	-	10	7	-	-	V
		1.5, 13.5	-	15	11	-	-	V
input leakage current	I _I	-	0, 15	15	-	±10 ⁻⁵	±0.1	μA
OFF-state output current	I _{OZ}	0, 15	0, 15	15	-	±10 ⁻⁴	±0.4	μA

DC Characteristics 2

($T_{amb} = -40^{\circ}\text{C}$ to $+85^{\circ}\text{C}$, voltages are referenced to V_{SS} (ground=0V), unless otherwise specified.)

Parameter	Symbol	Conditions(V)			$T_{amb} = -40^{\circ}\text{C}$		$T_{amb} = +85^{\circ}\text{C}$		Unit
		V_O	V_{IN}	V_{DD}	Min.	Max.	Min.	Max.	
supply current	I_{DD}	-	0, 5	5	-	5	-	150	μA
		-	0, 10	10	-	10	-	300	μA
		-	0, 15	15	-	20	-	600	μA
LOW-level output current	I_{OL}	0.4	0, 5	5	0.61	-	0.42	-	mA
		0.5	0, 10	10	1.5	-	1.1	-	mA
		1.5	0, 15	15	4	-	2.8	-	mA
HIGH-level output current	I_{OH}	4.6	0, 5	5	-0.61	-	-0.42	-	mA
		2.5	0, 5	5	-1.8	-	-1.3	-	mA
		9.5	0, 10	10	-1.5	-	-1.1	-	mA
		13.5	0, 15	15	-4	-	-2.8	-	mA
LOW-level output voltage	V_{OL}	-	0, 5	5	-	0.05	-	0.05	V
		-	0, 10	10	-	0.05	-	0.05	V
		-	0, 15	15	-	0.05	-	0.05	V
HIGH-level output voltage	V_{OH}	-	0, 5	5	4.95	-	4.95	-	V
		-	0, 10	10	9.95	-	9.95	-	V
		-	0, 15	15	14.95	-	14.95	-	V
LOW-level input voltage	V_{IL}	0.5, 4.5	-	5	-	1.5	-	1.5	V
		1, 9	-	10	-	3	-	3	V
		1.5, 13.5	-	15	-	4	-	4	V
HIGH-level input voltage	V_{IH}	0.5, 4.5	-	5	3.5	-	3.5	-	V
		1, 9	-	10	7	-	7	-	V
		1.5, 13.5	-	15	11	-	11	-	V
input leakage current	I_I	-	0, 15	15	-	± 0.1	-	± 1	μA
OFF-state output current	I_{OZ}	0, 15	0, 15	15	-	± 0.4	-	± 12	μA

AC Characteristics ($T_{amb}=25^{\circ}\text{C}$, $V_{SS}=0\text{V}$, $t_r, t_f=20\text{ns}$, $C_L=50\text{pF}$, $R_L=200\text{K}\Omega$, unless otherwise specified.)

Parameter	Symbol	Conditions	Min.	Typ.	Max.	Unit	
propagation delay time	t_{PHL}, t_{PLH}	CP to QS1; see Figure 6	$V_{DD}=5\text{V}$	-	300	600	ns
			$V_{DD}=10\text{V}$	-	125	250	ns
			$V_{DD}=15\text{V}$	-	95	190	ns
		CP to QS2; see Figure 6	$V_{DD}=5\text{V}$	-	230	460	ns
			$V_{DD}=10\text{V}$	-	110	220	ns
			$V_{DD}=15\text{V}$	-	75	150	ns
		CP to QPn; see Figure 6	$V_{DD}=5\text{V}$	-	420	840	ns
			$V_{DD}=10\text{V}$	-	195	390	ns
			$V_{DD}=15\text{V}$	-	135	270	ns
		STR to QPn; see Figure 7	$V_{DD}=5\text{V}$	-	290	580	ns
			$V_{DD}=10\text{V}$	-	145	290	ns
			$V_{DD}=15\text{V}$	-	100	200	ns
HIGH to OFF-state/OFF-state to HIGH propagation delay	t_{PHZ}, t_{PZH}	OE to QPn; see Figure 8	$V_{DD}=5\text{V}$	-	140	280	ns
			$V_{DD}=10\text{V}$	-	60	120	ns
			$V_{DD}=15\text{V}$	-	45	90	ns
LOW to OFF-state/OFF-state to LOW propagation delay	t_{PLZ}, t_{PZL}	OE to QPn; see Figure 8	$V_{DD}=5\text{V}$	-	100	200	ns
			$V_{DD}=10\text{V}$	-	50	100	ns
			$V_{DD}=15\text{V}$	-	40	80	ns
pulse width	t_w	minimum HIGH strobe pulse; see Figure 7	$V_{DD}=5\text{V}$	-	100	200	ns
			$V_{DD}=10\text{V}$	-	40	80	ns
			$V_{DD}=15\text{V}$	-	35	70	ns
		minimum LOW clock pulse; see Figure 6	$V_{DD}=5\text{V}$	-	100	200	ns
			$V_{DD}=10\text{V}$	-	50	100	ns
			$V_{DD}=15\text{V}$	-	40	83	ns
data setup time	t_{SU}	D to CP; see Figure 9	$V_{DD}=5\text{V}$	-	60	125	ns
			$V_{DD}=10\text{V}$	-	30	55	ns
			$V_{DD}=15\text{V}$	-	20	35	ns
transition time	t_t	-	$V_{DD}=5\text{V}$	-	100	200	ns
			$V_{DD}=10\text{V}$	-	50	100	ns
			$V_{DD}=15\text{V}$	-	40	80	ns
clock input rise and fall time	t_{rCL}, t_{fCL}	-	$V_{DD}=5\text{V}$	15	-	-	us
			$V_{DD}=10\text{V}$	5	-	-	us
			$V_{DD}=15\text{V}$	5	-	-	us
Maximum clock frequency	f_{max}	see Figure 6	$V_{DD}=5\text{V}$	1.25	2.5	-	MHz
			$V_{DD}=10\text{V}$	2.5	5	-	MHz
			$V_{DD}=15\text{V}$	3	6	-	MHz
input	C_I	any input		5	7.5	pF	

capacitance					
-------------	--	--	--	--	--

Note: t_t is the same as t_{TLH} and t_{THL} .

Testing Circuit

AC Testing Circuit

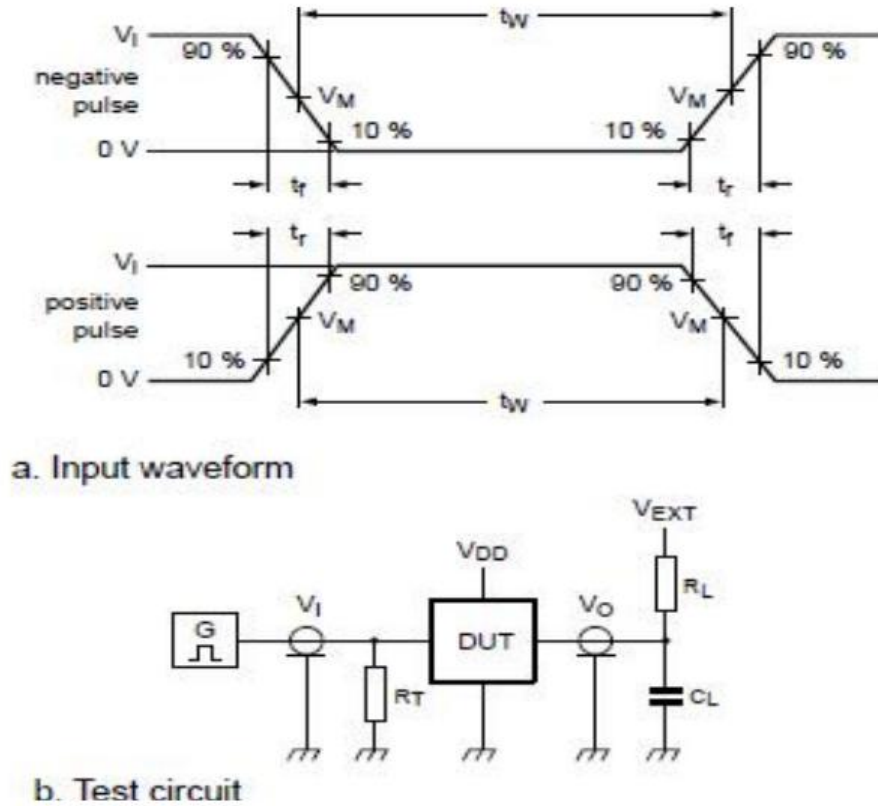

Figure 5. Test circuit for switching times

Definitions for test circuit:

DUT=Device Under Test

C_L =Load capacitance including jig and probe capacitance.

R_T =Termination resistance should be equal to the output impedance Z_o of the pulse generator.

R_L =Load resistance

V_{EXT} =External voltage for measuring switching times

AC Testing Waveforms

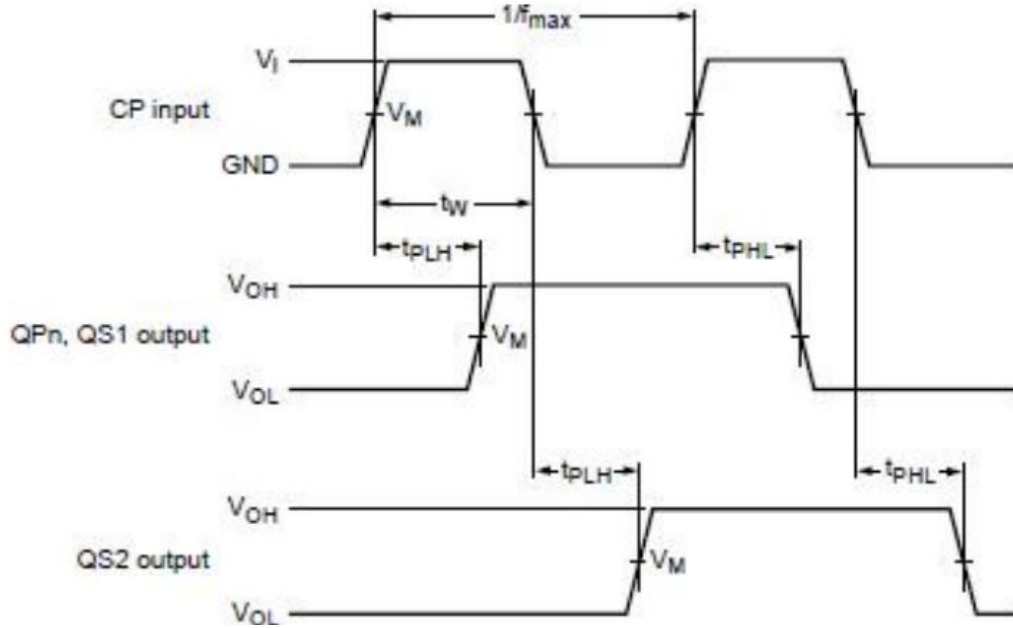

Figure 6. Clock to outputs propagation delays, and clock pulse width and maximum frequency

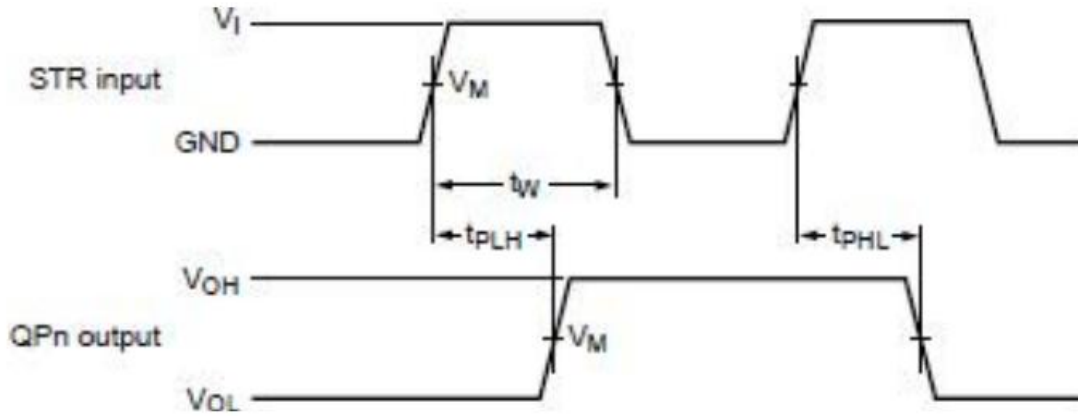

Figure 7. Strobe to output propagation delays, and strobe pulse width, set up and hold times

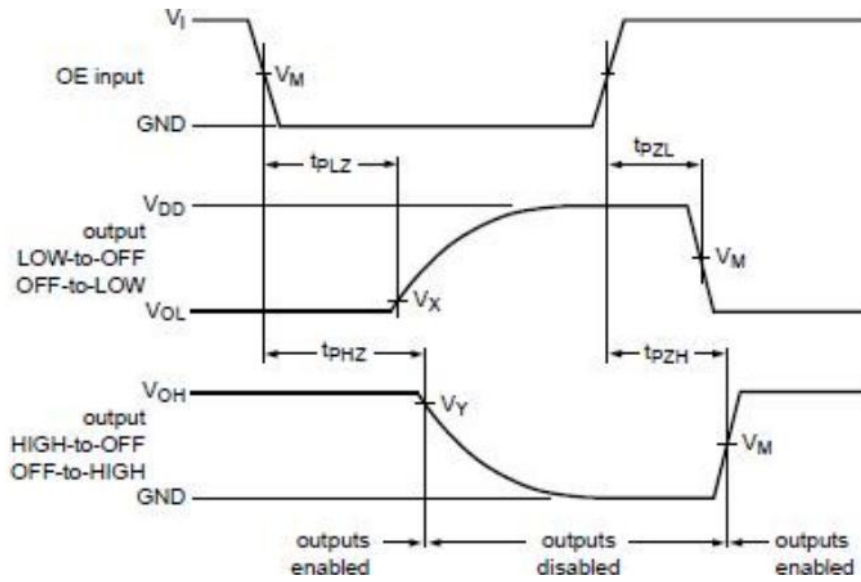

Figure 8. 3-state output enable and disable times for OE input

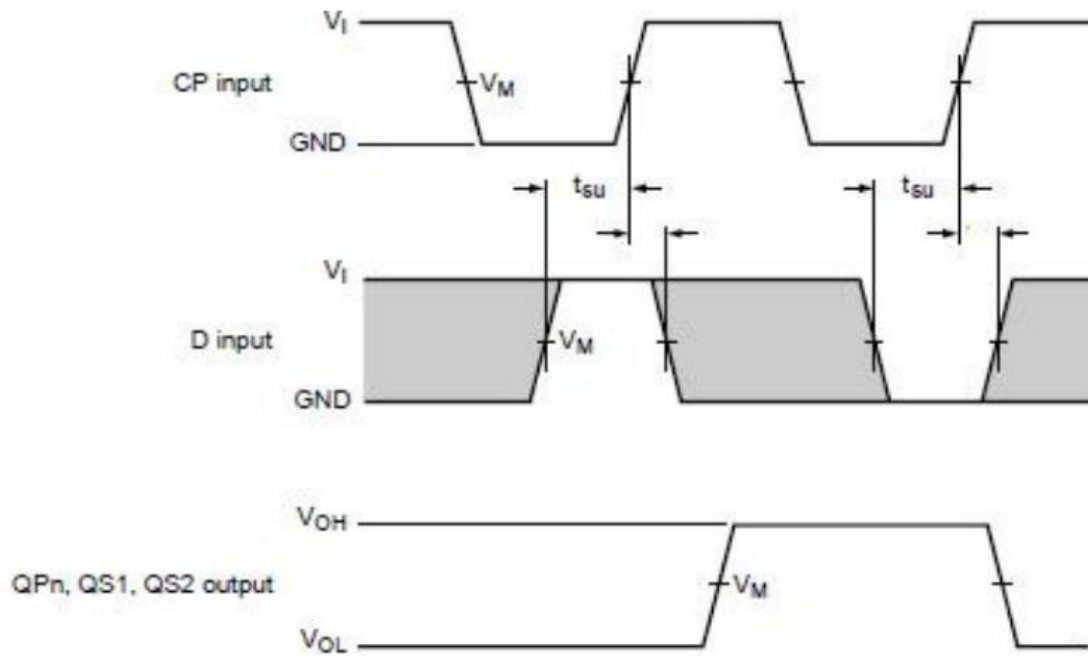

Figure 9. Data input data set up and hold times



Measurement Points

Supply voltage	Input	Output		
V_{DD}	V_M	V_M	V_X	V_Y
5V to 15V	$0.5 \times V_{DD}$	$0.5 \times V_{DD}$	$0.1 \times V_{DD}$	$0.9 \times V_{DD}$

Test Data

Supply voltage	Input		Load		Load		
V_{DD}	V_I	t_r, t_f	C_L	R_L	t_{PHL}, t_{PLH}	t_{PHZ}, t_{PZH}	t_{PLZ}, t_{PZL}
5V to 15V	V_{SS} or V_{DD}	$\leq 20\text{ns}$	50pF	1K Ω	open	V_{SS}	V_{DD}

Package Information

DIP16

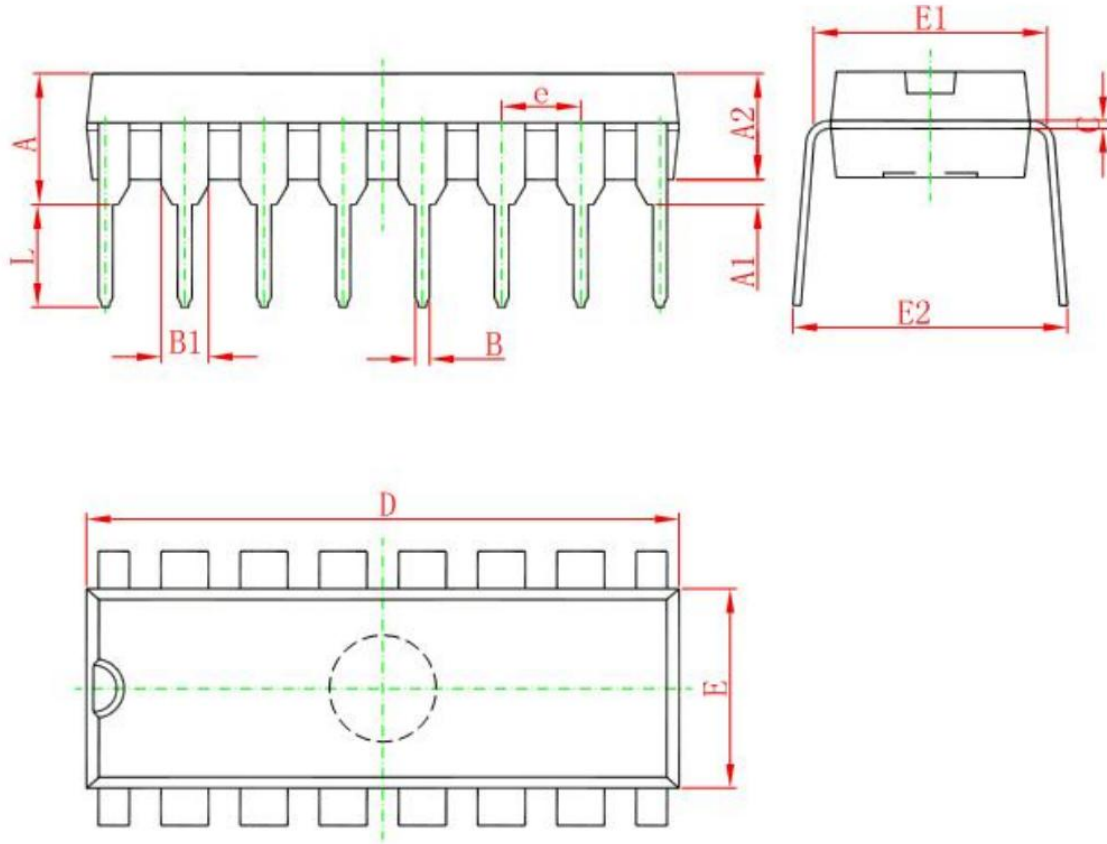

Symbol	Dimensions In Millimeters		Dimensions In Inches	
	Min	Max	Min	Max
A	3.710	4.310	0.146	0.170
A1	0.510		0.020	
A2	3.200	3.600	0.126	0.142
B	0.380	0.570	0.015	0.022
B1	1.524(BSC)		0.060(BSC)	
C	0.204	0.360	0.008	0.014
D	18.800	19.200	0.740	0.756
E	6.200	6.600	0.244	0.260
E1	7.320	7.920	0.288	0.312
e	2.540(BSC)		0.100(BSC)	
L	3.000	3.600	0.118	0.142
E2	8.400	9.000	0.331	0.354

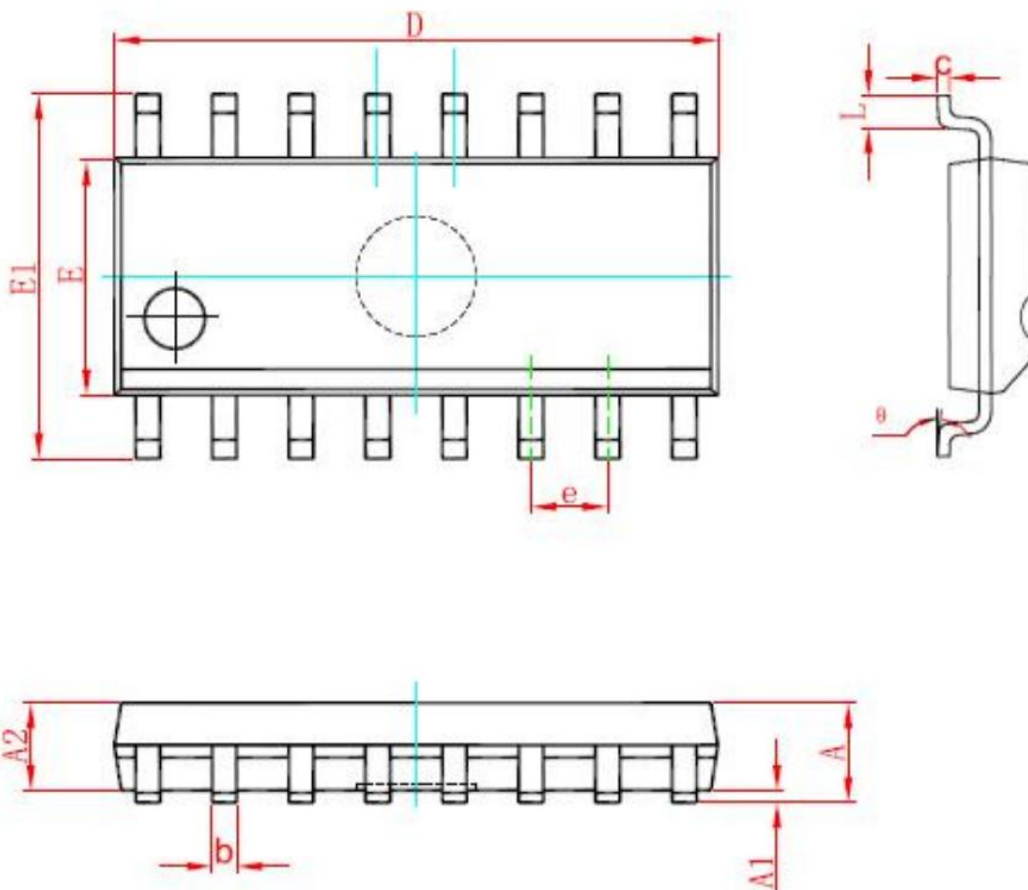

Symbol	Dimensions In Millimeters		Dimensions In Inches	
	Min	Max	Min	Max
A	1.350	1.750	0.053	0.069
A1	0.100	0.250	0.004	0.010
A2	1.350	1.550	0.053	0.061
b	0.330	0.510	0.013	0.020
c	0.170	0.250	0.007	0.010
D	9.800	10.200	0.386	0.402
E	3.800	4.000	0.150	0.157
E1	5.800	6.200	0.228	0.244
e	1.270(BSC)		0.050(BSC)	
L	0.400	1.270	0.016	0.050
θ	0°	8°	0°	8°

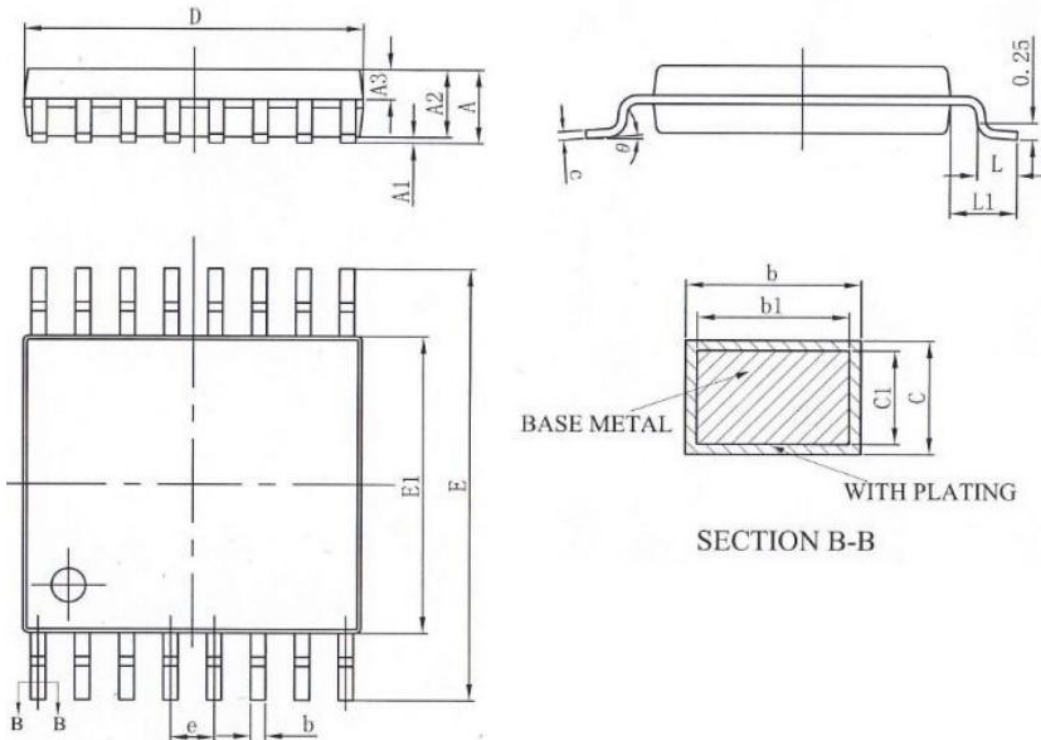

SYMBOL	MILLIMETER		
	MIN	NOM	MAX
A	-	-	1.20
A1	0.05	-	0.15
A2	0.90	1.00	1.05
A3	0.39	0.44	0.49
b	0.20	-	0.28
b1	0.19	0.22	0.25
c	0.13	-	0.17
c1	0.12	0.13	0.14
D	4.90	5.00	5.10
E	6.20	6.40	6.60
E1	4.30	4.40	4.50
e	0.65BSC		
L	0.45	0.60	0.75
L1	1.00BSC		
θ	0	-	8°

Statements And Notes

Part name	Hazardous substances or Elements									
	Lead and lead compounds	Mercury and mercury compounds	Cadmium and cadmium compounds	Hexavalent chromium compounds	Polybrominated biphenyls	Polybrominated biphenyl ethers	Dibutyl phthalate	Butyl benzyl phthalate	Di-2-ethylhexyl phthalate	Diisobutyl phthalate
Lead frame	○	○	○	○	○	○	○	○	○	○
Plastic resin	○	○	○	○	○	○	○	○	○	○
Chip	○	○	○	○	○	○	○	○	○	○
The lead	○	○	○	○	○	○	○	○	○	○
Plastic sheet installed	○	○	○	○	○	○	○	○	○	○
explanation	○: Indicates that the content of hazardous substances or elements in the detection limit of the following the SJ/T11363-2006 standard. ×: Indicates that the content of hazardous substances or elements exceeding the SJ/T11363-2006 Standard limit requirements									

Statement:

- ◇ Shenzhen xinbole electronics co., ltd. reserves the right to change the product specifications, without notice!
Before placing an order, the customer needs to confirm whether the information obtained is the latest version, and verify the integrity of the relevant information.
- ◇ Any semiconductor product is liable to fail or malfunction under certain conditions, and the buyer shall be responsible for complying with safety standards in the system design and whole machine manufacturing using Shenzhen xinbole electronics co., ltd products, and take appropriate security measures to avoid the potential risk of failure may result in personal injury or property losses of the situation occurred!
- ◇ Product performance is never ending, Shenzhen xinbole electronics co., ltd will be dedicated to provide customers with better performance, better quality of integrated circuit products.

X-ON Electronics

Largest Supplier of Electrical and Electronic Components

Click to view similar products for [Counter Shift Registers](#) category:

Click to view products by [XBLW](#) manufacturer:

Other Similar products are found below :

[CD4031BE](#) [CD4034BE](#) [NLV74HC165ADTR2G](#) [5962-9172201M2A](#) [MC100EP142MNG](#) [MC100EP016AMNG](#) [MC74LV594ADR2G](#)
[NLV14094BDTR2G](#) [NLV74HC589ADR2G](#) [AiP74HC595TA16.TR](#) [SN74LS295BN](#) [AIP74HC164TA14.TR](#) [TM74HC164](#) [74HC164D](#)
[AiP74HC165SA16.TR](#) [74HC573D](#) [AiP74HC165TA16.TR](#) [XL74HC597-TS](#) [74HC164MT/TR](#) [XL74HC595TS](#) [74HC595DMT/TR](#)
[CD4094DMT/TR](#) [74HC595D\(MS\)](#) [CD4094DM/TR](#) [74HC164D](#) [GN165D](#) [74HC595DM/TR](#) [AIP74HC595SA.TR](#) [XL4021B](#)
[74HC164D\(MS\)](#) [74HC595MT/TR](#) [XL74HC165-TS](#) [74HC595D](#) [74HC595D](#) [74HC595D.](#) [74HCT595BQ](#) [RS595SXTSS16](#)
[Aip74HC595SA16.TR](#) [SN74LS164DR-HXY](#) [74HC164DR](#) [RS595SXS16](#) [74HC165-HXY](#) [RS164XQ](#) [GN74HC595D](#) [74HC164DRG](#)
[XD74HC165](#) [SN74LV165AQWBQBRQ1](#) [AiP74HC4094SA16.TR](#) [HX74HC595IDRG](#) [CD4094DN](#)