

General Description

The L78MXX three-terminal positive regulators are available in the TO-252 package with several fixed output voltages making it useful in a wide range of applications.

Features

- Output Current up to 700mA
- Output Voltages of 5,6,8,9, 12, 15, 18,24V
- Thermal Overload Protection Short Circuit Protection
- Output Transistor Safe Operating area (SOA)Protection

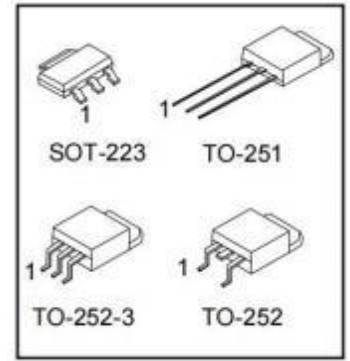

Ordering Information

DEVICE	Package Type	MARKING	Packing	Packing QTY
XBLW L78MXXHDTR	TO-252-2	78MXXH	Tape	2500/Reel

Remarks:"XXrepresents the output voltage value , such as L78M05HDTR stands for 5V

Absolute Maximum Ratings

Parameter		Symbol	Ratings	Unit
Input Voltage		V_{IN}	35	V
Output Current		I_{OUT}	700	mA
Power Dissipation ($T_c=25^\circ\text{C}$)	SOT-223	P_o	1	W
	TO-251/TO-252 TO-252-3		2	
Operating Junction Temperature		T_J	-20 ~ 125	$^\circ\text{C}$
Storage Temperature		T_{STG}	-55 ~ +150	$^\circ\text{C}$

Thermal Data

Parameter		Symbol	Ratings	Unit
Power Dissipation ($T_c=25^\circ\text{C}$)	SOT-223	θ_{JC}	15	$^\circ\text{C/W}$
	TO-251/TO-252 TO-252-3		12.5	

Block Diagram

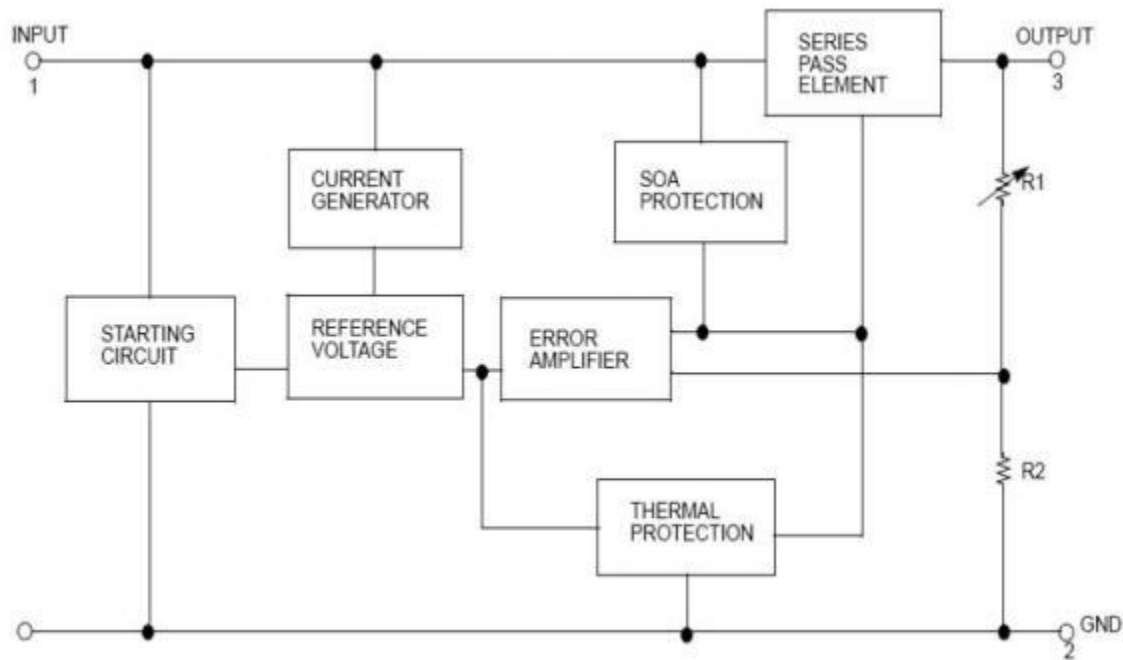

Electrical Characteristics (L78M05)

(Refer to the test circuits, $0 < T_j < +125^{\circ}\text{C}$, $I_o=350\text{mA}$, $V_i=10\text{V}$, unless otherwise specified, $C_1=0.33\mu\text{F}$, $C_o=0.1\mu\text{F}$)

Parameter	Symbol	Conditions	Value			Unit
			Min	Typ	Max	
Output Voltage	V_o	$I_o=5\text{mA}\sim 350\text{mA}$ $V_i=7\sim 20\text{V}$	4.75	5	5.25	V
Line Regulation(Note)	ΔV_o	$I_o=200\text{mA}$ $T_j=25^{\circ}\text{C}$	$V_i=7\text{V}\sim 25\text{V}$		100	mV
			$V_i=8\text{V}\sim 25\text{V}$		50	
Load Regulation(Note)	ΔV_o	$T_j=25^{\circ}\text{C}$	$I_o=5\text{mA}\sim 500\text{mA}$		100	mV
			$I_o=5\text{mA}\sim 200\text{mA}$		50	
Quiescent Current	I_Q	$T_j=25^{\circ}\text{C}$			6.0	mA
Quiescent Current Change	ΔI_Q	$I_o=5\text{mA}\sim 350\text{mA}$			0.5	mA
		$I_o=200\text{mA}, V_i=8\sim 25\text{V}$			0.8	
Output Voltage Drift	$\Delta V/\Delta T$	$I_o=5\text{mA}, T_j=0\sim 125^{\circ}\text{C}$		-0.5		mV/ $^{\circ}\text{C}$
Output Noise Voltage	V_N	$f=10\text{Hz}\sim 100\text{KHz}$		40		μV
Ripple Rejection	RR	$f=120\text{Hz}, V_i=8\sim 18\text{V}$		80		dB
Dropout Voltage	V_D	$T_j=25^{\circ}\text{C}, I_o=500\text{mA}$		2		V
Short Circuit Current	I_{SC}	$T_j=25^{\circ}\text{C}, V_i=35\text{V}$		800		mA
Peak Current	I_{PK}	$T_j=25^{\circ}\text{C}$		900		mA

Notes:

Load and line regulation are specified at constant junction temperature. Change in V_o due to heating effects must be taken into account separately. Pulse testing with low duty is used.

Electrical Characteristics (L78M06)

 (Refer to the test circuits, $0 < T_j < +125^\circ\text{C}$, $I_o=350\text{mA}$, $V_I=11\text{V}$, unless otherwise specified, $C_1=0.33\mu\text{F}$, $C_o=0.1\mu\text{F}$)

Parameter	Symbol	Conditions	Value			Unit
			Min	Typ	Max	
Output Voltage	V_o	$I_o=5\text{mA}\sim 350\text{mA}$ $V_I=8\sim 21\text{V}$	5.7	6	6.3	V
Line Regulation(Note)	ΔV_o	$I_o=200\text{mA}$ $T_j=25^\circ\text{C}$	$V_I=8\text{V}\sim 25\text{V}$		100	mV
			$V_I=9\text{V}\sim 25\text{V}$		50	
Load Regulation(Note)	ΔV_o	$T_j=25^\circ\text{C}$	$I_o=5\text{mA}\sim 500\text{mA}$		120	mV
			$I_o=5\text{mA}\sim 200\text{mA}$		60	
Quiescent Current	I_Q	$T_j=25^\circ\text{C}$			6.0	mA
Quiescent Current Change	ΔI_Q	$I_o=5\text{mA}\sim 350\text{mA}$			0.5	mA
		$I_o=200\text{mA}, V_I=9\sim 25\text{V}$			0.8	
Output Voltage Drift	$\Delta V/\Delta T$	$I_o=5\text{mA}, T_j=0\sim 125^\circ\text{C}$		-0.5		mV/ $^\circ\text{C}$
Output Noise Voltage	V_N	$f=10\text{Hz}\sim 100\text{KHz}$		45		μV
Ripple Rejection	RR	$f=120\text{Hz}, V_I=9\sim 19\text{V}$		80		dB
Dropout Voltage	V_D	$T_j=25^\circ\text{C}, I_o=500\text{mA}$		2		V
Short Circuit Current	I_{SC}	$T_j=25^\circ\text{C}, V_I=35\text{V}$		800		mA
Peak Current	I_{PK}	$T_j=25^\circ\text{C}$		900		mA

Notes:

Load and line regulation are specified at constant junction temperature. Change in V_o due to heating effects must be taken into account separately. Pulse testing with low duty is used.

Electrical Characteristics (L78M08)

 (Refer to the test circuits, $0 < T_j < +125^\circ\text{C}$, $I_o=350\text{mA}$, $V_I=14\text{V}$, unless otherwise specified, $C_1=0.33\mu\text{F}$, $C_o=0.1\mu\text{F}$)

Parameter	Symbol	Conditions	Value			Unit
			Min	Typ	Max	
Output Voltage	V_o	$I_o=5\text{mA}\sim 350\text{mA}$ $V_I=10.5\sim 23\text{V}$	7.6	8	8.4	V
Line Regulation(Note)	ΔV_o	$I_o=200\text{mA}$ $T_j=25^\circ\text{C}$	$V_I=10.5\text{V}\sim 25\text{V}$		100	mV
			$V_I=11\text{V}\sim 25\text{V}$		50	
Load Regulation(Note)	ΔV_o	$T_j=25^\circ\text{C}$	$I_o=5\text{mA}\sim 500\text{mA}$		160	mV
			$I_o=5\text{mA}\sim 200\text{mA}$		80	
Quiescent Current	I_Q	$T_j=25^\circ\text{C}$			6.0	mA
Quiescent Current Change	ΔI_Q	$I_o=5\text{mA}\sim 350\text{mA}$			0.5	mA
		$I_o=200\text{mA}, V_I=10.5\sim 25\text{V}$			0.8	
Output Voltage Drift	$\Delta V/\Delta T$	$I_o=5\text{mA}, T_j=0\sim 125^\circ\text{C}$		-0.8		mV/ $^\circ\text{C}$
Output Noise Voltage	V_N	$f=10\text{Hz}\sim 100\text{KHz}$		52		μV
Ripple Rejection	RR	$f=120\text{Hz}, V_I=11.5\sim 21.5\text{V}$		80		dB
Dropout Voltage	V_D	$T_j=25^\circ\text{C}, I_o=500\text{mA}$		2		V

Short Circuit Current	I _{SC}	T _j =25°C ,V _I =35V	800	mA
Peak Current	I _{PK}	T _j =25°C	900	mA

Notes:

Load and line regulation are specified at constant junction temperature. Change in V_o due to heating effects must be taken into account separately. Pulse testing with low duty is used.

Electrical Characteristics (L78M09)

(Refer to the test circuits, 0 < T_j < +125°C, I_o=350mA, V_I= 15V, unless otherwise specified, C₁= 0.33μF, C_o=0. 1μF)

Parameter	Symbol	Conditions	Value			Unit
			Min	Typ	Max	
Output Voltage	V _O	I _o = 5mA ~ 350mA V _I = 11.5~24V	8.45	9	9.55	V
Line Regulation(Note)	ΔV _O	I _o = 200mA T _j =25°C	V _I = 11.5V~25V		100	mV
			V _I = 12V~25V		50	
Load Regulation(Note)	ΔV _O	T _j =25°C	I _o = 5mA ~ 500mA		180	mV
			I _o = 5mA ~ 200mA		90	
Quiescent Current	I _Q	T _j =25°C			6.0	mA
Quiescent Current Change	ΔI _Q	I _o = 5mA ~ 350mA			0.5	mA
		I _o =200mA, V _I = 11.5~25V			0.8	
Output Voltage Drift	ΔV/ΔT	I _o =5mA, T _j =0~125°C		-0.8		mV/°C
Output Noise Voltage	V _N	f=10Hz~100KHz		52		μV
Ripple Rejection	RR	f=120Hz, V _I = 12.5~22.5V		80		dB
Dropout Voltage	V _D	T _j =25°C ,I _o = 500mA		2		V
Short Circuit Current	I _{SC}	T _j =25°C ,V _I =35V		800		mA
Peak Current	I _{PK}	T _j =25°C		900		mA

Notes:

Load and line regulation are specified at constant junction temperature. Change in V_o due to heating effects must be taken into account separately. Pulse testing with low duty is used.

Electrical Characteristics (L78M12)

(Refer to the test circuits, 0 < T_j < +125°C, I_o=350mA, V_I= 19V, unless otherwise specified, C₁= 0.33μF, C_o=0. 1μF)

Parameter	Symbol	Conditions	Value			Unit
			Min	Typ	Max	
Output Voltage	V _O	I _o = 5mA ~ 350mA V _I = 14.5~27V	11.4	12	12.6	V
Line Regulation(Note)	ΔV _O	I _o = 200mA T _j =25°C	V _I = 14.5V~30V		100	mV
			V _I = 16V~30V		50	
Load Regulation(Note)	ΔV _O	T _j =25°C	I _o = 5mA ~ 500mA		240	mV
			I _o = 5mA ~ 200mA		120	
Quiescent Current	I _Q	T _j =25°C			6.0	mA
Quiescent Current Change	ΔI _Q	I _o = 5mA ~ 350mA			0.5	mA

		$I_o=200\text{mA}, V_I=14.5\sim 30\text{V}$			0.8	
Output Voltage Drift	$\Delta V/\Delta T$	$I_o=5\text{mA}, T_j=0\sim 125^\circ\text{C}$			-0.8	mV/°C
Output Noise Voltage	V_N	$f=10\text{Hz}\sim 100\text{KHz}$			75	μV
Ripple Rejection	RR	$f=120\text{Hz}, V_I=15\sim 25\text{V}$			80	dB
Dropout Voltage	V_D	$T_j=25^\circ\text{C}, I_o=500\text{mA}$			2	V
Short Circuit Current	I_{SC}	$T_j=25^\circ\text{C}, V_I=35\text{V}$			800	mA
Peak Current	I_{PK}	$T_j=25^\circ\text{C}$			900	mA

Notes:

Load and line regulation are specified at constant junction temperature. Change in V_o due to heating effects must be taken into account separately. Pulse testing with low duty is used.

Electrical Characteristics (L78M15)

(Refer to the test circuits, $0 < T_j < +125^\circ\text{C}$, $I_o=350\text{mA}$, $V_I=23\text{V}$, unless otherwise specified, $C_1=0.33\mu\text{F}$, $C_o=0.1\mu\text{F}$)

Parameter	Symbol	Conditions	Value			Unit	
			Min	Typ	Max		
Output Voltage	V_o	$I_o=5\text{mA}\sim 350\text{mA}$ $V_I=17.5\sim 30\text{V}$	14.25	15	15.75	V	
Line Regulation(Note)	ΔV_o	$I_o=200\text{mA}$ $T_j=25^\circ\text{C}$	$V_I=17.5\text{V}\sim 30\text{V}$			100	mV
			$V_I=20\text{V}\sim 30\text{V}$			50	
Load Regulation(Note)	ΔV_o	$T_j=25^\circ\text{C}$	$I_o=5\text{mA}\sim 500\text{mA}$			300	mV
			$I_o=5\text{mA}\sim 200\text{mA}$			150	
Quiescent Current	I_Q	$T_j=25^\circ\text{C}$				6.0	mA
Quiescent Current Change	ΔI_Q	$I_o=5\text{mA}\sim 350\text{mA}$				0.5	mA
		$I_o=200\text{mA}, V_I=17.5\text{V}\sim 30\text{V}$				0.8	
Output Voltage Drift	$\Delta V/\Delta T$	$I_o=5\text{mA}, T_j=0\sim 125^\circ\text{C}$				-1.0	mV/°C
Output Noise Voltage	V_N	$f=10\text{Hz}\sim 100\text{KHz}$				100	μV
Ripple Rejection	RR	$f=120\text{Hz}, V_I=18.5\sim 28.5\text{V}$				70	dB
Dropout Voltage	V_D	$T_j=25^\circ\text{C}, I_o=500\text{mA}$				2	V
Short Circuit Current	I_{SC}	$T_j=25^\circ\text{C}, V_I=35\text{V}$				800	mA
Peak Current	I_{PK}	$T_j=25^\circ\text{C}$				900	mA

Notes:

Load and line regulation are specified at constant junction temperature. Change in V_o due to heating effects must be taken into account separately. Pulse testing with low duty is used.

Electrical Characteristics (L78M18)

(Refer to the test circuits, $0 < T_j < +125^\circ\text{C}$, $I_o=350\text{mA}$, $V_I=26\text{V}$, unless otherwise specified, $C_1=0.33\mu\text{F}$, $C_o=0.1\mu\text{F}$)

Parameter	Symbol	Conditions	Value			Unit	
			Min	Typ	Max		
Output Voltage	V_o	$I_o=5\text{mA}\sim 350\text{mA}$ $V_I=20.5\sim 33\text{V}$	17.1	18	18.9	V	
Line Regulation(Note)	ΔV_o	$I_o=200\text{mA}$ $V_I=21\text{V}\sim 33\text{V}$				100	mV



		T _j =25°C	V _I =24V~33V		50	
Load Regulation(Note)	ΔV _O	T _j =25°C	I _O = 5mA~500mA		360	mV
			I _O = 5mA~200mA		180	
Quiescent Current	I _Q	T _j =25°C			6.0	mA
Quiescent Current Change	ΔI _Q	I _O =5mA~350mA I _O =200mA, V _I =21V~33V			0.5	mA
					0.8	
Output Voltage Drift	ΔV/ΔT	I _O =5mA, T _j =0~125°C		-1.2		mV/°C
Output Noise Voltage	V _N	f=10Hz~100KHz		100		μV
Ripple Rejection	RR	f=120Hz, V _I =22~32V		70		dB
Dropout Voltage	V _D	T _j =25°C, I _O = 500mA		2		V
Short Circuit Current	I _{SC}	T _j =25°C, V _I =35V		800		mA
Peak Current	I _{PK}	T _j =25°C		900		mA

Notes:

Load and line regulation are specified at constant junction temperature. Change in V_O due to heating effects must be taken into account separately. Pulse testing with low duty is used.

Electrical Characteristics (L78M24)

(Refer to the test circuits, 0 < T_J < +125°C, I_O=350mA, V_I=33V, unless otherwise specified, C₁= 0.33μF, C_O=0.1μF)

Parameter	Symbol	Conditions	Value			Unit
			Min	Typ	Max	
Output Voltage	V _O	I _O = 5mA~350mA V _I =27~38V	22.8	24	25.2	V
Line Regulation(Note)	ΔV _O	I _O = 200mA T _j =25°C	V _I =27V~38V		100	mV
			V _I =28V~38V		50	
Load Regulation(Note)	ΔV _O	T _j =25°C	I _O = 5mA~500mA		480	mV
			I _O = 5mA~200mA		240	
Quiescent Current	I _Q	T _j =25°C			6.0	mA
Quiescent Current Change	ΔI _Q	I _O =5mA~350mA I _O =200mA, V _I =27V~38V			0.5	mA
					0.8	
Output Voltage Drift	ΔV/ΔT	I _O =5mA, T _j =0~125°C		-1.2		mV/°C
Output Noise Voltage	V _N	f=10Hz~100KHz		170		μV
Ripple Rejection	RR	f=120Hz, V _I =28~38V		70		dB
Dropout Voltage	V _D	T _j =25°C, I _O = 500mA		2		V
Short Circuit Current	I _{SC}	T _j =25°C, V _I =35V		800		mA
Peak Current	I _{PK}	T _j =25°C		900		mA

Notes:

Load and line regulation are specified at constant junction temperature. Change in V_O due to heating effects must be taken into account separately. Pulse testing with low duty is used.

SOT-223

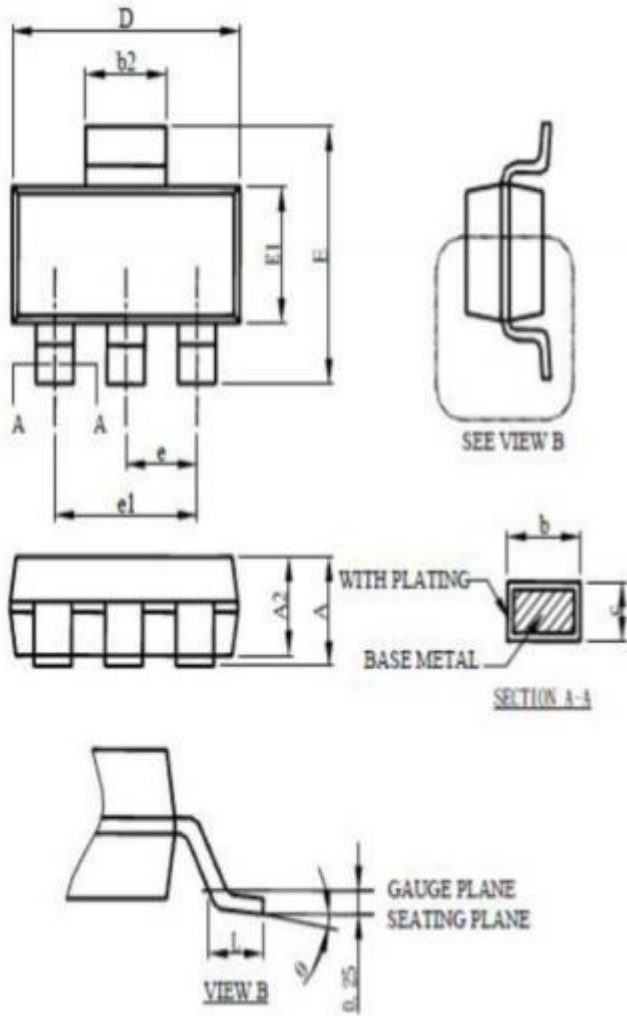

Package Information

Symbol	SOT-223			
	MILLIMETERS			
	MIN.	MAX.		
A		1.80	E1	3.30 3.70
A1	0.02	0.10	e	2.30 BSC
A2	1.55	1.65	e1	4.60 BSC
b	0.66	0.84	L	0.90
b2	2.90	3.10	θ	0° 8°
c	0.23	0.33		
D	6.30	6.70		
E	6.70	7.30		

TO252

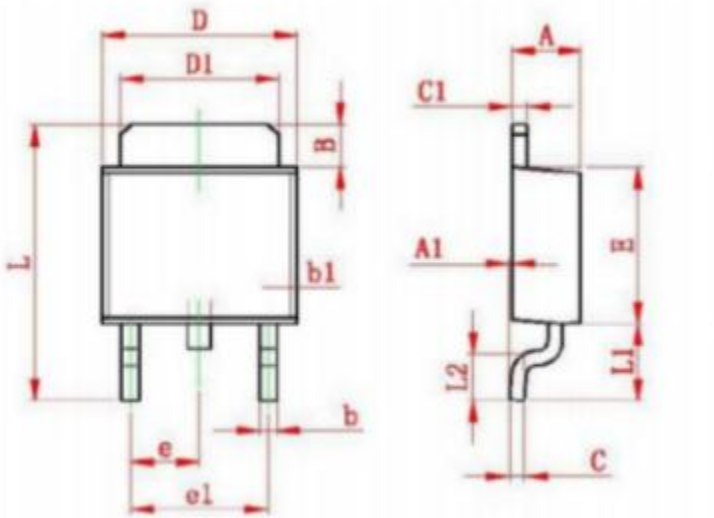

Symbol	Dimensions In Millimeters		Dimensions In Inches	
	Min	Max	Min	Max
A	2.200	2.400	0.087	0.094
A1	0.000	0.127	0.000	0.005
B	1.350	1.650	0.053	0.065
b	0.500	0.700	0.020	0.028
b1	0.700	0.900	0.028	0.035
c	0.430	0.580	0.017	0.023
c1	0.430	0.580	0.017	0.023
D	6.350	6.650	0.250	0.262
D1	5.200	5.400	0.205	0.213
E	5.400	5.700	0.213	0.224
e	2.300 TYP		0.091 TYP	
e1	4.500	4.700	0.177	0.185
L	9.500	9.900	0.374	0.390
L1	2.550	2.900	0.100	0.114
L2	1.400	1.780	0.055	0.070
V	3.80 REF		0.150 REF	

Statement:

- ◇ Shenzhen xinbole electronics co., ltd. reserves the right to change the product specifications, without notice! Before placing an order, the customer needs to confirm whether the information obtained is the latest version, and verify the integrity of the relevant information.
- ◇ Any semiconductor product is liable to fail or malfunction under certain conditions, and the buyer shall be responsible for complying with safety standards in the system design and whole machine manufacturing using Shenzhen xinbole electronics co., ltd products, and take appropriate security measures to avoid the potential risk of failure may result in personal injury or property losses of the situation occurred!
- ◇ Product performance is never ending, Shenzhen xinbole electronics co., ltd will be dedicated to provide customers with better performance, better quality of integrated circuit products.

X-ON Electronics

Largest Supplier of Electrical and Electronic Components

Click to view similar products for [LDO Voltage Regulators](#) category:

Click to view products by [XBLW](#) manufacturer:

Other Similar products are found below :

[AP7363-SP-13](#) [NCV8664CST33T3G](#) [L79M05TL-E](#) [AP7362-HA-7](#) [PT7M8202B12TA5EX](#) [TCR3DF185,LM\(CT](#) [TLF4949EJ](#)
[NCP4687DH15T1G](#) [NCV8703MX30TCG](#) [LP2951CN](#) [NCV4269CPD50R2G](#) [AP7315-25W5-7](#) [NCV47411PAAJR2G](#) [AP2111H-1.2TRG1](#)
[ZLDO1117QK50TC](#) [AZ1117ID-ADJTRG1](#) [NCV4263-2CPD50R2G](#) [NCP114BMX075TCG](#) [MC33269T-3.5G](#) [TLE4471GXT](#) [AP7315-33SA-](#)
[7](#) [NCV4266-2CST33T3G](#) [NCP715SQ15T2G](#) [NCV8623MN-50R2G](#) [NCV563SQ18T1G](#) [NCV8664CDT33RKG](#) [NCV4299CD250R2G](#)
[NCP715MX30TBG](#) [NCV8702MX25TCG](#) [L974113TR](#) [TLE7270-2E](#) [NCV562SQ25T1G](#) [AP2213D-3.3TRG1](#) [AP2202K-2.6TRE1](#)
[NCV8170BMX300TCG](#) [NCV8152MX300180TCG](#) [NCP700CMT45TBG](#) [AP7315-33W5-7](#) [LD56100DPU28R](#) [NCP154MX180300TAG](#)
[AP2210K-3.0TRE1](#) [AP2113AMTR-G1](#) [NJW4104U2-33A-TE1](#) [MP2013AGG-5-P](#) [NCV8775CDT50RKG](#) [NJM2878F3-45-TE1](#) [S-](#)
[19214B00A-V5T2U7](#) [S-19214B50A-V5T2U7](#) [S-19213B50A-V5T2U7](#) [S-19214BC0A-E8T1U7*1](#)