

General Description

The MC34063A is a monolithic control circuit containing the primary functions required for DC-to-DC converters. This device consists of an internal temperature compensated reference (1.25V), comparator, controlled duty cycle oscillator with an active current limit circuit, driver and high current output switch. The IC is specifically designed to be used in Step-Down and Step-Up and Voltage-Inverting applications with a minimum number of external components.

The MC34063A is available in DIP8 and SOP8 package.

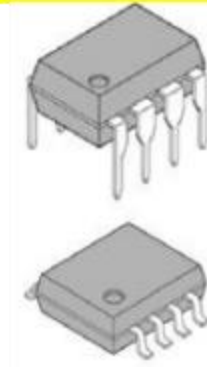

Features

- Operation from 3.0V to 40V Input
- Low Standby Current
- Current Limiting
- Output Switch Current to 1.5A
- Output Voltage Adjustable
- Frequency Operation to 100kHz
- Precision 2% Reference

Functional Block Diagram

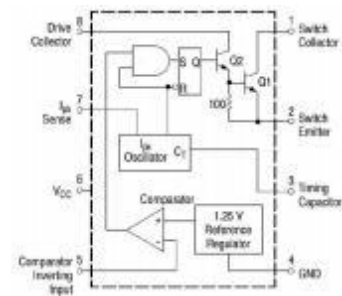

Applications

- Battery Chargers
- NICs / Switches / Hubs
- ADSL Modems
- Negative Voltage Power Supplies

Ordering Information

DEVICE	Package Type	MARKING	Packing	Packing QTY
XBLW MC34063AN	DIP-8	MC34063AN	Tube	2000/Box
XBLW MC34063ADTR	SOP-8	MC34063A	Tape	2500/Reel

Pin Configuration

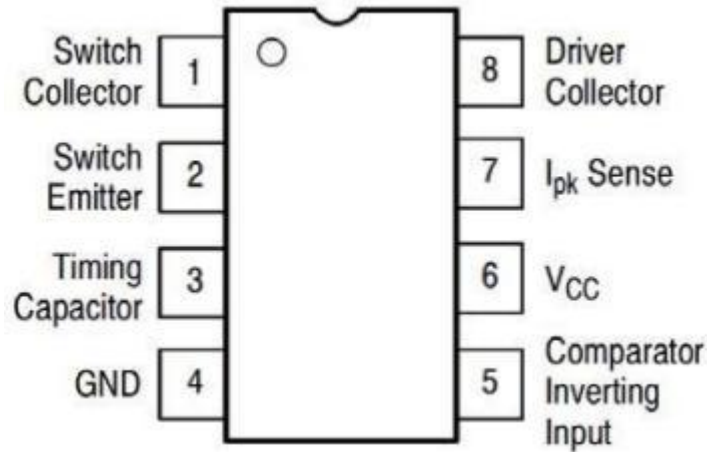

Pin Description

Pin Number	Pin Name	Function Description	Pin Number	Pin Name	Function Description
1	SC	Switch collector	5	FB	Comparator inverting input
2	SE	Switch emitter	6	V _{CC}	Input voltage
3	CT	Timing capacitor	7	I _{pk}	I _{pk} sense
4	GND	Ground	8	DC	Drive collector

Absolute Maximum Ratings (Ta= 25 °C)

Parameter Name	Symbol	Value	Unit
Power Supply Voltage	V _{CC}	40	V
Comparator Input Voltage Range	V _{IR}	-0.3~40	V
Switch Collector Voltage	V _C (switch)	40	V
Switch Emitter Voltage (VPin1=40V)	V _E (switch)	40	V
Switch Collector to Emitter Voltage	V _{CE} (switch)	40	V
Driver Collector Voltage	V _C (drive)	40	V
Driver Collector Current	I _C (drive)	100	mA
Switch Current	I _{SW}	1.5	A
Power Dissipation	DIP8	1.25	W
	SOP8	625	mW
Operating Ambient Temperature Range	T _a	0~70	°C
Storage Temperature Range	T _{stg}	-65~ 150	°C

Electrical Characteristics (Unless otherwise noted, V_{CC}=5.0V, T_a=0~70°C)

Parameter Name	Symbol	Min	Typ	Max	Unit
OSCILLATOR					
Frequency (V _{pin5} =0V, CT=1.0nF, T _a =25°C)	fosc	24	33	42	kHz
Charge Current (V _{CC} =5.0~40V, T _a =25°C)	I _{chg}	24	35	42	μA
Discharge Current (V _{CC} =5.0~40V, T _a =25°C)	I _{dischg}	140	220	260	μA
Discharge to Charge Current Ratio (Pin7 to V _{CC} , T _a =25°C)	I _{dischg} /I _{chg}	5.2	6.5	7.5	
Current limit Sense Voltage (I _{chg} =I _{dischg} , T _a =25°C)	V _{ipk(sense)}	250	300	350	mV
OUTPUT SWITCH					
Saturation Voltage, Darlington Connection (I _{SW} =1.0A, Pins 1,8 Connected)	V _{CE(sat)}		1.0	1.3	V
Saturation Voltage, Darlington Connection (I _{SW} =1.0A, R _{pin 8} =82Ω to V _{CC} , Forced β ≈ 20)	V _{CE(sat)}		0.45	0.7	V
DC Current Gain (I _{SW} =1.0A, V _{CE} =5.0V, T _a =25°C)	hFE	50	75		
Collector Off-State Current (V _{CE} =40V)	I _{c(off)}		0.01	100	μA
COMPARATOR					
Threshold Voltage (T _a =25°C)	V _{th}	1.225	1.25	1.275	V
Threshold Voltage (T _a =0~70°C)		1.21		1.29	
Threshold Voltage Line Regulation (V _{CC} =3.0~40V)	Regline		1.4	5.0	mV
Input Bias Current (V _{in} =0V)	I _B		-20	-400	nA
TOTAL DEVICE					
Supply Current (V _{CC} =5.0~40V, CT=1.0nF, Pin7=V _{CC} , V _{pin5} >V _{th} , pin2=Gnd, Remaining Pins Open)	I _{CC}			4.0	μA

Characteristics Curves

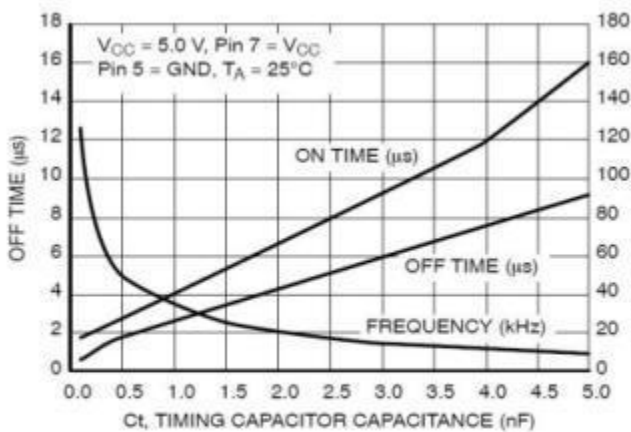

Oscillator Frequency

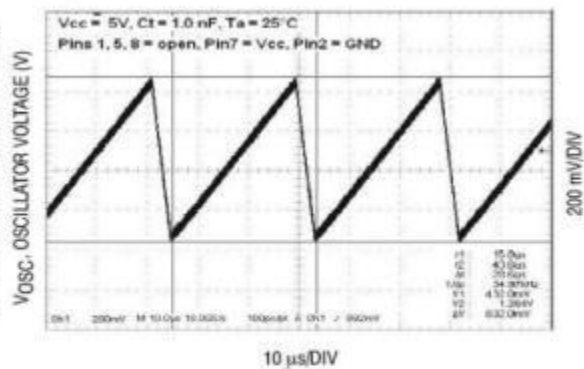

Timing Capacitor Waveform

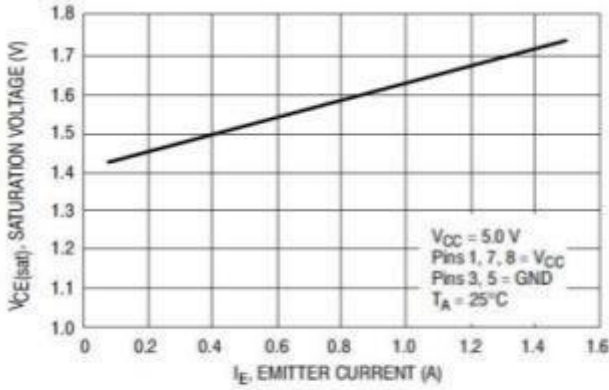

Emitter Follower Configuration Output
Saturation Voltage Versus Emitter Current

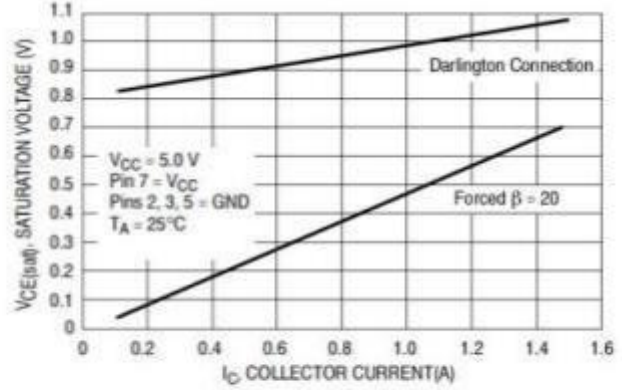

Common Emitter Configuration Output
Switch Saturation Voltage Versus Collector Current

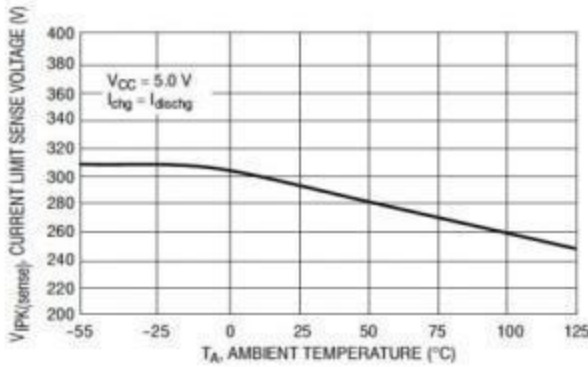

Current Limit Sense Voltage Versus Temperature

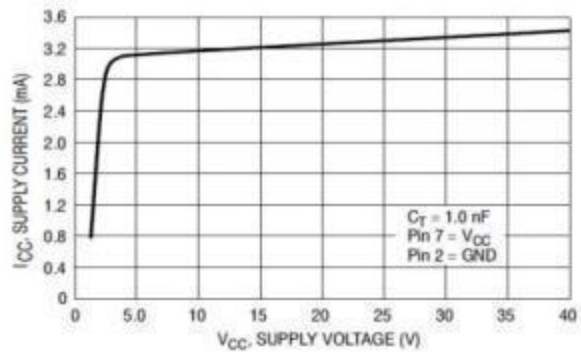

Standby Supply Current Versus Supply Voltage

Typical Application

1. Step-Up Converter

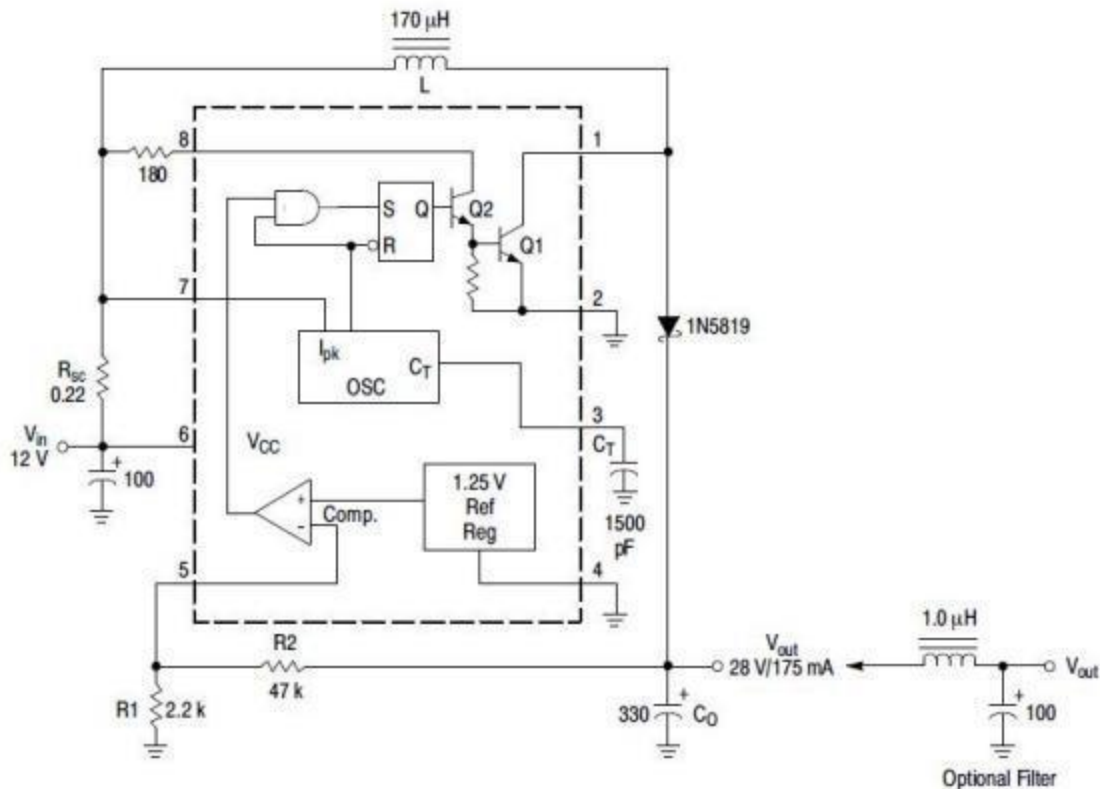

Test	Conditions	Results
Line Regulation	$V_{in}=8.0V\sim 16V, I_o=175mA$	$30mV=\pm 0.05\%$
Load Regulation	$V_{in}=12V, I_o=75mA\sim 175mA$	$10mV=\pm 0.017\%$
Output Ripple	$V_{in}=12V, I_o=175mA$	$400mV_{pp}$
Efficiency	$V_{in}=12V, I_o=175mA$	87.7%
Output Ripple With Optional Filter	$V_{in}=12V, I_o=175mA$	$40mV_{pp}$

2. Step-Down Converter

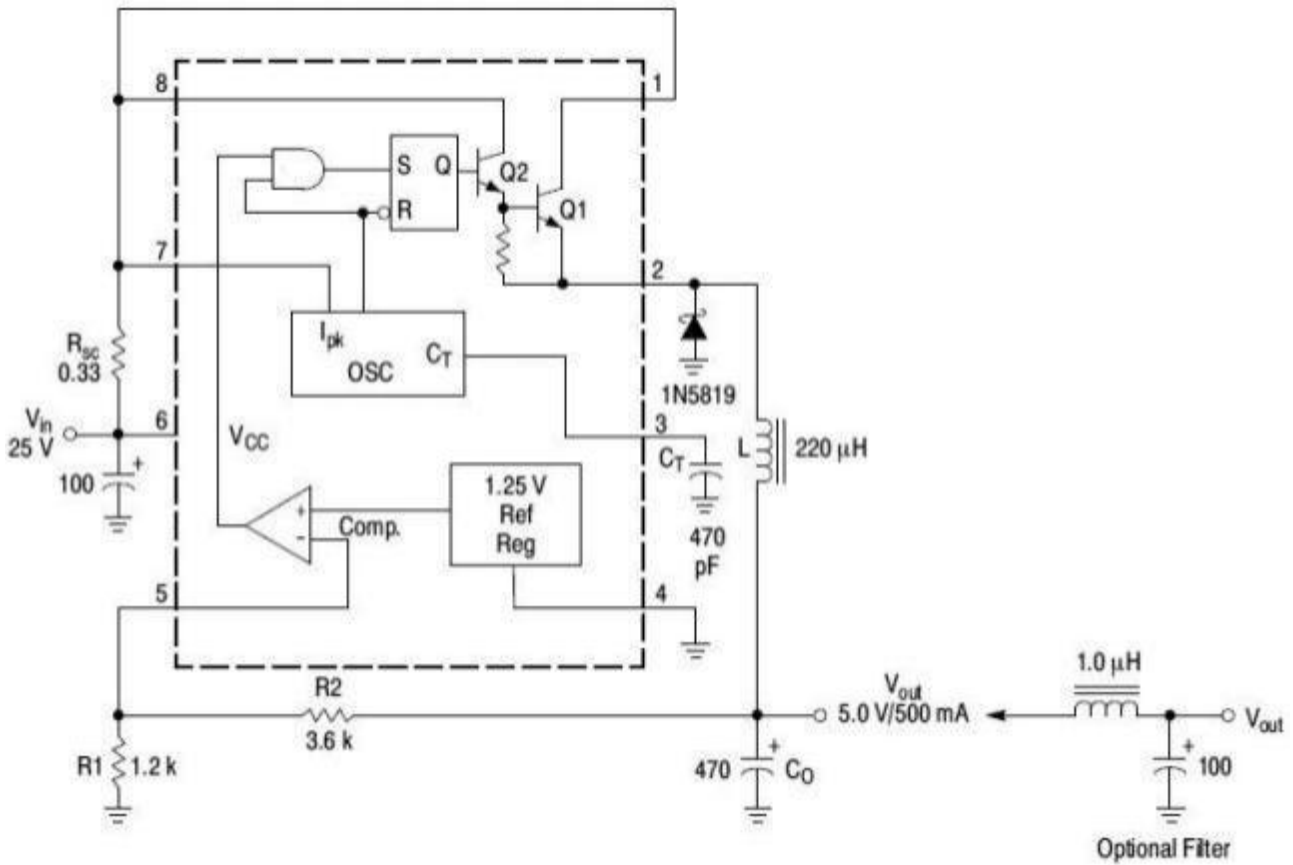

Test	Conditions	Results
Line Regulation	$V_{in}=15V\sim 25V, I_o=500mA$	$12mV=\pm 0.12\%$
Load Regulation	$V_{in}=25V, I_o=50mA\sim 500mA$	$3.0mV=\pm 0.03\%$
Output Ripple	$V_{in}=25V, I_o=500mA$	$120mV_{pp}$
Short Circuit Current	$V_{in}=25V, R_L=0.1\Omega$	$1.1A$
Efficiency	$V_{in}=25V, I_o=500mA$	83.7%
Output Ripple With Optional Filter	$V_{in}=25V, I_o=500mA$	$40mV_{pp}$

3. Voltage Inverting Converter

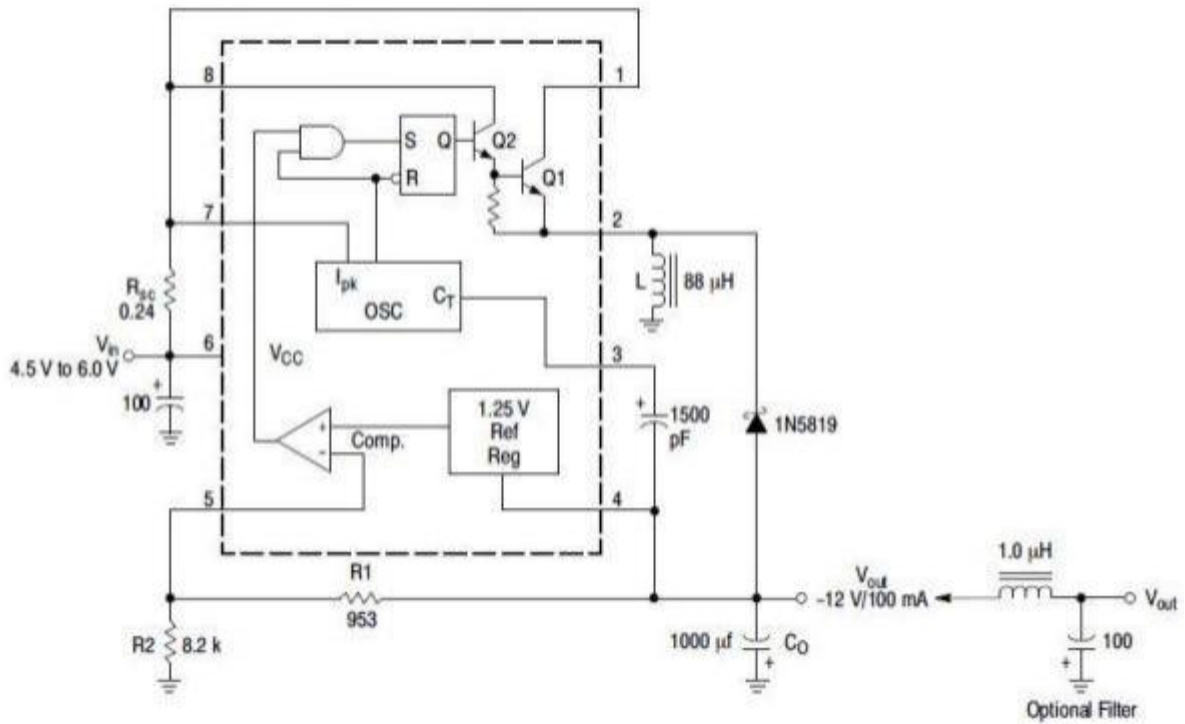

Test	Conditions	Results
Line Regulation	$V_{in}=4.5V\sim 6.0V, I_o=100mA$	$3.0mV=\pm 0.012\%$
Load Regulation	$V_{in}=5.0V, I_o=10mA\sim 100mA$	$0.022V=\pm 0.09\%$
Output Ripple	$V_{in}=5.0V, I_o=100mA$	500mVpp
Short Circuit Current	$V_{in}=5.0V, R_L=0.1\Omega$	910mA
Efficiency	$V_{in}=5.0V, I_o=100mA$	62.2%
Output Ripple With Optional Filter	$V_{in}=5.0V, I_o=100mA$	70mVpp

Application Information

Calculation	Step-Up	Step-Down	Voltage-Inverting
t_{on}/t_{off}	$\frac{V_{out} + V_F - V_{in(min)}}{V_{in(min)} - V_{sat}}$	$\frac{V_{out} + V_F}{V_{in(min)} - V_{sat} - V_{out}}$	$\frac{ V_{out} + V_F}{V_{in} - V_{sat}}$
$(t_{on} + t_{off})$	$\frac{1}{f}$	$\frac{1}{f}$	$\frac{1}{f}$
t_{off}	$\frac{t_{on} + t_{off}}{\frac{t_{on}}{t_{off}} + 1}$	$\frac{t_{on} + t_{off}}{\frac{t_{on}}{t_{off}} + 1}$	$\frac{t_{on} + t_{off}}{\frac{t_{on}}{t_{off}} + 1}$
t_{on}	$(t_{on} + t_{off}) - t_{off}$	$(t_{on} + t_{off}) - t_{off}$	$(t_{on} + t_{off}) - t_{off}$
C_T	$4.0 \times 10^{-5} t_{on}$	$4.0 \times 10^{-5} t_{on}$	$4.0 \times 10^{-5} t_{on}$
$I_{pk(switch)}$	$2I_{out(max)} \left(\frac{t_{on}}{t_{off}} + 1 \right)$	$2I_{out(max)}$	$2I_{out(max)} \left(\frac{t_{on}}{t_{off}} + 1 \right)$
R_{sc}	$0.3/I_{pk(switch)}$	$0.3/I_{pk(switch)}$	$0.3/I_{pk(switch)}$
$L_{(min)}$	$\left(\frac{V_{in(min)} - V_{sat}}{I_{pk(switch)}} \right) t_{on(max)}$	$\left(\frac{V_{in(min)} - V_{sat} - V_{out}}{I_{pk(switch)}} \right) t_{on(max)}$	$\left(\frac{V_{in(min)} - V_{sat}}{I_{pk(switch)}} \right) t_{on(max)}$
C_O	$g \frac{I_{out} t_{on}}{V_{ripple(pp)}}$	$\frac{I_{pk(switch)} (t_{on} + t_{off})}{8V_{ripple(pp)}}$	$g \frac{I_{out} t_{on}}{V_{ripple(pp)}}$

Vsat = Saturation voltage of the output switch

VF = Forward voltage drop of the output rectifier

The following power supply characteristics must be chosen:

Vin — Nominal input voltage

Vout — Desired output voltage , | Vout | = 1.25 × (1 + R2)

R1

Iout — Desired output current
fmin — Minimum desired output switching frequency at the selected values of Vin and Io

Vripple(pp) — Desired peak-to-peak output ripple voltage. In practice, the calculated capacitor value will need to be increased due to its equivalent series resistance and board layout. The ripple voltage should be kept to a low value since it will directly affect the line and load regulation

Outline Dimensions

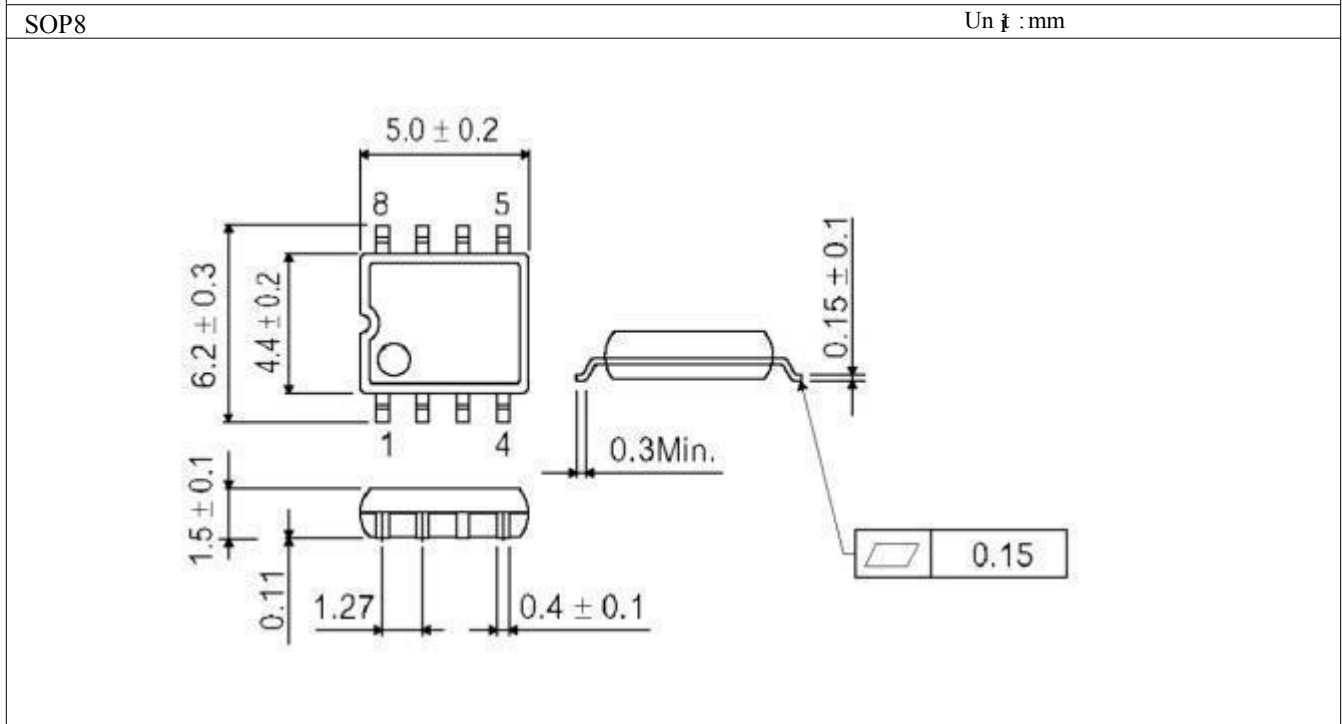
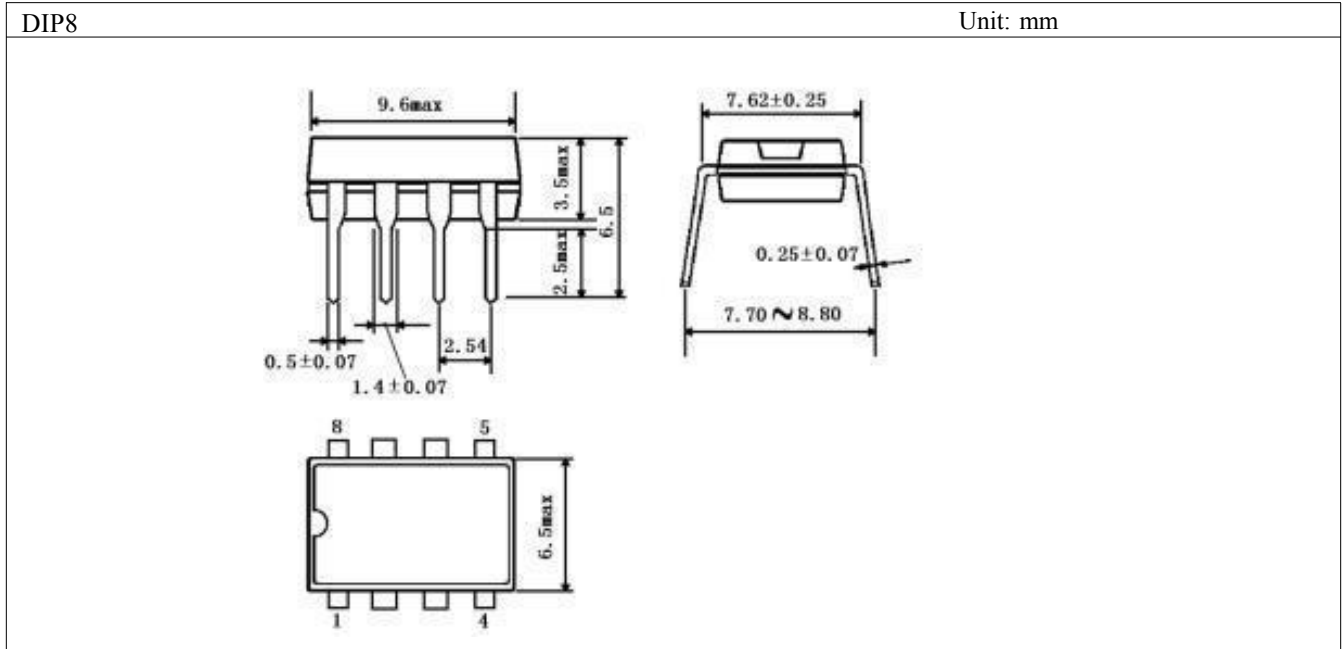

Statement:

- ◇ Shenzhen xinbole electronics co., ltd. reserves the right to change the product specifications, without notice! Before placing an order, the customer needs to confirm whether the information obtained is the latest version, and verify the integrity of the relevant information.
- ◇ Any semiconductor product is liable to fail or malfunction under certain conditions, and the buyer shall be responsible for complying with safety standards in the system design and whole machine manufacturing using Shenzhen xinbole electronics co., ltd products, and take appropriate security measures to avoid the potential risk of failure may result in personal injury or property losses of the situation occurred!
- ◇ Product performance is never ending, Shenzhen xinbole electronics co., ltd will be dedicated to provide customers with better performance, better quality of integrated circuit products.

X-ON Electronics

Largest Supplier of Electrical and Electronic Components

Click to view similar products for [Isolated DC/DC Converters](#) category:

Click to view products by [XBLW](#) manufacturer:

Other Similar products are found below :

[PSL486-7LR](#) [Q48T30020-NBB0](#) [JAHW100Y1](#) [SPB05C-12](#) [SQ24S15033-PS0S](#) [CE-1003](#) [CE-1004](#) [MAU228](#) [J80-0041NL](#) [DFC15U48D15](#)
[XGS-1205](#) [06322](#) [SPB05B-15](#) [L-DA20](#) [DCG40-5G](#) [XKS-2405](#) [DPA423R](#) [vi-m13-cw-03](#) [VI-L53-CV](#) [24IBX15-50-0ZG](#) [HZZ01204-G](#)
[SPU02L-09](#) [SPU02M-09](#) [SPU02N-09](#) [QUINT4-BUFFER/24DC/40](#) [QUINT4-CAP/24DC/5/4KJ](#) [73-551-5039I](#) [DFC15U48D15G](#) [SEN-6471-](#)
[1EM](#) [AHV2815DF/HBB](#) [MI-LC21-IX](#) [PAH-48/8.5-D48NB1-C](#) [BM3020-7A](#) [QRS2050P025K00](#) [CM2320-9EG](#) [SKMW15F-05](#)
[V300A28H400BF3](#) [TEN 15-1223](#) [TEQ 100-2418WIR](#) [TEQ 160-7218WIR](#) [R05C05TE05S-R](#) [HQA2W085W033V-N07-S](#) [AM1SS-2405SJZ](#)
[AM2DS-1224SJZ](#) [AM2DS-2405DJZ](#) [AM10SBO-4824SNZ-B](#) [AM15E-2405S-NZ](#) [AM2DS-1212SJZ](#) [AM30SBO-4805SNZ-B](#)
[LT8301ES5#WTRPBF](#)