

Product Specification

XBLW SG3524

Pulse width modulation circuit of switching power supply

WEB | www.xinboleic.com



Summarize

The SG3524 is a pulse width modulation circuit for switching power supplies. It contains a reference voltage source, error amplifier, oscillator, pulse width modulation and pulse width control Flip-flop, dual alternating output, current limiting circuit and turn-off circuit. The circuit can be used for switching power supply control of any polarity, transformer-coupled DC-DC switching power supply, transformer pressurization and polarity conversion, and other power supply applications. SG3524 operating temperature is 0°C to +70°C.

DIP-16

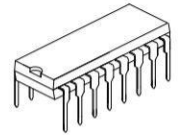

SOP-16

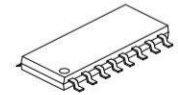

Characteristic

- With 5V reference voltage source. 100Hz to 300KHz oscillation frequency range. Good external synchronization function.
- contains two 50mA outputs.
- contains a current limiting circuit.
- Complete PWM control circuit.
- Single-ended or push-pull output.
- The total power consumption is less than 10mA.

Ordering information

Product Model	Package Type	Marking	Packing	Packing Qty
XBLW SG3524N	DIP-16	SG3524N	Tube	1000Pcs/Box
XBLW SG3524DTR	SOP-16	SG3524	Tape	2500Pcs/Reel

Functional block diagram

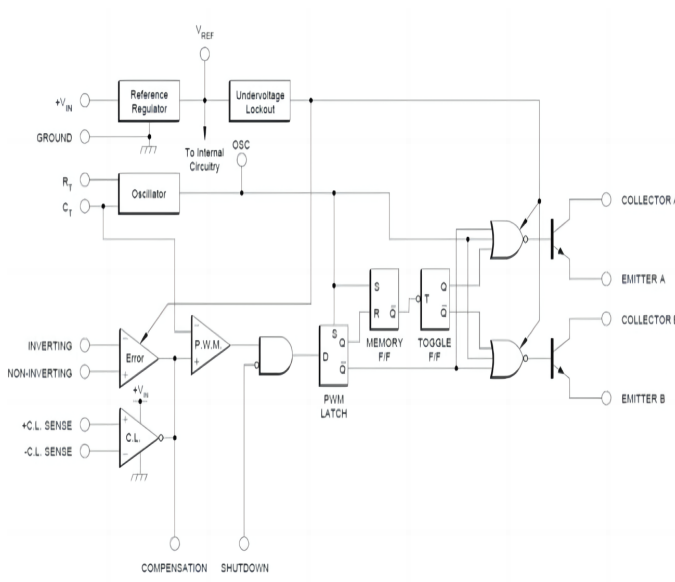

Pin diagram

INV. INPUT	1	16	V _{REF}
N.I. INPUT	2	15	+V _{IN}
OSC. OUTPUT	3	14	E _B
+C.L. SENSE	4	13	C _B
-C.L. SENSE	5	12	C _A
R _T	6	11	E _A
C _T	7	10	SHUTDOWN
GROUND	8	9	COMPENSATION

limit value

(Absolute maximum rating, if no other provisions, $T_{amb}=25^{\circ}C$)

Name (Symbol)	Price	Unit
input voltage(V_{in})	42	V
collector voltage	40	V
logic input voltage	-0.3~5.5	V
Current-limiting pin differential input(V_{sense})	-0.3~0.3	V
Each output current	100	mA
Voltage reference load	40	mA
Oscillating end charging current	5	mA
Working junction temperature	150	$^{\circ}C$
operating ambient temperature	0~70	$^{\circ}C$

Recommended working conditions

Name (Symbol)	Price	Unit
input voltage(V_{in})	8~40	V
collector voltage	0~40	V
Error amplifier common-mode input voltage	1.8~3.4-	V
Current-limiting pin differential input(V_{sense})	0.3~0.3	V
Each output current	0~50	mA
Voltage reference load	0~20	mA
Oscillating end charging current	0.03~2	mA
oscillation frequency	0.1~300	KHz
oscillation resistance(R_t)	1.8~100	K Ω
Oscillation capacitance(C_t)	1~1000	nF
Working junction temperature	150	$^{\circ}C$
operating ambient temperature	0~70	$^{\circ}C$

Electric parameter

(Without special instructions, $V_{in}=20V$, $T_A=25^{\circ}C$)

Symbol	Parameter	Condition	SG3524			Unit
			MIN.	TYP.	MAX.	
Reference voltage part Vref (without explanation, $I_L = 0mA$)						
Vref	output voltage		4.8	5.0	5.2	V
Line Reg	Voltage linearity	$V_{in}=8V\sim 40V$			30	mV
Load Reg	Load linearity	$I_L = 0$ to 20mA			50	mV
Short current	Reference short-circuit current	$V_{REF} = 0V$	25		150	mA
Oscillator (without explanation $F_{OSC} = 40KHz$, $R_T = 2.9KW$, $C_T = 0.01\mu F$)						
Fosc	oscillation frequency		36		44	KHz
	Frequency voltage drift	$V_{IN} = 8V$ to 40V			1	%
MaxFosc	maximum frequency of oscillation	$R_T = 2K$, $C_T = 1nF$	200	400		KHz
	Peak of oscillation		3		3.9	V
	Valley value of oscillation waveform		0.6		1.2	V
Pulse Width	Oscillation pulse width		0.3		1.5	us
Error amplifier Part EA (without explanation, $V_{cm}=2.5V$)						
Vio	input offset voltage				10	mV
Ib	input bias current				10	uA
Iio	input offset current				2	uA
Av	Dc open loop gain		60			dB
Vol	output low level	$V_{PIN 1} - V_{PIN 2} > 150mV$		0.2	0.5	V
Voh	Output high level	$V_{PIN 2} - V_{PIN 1} > 150mV$	3.8	4.2		V
CMR	Input common mode suppression	$V_{CM} = 1.8V$ to 3.4V	70			dB
PWM comparator section						
Min Duty	Minimum duty cycle	$V_{COMP} = 0.5V$			0	%
Max Duty	Maximum duty cycle	$V_{COMP} = 3.6V$	45	49		%
Current limiting circuit part Current Limit Amplifier ($V_{CM} = 0V$)						
Vsense	Input threshold voltage		180		220	mV
Ib	input bias current				200	uA
Circuit off part Shutdown						
Vth	The threshold voltage is turned off		0.5	0.8	1.2	V
Output part (per output)						
Cleak	Collector leakage current	$V_{CE} = 40V$			50	uA
Vcsat	Collector pressure drop	$I_C = 50mA$			2	V

Character	Test ondition	Symbol	Parameter value			Unit
			MIN.	TYP.	MAX.	
Initiation control						
Low current input	V (pin3) =0.4V	ISTL		-25	-200	μA
High current input	V (pin13) =2.4V	ISTH		25	200	μA
	V (pin13) =Vref			75		
Integral part						
Standby current (pin 6 is reference voltage, other input and output are open)	Vcc=15V	Icc		6	10	mA
	Vcc=40V			9	15	
Average power current (see 2 for test circuit diagram)	Vcc=15V; RT=12kΩ; CT=0.01μF; V (pin14) =2.0V			7.5		mA
Symbol	Parameter	Ondition	Parameter value			Unit
			MIN.	TYP.	MAX.	
Ve	Emitter output voltage	IE = 50mA	17			V
Rise time	Collector output rise time	RC = 2K			0.4	us
Fall time	Collector output drop time	RC = 2K			0.2	us
Circuit whole						
Icc	Static working current	VIN = 40V			10	mA

Applications and notes

1. Table 1(Relation between oscillation frequency and Rt and Ct)

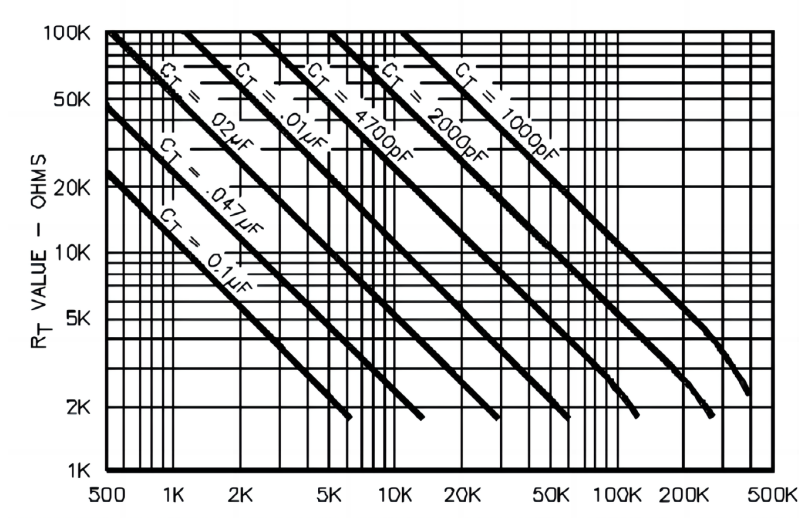

2. Table 2 (Relationship between dead zone time and Ct)

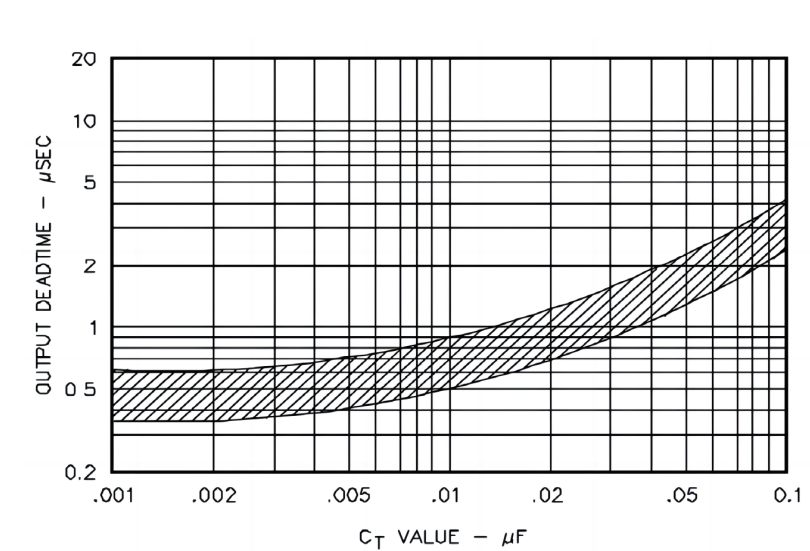

3. Internal current limiting circuit diagram

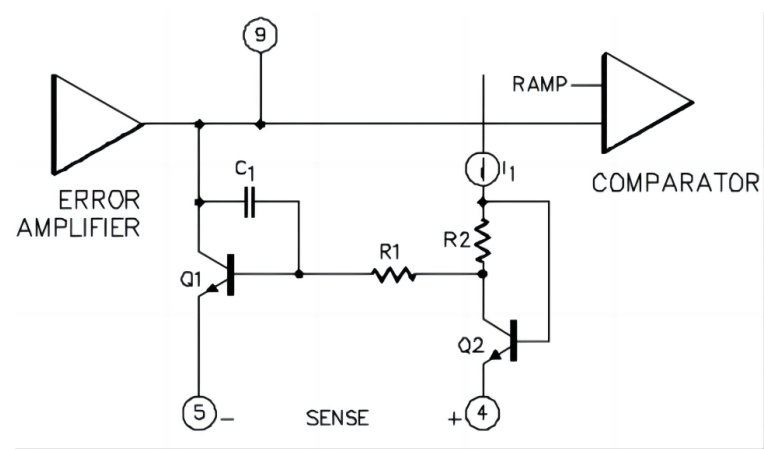

$$\text{C.L. Threshold} = V_{BE}(Q1) + I_1 \cdot R_2 - V_{BE}(Q2) = I_1 \cdot R_2 \sim 200 \text{ mV}$$

4. Single-end output application (terminal output control can reach 0~90% duty cycle)

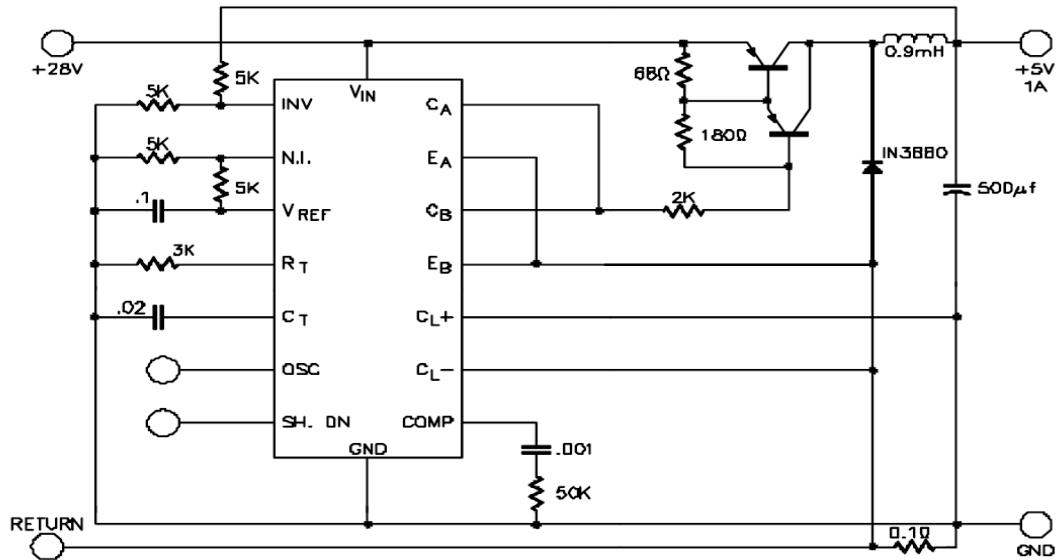

5. Push-pull output application

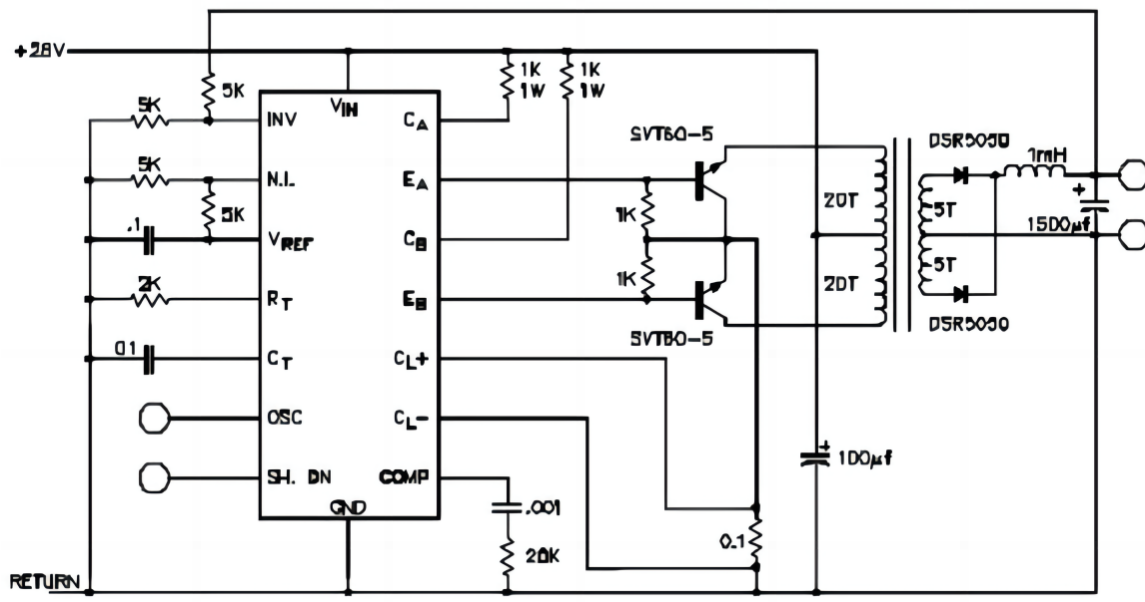

Package dimensions and outline drawings

DIP16

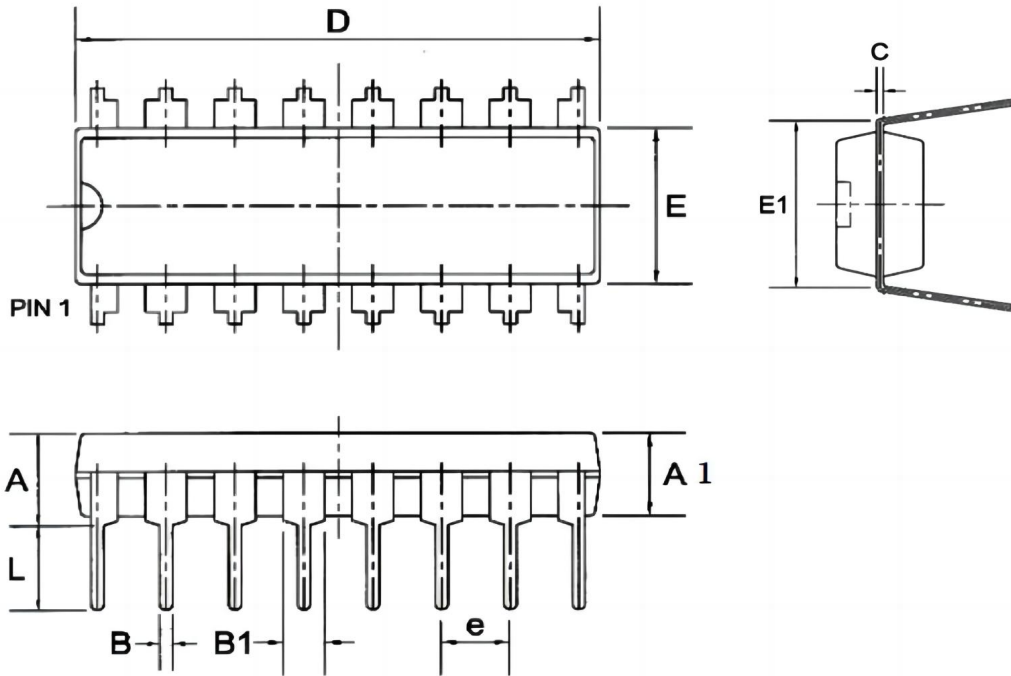

Symbol	Dimensions in Millimeters		
	Min	Nom	Max
A	--	--	4.31
A1	3.15	3.30	3.65
B	--	0.50	--
B1	--	1.6	--
C	--	0.27	--
D	19.00	19.20	19.60
E	6.20	6.50	6.60
E1	--	8.0	--
e	--	2.3	--
L	3.00	3.20	3.60

SOP16

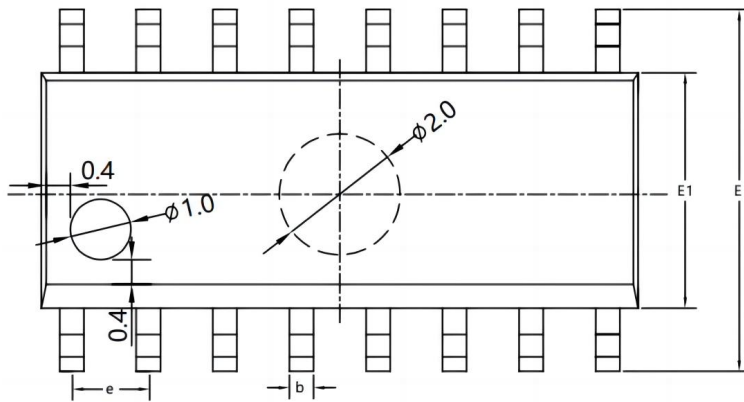
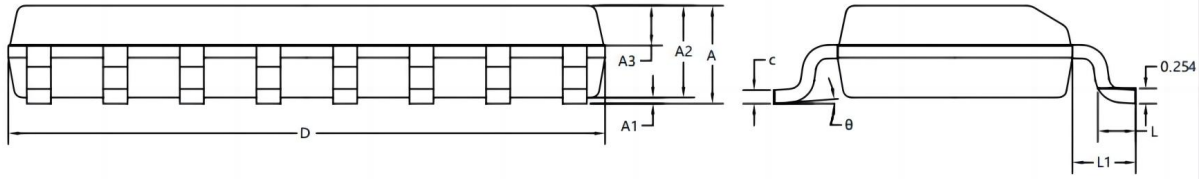

SYMBOL	MILLIMETER		
	MIN	NOM	MAX
A	1.50	1.60	1.70
A1	0.10	0.15	0.25
A2	1.40	1.45	1.50
A3	0.60	0.65	0.70
b	0.30	0.40	0.50
c	0.15	0.20	0.25
D	9.80	9.90	10.00
E	5.80	6.00	6.20
E1	3.85	3.90	3.95
e	1.27BSC		
L	0.50	0.60	0.70
L1	1.05BSC		
θ	0°	4°	8°

Statement:

- XBLW reserves the right to modify the product manual without prior notice! Before placing an order, customers need to confirm whether the obtained information is the latest version and verify the completeness of the relevant information.
- Any semi-guide product is subject to failure or malfunction under specified conditions. It is the buyer's responsibility to comply with safety standards when using XBLW products for system design and whole machine manufacturing. And take the appropriate safety measures to avoid the potential in the risk of loss of personal injury or loss of property situation!
- XBLW products have not been licensed for life support, military, and aerospace applications, and therefore XBLW is not responsible for any consequences arising from the use of this product in these areas.
- If any or all XBLW products (including technical data, services) described or contained in this document are subject to any applicable local export control laws and regulations, they may not be exported without an export license from the relevant authorities in accordance with such laws.
- The specifications of any and all XBLW products described or contained in this document specify the performance, characteristics, and functionality of said products in their standalone state, but do not guarantee the performance, characteristics, and functionality of said products installed in Customer's products or equipment. In order to verify symptoms and conditions that cannot be evaluated in a standalone device, the Customer should ultimately evaluate and test the device installed in the Customer's product device.
- XBLW documentation is only allowed to be copied without any alteration of the content and with the relevant authorization. XBLW assumes no responsibility or liability for altered documents.
- XBLW is committed to becoming the preferred semiconductor brand for customers, and XBLW will strive to provide customers with better performance and better quality products.

X-ON Electronics

Largest Supplier of Electrical and Electronic Components

Click to view similar products for [Switching Voltage Regulators](#) category:

Click to view products by [XBLW](#) manufacturer:

Other Similar products are found below :

[FAN53610AUC33X](#) [FAN53611AUC123X](#) [EN6310QA](#) [160215](#) [R3](#) [KE177614](#) [FAN53611AUC12X](#) [MAX809TTR](#) [NCV891234MW50R2G](#)
[AST1S31PUR](#) [NCP81203PMNTXG](#) [NCP81208MNTXG](#) [PCA9412AUKZ](#) [NCP81109GMNTXG](#) [NCP3235MNTXG](#) [NCP81109JMNTXG](#)
[MP2161AGJ-Z](#) [NCP81241MNTXG](#) [NTE7223](#) [NTE7222](#) [NTE7224](#) [L6986FTR](#) [MPQ4481GU-AEC1-P](#) [MP8756GD-P](#) [MPQ2171GJ-P](#)
[MPQ2171GJ-AEC1-P](#) [NJW4153U2-A-TE2](#) [MP2171GJ-P](#) [MP28160GC-Z](#) [MPM3509GQVE-AEC1-P](#) [XDPE132G5CG000XUMA1](#)
[LM60440AQRPKRQ1](#) [MP5461GC-P](#) [IW673-20](#) [NCV896530MWATXG](#) [MPQ4409GQBE-AEC1-P](#) [S-19903DA-A8T1U7](#) [S-19903CA-](#)
[A6T8U7](#) [S-19903CA-S8T1U7](#) [S-19902BA-A6T8U7](#) [S-19902CA-A6T8U7](#) [S-19902AA-A6T8U7](#) [S-19903AA-A6T8U7](#) [S-19902AA-S8T1U7](#)
[S-19902BA-A8T1U7](#) [AU8310](#) [LMR23615QDRRRQ1](#) [LMR33630APAQRNXRQ1](#) [LMR33630APCQRNXRQ1](#) [LMR36503R5RPER](#)