

General Description

The 74HC/HCT139 decodes two binary weighted address inputs ($nA0$, $nA1$) to four mutually exclusive outputs ($n\bar{Y}0$ to $n\bar{Y}3$). Each decoder features an enable input ($n\bar{E}$). When $n\bar{E}$ is HIGH all outputs are forced HIGH. The enable input can be used as the data input for a 1-to-4 demultiplexer application. Inputs include clamp diodes. This enables the use of current limiting resistors to interface inputs to voltages in excess of V_{CC} .

Features

- Input levels:
For 74HC139: CMOS level
For 74HCT139: TTL level
- Demultiplexing capability
- 2 independent 2-to-4 decoders
- Multifunction capability
- Suitable for memory decoding, data routing or code conversion
- Active LOW mutually exclusive outputs
- Specified from -40°C to $+105^{\circ}\text{C}$
- Packaging information: DIP16/SOP16/TSSOP16

ORDERING INFORMATION

DEVICE	Package Type	MARKING	Packing	Packing QTY
SN74HC139N	DIP-16	74HC139N	Tube	1000/Box
SN74HC139DTR	SOP-16	74HC139	Tape	2500/Reel
SN74HCT139DTR	SOP-16	74HCT139	Tape	2500/Reel
SN74HCT139TDTR	TSSOP-16	74HCT139	Tape	3000/Reel

Block Diagram And Pin Description

Block Diagram

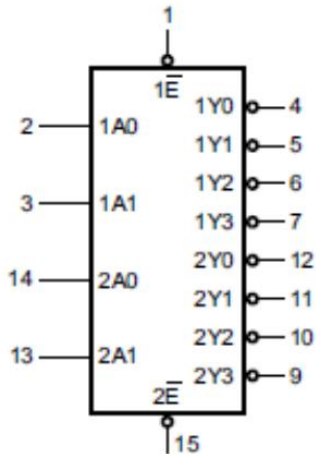

Figure 1. Logic symbol

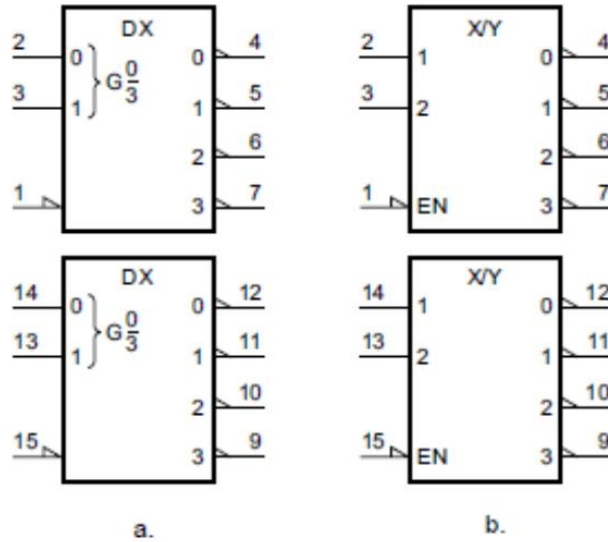

Figure 2. IEC logic symbol

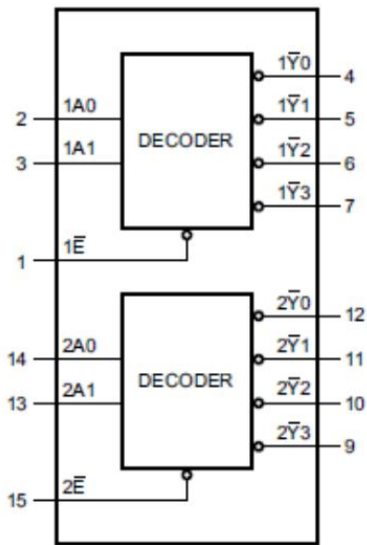

Figure 3. Functional diagram

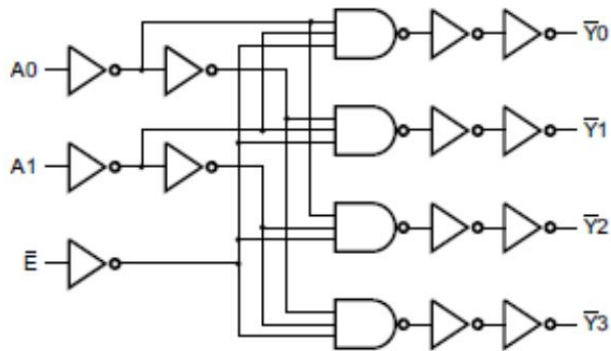
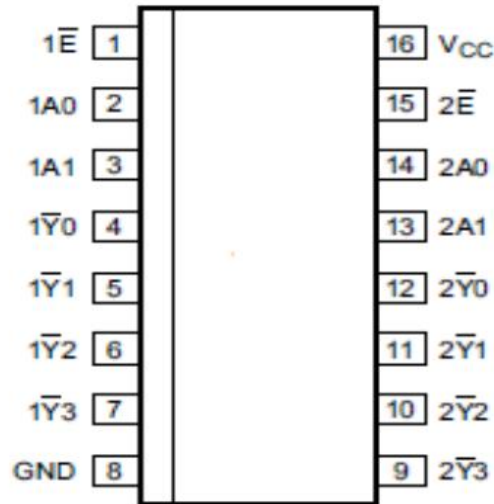

Figure 4. Logic diagram(one decodr/demultiplexer)

Pin Configurations



Pin Description

Pin No.	Pin Name	Description
1	1E	enable input(active LOW)
2	1A0	address input
3	1A1	address input
4	1Y0	output(active LOW)
5	1Y1	output(active LOW)
6	1Y2	output(active LOW)
7	1Y3	output(active LOW)
8	GND	ground(0V)
9	2Y3	output(active LOW)
10	2Y2	output(active LOW)
11	2Y1	output(active LOW)
12	2Y0	output(active LOW)
13	2A1	address input
14	2A0	address input
15	2E	enable input(active LOW)
16	VCC	Supply voltage

Function Table

Control	Input		Output			
\overline{nE}	nA1	nA0	$\overline{nY3}$	$\overline{nY2}$	$\overline{nY1}$	$\overline{nY0}$
H	X	X	H	H	H	H
L	L	L	H	H	H	L
L	L	H	H	H	L	H
L	H	L	H	L	H	H
L	H	H	L	H	H	H

Note: H=HIGH voltage level; L=LOW voltage level; X=don't care.

Electrical Parameter

Absolute Maximum Ratings (Voltages are referenced to GND (ground=0V), unless otherwise specified.)

Parameter	Symbol	Conditions	Min.	Max.	Unit
supply voltage	V_{CC}		-0.5	+7.0	V
input clamping current	I_{IK}	$V_I < -0.5V$ or $V_I > V_{CC} + 0.5V$	-	± 20	mA
output clamping current	I_{OK}	$V_O < -0.5V$ or $V_O > V_{CC} + 0.5V$	-	± 20	mA
output current	I_O	$V_O = -0.5V$ to $V_{CC} + 0.5V$	-	± 25	mA
supply current	I_{CC}	-	-	50	mA
ground current	I_{GND}	-	-50	-	mA
storage temperature	T_{stg}	-	-65	+150	°C
total power dissipation	P_{tot}	-	-	500	mW
soldering temperature	T_L	10s	DIP	245	°C
			SOP	250	

Note:

[1] For DIP16 packages: above 70°C the value of P_{tot} derates linearly with 12mW/K.

[2] For SOP16 packages: above 70°C the value of P_{tot} derates linearly with 8mW/K.

[3] For (T)SSOP16 packages: above 60°C the value of P_{tot} derates linearly with 5.5mW/K.

Recommended Operating Conditions

Parameter	Symbol	Conditions	Min.	Typ.	Max.	Unit
74HC139						
supply voltage	V_{CC}	-	2.0	5.0	6.0	V
input voltage	V_I	-	0	-	V_{CC}	V
output voltage	V_O	-	0	-	V_{CC}	V
input transition rise and fall rate	$\Delta t/\Delta V$	$V_{CC}=2.0V$	-	-	625	ns/V
		$V_{CC}=4.5V$	-	1.67	139	ns/V
		$V_{CC}=6.0V$	-	-	83	ns/V
ambient temperature	T_{amb}	-	-40	-	+105	°C
74HCT139						
supply voltage	V_{CC}	-	4.5	5.0	5.5	V
input voltage	V_I	-	0	-	V_{CC}	V
output voltage	V_O	-	0	-	V_{CC}	V
input transition rise and fall rate	$\Delta t/\Delta V$	$V_{CC}=4.5V$	-	1.67	139	ns/V
ambient temperature	T_{amb}	-	-40	-	+105	°C

Electrical Characteristics

DC Characteristics 1 ($T_{amb}=25^{\circ}C$, voltages are referenced to GND (ground=0V), unless otherwise specified.)

Parameter	Symbol	Conditions	Min.	Typ.	Max.	Unit	
74HC139							
HIGH-level input voltage	V_{IH}	$V_{CC}=2.0V$	1.5	1.2	-	V	
		$V_{CC}=4.5V$	3.15	2.4	-	V	
		$V_{CC}=6.0V$	4.2	3.2	-	V	
LOW-level input voltage	V_{IL}	$V_{CC}=2.0V$	-	0.8	0.5	V	
		$V_{CC}=4.5V$	-	2.1	1.35	V	
		$V_{CC}=6.0V$	-	2.8	1.8	V	
HIGH-level output voltage	V_{OH}	$V_I=V_{IH}$ or V_{IL}	$I_O=-20\mu A; V_{CC}=2.0V$	1.9	2.0	-	V
			$I_O=-20\mu A; V_{CC}=4.5V$	4.4	4.5	-	V
			$I_O=-20\mu A; V_{CC}=6.0V$	5.9	6.0	-	V
			$I_O=-4.0mA; V_{CC}=4.5V$	3.98	4.32	-	V
			$I_O=-5.2mA; V_{CC}=6.0V$	5.48	5.81	-	V
LOW-level output voltage	V_{OL}	$V_I=V_{IH}$ or V_{IL}	$I_O=20\mu A; V_{CC}=2.0V$	-	0	0.1	V
			$I_O=20\mu A; V_{CC}=4.5V$	-	0	0.1	V
			$I_O=20\mu A; V_{CC}=6.0V$	-	0	0.1	V
			$I_O=4.0mA; V_{CC}=4.5V$	-	0.15	0.26	V
			$I_O=5.2mA; V_{CC}=6.0V$	-	0.16	0.26	V

input leakage current	I_I	$V_I=V_{CC}$ or GND; $V_{CC}=6.0V$		-	-	± 0.1	μA
OFF-state output current	I_{OZ}	$V_I=V_H$ or V_{IL} ; $V_O=V_{CC}$ or GND; $V_{CC}=6.0V$		-	-	± 0.5	μA
supply current	I_{CC}	$V_I=V_{CC}$ or GND; $I_O=0A$; $V_{CC}=6.0V$		-	-	8.0	μA
input capacitance	C_I	-		-	3.5	-	pF
74HCT139							
HIGH-level input voltage	V_{IH}	$V_{CC}=4.5V$ to 5.5V		2.0	1.6	-	V
LOW-level input voltage	V_{IL}	$V_{CC}=4.5V$ to 5.5V		-	1.2	0.8	V
HIGH-level output voltage	V_{OH}	$V_I=V_{IH}$ or V_{IL} $V_{CC}=4.5V$	$I_O=-20\mu A$	4.4	4.5	-	V
			$I_O=-4.0\mu A$	3.98	4.32	-	V
LOW-level output voltage	V_{OL}	$V_I=V_{IH}$ or V_{IL} $V_{CC}=4.5V$	$I_O=20\mu A$	-	0	0.1	V
			$I_O=4.0\mu A$	-	0.15	0.26	V
input leakage current	I_I	$V_I=V_{CC}$ or GND; $V_{CC}=5.5V$		-	-	± 0.1	μA
OFF-state output current	I_{OZ}	$V_I=V_H$ or V_{IL} ; $V_O=V_{CC}$ or GND; $V_{CC}=5.5V$		-	-	± 0.5	μA
supply current	I_{CC}	$V_I=V_{CC}$ or GND; $I_O=0A$; $V_{CC}=5.5V$		-	-	8.0	μA
Additional Supply current	ΔI_{CC}	$V_I=V_{CC}-2.1V$; other inputs at V_{CC} or GND; $I_O=0V$; $V_{CC}=4.5V$ to 5.5V	per input pin; 1An inputs	-	70	252	μA
			per input pin; 2An inputs	-	70	252	μA
			per input pin; nE inputs	-	135	486	μA
input capacitance	C_I	-		-	3.5	-	pF

DC Characteristics 2

($T_{amb}=-40^{\circ}C$ to $+85^{\circ}C$, voltages are referenced to GND (ground=0V), unless otherwise specified.)

Parameter	Symbol	Conditions	Min.	Typ.	Max.	Unit	
74HC139							
HIGH-level input voltage	V_{IH}	$V_{CC}=2.0V$	1.5	-	-	V	
		$V_{CC}=4.5V$	3.15	-	-	V	
		$V_{CC}=6.0V$	4.2	-	-	V	
LOW-level input voltage	V_{IL}	$V_{CC}=2.0V$	-	-	0.5	V	
		$V_{CC}=4.5V$	-	-	1.35	V	
		$V_{CC}=6.0V$	-	-	1.8	V	
HIGH-level output voltage	V_{OH}	$V_I=V_{IH}$ or V_{IL}	$I_O=-20\mu A$; $V_{CC}=2.0V$	1.9	-	-	V
			$I_O=-20\mu A$; $V_{CC}=4.5V$	4.4	-	-	V
			$I_O=-20\mu A$; $V_{CC}=6.0V$	5.9	-	-	V
			$I_O=-4.0mA$; $V_{CC}=4.5V$	3.84	-	-	V

			$I_o=-5.2\text{mA}; V_{CC}=6.0\text{V}$	5.34	-	-	V
LOW-level output voltage	V_{OL}	$V_I=V_{IH}$ or V_{IL}	$I_o=20\mu\text{A}; V_{CC}=2.0\text{V}$	-	-	0.1	V
			$I_o=20\mu\text{A}; V_{CC}=4.5\text{V}$	-	-	0.1	V
			$I_o=20\mu\text{A}; V_{CC}=6.0\text{V}$	-	-	0.1	V
			$I_o=4.0\text{mA}; V_{CC}=4.5\text{V}$	-	-	0.33	V
			$I_o=5.2\text{mA}; V_{CC}=6.0\text{V}$	-	-	0.33	V
input leakage current	I_I	$V_i=V_{CC}$ or $\text{GND}; V_{CC}=6.0\text{V}$		-	-	± 1.0	μA
OFF-state output current	I_{OZ}	$V_I=V_{IH}$ or $V_{IL}; V_o=V_{CC}$ or $\text{GND}; V_{CC}=6.0\text{V}$		-	-	± 5.0	μA
supply current	I_{CC}	$V_i=V_{CC}$ or $\text{GND}; I_o=0\text{A}; V_{CC}=6.0\text{V}$		-	-	80	μA
74HCT139							
HIGH-level input voltage	V_{IH}	$V_{CC}=4.5\text{V}$ to 5.5V		2.0	-	-	V
LOW-level input voltage	V_{IL}	$V_{CC}=4.5\text{V}$ to 5.5V		-	-	0.8	V
HIGH-level output voltage	V_{OH}	$V_I=V_{IH}$ or V_{IL} $V_{CC}=4.5\text{V}$	$I_o=-20\mu\text{A}$	4.4	-	-	V
			$I_o=-4.0\text{mA}$	3.84	-	-	V
LOW-level output voltage	V_{OL}	$V_I=V_{IH}$ or V_{IL} $V_{CC}=4.5\text{V}$	$I_o=20\mu\text{A}$	-	-	0.1	V
			$I_o=4.0\text{mA}$	-	-	0.33	V
input leakage current	I_I	$V_i=V_{CC}$ or $\text{GND}; V_{CC}=5.5\text{V}$		-	-	± 1.0	μA
OFF-state output current	I_{OZ}	$V_I=V_{IH}$ or $V_{IL}; V_o=V_{CC}$ or $\text{GND}; V_{CC}=5.5\text{V}$		-	-	± 5.0	μA
supply current	I_{CC}	$V_i=V_{CC}$ or $\text{GND}; I_o=0\text{A}; V_{CC}=5.5\text{V}$		-	-	80	μA
additional supply current	ΔI_{CC}	$V_I=V_{CC}-2.1\text{V};$ other inputs at V_{CC} or $\text{GND}; I_o=0\text{V};$ $V_{CC}=4.5\text{V}$ to 5.5V	per input pin; 1An inputs	-	-	315	μA
			per input pin; 2An inputs	-	-	315	μA
			per input pin; $n\bar{E}$ inputs	-	-	607.5	μA

DC Characteristics 3

($T_{amb}=-40^\circ\text{C}$ to $+105^\circ\text{C}$, voltages are referenced to GND (ground=0V), unless otherwise specified.)

Parameter	Symbol	Conditions		Min.	Typ.	Max.	Unit
74HC139							
HIGH-level input voltage	V_{IH}	$V_{CC}=2.0\text{V}$		1.5	-	-	V
		$V_{CC}=4.5\text{V}$		3.15	-	-	V
		$V_{CC}=6.0\text{V}$		4.2	-	-	V
LOW-level input voltage	V_{IL}	$V_{CC}=2.0\text{V}$		-	-	0.5	V
		$V_{CC}=4.5\text{V}$		-	-	1.35	V
		$V_{CC}=6.0\text{V}$		-	-	1.8	V
HIGH-level	V_{OH}	$V_I=V_{IH}$ or V_{IL}	$I_o=-20\mu\text{A}; V_{CC}=2.0\text{V}$	1.9	-	-	V

output voltage			$I_o=-20\mu A; V_{CC}=4.5V$	4.4	-	-	V
			$I_o=-20\mu A; V_{CC}=6.0V$	5.9	-	-	V
			$I_o=-4.0mA; V_{CC}=4.5V$	3.7	-	-	V
			$I_o=-5.2mA; V_{CC}=6.0V$	5.2	-	-	V
LOW-level output voltage	V_{OL}	$V_I=V_{IH}$ or V_{IL}	$I_o=20\mu A; V_{CC}=2.0V$	-	-	0.1	V
			$I_o=20\mu A; V_{CC}=4.5V$	-	-	0.1	V
			$I_o=20\mu A; V_{CC}=6.0V$	-	-	0.1	V
			$I_o=4.0mA; V_{CC}=4.5V$	-	-	0.4	V
			$I_o=5.2mA; V_{CC}=6.0V$	-	-	0.4	V
input leakage current	I_I	$V_i=V_{CC}$ or $GND; V_{CC}=6.0V$		-	-	± 1.0	μA
OFF-state output current	I_{OZ}	$V_i=V_{IH}$ or $V_{IL}; V_o=V_{CC}$ or $GND; V_{CC}=6.0V$		-	-	± 10	μA
supply current	I_{CC}	$V_i=V_{CC}$ or $GND; I_o=0A; V_{CC}=6.0V$		-	-	160	μA
74HCT139							
HIGH-level input voltage	V_{IH}	$V_{CC}=4.5V$ to $5.5V$		2.0	-	-	V
LOW-level input voltage	V_{IL}	$V_{CC}=4.5V$ to $5.5V$		-	-	0.8	V
HIGH-level output voltage	V_{OH}	$V_i=V_{IH}$ or V_{IL} $V_{CC}=4.5V$	$I_o=-20\mu A$	4.4	-	-	V
			$I_o=-4.0mA$	3.7	-	-	V
LOW-level output voltage	V_{OL}	$V_i=V_{IH}$ or V_{IL} $V_{CC}=4.5V$	$I_o=20\mu A$	-	-	0.1	V
			$I_o=4.0mA$	-	-	0.4	V
input leakage current	I_I	$V_i=V_{CC}$ or $GND; V_{CC}=5.5V$		-	-	± 1.0	μA
OFF-state output current	I_{OZ}	$V_i=V_{IH}$ or $V_{IL}; V_o=V_{CC}$ or $GND; V_{CC}=5.5V$		-	-	± 10	μA
supply current	I_{CC}	$V_i=V_{CC}$ or $GND; I_o=0A; V_{CC}=5.5V$		-	-	160	μA
additional supply current	ΔI_{CC}	$V_i=V_{CC}-2.1V$; other inputs at V_{CC} or $GND; I_o=0V$; $V_{CC}=4.5V$ to $5.5V$	per input pin; 1An inputs	-	-	343	μA
			per input pin; 2An inputs	-	-	343	μA
			per input pin; $n\bar{E}$ inputs	-	-	661.5	μA

AC Characteristics 1 (Tamb=25°C, GND=0V, CL=50pF unless otherwise specified.)

Parameter	Symbol	Conditions	Min.	Typ.	Max.	Unit	
74HC139							
Propagation delay	t_{pd}	nAn to $n\bar{Y}n$ see Figure6 ^[1]	$V_{CC}=2.0V$	-	39	145	ns
			$V_{CC}=4.5V$	-	14	29	ns
			$V_{CC}=5.0V; CL=15pF$	-	11	-	ns
			$V_{CC}=6.0V$	-	11	25	ns
		$n\bar{E}$ to $n\bar{Y}n$	$V_{CC}=2.0V$	-	33	135	ns

		see Figure7 ^[2]	V _{CC} =4.5V	-	12	27	ns
			V _{CC} =5.0V;C _L =15pF	-	10	-	ns
			V _{CC} =6.0V	-	10	23	ns
transition time	t _t	n \bar{Y} _n ;see Figure6 and Figure7 ^[2]	V _{CC} =2.0V	-	19	75	ns
			V _{CC} =4.5V	-	7	15	ns
			V _{CC} =6.0V	-	6	13	ns
power dissipation capacitance	C _{PD}	C _L =50pF;f=1MHz;V _I =GND to V _{CC} ^[3]		-	42	-	pF
74HCT139							
Propagation delay	t _{pd}	nA _n to n \bar{Y} _n see Figure6 ^[1]	V _{CC} =4.5V	-	16	34	ns
			V _{CC} =5.0V;C _L =15pF	-	13	-	ns
		n \bar{E} to n \bar{Y} _n see Figure7 ^[2]	V _{CC} =4.5V	-	16	34	ns
			V _{CC} =5.0V;C _L =15pF	-	13	-	ns
transition time	t _t	n \bar{Y} _n ;V _{CC} =4.5V; see Figure6 and Figure7 ^[2]		-	7	15	ns
power dissipation capacitance	C _{PD}	C _L =50pF;f=1MHz;V _I =GND to V _{CC} -1.5V ^[3]		-	44	-	pF

Note:

[1]t_{pd} is the same as t_{PLH} and t_{PHL}.

[2]t_t is the same as t_{THL} and t_{TLH}.

[3]C_{PD} is used to determine the dynamic power dissipation (P_D in uW).

$$P_D = C_{PD} \times V_{CC}^2 \times f_i \times N + \sum (C_L \times V_{CC}^2 \times f_o) \text{ where:}$$

f_i=input frequency in MHz;

f_o=output frequency in MHz;

C_L=output load capacitance in pF;

V_{CC}=supply voltage in V;

N=number of inputs switching;

$\sum (C_L \times V_{CC}^2 \times f)$ =sum of outputs.

AC Characteristics 2 (T_{amb}=-40°C to +85°C,GND=0V,C_L=50pF, unless otherwise specified.)

Parameter	Symbol	Conditions	Min.	Typ.	Max.	Unit	
74HC139							
Propagation delay	t _{pd}	nA _n to n \bar{Y} _n see Figure6 ^[1]	V _{CC} =2.0V	-	-	180	ns
			V _{CC} =4.5V	-	-	36	ns
			V _{CC} =6.0V	-	-	31	ns
		n \bar{E} to n \bar{Y} _n see Figure7 ^[1]	V _{CC} =2.0V	-	-	170	ns
			V _{CC} =4.5V	-	-	34	ns
			V _{CC} =6.0V	-	-	29	ns

transition time	t_t	$n\bar{Y}_n$; see Figure6 and Figure7 ^[2]	$V_{CC}=2.0V$	-	-	95	ns
			$V_{CC}=4.5V$	-	-	19	ns
			$V_{CC}=6.0V$	-	-	16	ns
74HCT139							
Propagation delay	t_{pd}	nA_n to $n\bar{Y}_n$ see Figure6 ^[1]	$V_{CC}=4.5V$	-	-	43	ns
		$n\bar{E}$ to $n\bar{Y}_n$ see Figure7 ^[1]	$V_{CC}=4.5V$	-	-	43	ns
transition time	t_t	$n\bar{Y}_n; V_{CC}=4.5V$; see Figure6 and Figure7 ^[2]		-	-	19	ns

Note:

[1] t_{pd} is the same as t_{PLH} and t_{PHL} .

[2] t_t is the same as t_{THL} and t_{TLH} .

AC Characteristics 3 ($T_{amb}=-40^{\circ}C$ to $+105^{\circ}C$, $GND=0V$, $C_L=50pF$, unless otherwise specified.)

Parameter	Symbol	Conditions	Min.	Typ.	Max.	Unit	
74HC139							
Propagation delay	t_{pd}	nA_n to $n\bar{Y}_n$ see Figure6 ^[1]	$V_{CC}=2.0V$	-	-	220	ns
			$V_{CC}=4.5V$	-	-	44	ns
			$V_{CC}=6.0V$	-	-	38	ns
		$n\bar{E}$ to $n\bar{Y}_n$ see Figure7 ^[1]	$V_{CC}=2.0V$	-	-	205	ns
			$V_{CC}=4.5V$	-	-	41	ns
			$V_{CC}=6.0V$	-	-	35	ns
transition time	t_t	$n\bar{Y}_n$; see Figure6 and Figure7 ^[2]	$V_{CC}=2.0V$	-	-	110	ns
			$V_{CC}=4.5V$	-	-	22	ns
			$V_{CC}=6.0V$	-	-	19	ns
74HCT139							
Propagation delay	t_{pd}	nA_n to $n\bar{Y}_n$ see Figure6 ^[1]	$V_{CC}=4.5V$	-	-	51	ns
		$n\bar{E}$ to $n\bar{Y}_n$ see Figure7 ^[1]	$V_{CC}=4.5V$	-	-	51	ns
transition time	t_t	$n\bar{Y}_n; V_{CC}=4.5V$; see Figure6 and Figure7 ^[2]		-	-	22	ns

Note:

[1] t_{pd} is the same as t_{PLH} and t_{PHL} .

[2] t_t is the same as t_{THL} and t_{TLH} .

Testing Circuit

AC Testing Circuit

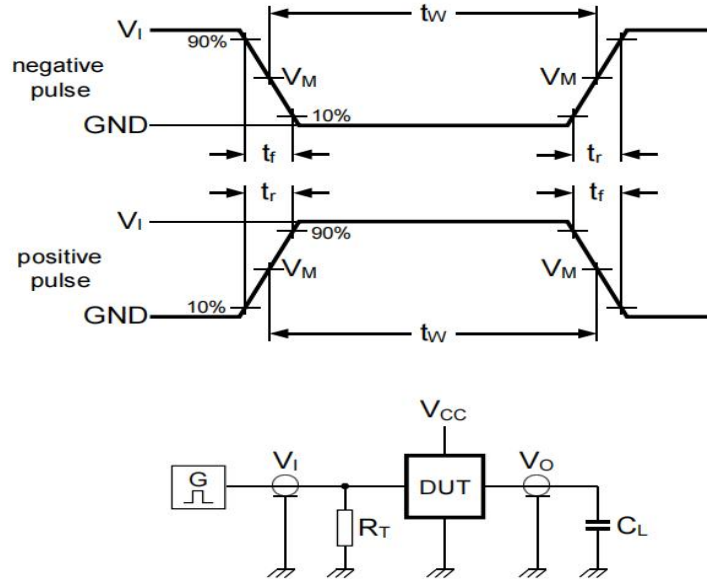

Figure 5. Test circuit for measuring switching times

Definitions for test circuit:

C_L =Load capacitance including jig and probe capacitance.

R_T =Termination resistance should be equal to the output impedance Z_o of the pulse generator.

R_L =Load resistance.

S1=Test selection switch.

AC Testing Waveforms

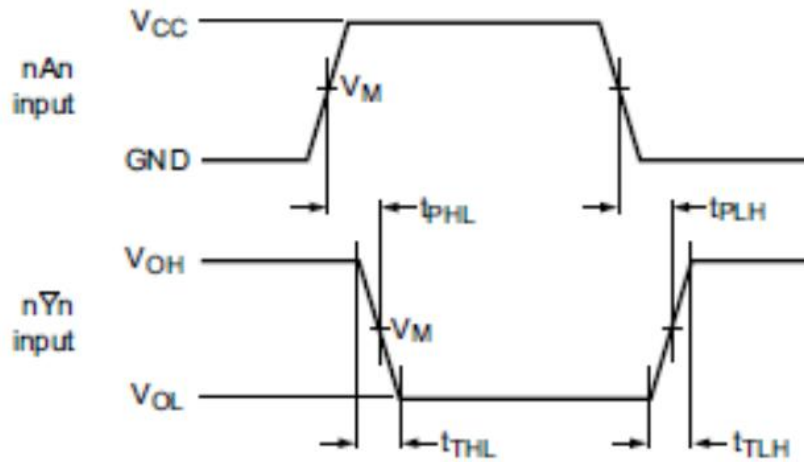

Figure 6. Propagation delay input (nAn) to output (nYn) and transition time output (nYn)

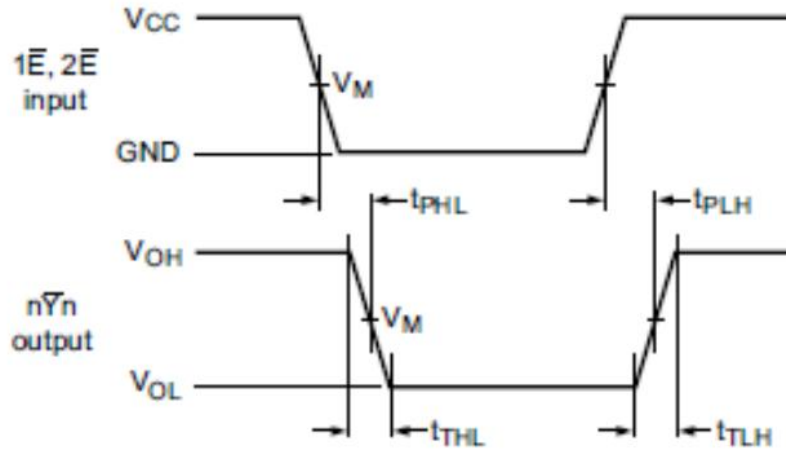

Figure 7. Propagation delay enable input (\overline{nE}) to output ($n\overline{Yn}$) and transition time output ($n\overline{Yn}$)

Measurement Points

Type	Input	Output
	V_M	V_M
74HC139	$0.5 \times V_{CC}$	$0.5 \times V_{CC}$
74HCT139	1.3V	1.3V

Test Data

Type	Input		Load		S1 position		
	V_I	t_r, t_f	C_L	R_L	t_{PLH}, t_{PHL}	t_{PZH}, t_{PHZ}	t_{PZL}, t_{PLZ}
74HC139	V_{CC}	6.0ns	15pF, 50pF	1K Ω	open	GND	V_{CC}
74HCT139	3.0V	6.0ns	15pF, 50pF	1K Ω	open	GND	V_{CC}

Package Information

DIP16

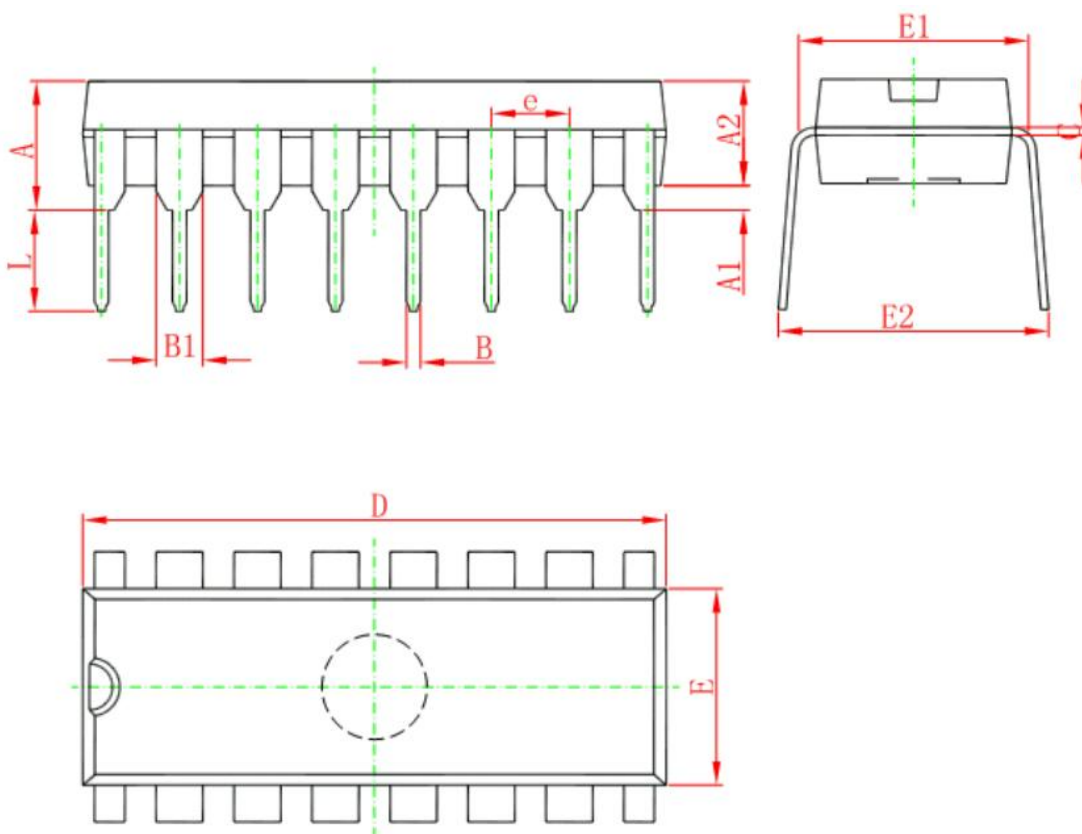

Symbol	Dimensions In Millimeters		Dimensions In Inches	
	Min	Max	Min	Max
A	3.710	4.310	0.146	0.170
A1	0.510		0.020	
A2	3.200	3.600	0.126	0.142
B	0.380	0.570	0.015	0.022
B1	1.524(BSC)		0.060(BSC)	
C	0.204	0.360	0.008	0.014
D	18.800	19.200	0.740	0.756
E	6.200	6.600	0.244	0.260
E1	7.320	7.920	0.288	0.312
e	2.540(BSC)		0.100(BSC)	
L	3.000	3.600	0.118	0.142
E2	8.400	9.000	0.331	0.354

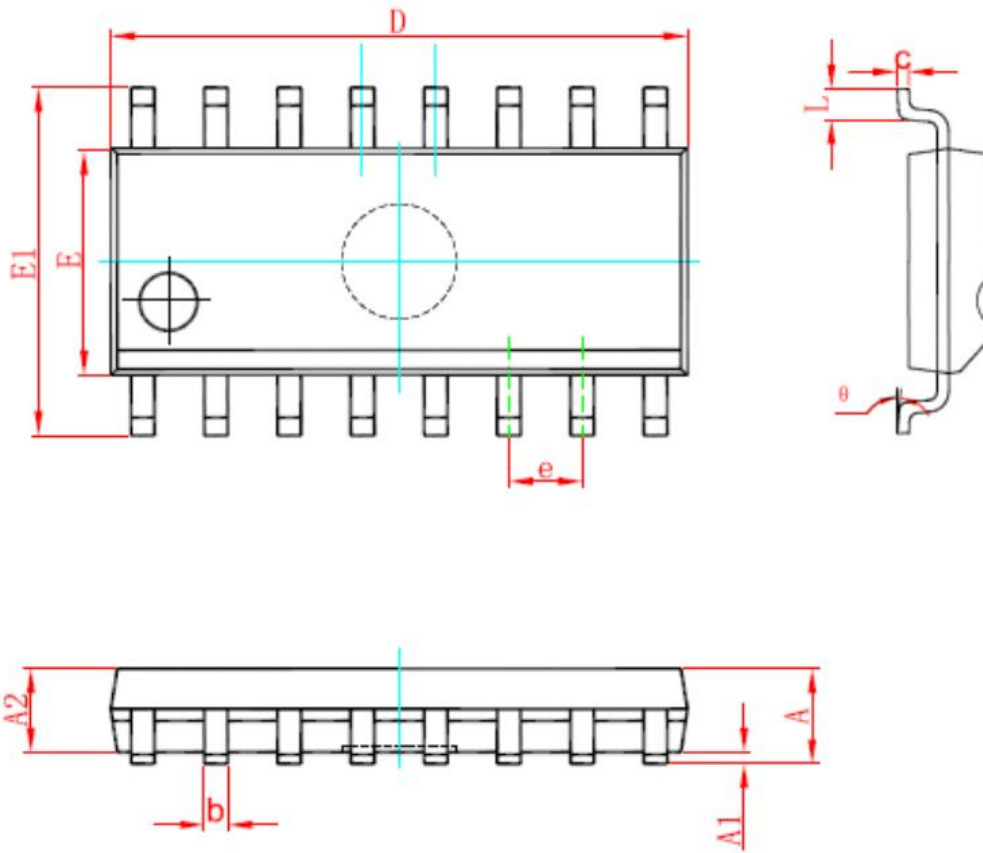

Symbol	Dimensions In Millimeters		Dimensions In Inches	
	Min	Max	Min	Max
A	1.350	1.750	0.053	0.069
A1	0.100	0.250	0.004	0.010
A2	1.350	1.550	0.053	0.061
b	0.330	0.510	0.013	0.020
C	0.170	0.250	0.007	0.010
D	9.800	10.200	0.386	0.402
E	3.800	4.000	0.150	0.157
E1	5.800	6.200	0.228	0.244
e	1.270(BSC)		0.050(BSC)	
L	0.400	1.270	0.016	0.050
θ	0°	8°	0°	8°

TSSOP16

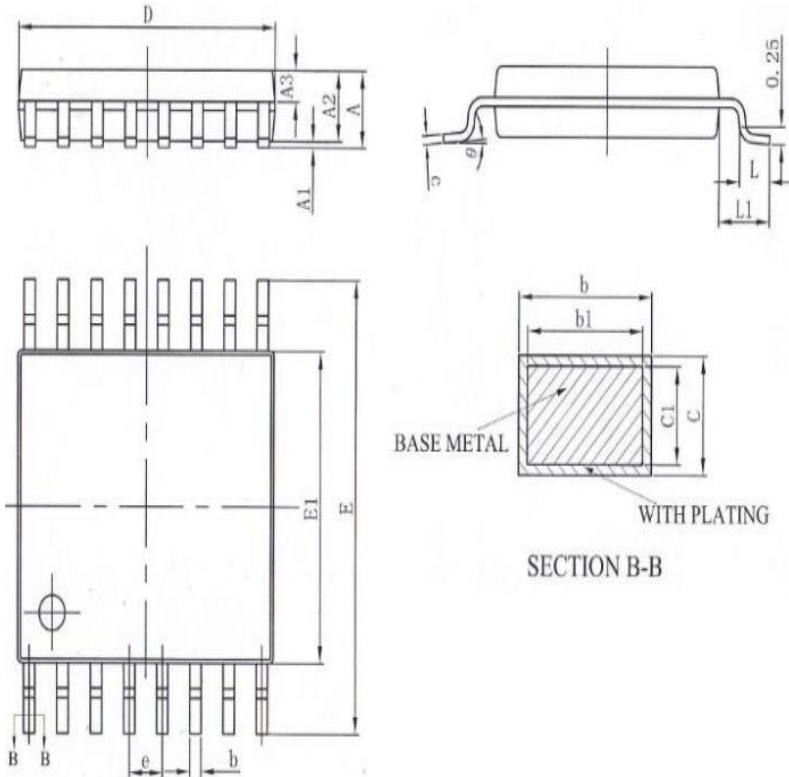

SYMBOL	MILLIMETER		
	MIN	NOM	MAX
A	-	-	1.20
A1	0.05	-	0.15
A2	0.90	1.00	1.05
A3	0.39	0.44	0.49
b	0.20	-	0.28
b1	0.19	0.22	0.25
c	0.13	-	0.17
c1	0.12	0.13	0.14
D	4.90	5.00	5.10
E	6.20	6.40	6.60
E1	4.30	4.40	4.50
e	0.65BSC		
L	0.45	0.60	0.75
L1	1.00BSC		
θ	0	-	8°

Statements And Notes

Part name	Hazardous substances or Elements									
	Lead and lead compounds	Mercury and mercury compounds	Cadmium and cadmium compounds	Hexavalent chromium compounds	Polybrominated biphenyls	Polybrominated biphenyl ethers	Dibutyl phthalate	Butyl benzyl phthalate	Di-2-ethylhexyl phthalate	Diisobutyl phthalate
Lead frame	○	○	○	○	○	○	○	○	○	○
Plastic resin	○	○	○	○	○	○	○	○	○	○
Chip	○	○	○	○	○	○	○	○	○	○
The lead	○	○	○	○	○	○	○	○	○	○
Plastic sheet installed	○	○	○	○	○	○	○	○	○	○
explanation	○: Indicates that the content of hazardous substances or elements in the detection limit of the following the SJ/T11363-2006 standard. ×: Indicates that the content of hazardous substances or elements exceeding the SJ/T11363-2006 Standard limit requirements									

Statement:

- ◇ Shenzhen xinbole electronics co., ltd. reserves the right to change the product specifications, without notice!
Before placing an order, the customer needs to confirm whether the information obtained is the latest version, and verify the integrity of the relevant information.
- ◇ Any semiconductor product is liable to fail or malfunction under certain conditions, and the buyer shall be responsible for complying with safety standards in the system design and whole machine manufacturing using Shenzhen xinbole electronics co., ltd products, and take appropriate security measures to avoid the potential risk of failure may result in personal injury or property losses of the situation occurred!
- ◇ Product performance is never ending, Shenzhen xinbole electronics co., ltd will be dedicated to provide customers with better performance, better quality of integrated circuit products.

X-ON Electronics

Largest Supplier of Electrical and Electronic Components

Click to view similar products for [Encoders, Decoders, Multiplexers & Demultiplexers](#) category:

Click to view products by [XBLW](#) manufacturer:

Other Similar products are found below :

[MC74HC163ADTG](#) [74HC253N](#) [NLV74VHC1G01DFT1G](#) [NLVHCT4851ADTR2G](#) [NLV14028BDR2G](#) [COMX-CAR-210](#) [SN74LS148N](#)
[PI3B3251LE](#) [PI3B3251QE](#) [NLV74HC4851AMNTWG](#) [MC74LVX257DG](#) [M74HCT4851ADWR2G](#) [NL7SZ19DBVT1G](#) [PI5C3253LEX](#)
[MC74HC251ADTG](#) [MC74ACT138NG](#) [NB3L8533DTR2G](#) [NLV74AC157DR2G](#) [74HC138DT](#) [74HC153DT](#) [74HC238DT](#) [74HC151DT](#)
[ADS131M02IRUKR](#) [CBMG709ATS16](#) [74HC238N](#) [HT74HC154ARWZ](#) [RS2G139XS16-G](#) [74HCT251D](#) [74HC138T](#) [U74HC138G-S16-R](#)
[AIP74HCT138SA.TB](#) [XD74C922](#) [RS1G157XC6](#) [74HC151M/TR](#) [AiP74HC237TA16.TB](#) [AIP74HC138TA16.TB](#) [74HC138DRG](#)
[AiP74LVC138TA16.TB](#) [CD4511BDRG](#) [AiP74LVC157TA16.TB](#) [SN74HC42N\(LX\)](#) [SN74LS157N\(LX\)](#) [SN74LS42N](#) [TC4053BFT\(EL,N\)](#)
[74VHC4052AFT\(BE\)](#) [TC74VHC138FK\(EL,K\)](#) [TC74HC151AF\(EL,F\)](#) [SN74HC145DR\(LX\)](#) [SN74HC139DR\(LX\)](#) [CD4028BM\(LX\)](#)