

General Description

The 74HC/HCT151 are 8-bit multiplexer with eight binary inputs (I0 to I7), three select inputs (S0 to S2) and an enable input (\bar{E}). One of the eight binary inputs is selected by the select inputs and routed to the complementary outputs (Y and \bar{Y}). A HIGH on \bar{E} forces the output Y LOW and output Y HIGH. Inputs also include clamp diodes that enable the use of current limiting resistors to interface inputs to voltages in excess of V_{CC} .

Features

- Input levels:
For 74HC151: CMOS level
For 74HCT151: TTL level
- Low-power dissipation
- Non-inverting data path
- Specified from -40°C to +105°C
- Packaging information: DIP16/SOP16/TSSOP16

ORDERING INFORMATION

DEVICE	Package Type	MARKING	Packing	Packing QTY
SN74HC151N	DIP-16	74HC151N	Tube	1000/Box
SN74HC151DTR	SOP-16	74HC151	Tape	2500/Reel
SN74HCT151DTR	SOP-16	74HCT151	Tape	2500/Reel
SN74HCT151TDTR	TSSOP-16	74HCT151	Tape	3000/Reel

Block Diagram And Pin Description

Block Diagram

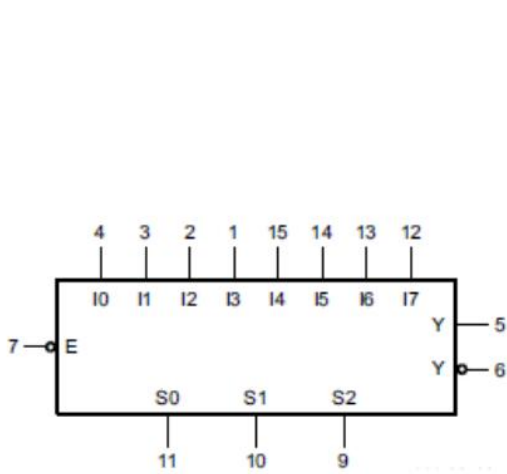

Figure 1. Logic symbol

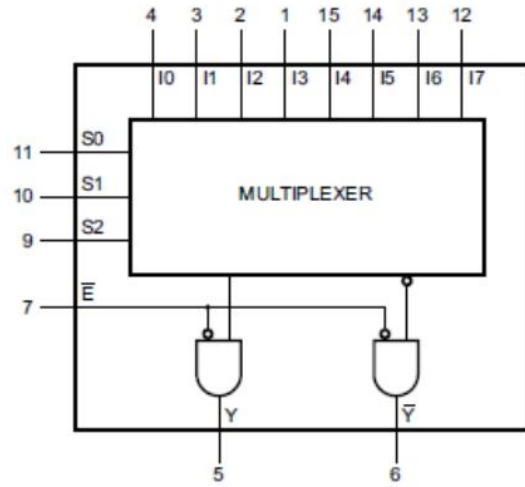

Figure 2. Functional diagram

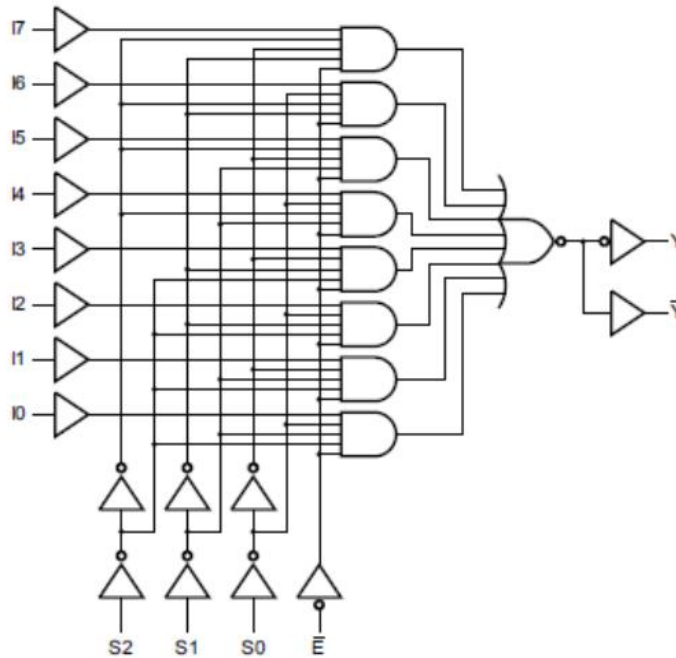
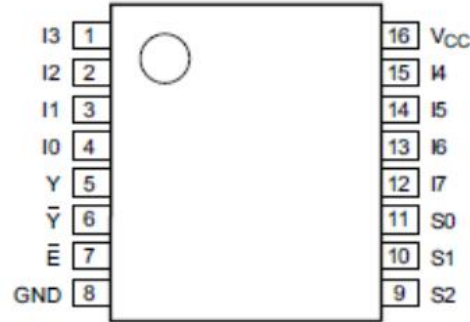

Figure 3. Logic diagram

Pin Configurations



Pin Description

Pin No.	Pin Name	Description
1	I3	data input
2	I2	data input
3	I1	data input
4	I0	data input
5	Y	multiplexer output
6	\bar{Y}	complementary multiplexer output
7	\bar{E}	enable input(active LOW)
8	GND	ground(0V)
9	S2	common data select input
10	S1	common data select input
11	S0	common data select input
12	I7	data input
13	I6	data input
14	I5	data input
15	I4	data input
16	V _{CC}	supply voltage

Function Table

Input												Output	
\bar{E}	S2	S1	S0	I0	I1	I2	I3	I4	I5	I6	I7	Y	\bar{Y}
H	X	X	X	X	X	X	X	X	X	X	X	H	L
L	L	L	L	L	X	X	X	X	X	X	X	H	L
L	L	L	L	H	X	X	X	X	X	X	X	L	H
L	L	L	H	X	L	X	X	X	X	X	X	H	L

L	L	L	H	X	H	X	X	X	X	X	X	L	H
L	L	H	L	X	X	L	X	X	X	X	X	H	L
L	L	H	L	X	X	H	X	X	X	X	X	L	H
L	L	H	H	X	X	X	L	X	X	X	X	H	L
L	L	H	H	X	X	X	H	X	X	X	X	L	H
L	H	L	L	X	X	X	X	L	X	X	X	H	L
L	H	L	L	X	X	X	X	H	X	X	X	L	H
L	H	L	H	X	X	X	X	X	L	X	X	H	L
L	H	L	H	X	X	X	X	X	H	X	X	L	H
L	H	H	L	X	X	X	X	X	X	L	X	H	L
L	H	H	L	X	X	X	X	X	X	H	X	L	H
L	H	H	H	X	X	X	X	X	X	X	L	H	L
L	H	H	H	X	X	X	X	X	X	X	H	L	H

Note: H=HIGH voltage level; L=LOW voltage level; X=don't care.

Electrical Parameter

Absolute Maximum Ratings (Voltages are referenced to GND (ground=0V), unless otherwise specified.)

Parameter	Symbol	Conditions	Min.	Max.	Unit
supply voltage	V_{CC}	-	-0.5	+7.0	V
input clamping current	I_{IK}	$V_I < -0.5V$ or $V_I > V_{CC}+0.5V$	-	± 20	mA
output clamping current	I_{OK}	$V_O < -0.5V$ or $V_O > V_{CC}+0.5V$	-	± 20	mA
output current	I_O	$V_O = -0.5V$ to $(V_{CC} + 0.5V)$	-	± 25	mA
supply current	I_{CC}	-	-	50	mA
ground current	I_{GND}	-	-50	-	mA
storage temperature	T_{stg}	-	-65	+150	°C
total power dissipation	P_{tot}	-	-	500	mW
soldering temperature	T_L	10s	DIP	245	°C
			SOP	250	

Note:

[1] For DIP16 packages: above 70°C the value of P_{tot} derates linearly with 12mW/K.

[2] For SOP16 packages: above 70°C the value of P_{tot} derates linearly with 8mW/K.

[3] For (T)SSOP16 packages: above 60°C the value of P_{tot} derates linearly with 5.5mW/K.

Recommended Operating Conditions

Parameter	Symbol	Conditions	Min.	Typ.	Max.	Unit
74HC151						
supply voltage	V_{CC}	-	2.0	5.0	6.0	V
input voltage	V_I	-	0	-	V_{CC}	V
output voltage	V_O	-	0	-	V_{CC}	V
input transition rise and fall rate	$\Delta t/\Delta V$	$V_{CC}=2.0V$	-	-	625	ns/V
		$V_{CC}=4.5V$	-	1.67	139	ns/V
		$V_{CC}=6.0V$	-	-	83	ns/V
ambient temperature	T_{amb}	-	-40	-	+105	°C
74HCT151						
supply voltage	V_{CC}	-	4.5	5.0	5.5	V
input voltage	V_I	-	0	-	V_{CC}	V
output voltage	V_O	-	0	-	V_{CC}	V
input transition rise and fall rate	$\Delta t/\Delta V$	$V_{CC}=4.5V$	-	1.67	139	ns/V
ambient temperature	T_{amb}	-	-40	-	+105	°C

Electrical Characteristics

DC Characteristics 1 ($T_{amb}=25^{\circ}C$, voltages are referenced to GND (ground=0V), unless otherwise specified.)

Parameter	Symbol	Conditions	Min.	Typ.	Max.	Unit	
74HC151							
HIGH-level input voltage	V_{IH}	$V_{CC}=2.0V$	1.5	1.2	-	V	
		$V_{CC}=4.5V$	3.15	2.4	-	V	
		$V_{CC}=6.0V$	4.2	3.2	-	V	
LOW-level input voltage	V_{IL}	$V_{CC}=2.0V$	-	0.8	0.5	V	
		$V_{CC}=4.5V$	-	2.1	1.35	V	
		$V_{CC}=6.0V$	-	2.8	1.8	V	
HIGH-level output voltage	V_{OH}	$V_I=V_{IH}$ or V_{IL}	$I_O=-20\mu A; V_{CC}=2.0V$	1.9	2.0	-	V
			$I_O=-20\mu A; V_{CC}=4.5V$	4.4	4.5	-	V
			$I_O=-20\mu A; V_{CC}=6.0V$	5.9	6.0	-	V
			$I_O=-4.0mA; V_{CC}=4.5V$	3.98	4.32	-	V
			$I_O=-5.2mA; V_{CC}=6.0V$	5.48	5.81	-	V
LOW-level output voltage	V_{OL}	$V_I=V_{IH}$ or V_{IL}	$I_O=20\mu A; V_{CC}=2.0V$	-	0	0.1	V
			$I_O=20\mu A; V_{CC}=4.5V$	-	0	0.1	V

			$I_o=20\mu A; V_{CC}=6.0V$	-	0	0.1	V
			$I_o=4.0mA; V_{CC}=4.5V$	-	0.15	0.26	V
			$I_o=5.2mA; V_{CC}=6.0V$	-	0.16	0.26	V
input leakage current	I_i	$V_i=V_{CC}$ or GND; $V_{CC}=6.0V$		-	-	± 0.1	μA
supply current	I_{CC}	$V_i=V_{CC}$ or GND; $I_o=0A; V_{CC}=6.0V$		-	-	8.0	μA
input apacitance	C_i	-		-	3.5	-	pF
74HCT151							
HIGH-level input voltage	V_{IH}	$V_{CC}=4.5V$ to 5.5V		2.0	1.6	-	V
LOW-level input voltage	V_{IL}	$V_{CC}=4.5V$ to 5.5V		-	1.2	0.8	V
HIGH-level output voltage	V_{OH}	$V_i=V_{IH}$ or V_{IL} $V_{CC}=4.5V$	$I_o=-20\mu A$	4.4	4.5	-	V
			$I_o=-4.0\mu A$	3.98	4.32	-	V
LOW-level output voltage	V_{OL}	$V_i=V_{IH}$ or V_{IL} $V_{CC}=4.5V$	$I_o=20\mu A$	-	0	0.1	V
			$I_o=4.0\mu A$	-	0.15	0.26	V
input leakage current	I_i	$V_i=V_{CC}$ or GND; $V_{CC}=5.5V$		-	-	± 0.1	μA
supply current	I_{CC}	$V_i=V_{CC}$ or GND; $I_o=0A; V_{CC}=5.5V$		-	-	8.0	μA
Additional Supply current	ΔI_{CC}	$V_i=V_{CC}-2.1V$; other inputs at V_{CC} or GND; $I_o=0V$; $V_{CC}=4.5V$ to 5.5V	per input pin; I_n inputs	-	45	162	μA
			per input pin; \bar{E} inputs	-	30	108	μA
			per input pin; S_n input	-	150	540	μA
input apacitance	C_i	-		-	3.5	-	pF

DC Characteristics 2

($T_{amb}=-40^\circ C$ to $+85^\circ C$, voltages are referenced to GND (ground=0V), unless otherwise specified.)

Parameter	Symbol	Conditions	Min.	Typ.	Max.	Unit	
74HC151							
HIGH-level input voltage	V_{IH}	$V_{CC}=2.0V$	1.5	-	-	V	
		$V_{CC}=4.5V$	3.15	-	-	V	
		$V_{CC}=6.0V$	4.2	-	-	V	
LOW-level input voltage	V_{IL}	$V_{CC}=2.0V$	-	-	0.5	V	
		$V_{CC}=4.5V$	-	-	1.35	V	
		$V_{CC}=6.0V$	-	-	1.8	V	
HIGH-level output voltage	V_{OH}	$V_i=V_{IH}$ or V_{IL}	$I_o=-20\mu A; V_{CC}=2.0V$	1.9	-	-	V
			$I_o=-20\mu A; V_{CC}=4.5V$	4.4	-	-	V

			$I_o=-20\mu A; V_{CC}=6.0V$	5.9	-	-	V
			$I_o=-4.0mA; V_{CC}=4.5V$	3.84	-	-	V
			$I_o=-5.2mA; V_{CC}=6.0V$	5.34	-	-	V
LOW-level output voltage	V_{OL}	$V_i=V_{IH}$ or V_{IL}	$I_o=20\mu A; V_{CC}=2.0V$	-	-	0.1	V
			$I_o=20\mu A; V_{CC}=4.5V$	-	-	0.1	V
			$I_o=20\mu A; V_{CC}=6.0V$	-	-	0.1	V
			$I_o=4.0mA; V_{CC}=4.5V$	-	-	0.33	V
			$I_o=5.2mA; V_{CC}=6.0V$	-	-	0.33	V
input leakage current	I_i	$V_i=V_{CC}$ or $GND; V_{CC}=6.0V$		-	-	± 1.0	μA
supply current	I_{CC}	$V_i=V_{CC}$ or $GND; I_o=0A; V_{CC}=6.0V$		-	-	80	μA
74HCT151							
HIGH-level input voltage	V_{IH}	$V_{CC}=4.5V$ to $5.5V$		2.0	-	-	V
LOW-level input voltage	V_{IL}	$V_{CC}=4.5V$ to $5.5V$		-	-	0.8	V
HIGH-level output voltage	V_{OH}	$V_i=V_{IH}$ or V_{IL} $V_{CC}=4.5V$	$I_o=-20\mu A$	4.4	-	-	V
			$I_o=-4.0mA$	3.84	-	-	V
LOW-level output voltage	V_{OL}	$V_i=V_{IH}$ or V_{IL} $V_{CC}=4.5V$	$I_o=20\mu A$	-	-	0.1	V
			$I_o=4.0mA$	-	-	0.33	V
input leakage current	I_i	$V_i=V_{CC}$ or $GND; V_{CC}=5.5V$		-	-	± 1.0	μA
supply current	I_{CC}	$V_i=V_{CC}$ or $GND; I_o=0A; V_{CC}=5.5V$		-	-	80	μA
additional supply current	ΔI_{CC}	$V_i=V_{CC}-2.1V$; other inputs at V_{CC} or $GND; I_o=0V$; $V_{CC}=4.5V$ to $5.5V$	per input pin; I_n inputs	-	-	203	μA
			per input pin; \bar{E} inputs	-	-	135	μA
			per input pin; S_n input	-	-	675	μA

DC Characteristics 3

($T_{amb}=-40^{\circ}C$ to $+105^{\circ}C$, voltages are referenced to GND (ground=0V), unless otherwise specified.)

Parameter	Symbol	Conditions	Min.	Typ.	Max.	Unit
74HC151						
HIGH-level input voltage	V_{IH}	$V_{CC}=2.0V$	1.5	-	-	V
		$V_{CC}=4.5V$	3.15	-	-	V
		$V_{CC}=6.0V$	4.2	-	-	V
LOW-level input voltage	V_{IL}	$V_{CC}=2.0V$	-	-	0.5	V
		$V_{CC}=4.5V$	-	-	1.35	V



		$V_{CC}=6.0V$		-	-	1.8	V
HIGH-level output voltage	V_{OH}	$V_I=V_{IH}$ or V_{IL}	$I_O=-20\mu A; V_{CC}=2.0V$	1.9	-	-	V
			$I_O=-20\mu A; V_{CC}=4.5V$	4.4	-	-	V
			$I_O=-20\mu A; V_{CC}=6.0V$	5.9	-	-	V
			$I_O=-4.0mA; V_{CC}=4.5V$	3.7	-	-	V
			$I_O=-5.2mA; V_{CC}=6.0V$	5.2	-	-	V
LOW-level output voltage	V_{OL}	$V_I=V_{IH}$ or V_{IL}	$I_O=20\mu A; V_{CC}=2.0V$	-	-	0.1	V
			$I_O=20\mu A; V_{CC}=4.5V$	-	-	0.1	V
			$I_O=20\mu A; V_{CC}=6.0V$	-	-	0.1	V
			$I_O=4.0mA; V_{CC}=4.5V$	-	-	0.4	V
			$I_O=5.2mA; V_{CC}=6.0V$	-	-	0.4	V
input leakage current	I_I	$V_I=V_{CC}$ or $GND; V_{CC}=6.0V$		-	-	± 1.0	μA
supply current	I_{CC}	$V_I=V_{CC}$ or $GND; I_O=0A; V_{CC}=6.0V$		-	-	160	μA
74HCT151							
HIGH-level input voltage	V_{IH}	$V_{CC}=4.5V$ to $5.5V$		2.0	-	-	V
LOW-level input voltage	V_{IL}	$V_{CC}=4.5V$ to $5.5V$		-	-	0.8	V
HIGH-level output voltage	V_{OH}	$V_I=V_{IH}$ or V_{IL} $V_{CC}=4.5V$	$I_O=-20\mu A$	4.4	-	-	V
			$I_O=-4.0mA$	3.7	-	-	V
LOW-level output voltage	V_{OL}	$V_I=V_{IH}$ or V_{IL} $V_{CC}=4.5V$	$I_O=20\mu A$	-	-	0.1	V
			$I_O=4.0mA$	-	-	0.4	V
input leakage current	I_I	$V_I=V_{CC}$ or $GND; V_{CC}=5.5V$		-	-	± 1.0	μA
supply current	I_{CC}	$V_I=V_{CC}$ or $GND; I_O=0A; V_{CC}=5.5V$		-	-	160	μA
additional supply current	ΔI_{CC}	$V_I=V_{CC}-2.1V$; other inputs at V_{CC} or $GND; I_O=0V$; $V_{CC}=4.5V$ to $5.5V$	per input pin; In inputs	-	-	221	μA
			per input pin; \bar{E} inputs	-	-	147	μA
			per input pin; Sn input	-	-	735	μA

AC Characteristics 1 (Tamb=25°C, GND =0V, CL=50pF, unless otherwise specified.)

Parameter	Symbol	Conditions	Min.	Typ.	Max.	Unit	
74HC151							
Propagation delay	t _{pd}	In to Y see Figure5 ^[1]	V _{CC} =2.0V	-	52	170	ns
			V _{CC} =4.5V	-	19	34	ns
			V _{CC} =5.0V;CL=15pF	-	17	-	ns
			V _{CC} =6.0V	-	15	29	ns
		In to \bar{Y} see Figure5 ^[1]	V _{CC} =2.0V	-	58	185	ns
			V _{CC} =4.5V	-	21	37	ns
			V _{CC} =5.0V;CL=15pF	-	17	-	ns
			V _{CC} =6.0V	-	17	31	ns
		Sn to Y see Figure6 ^[1]	V _{CC} =2.0V	-	61	185	ns
			V _{CC} =4.5V	-	22	37	ns
			V _{CC} =5.0V;CL=15pF	-	19	-	ns
			V _{CC} =6.0V	-	18	31	ns
		Sn to \bar{Y} see Figure6 ^[1]	V _{CC} =2.0V	-	61	205	ns
			V _{CC} =4.5V	-	22	41	ns
			V _{CC} =5.0V;CL=15pF	-	19	-	ns
			V _{CC} =6.0V	-	18	35	ns
		\bar{E} to Y see Figure6	V _{CC} =2.0V	-	41	125	ns
			V _{CC} =4.5V	-	15	25	ns
			V _{CC} =5.0V;CL=15pF	-	12	-	ns
			V _{CC} =6.0V	-	12	21	ns
		\bar{E} to \bar{Y} see Figure6	V _{CC} =2.0V	-	47	145	ns
			V _{CC} =4.5V	-	17	29	ns
			V _{CC} =5.0V;CL=15pF	-	14	-	ns
			V _{CC} =6.0V	-	14	25	ns
transition time	t _t	Y, \bar{Y} see Figure5 ^[2]	V _{CC} =2.0V	-	19	75	ns
			V _{CC} =4.5V	-	7	15	ns
			V _{CC} =6.0V	-	6	13	ns
power dissipation capacitance	C _{PD}	C _L =50pF;f=1MHz;V _I =GND to V _{CC} ^[3]	-	40	-	pF	
74HCT151							
Propagation	t _{pd}	In to Y	V _{CC} =4.5V	-	22	38	ns

delay		see Figure5 ^[1]	$V_{CC}=5.0V; C_L=15pF$	-	19	-	ns
		In to \bar{Y} see Figure5 ^[1]	$V_{CC}=4.5V$	-	22	38	ns
			$V_{CC}=5.0V; C_L=15pF$	-	19	-	ns
		Sn to Y see Figure6 ^[1]	$V_{CC}=4.5V$	-	23	41	ns
			$V_{CC}=5.0V; C_L=15pF$	-	20	-	ns
		Sn to \bar{Y} see Figure6 ^[1]	$V_{CC}=4.5V$	-	25	-43	ns
			$V_{CC}=5.0V; C_L=15pF$	-	20	-	ns
		\bar{E} to Y see Figure6	$V_{CC}=4.5V$	-	16	29	ns
			$V_{CC}=5.0V; C_L=15pF$	-	13	-	ns
		\bar{E} to \bar{Y} see Figure6	$V_{CC}=4.5V$	-	21	36	ns
$V_{CC}=5.0V; C_L=15pF$	-		18	-	ns		
transition time	t_t	$Y, \bar{Y}; V_{CC}=4.5V; \text{see Figure5}^{[2]}$		-	7	15	ns
power dissipation capacitance	C_{PD}	$C_L=50pF; f=1MHz; V_I=GND \text{ to } V_{CC}-1.5V^{[3]}$		-	40	-	pF

Note:

[1] t_{pd} is the same as t_{PLH} and t_{PHL} .

[2] t_t is the same as t_{THL} and t_{TLH} .

[3] C_{PD} is used to determine the dynamic power dissipation (P_D in uW).

$P_D=C_{PD} \times V_{CC}^2 \times f_i \times N + \sum(C_L \times V_{CC}^2 \times f_o)$ where:

f_i =input frequency in MHz;

f_o =output frequency in MHz;

C_L =output load capacitance in pF;

V_{CC} =supply voltage in V;

N =number of inputs switching;

$\sum(C_L \times V_{CC}^2 \times f)$ =sum of outputs.

AC Characteristics 2 ($T_{amb}=-40^\circ C$ to $+85^\circ C, GND=0V, C_L=50pF$, unless otherwise specified.)

Parameter	Symbol	Conditions	Min.	Typ.	Max.	Unit	
74HC151							
Propagation delay	t_{pd}	In to Y see Figure5 ^[1]	$V_{CC}=2.0V$	-	-	215	ns
			$V_{CC}=4.5V$	-	-	43	ns
			$V_{CC}=6.0V$	-	-	37	ns
		In to \bar{Y} see Figure5 ^[1]	$V_{CC}=2.0V$	-	-	230	ns
			$V_{CC}=4.5V$	-	-	46	ns

		Sn to Y see Figure6 ^[1]	V _{CC} =6.0V	-	-	39	ns
			V _{CC} =2.0V	-	-	230	ns
			V _{CC} =4.5V	-	-	46	ns
			V _{CC} =6.0V	-	-	39	ns
		Sn to \bar{Y} see Figure6 ^[1]	V _{CC} =2.0V	-	-	255	ns
			V _{CC} =4.5V	-	-	51	ns
			V _{CC} =6.0V	-	-	43	ns
		\bar{E} to Y see Figure6	V _{CC} =2.0V	-	-	155	ns
			V _{CC} =4.5V	-	-	31	ns
			V _{CC} =6.0V	-	-	26	ns
		\bar{E} to \bar{Y} see Figure6	V _{CC} =2.0V	-	-	180	ns
			V _{CC} =4.5V	-	-	36	ns
V _{CC} =6.0V	-		-	31	ns		
transition time	t _t	Y, \bar{Y} see Figure5 ^[2]	V _{CC} =2.0V	-	-	95	ns
			V _{CC} =4.5V	-	-	19	ns
			V _{CC} =6.0V	-	-	16	ns
74HCT151							
Propagation delay	t _{pd}	In to Y see Figure5 ^[1]	V _{CC} =4.5V	-	-	48	ns
		In to \bar{Y} see Figure5 ^[1]	V _{CC} =4.5V	-	-	48	ns
		Sn to Y see Figure6 ^[1]	V _{CC} =4.5V	-	-	51	ns
		Sn to \bar{Y} see Figure6 ^[1]	V _{CC} =4.5V	-	-	54	ns
		\bar{E} to Y see Figure6	V _{CC} =4.5V	-	-	36	ns
		\bar{E} to \bar{Y} see Figure6	V _{CC} =4.5V	-	-	45	ns
transition time	t _t	Y, \bar{Y} ; V _{CC} =4.5V; see Figure5 ^[2]		-	-	19	ns

Note:

[1] t_{pd} is the same as t_{PLH} and t_{PHL}.

[2] t_t is the same as t_{THL} and t_{TLH}.

AC Characteristics 3 (T_{amb}=-40°C to +105°C, GND=0V, C_L=50pF, unless otherwise specified.)

Parameter	Symbol	Conditions	Min.	Typ.	Max.	Unit	
74HC151							
Propagation delay	t _{pd}	In to Y see Figure5 ^[1]	V _{CC} =2.0V	-	-	255	ns
			V _{CC} =4.5V	-	-	51	ns



		In to \bar{Y} see Figure5 ^[1]	$V_{CC}=6.0V$	-	-	43	ns		
			$V_{CC}=2.0V$	-	-	280	ns		
			$V_{CC}=4.5V$	-	-	56	ns		
		Sn to Y see Figure6 ^[1]	$V_{CC}=6.0V$	-	-	48	ns		
			$V_{CC}=2.0V$	-	-	280	ns		
			$V_{CC}=4.5V$	-	-	56	ns		
		Sn to \bar{Y} see Figure6 ^[1]	$V_{CC}=6.0V$	-	-	48	ns		
			$V_{CC}=2.0V$	-	-	310	ns		
			$V_{CC}=4.5V$	-	-	62	ns		
		\bar{E} to Y see Figure6	$V_{CC}=6.0V$	-	-	53	ns		
			$V_{CC}=2.0V$	-	-	190	ns		
			$V_{CC}=4.5V$	-	-	38	ns		
		\bar{E} to \bar{Y} see Figure6	$V_{CC}=6.0V$	-	-	32	ns		
			$V_{CC}=2.0V$	-	-	220	ns		
			$V_{CC}=4.5V$	-	-	44	ns		
		transition time	t_t	Y, \bar{Y} see Figure5 ^[2]	$V_{CC}=6.0V$	-	-	38	ns
					$V_{CC}=2.0V$	-	-	110	ns
					$V_{CC}=4.5V$	-	-	22	ns
		74HCT151							
		Propagation delay	t_{pd}	In to Y see Figure5 ^[1]	$V_{CC}=4.5V$	-	-	57	ns
				In to \bar{Y} see Figure5 ^[1]	$V_{CC}=4.5V$	-	-	57	ns
Sn to Y see Figure6 ^[1]	$V_{CC}=4.5V$			-	-	62	ns		
Sn to \bar{Y} see Figure6 ^[1]	$V_{CC}=4.5V$			-	-	65	ns		
\bar{E} to Y see Figure6	$V_{CC}=4.5V$			-	-	44	ns		
\bar{E} to \bar{Y} see Figure6	$V_{CC}=4.5V$			-	-	54	ns		
transition time	t_t	Y, \bar{Y} ; $V_{CC}=4.5V$; see Figure5 ^[2]		-	-	22	ns		

Note:

[1] t_{pd} is the same as t_{PLH} and t_{PHL} .

[2] t_t is the same as t_{THL} and t_{TLH} .

Testing Circuit

AC Testing Circuit

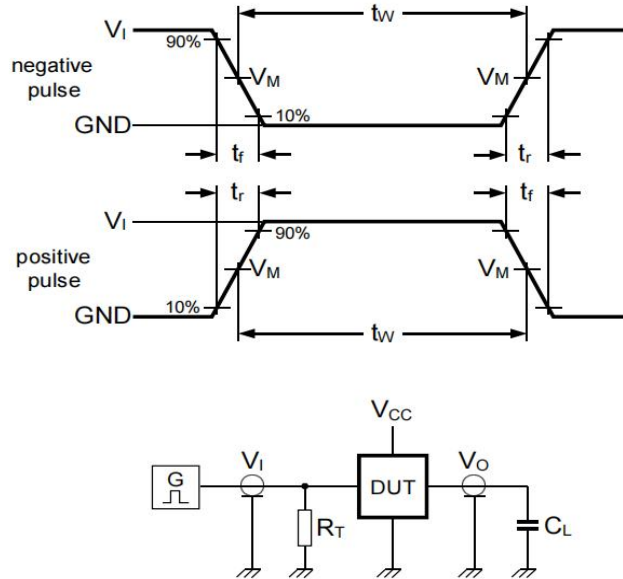

Figure 4. Test circuit for measuring switching times

Definitions for test circuit:

C_L = Load capacitance including jig and probe capacitance.

R_T = Termination resistance should be equal to the output impedance Z_o of the pulse generator.

AC Testing Waveforms

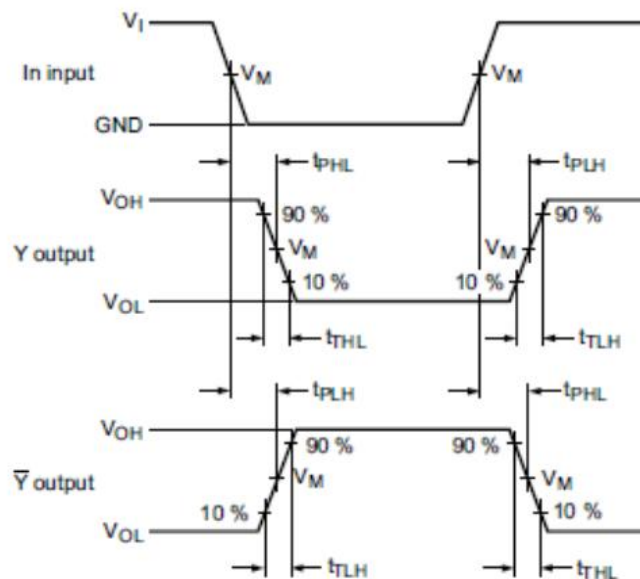

Figure 5. Propagation delay input (In) to output (Y, \bar{Y}) and the output (Y, \bar{Y}) transition time

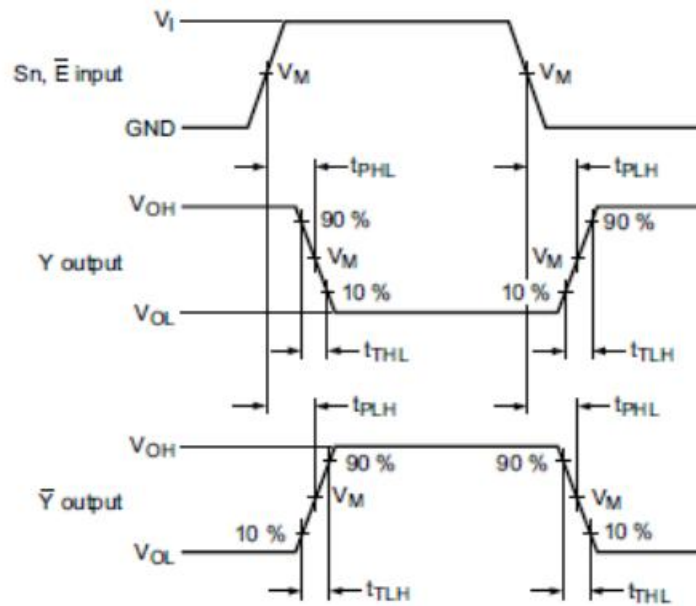

Figure 6. Propagation delay input (S_n, \bar{E}) to output (Y, \bar{Y}) and output (Y, \bar{Y}) transitions time

Measurement Points

Type	Input	Output
	V_M	V_M
74HC151	$0.5 \times V_{CC}$	$0.5 \times V_{CC}$
74HCT151	1.3V	1.3V

Test Data

Type	Input		Load	Test
	V_I	t_r, t_f	C_L	
74HC151	V_{CC}	6.0ns	15pF, 50pF	t_{PHL}, t_{PLH}
74HCT151	3.0V	6.0ns	15pF, 50pF	t_{PHL}, t_{PLH}

Package Information

DIP16

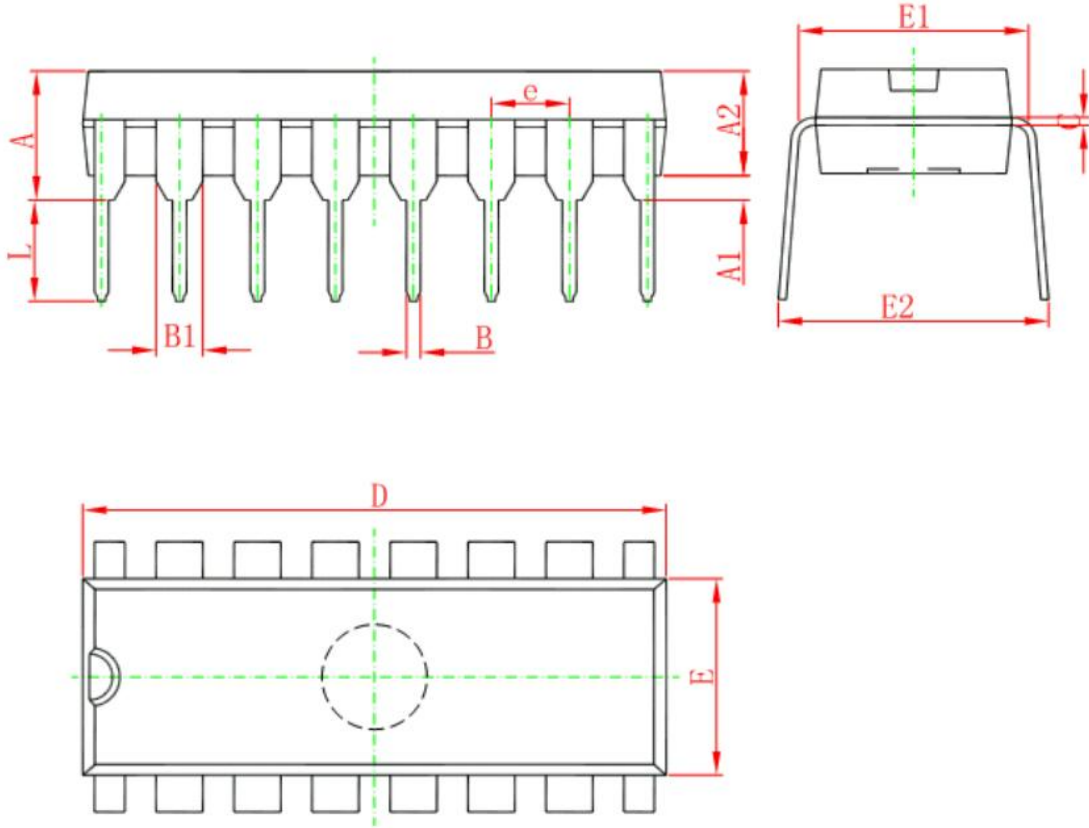

Symbol	Dimensions In Millimeters		Dimensions In Inches	
	Min	Max	Min	Max
A	3.710	4.310	0.146	0.170
A1	0.510		0.020	
A2	3.200	3.600	0.126	0.142
B	0.380	0.570	0.015	0.022
B1	1.524(BSC)		0.060(BSC)	
C	0.204	0.360	0.008	0.014
D	18.800	19.200	0.740	0.756
E	6.200	6.600	0.244	0.260
E1	7.320	7.920	0.288	0.312
e	2.540(BSC)		0.100(BSC)	
L	3.000	3.600	0.118	0.142

E2	8.400	9.000	0.331	0.354
----	-------	-------	-------	-------

SOP16

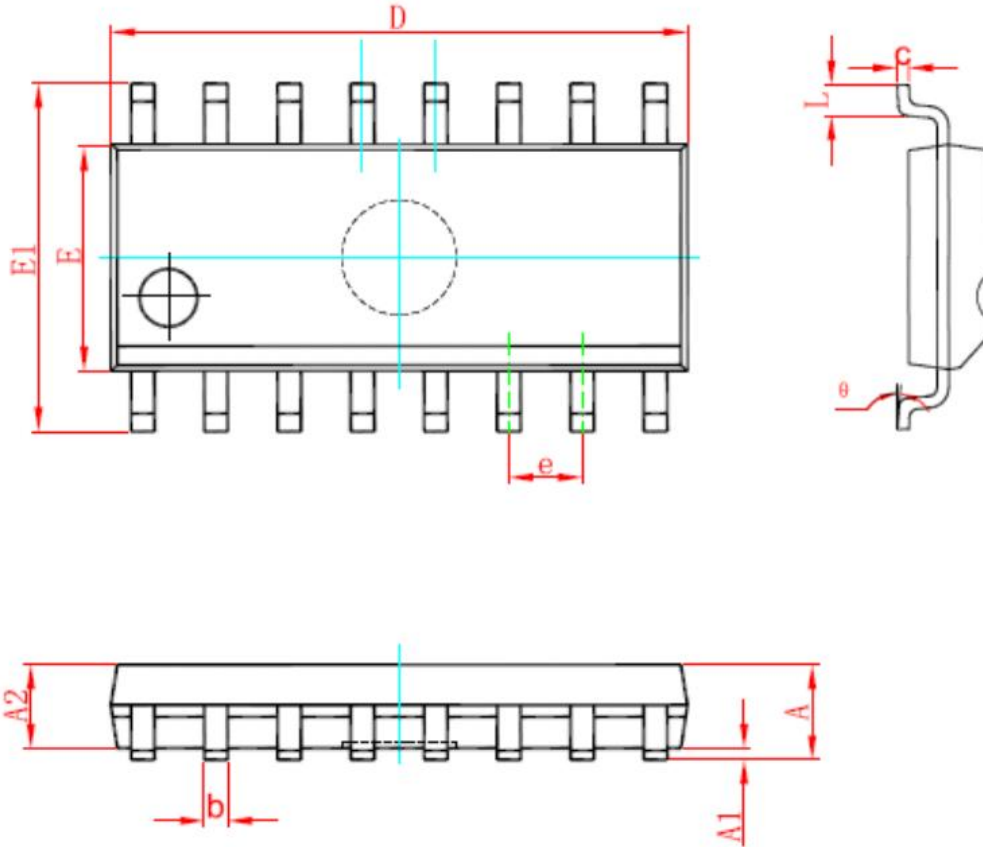

Symbol	Dimensions In Millimeters		Dimensions In Inches	
	Min	Max	Min	Max
A	1.350	1.750	0.053	0.069
A1	0.100	0.250	0.004	0.010
A2	1.350	1.550	0.053	0.061
b	0.330	0.510	0.013	0.020
C	0.170	0.250	0.007	0.010
D	9.800	10.200	0.386	0.402
E	3.800	4.000	0.150	0.157
E1	5.800	6.200	0.228	0.244
e	1.270(BSC)		0.050(BSC)	
L	0.400	1.270	0.016	0.050
θ	0°	8°	0°	8°

TSSOP16

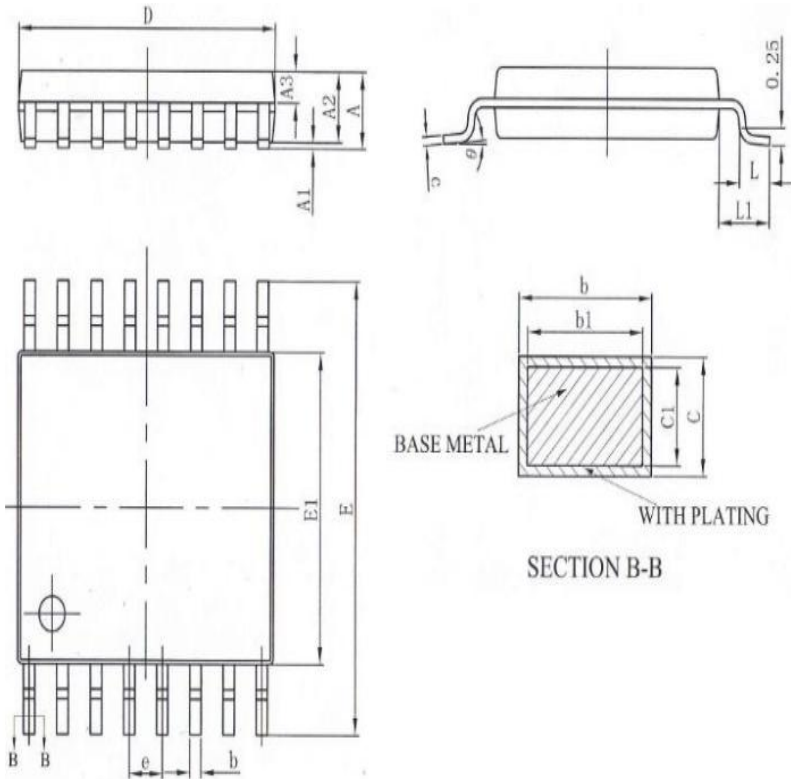

SYMBOL	MILLIMETER		
	MIN	NOM	MAX
A	-	-	1.20
A1	0.05	-	0.15
A2	0.90	1.00	1.05
A3	0.39	0.44	0.49
b	0.20	-	0.28
b1	0.19	0.22	0.25
c	0.13	-	0.17
c1	0.12	0.13	0.14
D	4.90	5.00	5.10
E	6.20	6.40	6.60
E1	4.30	4.40	4.50
e	0.65BSC		
L	0.45	0.60	0.75
L1	1.00BSC		
θ	0	-	8°

Statements And Notes

Part name	Hazardous substances or Elements									
	Lead and lead compounds	Mercury and mercury compounds	Cadmium and cadmium compounds	Hexavalent chromium compounds	Polybrominated biphenyls	Polybrominated biphenyl ethers	Dibutyl phthalate	Butyl benzyl phthalate	Di-2-ethylhexyl phthalate	Diisobutyl phthalate
Lead frame	○	○	○	○	○	○	○	○	○	○
Plastic resin	○	○	○	○	○	○	○	○	○	○
Chip	○	○	○	○	○	○	○	○	○	○
The lead	○	○	○	○	○	○	○	○	○	○
Plastic sheet installed	○	○	○	○	○	○	○	○	○	○
explanation	○: Indicates that the content of hazardous substances or elements in the detection limit of the following the SJ/T11363-2006 standard. ×: Indicates that the content of hazardous substances or elements exceeding the SJ/T11363-2006 Standard limit requirements									

Statement:

- ✧ Shenzhen xinbole electronics co., ltd. reserves the right to change the product specifications, without notice!
Before placing an order, the customer needs to confirm whether the information obtained is the latest version, and verify the integrity of the relevant information.
- ✧ Any semiconductor product is liable to fail or malfunction under certain conditions, and the buyer shall be responsible for complying with safety standards in the system design and whole machine manufacturing using Shenzhen xinbole electronics co., ltd products, and take appropriate security measures to avoid the potential risk of failure may result in personal injury or property losses of the situation occurred!
- ✧ Product performance is never ending, Shenzhen xinbole electronics co., ltd will be dedicated to provide customers with better performance, better quality of integrated circuit products.



X-ON Electronics

Largest Supplier of Electrical and Electronic Components

Click to view similar products for [Encoders, Decoders, Multiplexers & Demultiplexers](#) category:

Click to view products by [XBLW](#) manufacturer:

Other Similar products are found below :

[MC74HC163ADTG](#) [74HC253N](#) [NLV74VHC1G01DFT1G](#) [NLVHCT4851ADTR2G](#) [NLV14028BDR2G](#) [COMX-CAR-210](#) [SN74LS148N](#)
[PI3B3251LE](#) [PI3B3251QE](#) [NLV74HC4851AMNTWG](#) [MC74LVX257DG](#) [M74HCT4851ADWR2G](#) [NL7SZ19DBVT1G](#) [PI5C3253LEX](#)
[MC74HC251ADTG](#) [MC74ACT138NG](#) [NB3L8533DTR2G](#) [NLV74AC157DR2G](#) [74HC138DT](#) [74HC153DT](#) [74HC238DT](#) [74HC151DT](#)
[ADS131M02IRUKR](#) [CBMG709ATS16](#) [74HC238N](#) [HT74HC154ARWZ](#) [RS2G139XS16-G](#) [74HCT251D](#) [74HC138T](#) [U74HC138G-S16-R](#)
[AIP74HCT138SA.TB](#) [XD74C922](#) [SN74LVC1G19DBVR\(UMW\)](#) [RS1G157XC6](#) [74HC151M/TR](#) [AiP74HC237TA16.TB](#)
[AIP74HC138TA16.TB](#) [74HC138DRG](#) [AiP74LVC138TA16.TB](#) [CD4511BDRG](#) [AiP74LVC157TA16.TB](#) [SN74HC42N\(LX\)](#)
[SN74LS157N\(LX\)](#) [SN74LS42N](#) [TC4053BFT\(EL,N\)](#) [74VHC4052AFT\(BE\)](#) [TC74VHC138FK\(EL,K\)](#) [TC74HC151AF\(EL,F\)](#)
[SN74HC145DR\(LX\)](#) [SN74HC139DR\(LX\)](#)