

General Description

The SN74HC/HCT160 is a synchronous presettable decade counter with an internal look-ahead carry. Synchronous operation is provided by having all flip-flops clocked simultaneously on the positive-going edge of the clock (CP). The outputs (Q0 to Q3) of the counters may be preset HIGH or LOW. A LOW at the parallel enable input (\overline{PE}) disables the counting action and causes the data at the data inputs (D0 to D3) to be loaded into the counter on the positive-going edge of the clock. Preset takes place regardless of the levels at count enable inputs (CEP and CET). A LOW at the master reset input (\overline{MR}) sets Q0 to Q3 LOW regardless of the levels at input pins CP, \overline{PE} , CET and CEP (thus providing an asynchronous clear function). The look-ahead carry simplifies serial cascading of the counters. Both CEP and CET must be HIGH to count. The CET input is fed forward to enable the terminal count output (TC). The TC output thus enabled will produce a HIGH output pulse of a duration approximately equal to a HIGH output of Q0. This pulse can be used to enable the next cascaded stage. The maximum clock frequency for the cascaded counters is determined by the CP to TC propagation delay and CEP to CP set-up time, according to the following formula: $f_{max}=1/(t_{p(max)}(CP\ to\ TC)+t_{SU}(CEP\ to\ CP))$

Inputs include clamp diodes. This enables the use of current limiting resistors to interface inputs to voltages in excess of V_{CC} .

Features

- Input levels:
For SN74HC160: CMOS level
For SNSN74HCT160: TTL level
- Synchronous counting and loading
- 2 count enable inputs for n-bit cascading
- Asynchronous reset
- Positive-edge triggered clock
- Specified from -40°C to +105°C
- Packaging information: DIP16/SOP16/TSSOP16

ORDERING INFORMATION

DEVICE	Package Type	MARKING	Packing	Packing QTY
SN74HC160N	DIP-16	74HC160N	Tube	1000/Box
SN74HC160DTR	SOP-16	74HC160	Tape	2500/Reel
SN74HCT160DTR	SOP-16	74HCT160	Tape	2500/Reel
SN74HCT160TDTR	TSSOP-16	74HCT160	Tape	3000/Reel

Block Diagram And Pin Description

Block Diagram

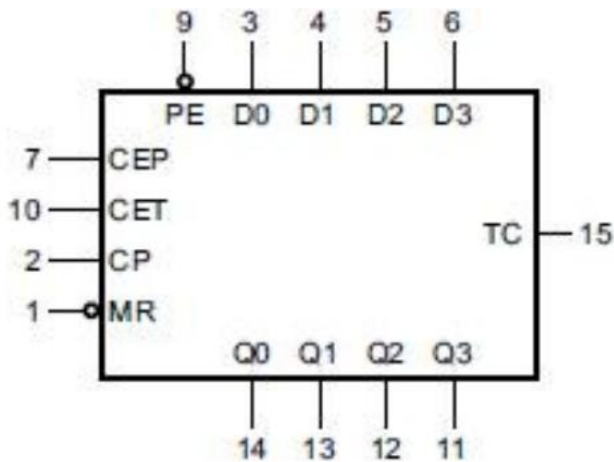

Figure 1. Logic symbol

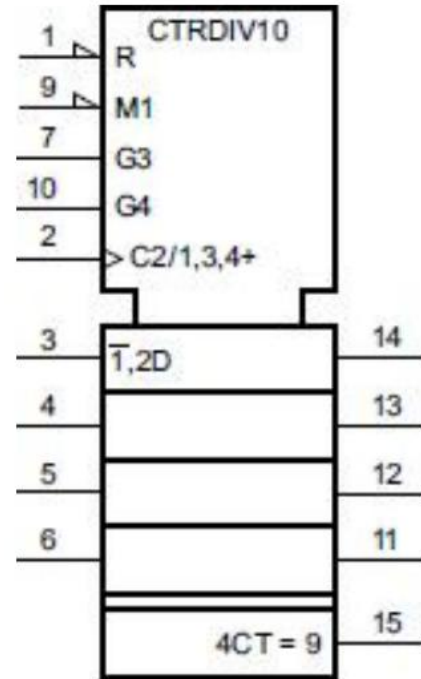

Figure 2. IEC Logic symbol

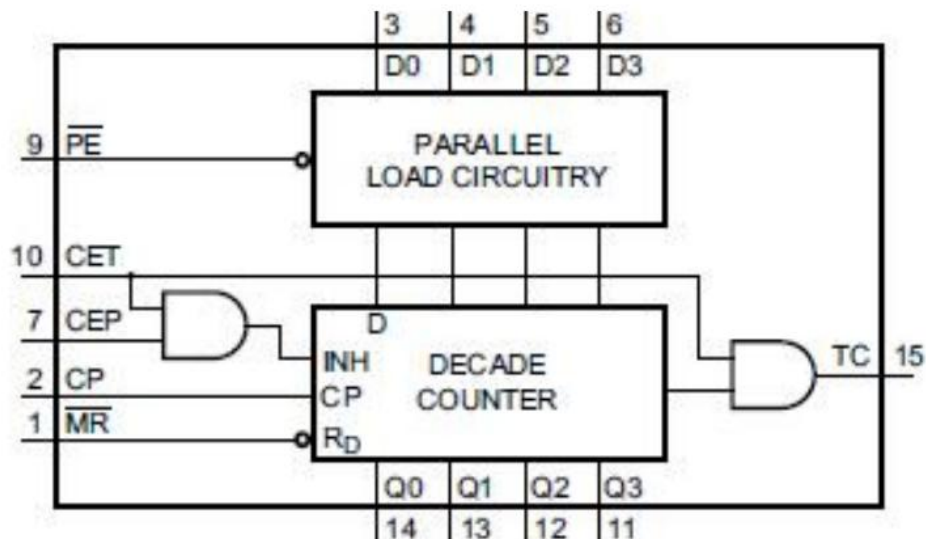

Figure 3. Functional diagram

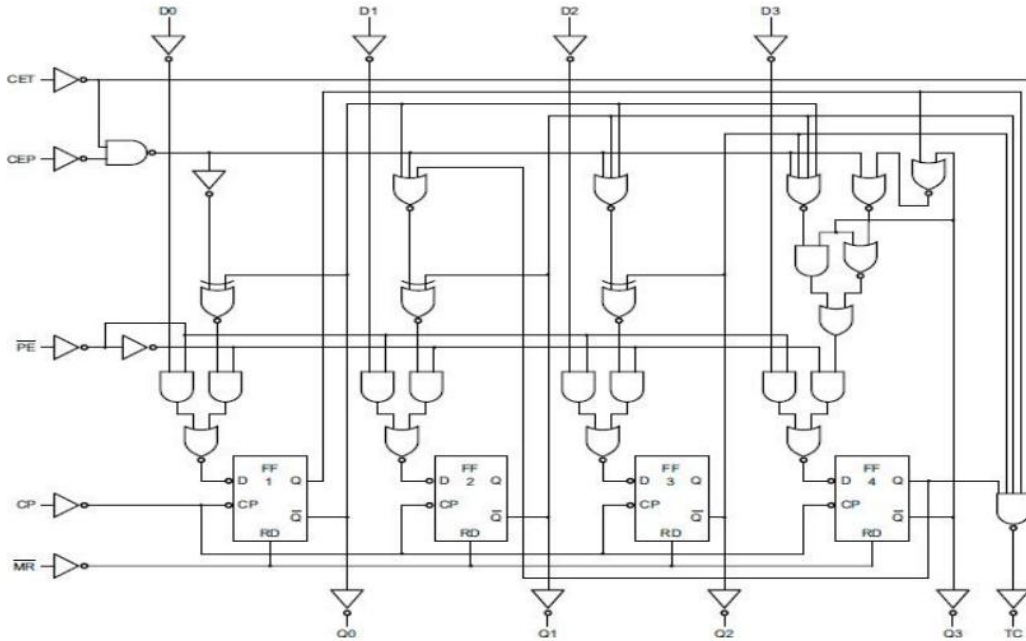

Figure 4. Logic diagram

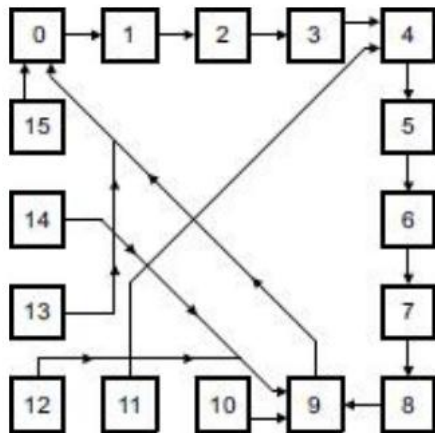

Figure 5. State diagram

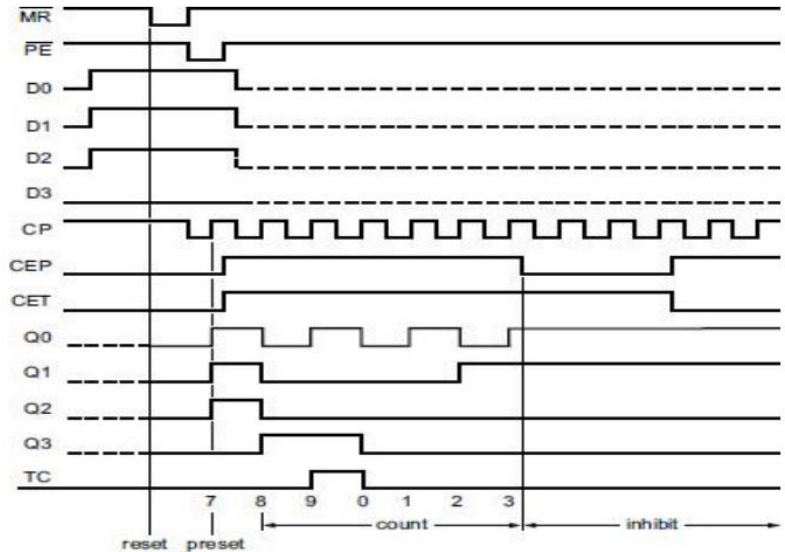
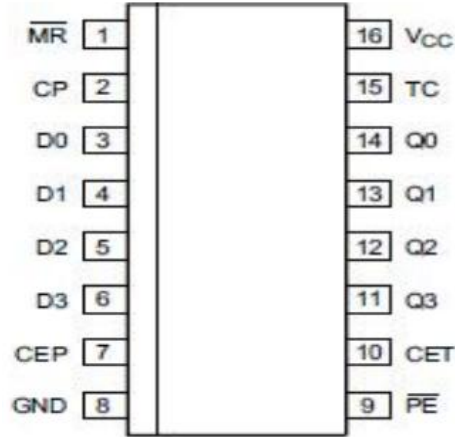

Figure 6. Typical timing sequence

Pin Configurations



Pin Description

Pin No.	Pin Name	Description
1	\overline{MR}	asynchronous master reset(active LOW)
2	CP	clock input(LOW-to-HIGH,edge triggered)
3	D0	data input
4	D1	data input
5	D2	data input
6	D3	data input
7	CEP	count enable input
8	GND	ground(0V)
9	\overline{PE}	parallel enable input(active LOW)
10	CET	count enable carry input
11	Q3	flip-flop output
12	Q2	flip-flop output
13	Q1	flip-flop output
14	Q0	flip-flop output
15	TC	terminal count output
16	Vcc	supply voltage

Function Table

Operating mode	Input						Output	
	\overline{MR}	CP	CEP	CET	\overline{PE}	Dn	Qn	TC
reset(clear)	L	X	X	X	X	X	L	L
parallel load	H	↑	X	X	l	l	L	L
	H	↑	X	X	l	h	H	[2]
count	H	↑	h	h	h	X	count	[2]
hold(do nothing)	H	X	l	X	h	X	q _n	[2]
	H	X	X	l	h	X	q _n	L

Note:

[1] H=HIGH voltage level; L=LOW voltage level; X=don't care; ↑=LOW-to-HIGH clock transition;

l=LOW voltage level one set-up time prior to the LOW-to-HIGH clock transition;

h=HIGH voltage level one set-up time prior to the LOW-to-HIGH CP transition;

q_n=lower case letters indicate the state of the referenced output one set-up time prior to the LOW-to-HIGH CP transition.

[2] The TC output is HIGH when CET is HIGH and the counter is at terminal count (HLLH).

Electrical Parameter

Absolute Maximum Ratings (Voltages are referenced to GND (ground=0V), unless otherwise specified.)

Parameter	Symbol	Conditions	Min.	Max.	Unit
supply voltage	V _{CC}	-	-0.5	+7.0	V
input clamping current	I _{IK}	V _I < -0.5V or V _I > V _{CC} +0.5V	-	±20	mA
output clamping current	I _{OK}	V _O < -0.5V or V _O > V _{CC} +0.5V	-	±20	mA
output current	I _O	-0.5V < V _O < V _{CC} +0.5V	-	±25	mA
supply current	I _{CC}	-	-	50	mA
ground current	I _{GND}	-	-50	-	mA
storage temperature	T _{stg}	-	-65	+150	°C
total power dissipation	P _{tot}	-	-	500	mW
soldering temperature	T _L	10s	DIP	245	°C
			SOP	250	

Note:

[1] For DIP16 packages: above 70°C the value of P_{tot} derates linearly with 12mW/K.

[2] For SOP16 packages: above 70°C the value of P_{tot} derates linearly with 8mW/K.

[3] For (T)SSOP16 packages: above 60°C the value of P_{tot} derates linearly with 5.5mW/K.

Recommended Operating Conditions

Parameter	Symbol	Conditions	Min.	Typ.	Max.	Unit
SN74HC160						
supply voltage	V _{CC}	-	2.0	5.0	6.0	V
input voltage	V _I	-	0	-	V _{CC}	V
output voltage	V _O	-	0	-	V _{CC}	V
input transition rise and fall rate	$\Delta t/\Delta V$	V _{CC} =2.0V	-	-	625	ns/V
		V _{CC} =4.5V	-	1.67	139	ns/V
		V _{CC} =6.0V	-	-	83	ns/V
ambient temperature	T _{amb}	-	-40	-	+105	°C
SN74HCT160						
supply voltage	V _{CC}	-	4.5	5.0	5.5	V
input voltage	V _I	-	0	-	V _{CC}	V
output voltage	V _O	-	0	-	V _{CC}	V
input transition rise and fall rate	$\Delta t/\Delta V$	V _{CC} =4.5V	-	1.67	139	ns/V
ambient temperature	T _{amb}	-	-40	-	+105	°C

Electrical Characteristics

DC Characteristics 1 (T_{amb}=25°C, voltages are referenced to GND (ground=0V), unless otherwise specified.)

Parameter	Symbol	Conditions	Min.	Typ.	Max.	Unit	
SN74HC160							
HIGH-level input voltage	V _{IH}	V _{CC} =2.0V	1.5	1.2	-	V	
		V _{CC} =4.5V	3.15	2.4	-	V	
		V _{CC} =6.0V	4.2	3.2	-	V	
LOW-level input voltage	V _{IL}	V _{CC} =2.0V	-	0.8	0.5	V	
		V _{CC} =4.5V	-	2.1	1.35	V	
		V _{CC} =6.0V	-	2.8	1.8	V	
HIGH-level output voltage	V _{OH}	V _I =V _{IH} or V _{IL}	I _O =-20uA; V _{CC} =2.0V	1.9	2.0	-	V
			I _O =-20uA; V _{CC} =4.5V	4.4	4.5	-	V
			I _O =-20uA; V _{CC} =6.0V	5.9	6.0	-	V
			I _O =-4.0mA; V _{CC} =4.5V	3.98	4.32	-	V
			I _O =-5.2mA; V _{CC} =6.0V	5.48	5.81	-	V
LOW-level output voltage	V _{OL}	V _I =V _{IH} or V _{IL}	I _O =20uA; V _{CC} =2.0V	-	0	0.1	V
			I _O =20uA; V _{CC} =4.5V	-	0	0.1	V
			I _O =20uA; V _{CC} =6.0V	-	0	0.1	V
			I _O =4.0mA; V _{CC} =4.5V	-	0.15	0.26	V

			$I_o=5.2mA;V_{CC}=6.0V$	-	0.16	0.26	V
input leakage current	I_i	$V_i=V_{CC}$ or GND; $V_{CC}=6.0V$		-	-	± 0.1	μA
supply current	I_{CC}	$V_i=V_{CC}$ or GND; $I_o=0A;V_{CC}=6.0V$		-	-	8.0	μA
input apacitance	C_i			-	3.5	-	pF
SN74HCT160							
HIGH-level input voltage	V_{IH}	$V_{CC}=4.5V$ to 5.5V		2.0	1.6	-	V
LOW-level input voltage	V_{IL}	$V_{CC}=4.5V$ to 5.5V		-	1.2	0.8	V
HIGH-level output voltage	V_{OH}	$V_i=V_{IH}$ or V_{IL} $V_{CC}=4.5V$	$I_o=-20\mu A$	4.4	4.5	-	V
			$I_o=-4.0\mu A$	3.98	4.32	-	V
LOW-level output voltage	V_{OL}	$V_i=V_{IH}$ or V_{IL} $V_{CC}=4.5V$	$I_o=20\mu A$	-	0	0.1	V
			$I_o=4.0\mu A$	-	0.15	0.26	V
input leakage current	I_i	$V_i=V_{CC}$ or GND; $V_{CC}=5.5V$		-	-	± 0.1	μA
supply current	I_{CC}	$V_i=V_{CC}$ or GND; $I_o=0A;V_{CC}=5.5V$		-	-	8.0	μA
additional Supply current	ΔI_{CC}	$V_i=V_{CC}-2.1V$; other inputs at V_{CC} or GND; $I_o=0V$; $V_{CC}=4.5V$ to 5.5V	pin $M\bar{R}$	-	95	342	μA
			pin CP	-	110	396	μA
			pin CEP and Dn	-	25	90	μA
			pin CET	-	75	270	μA
			pin $P\bar{E}$	-	30	108	μA
input apacitance	C_i			-	3.5	-	pF

DC Characteristics 2

($T_{amb}=-40^{\circ}C$ to $+85^{\circ}C$, voltages are referenced to GND (ground=0V), unless otherwise specified.)

Parameter	Symbol	Conditions	Min.	Typ.	Max.	Unit	
SN74HC160							
HIGH-level input voltage	V_{IH}	$V_{CC}=2.0V$	1.5	-	-	V	
		$V_{CC}=4.5V$	3.15	-	-	V	
		$V_{CC}=6.0V$	4.2	-	-	V	
LOW-level input voltage	V_{IL}	$V_{CC}=2.0V$	-	-	0.5	V	
		$V_{CC}=4.5V$	-	-	1.35	V	
		$V_{CC}=6.0V$	-	-	1.8	V	
HIGH-level output voltage	V_{OH}	$V_i=V_{IH}$ or V_{IL}	$I_o=-20\mu A;V_{CC}=2.0V$	1.9	-	-	V
			$I_o=-20\mu A;V_{CC}=4.5V$	4.4	-	-	V
			$I_o=-20\mu A;V_{CC}=6.0V$	5.9	-	-	V
			$I_o=-4.0mA;V_{CC}=4.5V$	3.84	-	-	V
			$I_o=-5.2mA;V_{CC}=6.0V$	5.34	-	-	V
LOW-level	V_{OL}	$V_i=V_{IH}$ or V_{IL}	$I_o=20\mu A;V_{CC}=2.0V$	-	-	0.1	V

output voltage			$I_O=20\mu A; V_{CC}=4.5V$	-	-	0.1	V
			$I_O=20\mu A; V_{CC}=6.0V$	-	-	0.1	V
			$I_O=4.0mA; V_{CC}=4.5V$	-	-	0.33	V
			$I_O=5.2mA; V_{CC}=6.0V$	-	-	0.33	V
input leakage current	I_I	$V_I=V_{CC}$ or GND; $V_{CC}=6.0V$	-	-	± 1.0	μA	
supply current	I_{CC}	$V_I=V_{CC}$ or GND; $I_O=0A; V_{CC}=6.0V$	-	-	80	μA	
SN74HCT160							
HIGH-level input voltage	V_{IH}	$V_{CC}=4.5V$ to $5.5V$	2.0	-	-	V	
LOW-level input voltage	V_{IL}	$V_{CC}=4.5V$ to $5.5V$	-	-	0.8	V	
HIGH-level output voltage	V_{OH}	$V_I=V_{IH}$ or V_{IL} $V_{CC}=4.5V$	$I_O=-20\mu A$	4.4	-	-	V
			$I_O=-4.0\mu A$	3.84	-	-	V
LOW-level output voltage	V_{OL}	$V_I=V_{IH}$ or V_{IL} $V_{CC}=4.5V$	$I_O=20\mu A$	-	-	0.1	V
			$I_O=4.0\mu A$	-	-	0.33	V
input leakage current	I_I	$V_I=V_{CC}$ or GND; $V_{CC}=5.5V$	-	-	± 1.0	μA	
supply current	I_{CC}	$V_I=V_{CC}$ or GND; $I_O=0A; V_{CC}=5.5V$	-	-	80	μA	
additional Supply current	ΔI_{CC}	$V_I=V_{CC}-2.1V$; other inputs at V_{CC} or GND; $I_O=0V$; $V_{CC}=4.5V$ to $5.5V$	pin \overline{MR}	-	-	427.5	μA
			pin CP	-	-	495	μA
			pin CEP and Dn	-	-	112.5	μA
			pin CET	-	-	337.5	μA
			pin \overline{PE}	-	-	135	μA

DC Characteristics 3

($T_{amb}=-40^\circ C$ to $+105^\circ C$, voltages are referenced to GND (ground=0V), unless otherwise specified.)

Parameter	Symbol	Conditions	Min.	Typ.	Max.	Unit	
SN74HC160							
HIGH-level input voltage	V_{IH}	$V_{CC}=2.0V$	1.5	-	-	V	
		$V_{CC}=4.5V$	3.15	-	-	V	
		$V_{CC}=6.0V$	4.2	-	-	V	
LOW-level input voltage	V_{IL}	$V_{CC}=2.0V$	-	-	0.5	V	
		$V_{CC}=4.5V$	-	-	1.35	V	
		$V_{CC}=6.0V$	-	-	1.8	V	
HIGH-level output voltage	V_{OH}	$V_I=V_{IH}$ or V_{IL}	$I_O=-20\mu A; V_{CC}=2.0V$	1.9	-	-	V
			$I_O=-20\mu A; V_{CC}=4.5V$	4.4	-	-	V
			$I_O=-20\mu A; V_{CC}=6.0V$	5.9	-	-	V
			$I_O=-4.0mA; V_{CC}=4.5V$	3.7	-	-	V
			$I_O=-5.2mA; V_{CC}=6.0V$	5.2	-	-	V

LOW-level output voltage	V_{OL}	$V_I=V_{IH}$ or V_{IL}	$I_O=20\mu A; V_{CC}=2.0V$	-	-	0.1	V
			$I_O=20\mu A; V_{CC}=4.5V$	-	-	0.1	V
			$I_O=20\mu A; V_{CC}=6.0V$	-	-	0.1	V
			$I_O=4.0mA; V_{CC}=4.5V$	-	-	0.4	V
			$I_O=5.2mA; V_{CC}=6.0V$	-	-	0.4	V
input leakage current	I_I	$V_I=V_{CC}$ or GND; $V_{CC}=6.0V$		-	-	± 1.0	μA
supply current	I_{CC}	$V_I=V_{CC}$ or GND; $I_O=0A; V_{CC}=6.0V$		-	-	160	μA
SN74HCT160							
HIGH-level input voltage	V_{IH}	$V_{CC}=4.5V$ to $5.5V$		2.0	-	-	V
LOW-level input voltage	V_{IL}	$V_{CC}=4.5V$ to $5.5V$		-	-	0.8	V
HIGH-level output voltage	V_{OH}	$V_I=V_{IH}$ or V_{IL} $V_{CC}=4.5V$	$I_O=-20\mu A$	4.4	-	-	V
			$I_O=-4.0\mu A$	3.7	-	-	V
LOW-level output voltage	V_{OL}	$V_I=V_{IH}$ or V_{IL} $V_{CC}=4.5V$	$I_O=20\mu A$	-	-	0.1	V
			$I_O=4.0\mu A$	-	-	0.4	V
input leakage current	I_I	$V_I=V_{CC}$ or GND; $V_{CC}=5.5V$		-	-	± 1.0	μA
supply current	I_{CC}	$V_I=V_{CC}$ or GND; $I_O=0A; V_{CC}=5.5V$		-	-	160	μA
additional Supply current	ΔI_{CC}	$V_I=V_{CC}-2.1V$; other inputs at V_{CC} or GND; $I_O=0V$; $V_{CC}=4.5V$ to $5.5V$	pin $M\bar{R}$	-	-	465.5	μA
			pin CP	-	-	539	μA
			pin CEP and Dn	-	-	122.5	μA
			pin CET	-	-	367.5	μA
			pin $P\bar{E}$	-	-	147	μA

AC Characteristics 1 ($T_{amb}=25^\circ C$, GND =0V; $t_r=t_f=6ns$; $C_L=50pF$, unless otherwise specified.)

Parameter	Symbol	Conditions	Min.	Typ.	Max.	Unit	
SN74HC160							
Propagation delay	t_{pd}	CP to Qn; see Figure8 ^[1]	$V_{CC}=2.0V$	-	61	185	ns
			$V_{CC}=4.5V$	-	22	37	ns
			$V_{CC}=5.0V; C_L=15pF$	-	19	-	ns
			$V_{CC}=6.0V$	-	18	31	ns
		CP to TC; see Figure8	$V_{CC}=2.0V$	-	69	215	ns
			$V_{CC}=4.5V$	-	25	43	ns
			$V_{CC}=5.0V; C_L=15pF$	-	21	-	ns
			$V_{CC}=6.0V$	-	20	31	ns
		CET to TC; see Figure9	$V_{CC}=2.0V$	-	47	150	ns
			$V_{CC}=4.5V$	-	17	30	ns
			$V_{CC}=5.0V; C_L=15pF$	-	14	-	ns

			$V_{CC}=6.0V$	-	14	26	ns
High to LOW Propagation delay	t_{PHL}	$M\bar{R}$ to Qn; see Figure10	$V_{CC}=2.0V$	-	69	210	ns
			$V_{CC}=4.5V$	-	25	42	ns
			$V_{CC}=5.0V;CL=15pF$	-	21	-	ns
			$V_{CC}=6.0V$	-	20	36	ns
		$M\bar{R}$ to TC; see Figure10	$V_{CC}=2.0V$	-	69	220	ns
			$V_{CC}=4.5V$	-	25	44	ns
			$V_{CC}=5.0V;CL=15pF$	-	21	-	ns
			$V_{CC}=6.0V$	-	20	37	ns
transition time	t_t	see Figure8 and see Figure9 ^[2]	$V_{CC}=2.0V$	-	19	75	ns
			$V_{CC}=4.5V$	-	7	15	ns
			$V_{CC}=6.0V$	-	6	13	ns
pulse width	t_w	CP HIGH or LOW;see Figure8	$V_{CC}=2.0V$	80	22	-	ns
			$V_{CC}=4.5V$	16	8	-	ns
			$V_{CC}=6.0V$	14	3	-	ns
		$M\bar{R}$ LOW; see Figure10	$V_{CC}=2.0V$	80	28	-	ns
			$V_{CC}=4.5V$	16	10	-	ns
			$V_{CC}=6.0V$	14	8	-	ns
Recovery time	t_{rec}	$M\bar{R}$ to CP; see Figure10	$V_{CC}=2.0V$	100	30	-	ns
			$V_{CC}=4.5V$	20	11	-	ns
			$V_{CC}=6.0V$	17	9	-	ns
Set-up time	t_{su}	Dn to CP; see Figure11	$V_{CC}=2.0V$	80	22	-	ns
			$V_{CC}=4.5V$	16	8	-	ns
			$V_{CC}=6.0V$	14	6	-	ns
		$P\bar{E}$ to CP; see Figure11	$V_{CC}=2.0V$	135	41	-	ns
			$V_{CC}=4.5V$	27	15	-	ns
			$V_{CC}=6.0V$	23	12	-	ns
		CEP,CET to CP; see Figure12	$V_{CC}=2.0V$	200	63	-	ns
			$V_{CC}=4.5V$	40	23	-	ns
			$V_{CC}=6.0V$	34	18	-	ns
Hold time	t_h	Dn to CP; see Figure11	$V_{CC}=2.0V$	0	-17	-	ns
			$V_{CC}=4.5V$	0	-6	-	ns
			$V_{CC}=6.0V$	0	-5	-	ns
		$P\bar{E}$ to CP; see Figure11	$V_{CC}=2.0V$	0	-41	-	ns
			$V_{CC}=4.5V$	0	-15	-	ns
			$V_{CC}=6.0V$	0	-12	-	ns
		CEP,CET to CP; see Figure12	$V_{CC}=2.0V$	0	-58	-	ns
			$V_{CC}=4.5V$	0	-21	-	ns
			$V_{CC}=6.0V$	0	-17	-	ns
Maximum	f_{MAX}	CP;see Figure8	$V_{CC}=2.0V$	6	18	-	MHz

frequency			V _{CC} =4.5V	30	55	-	MHz
			V _{CC} =5.0V;C _L =15pF	-	61	-	MHz
			V _{CC} =6.0V	35	66	-	MHz
power dissipation capacitance	C _{PD}	f _i =1MHz;;V _I =GND to V _{CC} ^[3]	-	39	-	pF	
SN74HCT160							
Propagation delay	t _{pd}	CP to Qn; see Figure8 ^[1]	V _{CC} =4.5V	-	25	43	ns
			V _{CC} =5.0V;C _L =15pF	-	21	-	ns
		CP to TC; see Figure8	V _{CC} =4.5V	-	28	48	ns
			V _{CC} =5.0V;C _L =15pF	-	24	-	ns
		CET to TC; see Figure9	V _{CC} =4.5V	-	17	35	ns
V _{CC} =5.0V;C _L =15pF	-		14	-	ns		
HIGH to LOW propagation delay	t _{PHL}	M _R to Qn; see Figure10	V _{CC} =4.5V	-	27	50	ns
			V _{CC} =5.0V;C _L =15pF	-	23	-	ns
		M _R to TC; see Figure10	V _{CC} =4.5V	-	30	50	ns
			V _{CC} =5.0V;C _L =15pF	-	26	-	ns
transition time	t _t	V _{CC} =4.5V;see Figure8,9 ^[2]	-	7	15	ns	
pulse width	t _w	CP HIGH or LOW;V _{CC} =4.5V;see Figure8	16	8	-	ns	
		M _R LOW;V _{CC} =4.5V;see Figure10	20	11	-	ns	
Recovery time	t _{rec}	M _R CP;V _{CC} =4.5V;see Figure10	20	9	-	ns	
Set-up time	t _{su}	Dn to CP;V _{CC} =4.5V;see Figure11	18	10	-	ns	
		P _E to CP;V _{CC} =4.5V;see Figure11	30	18	-	ns	
		CEP,CET to CP;V _{CC} =4.5V;see Figure12	50	30	-	ns	
Hold time	t _h	Dn to CP;V _{CC} =4.5V;see Figure11	0	-8	-	ns	
		P _E to CP;V _{CC} =4.5V;see Figure11	0	-13	-	ns	
		CEP,CET to CP;V _{CC} =4.5V;see Figure12	0	-21	-	ns	
Maximum frequency	f _{MAX}	CP;see Figure8	V _{CC} =4.5V	16	-28	-	MHz
			V _{CC} =5.0V;C _L =15pF	-	31	-	MHz
power dissipation capacitance	C _{PD}	f _i =1MHz;;V _I =GND to V _{CC} -1.5V ^[3]	-	34	-	pF	

Note:

[1]t_{pd} is the same as t_{PLH} and t_{PHL}.

[2]t_t is the same as t_{THL} and t_{TLH}.

[3]C_{PD} is used to determine the dynamic power dissipation (P_D in uW).

$P_D = C_{PD} \times V_{CC}^2 \times f_i \times N + \sum (C_L \times V_{CC}^2 \times f_o)$ where:

f_i=input frequency in MHz;

f_o=output frequency in MHz;

C_L=output load capacitance in pF;

V_{CC} =supply voltage in V;

N=number of inputs switching;

$\Sigma(C_L \times V_{CC}^2 \times f)$ =sum of outputs.

AC Characteristics 2 (Tamb=-40°C to +85°C, $t_r=t_f=6ns$; $C_L=50pF$, unless otherwise specified.)

Parameter	Symbol	Conditions	Min.	Typ.	Max.	Unit	
SN74HC160							
Propagation delay	t_{pd}	CP to Qn; see Figure8 ^[1]	$V_{CC}=2.0V$	-	-	230	ns
			$V_{CC}=4.5V$	-	-	46	ns
			$V_{CC}=6.0V$	-	-	39	ns
		CP to TC; see Figure8	$V_{CC}=2.0V$	-	-	270	ns
			$V_{CC}=4.5V$	-	-	54	ns
			$V_{CC}=6.0V$	-	-	46	ns
		CET to TC; see Figure9	$V_{CC}=2.0V$	-	-	190	ns
			$V_{CC}=4.5V$	-	-	38	ns
			$V_{CC}=6.0V$	-	-	33	ns
High to LOW Propagation delay	t_{PHL}	\overline{MR} to Qn; see Figure10	$V_{CC}=2.0V$	-	-	265	ns
			$V_{CC}=4.5V$	-	-	53	ns
			$V_{CC}=6.0V$	-	-	45	ns
		\overline{MR} to TC; see Figure10	$V_{CC}=2.0V$	-	-	275	ns
			$V_{CC}=4.5V$	-	-	55	ns
			$V_{CC}=6.0V$	-	-	47	ns
transition time	t_t	see Figure8 and see Figure9 ^[2]	$V_{CC}=2.0V$	-	-	95	ns
			$V_{CC}=4.5V$	-	-	19	ns
			$V_{CC}=6.0V$	-	-	16	ns
pulse width	t_w	CP HIGH or LOW; see Figure8	$V_{CC}=2.0V$	100	-	-	ns
			$V_{CC}=4.5V$	20	-	-	ns
			$V_{CC}=6.0V$	17	-	-	ns
		\overline{MR} LOW; see Figure10	$V_{CC}=2.0V$	100	-	-	ns
			$V_{CC}=4.5V$	20	-	-	ns
			$V_{CC}=6.0V$	17	-	-	ns
Recovery time	t_{rec}	\overline{MR} to CP; see Figure10	$V_{CC}=2.0V$	125	-	-	ns
			$V_{CC}=4.5V$	25	-	-	ns
			$V_{CC}=6.0V$	21	-	-	ns
Set-up time	t_{su}	Dn to CP; see Figure11	$V_{CC}=2.0V$	100	-	-	ns
			$V_{CC}=4.5V$	20	-	-	ns
			$V_{CC}=6.0V$	17	-	-	ns
		\overline{PE} to CP; see Figure11	$V_{CC}=2.0V$	170	-	-	ns
			$V_{CC}=4.5V$	34	-	-	ns
			$V_{CC}=6.0V$	29	-	-	ns



		CEP,CET to CP; see Figure12	V _{CC} =2.0V	250	-	-	ns
			V _{CC} =4.5V	50	-	-	ns
			V _{CC} =6.0V	43	-	-	ns
Hold time	t _h	Dn to CP; see Figure11	V _{CC} =2.0V	0	-	-	ns
			V _{CC} =4.5V	0	-	-	ns
			V _{CC} =6.0V	0	-	-	ns
		P \bar{E} to CP; see Figure11	V _{CC} =2.0V	0	-	-	ns
			V _{CC} =4.5V	0	-	-	ns
			V _{CC} =6.0V	0	-	-	ns
		CEP,CET to CP; see Figure12	V _{CC} =2.0V	0	-	-	ns
			V _{CC} =4.5V	0	-	-	ns
			V _{CC} =6.0V	0	-	-	ns
Maximum frequency	f _{MAX}	CP;see Figure8	V _{CC} =2.0V	4.8	-	-	MHz
			V _{CC} =4.5V	24	-	-	MHz
			V _{CC} =6.0V	28	-	-	MHz
SN74HCT160							
Propagation delay	t _{pd}	CP to Qn; see Figure8 ^[1]	V _{CC} =4.5V	-	-	54	ns
		CP to TC; see Figure8	V _{CC} =4.5V	-	-	60	ns
		CET to TC; see Figure9	V _{CC} =4.5V	-	-	44	ns
High to LOW propagation delay	t _{PHL}	M \bar{R} to Qn; see Figure10	V _{CC} =4.5V	-	-	63	ns
		M \bar{R} to TC; see Figure10	V _{CC} =4.5V	-	-	63	ns
transition time	t _t	V _{CC} =4.5V;see Figure8,9 ^[2]		-	-	19	ns
pulse width	t _w	CP HIGH or LOW;V _{CC} =4.5V;see Figure8		20	-	-	ns
		M \bar{R} LOW;V _{CC} =4.5V;see Figure10		25	-	-	ns
Recovery time	t _{rec}	M \bar{R} to CP;V _{CC} =4.5V;see Figure10		25	-	-	ns
Set-up time	t _{su}	Dn to CP;V _{CC} =4.5V;see Figure11		25	-	-	ns
		P \bar{E} to CP;V _{CC} =4.5V;see Figure11		44	-	-	ns
		CEP,CET to CP;V _{CC} =4.5V;see Figure12		63	-	-	ns
Hold time	t _h	Dn to CP;V _{CC} =4.5V;see Figure11		0	-	-	ns
		P \bar{E} to CP;V _{CC} =4.5V;see Figure11		0	-	-	ns
		CEP,CET to CP;V _{CC} =4.5V;see Figure12		0	-	-	ns
Maximum frequency	f _{MAX}	CP;see Figure8	V _{CC} =4.5V	13	-	-	MHz

Note:

[1] t_{pd} is the same as t_{PLH} and t_{PHL}.

[2] t_t is the same as t_{THL} and t_{TLH}.

AC Characteristics 3 (Tamb=-40°C to +105°C; GND=0V; tr=tf=6ns; CL=50pF, unless otherwise specified.)

Parameter	Symbol	Conditions	Min.	Typ.	Max.	Unit	
SN74HC160							
Propagation delay	t _{pd}	CP to Qn; see Figure8 ^[1]	V _{CC} =2.0V	-	-	280	ns
			V _{CC} =4.5V	-	-	56	ns
			V _{CC} =6.0V	-	-	48	ns
		CP to TC; see Figure8	V _{CC} =2.0V	-	-	325	ns
			V _{CC} =4.5V	-	-	65	ns
			V _{CC} =6.0V	-	-	55	ns
		CET to TC; see Figure9	V _{CC} =2.0V	-	-	225	ns
			V _{CC} =4.5V	-	-	45	ns
			V _{CC} =6.0V	-	-	38	ns
High to LOW Propagation delay	t _{PHL}	M \bar{R} to Qn; see Figure10	V _{CC} =2.0V	-	-	315	ns
			V _{CC} =4.5V	-	-	63	ns
			V _{CC} =6.0V	-	-	54	ns
		M \bar{R} to TC; see Figure10	V _{CC} =2.0V	-	-	330	ns
			V _{CC} =4.5V	-	-	66	ns
			V _{CC} =6.0V	-	-	56	ns
transition time	t _t	see Figure8 and see Figure9 ^[2]	V _{CC} =2.0V	-	-	110	ns
			V _{CC} =4.5V	-	-	22	ns
			V _{CC} =6.0V	-	-	19	ns
pulse width	t _w	CP HIGH or LOW;see Figure8	V _{CC} =2.0V	120	-	-	ns
			V _{CC} =4.5V	24	-	-	ns
			V _{CC} =6.0V	20	-	-	ns
		M \bar{R} LOW; see Figure10	V _{CC} =2.0V	120	-	-	ns
			V _{CC} =4.5V	24	-	-	ns
			V _{CC} =6.0V	20	-	-	ns
Recovery time	t _{rec}	M \bar{R} to CP; see Figure10	V _{CC} =2.0V	150	-	-	ns
			V _{CC} =4.5V	30	-	-	ns
			V _{CC} =6.0V	26	-	-	ns
Set-up time	t _{su}	Dn to CP; see Figure11	V _{CC} =2.0V	120	-	-	ns
			V _{CC} =4.5V	24	-	-	ns
			V _{CC} =6.0V	20	-	-	ns
		P \bar{E} to CP; see Figure11	V _{CC} =2.0V	205	-	-	ns
			V _{CC} =4.5V	41	-	-	ns
			V _{CC} =6.0V	35	-	-	ns

		CEP,CET to CP; see Figure12	V _{CC} =2.0V	300	-	-	ns
			V _{CC} =4.5V	60	-	-	ns
			V _{CC} =6.0V	51	-	-	ns
Hold time	t _h	Dn to CP; see Figure11	V _{CC} =2.0V	0	-	-	ns
			V _{CC} =4.5V	0	-	-	ns
			V _{CC} =6.0V	0	-	-	ns
		P \bar{E} to CP; see Figure11	V _{CC} =2.0V	0	-	-	ns
			V _{CC} =4.5V	0	-	-	ns
			V _{CC} =6.0V	0	-	-	ns
		CEP,CET to CP; see Figure12	V _{CC} =2.0V	0	-	-	ns
			V _{CC} =4.5V	0	-	-	ns
			V _{CC} =6.0V	0	-	-	ns
Maximum frequency	f _{MAX}	CP;see Figure8	V _{CC} =2.0V	4.0	-	-	MHz
			V _{CC} =4.5V	20	-	-	MHz
			V _{CC} =6.0V	24	-	-	MHz
SN74HCT160							
Propagation delay	t _{pd}	CP to Qn; see Figure8 ^[1]	V _{CC} =4.5V	-	-	65	ns
		CP to TC; see Figure8	V _{CC} =4.5V	-	-	72	ns
		CET to TC; see Figure9	V _{CC} =4.5V	-	-	53	ns
High to LOW propagation delay	t _{PHL}	M \bar{R} to Qn; see Figure10	V _{CC} =4.5V	-	-	15	ns
		M \bar{R} to TC; see Figure10	V _{CC} =4.5V	-	-	75	ns
transition time	t _t	V _{CC} =4.5V;see Figure8,9 ^[2]		-	-	22	ns
pulse width	t _w	CP HIGH or LOW;V _{CC} =4.5V;see Figure8		24	-	-	ns
		M \bar{R} LOW;V _{CC} =4.5V;see Figure10		30	-	-	ns
Recovery time	t _{rec}	M \bar{R} to CP;V _{CC} =4.5V;see Figure10		30	-	-	ns
Set-up time	t _{su}	Dn to CP;V _{CC} =4.5V;see Figure11		30	-	-	ns
		P \bar{E} to CP;V _{CC} =4.5V;see Figure11		53	-	-	ns
		CEP,CET to CP;V _{CC} =4.5V;see Figure12		75	-	-	ns
Hold time	t _h	Dn to CP;V _{CC} =4.5V;see Figure11		0	-	-	ns
		P \bar{E} to CP;V _{CC} =4.5V;see Figure11		0	-	-	ns
		CEP,CET to CP;V _{CC} =4.5V;see Figure12		0	-	-	ns
Maximum frequency	f _{MAX}	CP;see Figure8	V _{CC} =4.5V	11	-	-	MHz

Note:

[1] t_{pd} is the same as t_{PLH} and t_{PHL}.

[2] t_t is the same as t_{THL} and t_{TLH}.

Testing Circuit

AC Testing Circuit

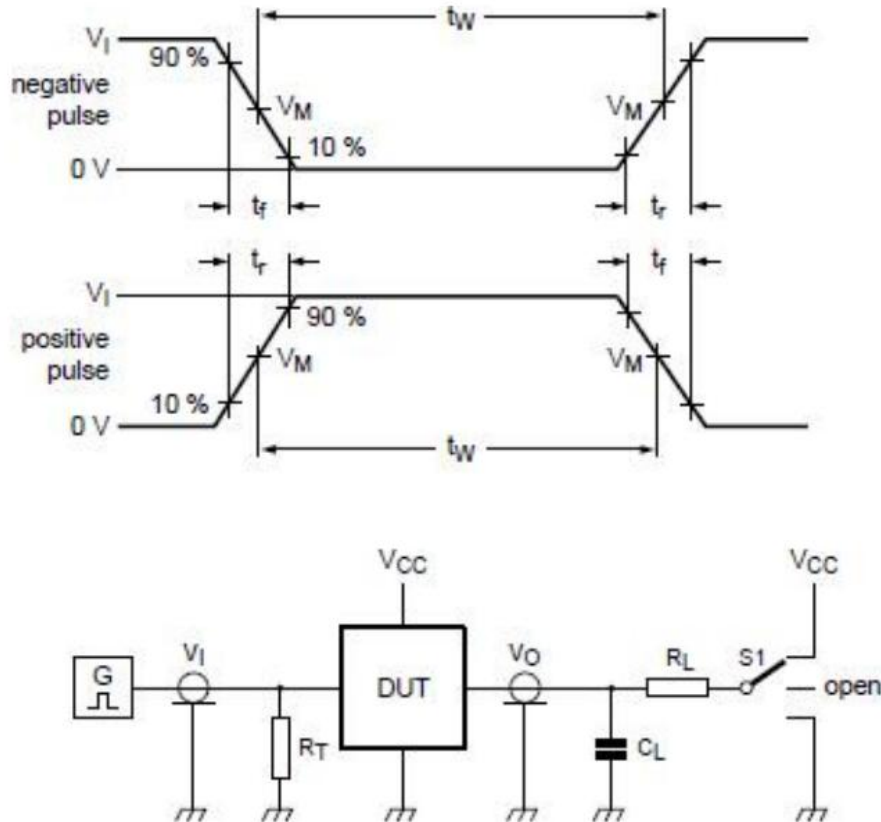

Figure 7. Test circuit for measuring switching times

Definitions for test circuit:

C_L =Load capacitance including jig and probe capacitance.

R_T =Termination resistance should be equal to the output impedance Z_o of the pulse generator.

R_L =Load resistance

S1=Test selection switch

AC Testing Waveforms

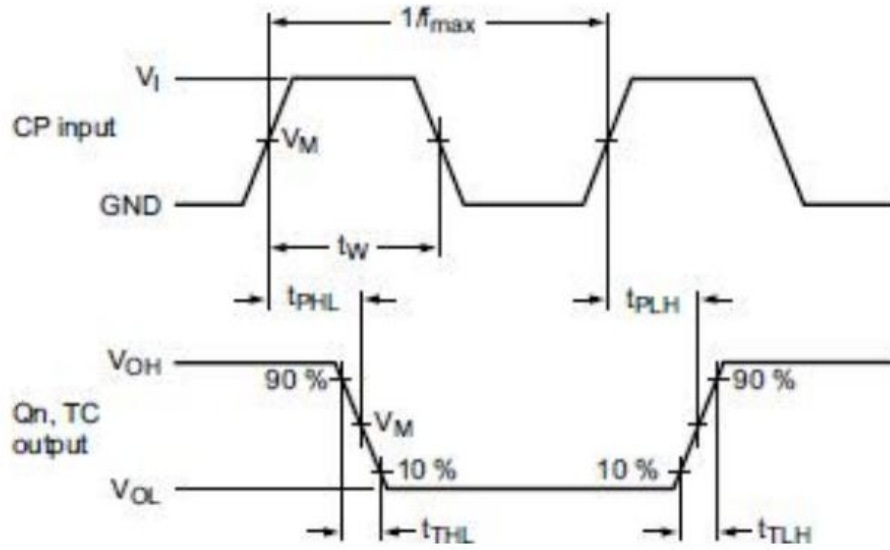

Figure 8. The clock (CP) to outputs (Qn, TC) propagation delays, pulse width, output transition times and maximum frequency

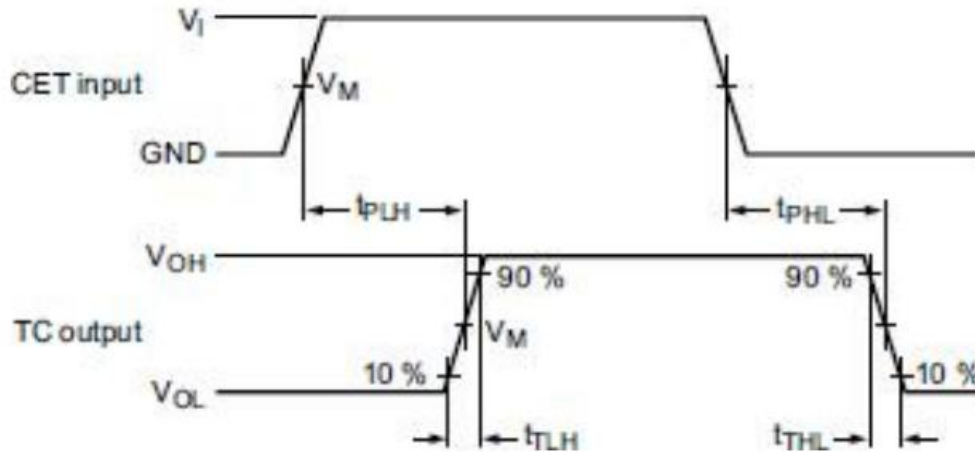

Figure 9. The count enable carry input (CET) to terminal count output (TC) propagation delays and output transition times

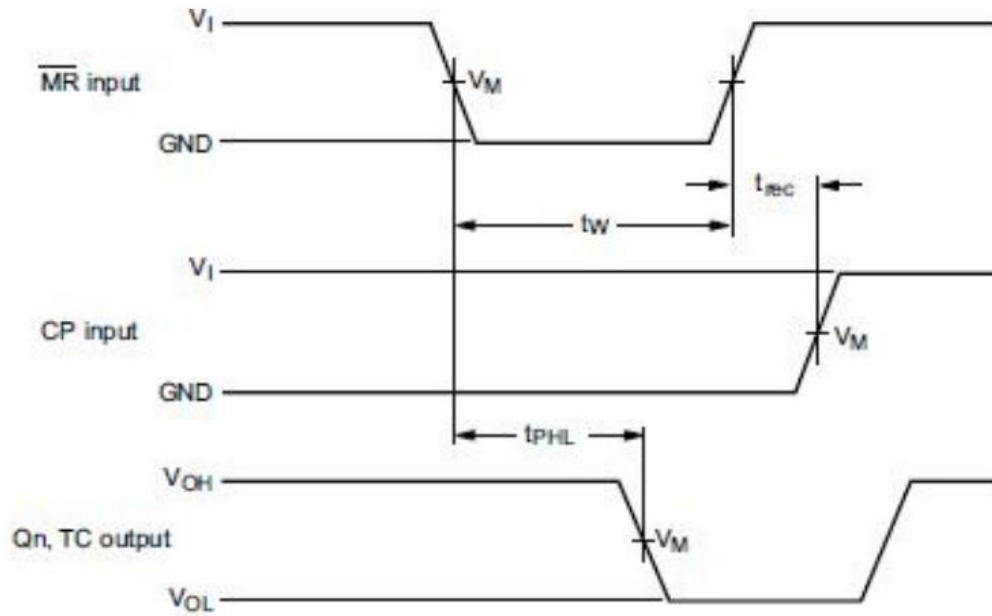

Figure 10. The master reset (\overline{MR}) pulse width, master reset to output (Qn, TC) propagation delays, and the master reset to clock (CP) recovery times

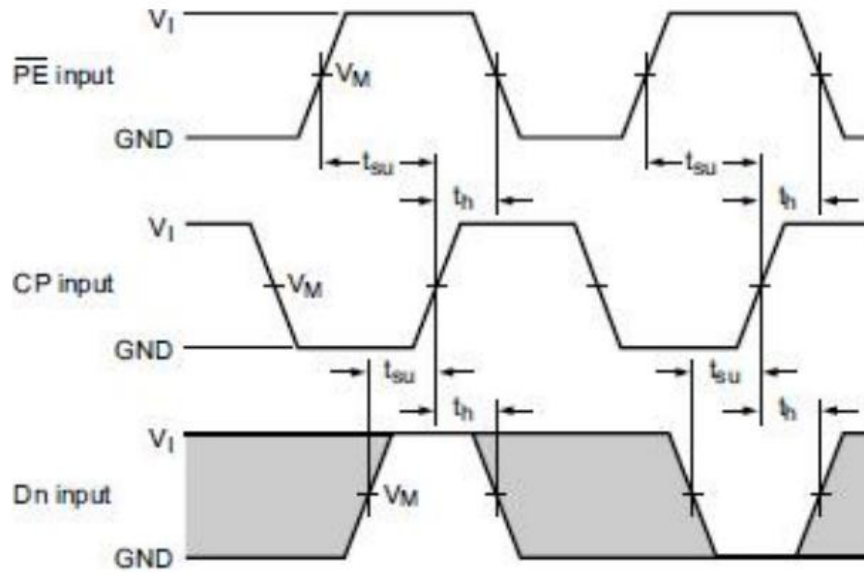

Figure 11. The data input (Dn) and parallel enable input (\overline{PE}) set-up and hold times

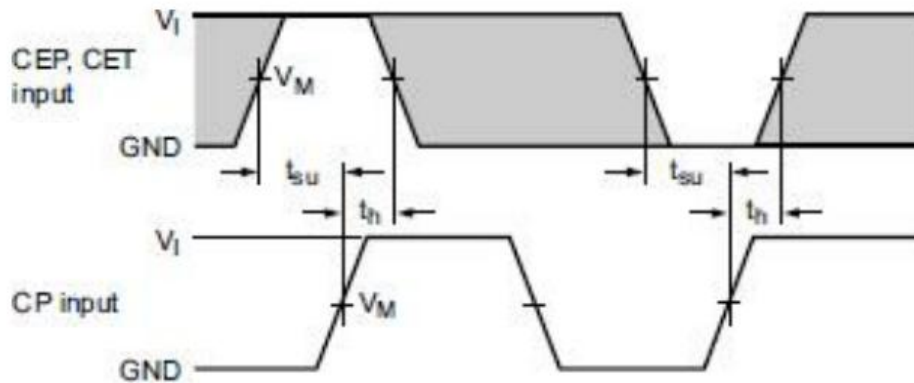

Figure 12. The count enable input (CEP) and count enable carry input (CET) set-up and hold times

Measurement Points

Type	Input		Output
	V_I	V_M	V_M
SN74HC160	GND to V_{CC}	$0.5 \times V_{CC}$	$0.5 \times V_{CC}$
SN74HCT160	GND to 3V	1.3V	1.3V

Test Data

Type	Input	Load	S1 position
------	-------	------	-------------



	V _I	t _r ,t _f	C _L	R _L	t _{PHL} ,t _{PLH}
SN74HC160	V _{CC}	6.0ns	15pF,50pF	1KΩ	open
SN74HCT160	3.0V	6.0ns	15pF,50pF	1KΩ	open

Package Information

DIP16

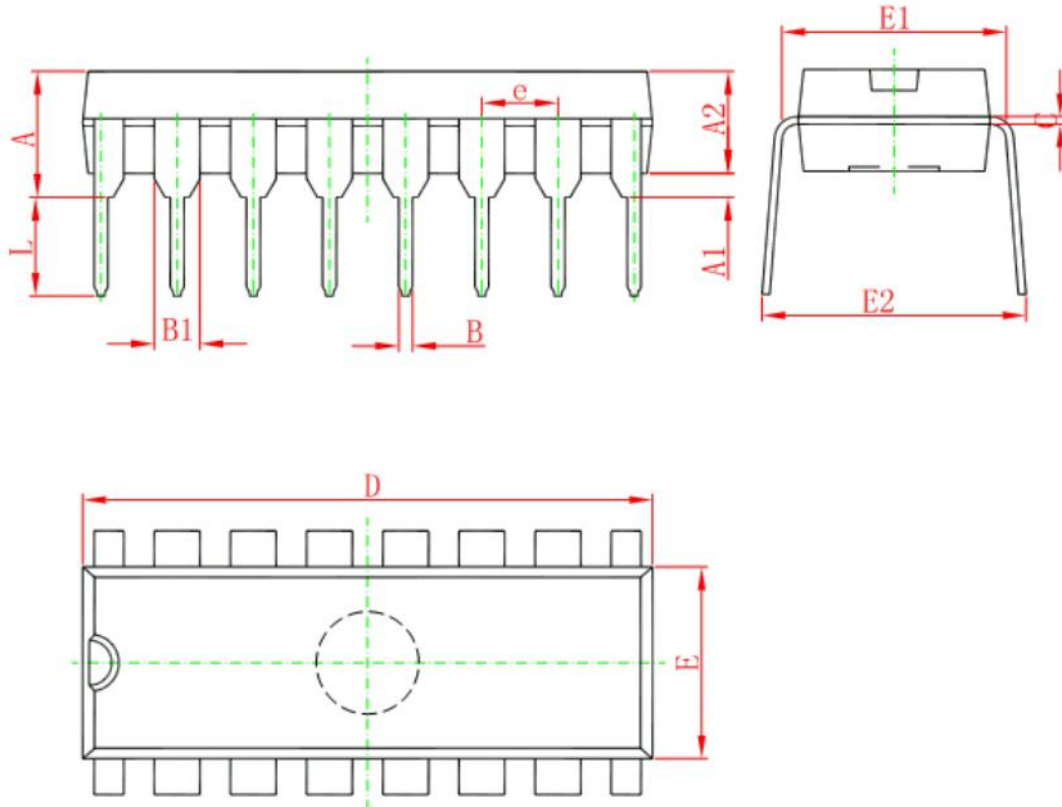

Symbol	Dimensions In Millimeters		Dimensions In Inches	
	Min	Max	Min	Max
A	3.710	4.310	0.146	0.170
A1	0.510		0.020	
A2	3.200	3.600	0.126	0.142
B	0.380	0.570	0.015	0.022
B1	1.524(BSC)		0.060(BSC)	
C	0.204	0.360	0.008	0.014
D	18.800	19.200	0.740	0.756
E	6.200	6.600	0.244	0.260
E1	7.320	7.920	0.288	0.312
e	2.540(BSC)		0.100(BSC)	
L	3.000	3.600	0.118	0.142
E2	8.400	9.000	0.331	0.354

SOP16

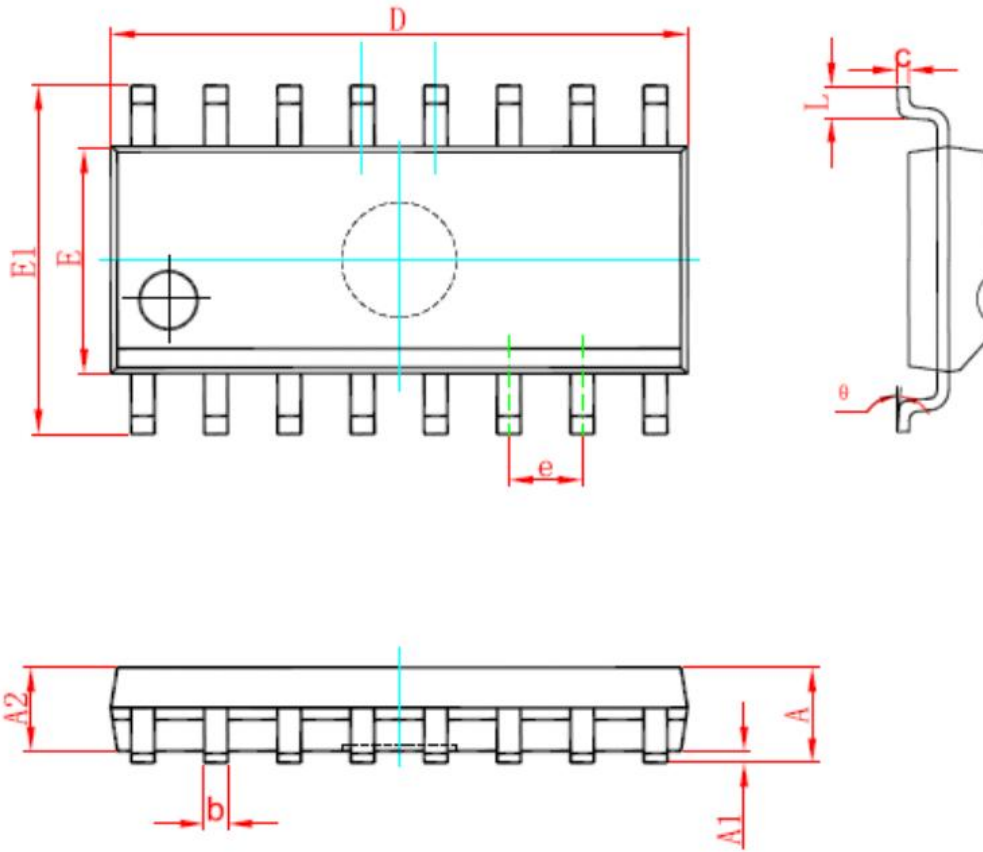

Symbol	Dimensions In Millimeters		Dimensions In Inches	
	Min	Max	Min	Max
A	1.350	1.750	0.053	0.069
A1	0.100	0.250	0.004	0.010
A2	1.350	1.550	0.053	0.061
b	0.330	0.510	0.013	0.020
C	0.170	0.250	0.007	0.010
D	9.800	10.200	0.386	0.402
E	3.800	4.000	0.150	0.157
E1	5.800	6.200	0.228	0.244
e	1.270(BSC)		0.050(BSC)	
L	0.400	1.270	0.016	0.050
θ	0°	8°	0°	8°

TSSOP16

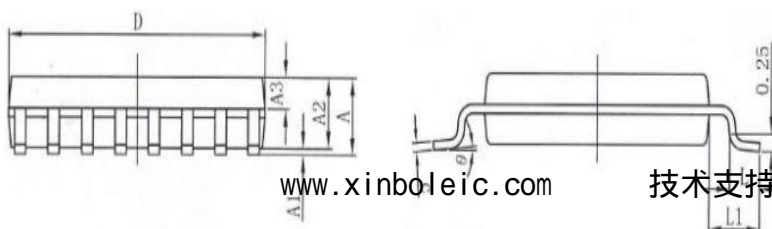

以试为准



SYMBOL	MILLIMETER		
	MIN	NOM	MAX
A	-	-	1.20
A1	0.05	-	0.15
A2	0.90	1.00	1.05
A3	0.39	0.44	0.49
b	0.20	-	0.28
b1	0.19	0.22	0.25
c	0.13	-	0.17
cl	0.12	0.13	0.14
D	4.90	5.00	5.10
E	6.20	6.40	6.60
E1	4.30	4.40	4.50
e	0.65BSC		
L	0.45	0.60	0.75
L1	1.00BSC		
θ	0	-	8°

Statements And Notes

Part name	Hazardous substances or Elements									
	Lead and lead compounds	Mercury and mercury compounds	Cadmium and cadmium compounds	Hexavalent chromium compounds	Polybrominated biphenyls	Polybrominated biphenyl ethers	Dibutyl phthalate	Butyl benzyl phthalate	Di-2-ethylhexyl phthalate	Diisobutyl phthalate
Lead frame	○	○	○	○	○	○	○	○	○	○
Plastic resin	○	○	○	○	○	○	○	○	○	○
Chip	○	○	○	○	○	○	○	○	○	○
The lead	○	○	○	○	○	○	○	○	○	○
Plastic sheet installed	○	○	○	○	○	○	○	○	○	○
explanation	○: Indicates that the content of hazardous substances or elements in the detection limit of the following the SJ/T11363-2006 standard. ×: Indicates that the content of hazardous substances or elements exceeding the SJ/T11363-2006 Standard limit requirements									

Statement:



- ◇ Shenzhen xinbole electronics co., ltd. reserves the right to change the product specifications, without notice!
Before placing an order, the customer needs to confirm whether the information obtained is the latest version, and verify the integrity of the relevant information.
- ◇ Any semiconductor product is liable to fail or malfunction under certain conditions, and the buyer shall be responsible for complying with safety standards in the system design and whole machine manufacturing using Shenzhen xinbole electronics co., ltd products, and take appropriate security measures to avoid the potential risk of failure may result in personal injury or property losses of the situation occurred!
- ◇ Product performance is never ending, Shenzhen xinbole electronics co., ltd will be dedicated to provide customers with better performance, better quality of integrated circuit products.

X-ON Electronics

Largest Supplier of Electrical and Electronic Components

Click to view similar products for [Counter ICs](#) category:

Click to view products by [XBLW](#) manufacturer:

Other Similar products are found below :

[CD4018BE](#) [CD4033BE](#) [CD4060BE](#) [CD4040BE](#) [NLV14040BDR2G](#) [RFDIP1607ALM9T21](#) [RFDIP1606L708D1T](#) [RFTIP2510T12A8Q1C](#)
[74HC161DT](#) [CD4028BM/TR](#) [CD4060DM/TR](#) [CD4022BE](#) [CD4060DMT/TR](#) [CD4060BMT/TR](#) [74HC192M/TR](#) [CD4020BMT/TR](#)
[74HC193M/TR](#) [CD4518BM/TR](#) [CD4060TA16.TB](#) [CD4060DE](#) [CD4017CN](#) [CD4017SA.TB](#) [CD4022BM/TR](#) [CD4022BMT/TR](#)
[CD4028BDRG](#) [CD4060BDRG](#) [CD4017DA.TB](#) [CD4520BDRG](#) [CD4520BM\(LX\)](#) [CD4518BM\(LX\)](#) [SN74HC393DR\(LX\)](#) [CD4060BM\(LX\)](#)
[CD4060BE\(LX\)](#) [SN74HC192N\(XBLW\)](#) [CD4040BM\(LX\)](#) [CD4026BM\(LX\)](#) [CD40103BDR\(LX\)](#) [SN74LS192DR\(LX\)](#) [SN74HC161DR \(LX\)](#)
[CD40193BE\(LX\)](#) [CD4060BDTR\(XBLW\)](#) [SN74LS393DR](#) [SN74LS193N\(LX\)](#) [SN74LS193DR\(LX\)](#) [CD4017BM\(LX\)](#) [CD40193BM\(LX\)](#)
[SN74LS192N\(LX\)](#) [SN74LS160N\(LX\)](#) [SN74LS161N\(LX\)](#) [CD4024BM\(LX\)](#)