

General Description

The XBLW TDA2050 is a monolithic integrated circuit in Pentawatt package, intended for use as an audio class AB audio amplifier. Thanks to its high power capability the TDA2050 is able to provide up to 35W true rms power into 4 ohm load @ THD = 10%, $V_S = 18V$, $f = 1KHz$ and up to 32W into 8ohm load @ THD = 10%, $V_S = 22V$, $f = 1KHz$. Moreover, the TDA 2050 delivers typically 50W music power into 4 ohm load over 1 sec at $V_S = 22.5V$, $f = 1KHz$.

The high power and very low harmonic and cross- over distortion (THD = 0.05% typ, @ $V_S = 22V$, $P_O = 0.1$ to 15W, $R_L = 8ohm$, $f = 100Hz$ to 15KHz) make the device most suitable for both HiFi and high class TV sets.

General Description

- High Output Power(40W Music Power Iec 268.3 Rules)High Operating Supply Voltage (50V)
- Single Or Split Supply Operations
- Very Low Distortion
- Short Circuit Protection (Out To Gnd)
- Thermal Shutdown

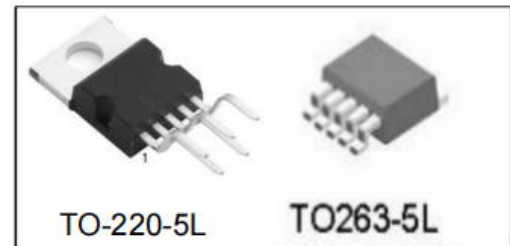

Ordering Information

Product Model	Package Type	Marking	Packing	Packing Qty
XBLW TDA2050A	TO-220-5L	TDA2050A	Tube	1000/Box
XBLW TDA2050ADTR	TO-263-5L	TDA2050A	Tape	500/Reel

PIN CONNECTION (Top view)

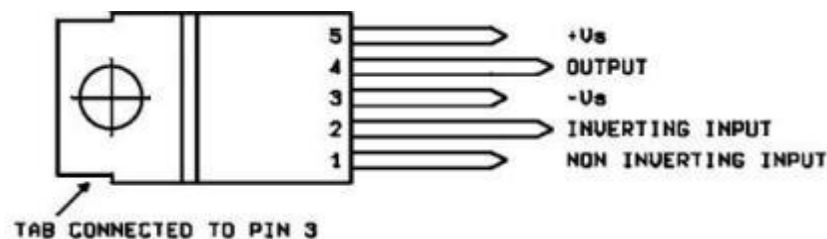

SCHEMATIC DIAGRAM

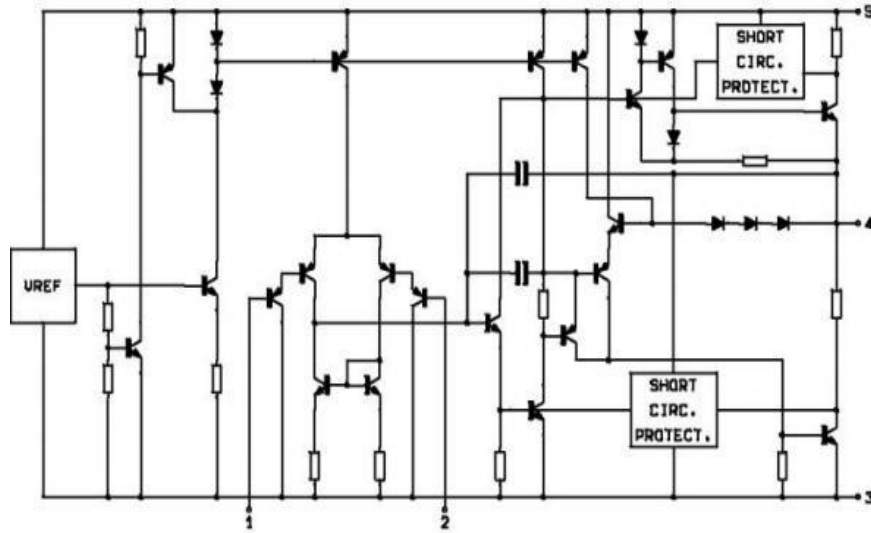

TEST AND APPLICATION CIRCUIT

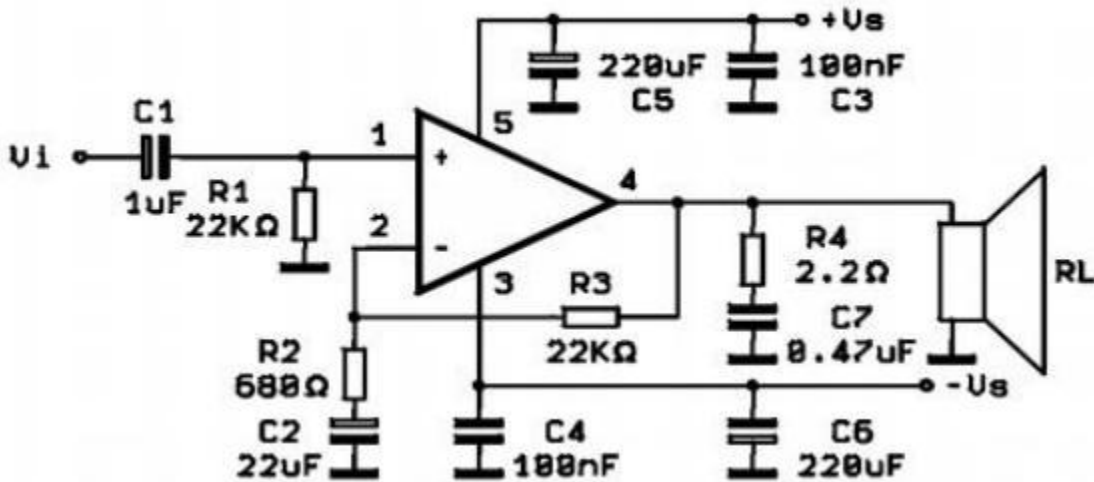

ABSOLUTE MAXIMUM RATINGS

Symbol	Parameter	Value	Unit
VS	Supply Voltage	±25	V
Vi	Input Voltage	VS	
Vi	Differential Input Voltage	±15	V
IO	Output Peak Current (internally limited)	5	A
Ptot	Power Dissipation TCASE = 75. C	25	W
Tstg, Tj	Storage and Junction Temperature	-40 to 150	. C
T _L	Lead Temperature (Soldering, 10 seconds)	245	. C

THERMAL DATA

Symbol	Description	Value	Unit
Rth j-case	Thermal Resistance junction-case	Max 3	. CW

ELECTRICAL CHARACTERISTICS

(Refer to the Test Circuit, $V_S = \pm 18V$, $T_{amb} = 25.0^\circ C$, $f = 1\text{ kHz}$; un-less otherwise specified)

Symbol	Parameter	Test Condition	Min.	Typ.	Max.	Unit	
VS	Supply Voltage Range		± 4.5		± 25	V	
Id	Quiescent Drain Current	$V_S = \pm 4.5V$		30	50	mA	
		$V_S = \pm 25V$		55	90	mA	
Ib	Input Bias Current	$V_S = \pm 22V$		0.1	0.5	μA	
VOS	Input Offset Voltage	$V_S = \pm 22V$			± 15	mV	
IOS	Input Offset Current	$V_S = \pm 22V$			± 200	nA	
PO	RMS Output Power	d = 0.5% $R_L = 4\Omega$ $R_L = 8\Omega$ $V_S = \pm 22V$ $R_L = 8\Omega$	24	28 18		W W W	
		d = 10% $R_L = 4\Omega$ $R_L = 8\Omega$ $V_S = \pm 22V$ $R_L = 8\Omega$		35 22 32		W W W	
		Music Power IEC268.3 RULES		50		W	
	d	Total Harmonic Distortion	$R_L = 4$ f = 1kHz, $P_o = 0.1$ to 24W f = 100Hz to 10kHz, $P_o = 0.1$ to 18W		0.03	0.5 0.5	% %
			$V_S = \pm 22V$ $R_L = 8$ f = 1kHz, $P_o = 0.1$ to 20W f = 100Hz to 10kHz, $P_o = 0.1$ to 15W		0.02	0.5	% %
SR	Slew Rate		5	8		V/ μs	
GV	Open Loop Voltage Gain			80		dB	
GV	Closed Loop Voltage Gain		30	30.5	31	dB	
BW	Power Bandwidth (-3dB)	$R_L = 4\Omega$ $V_i = 200mV$		20 to 80,000		Hz	
eN	Total Input Noise	curve A B = 22Hz to 22kHz		4		μV	
				5	10	μV	
Ri	Input Resistance (pin 1)		500			k Ω	
SVR	Supply Voltage Rejection	$R_s = 22k\Omega$; f = 100Hz; Vripple = 0.5Vrms		45		dB	
η	Efficiency	$P_o = 28W$; $R_L = 4\Omega$ $P_o = 25W$; $R_L = 8\Omega$; $V_S = \pm 22V$		65		%	
				67		%	
Tsd-j	Thermal Shut-down Junction Temperature			150		$^\circ C$	

Figure 1: Split Supply Typical Application Circuit

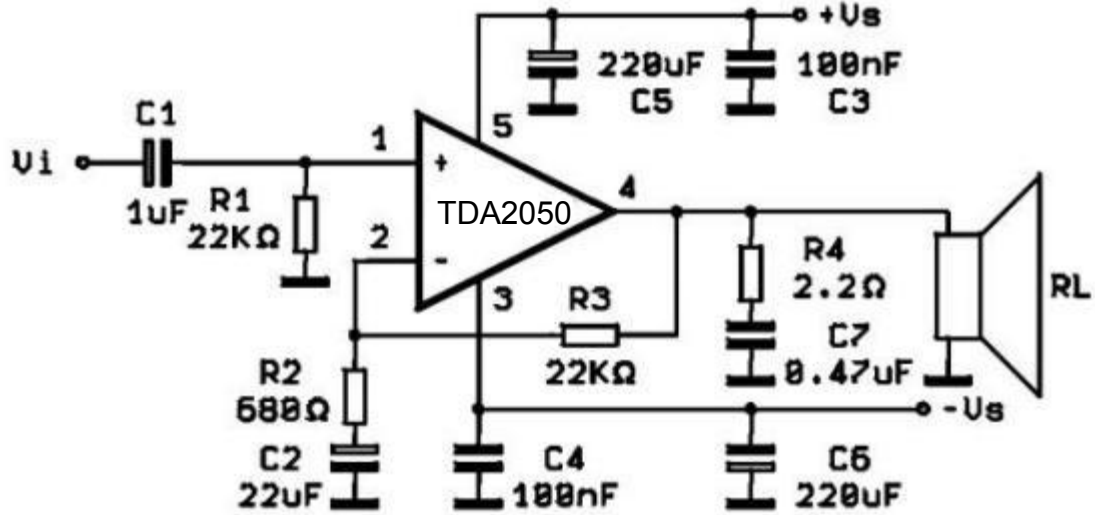
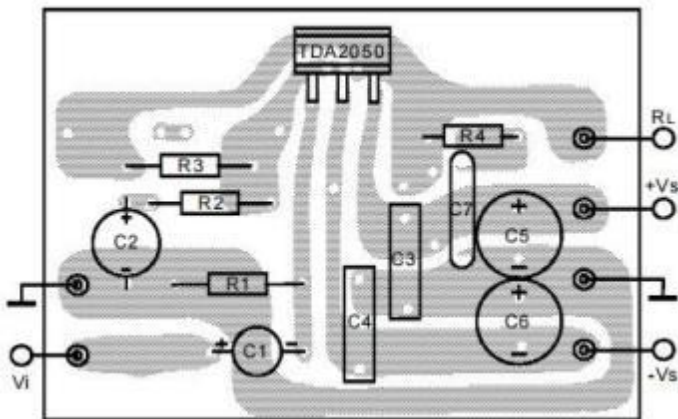

Figure 2: P.C. Board and Components Layout of the Circuit of Fig. 1 (1:1)



SPLIT SUPPLY APPLICATION SUGGESTIONS

The recommended values of the external components are those shown on the application circuit of fig. 2. Different values can be used. The following table can help the designer.

Component	Recommended Value	Purpose	Larger than Recommended Value	Smaller than Recommended Value
R1	22kΩ	Input Impedance	Increase of Input Impedance	Decrease of Input Impedance
R2	680	Feedback Resistor	Decrease of Gain (*)	Increase of Gain
R3	22k		Increase of Gain	Decrease of Gain (*)
R4	2.2	Frequency Stability	Danger of Oscillations	
C1	1μF	Input Decoupling DC		Higher Low-frequency cut-off
C2	22μF	Inverting Input DC Decoupling	Increase of Switch ON/OFF Noise	Higher Low-frequency cut-off
C3	100nF	Supply Voltage Bypass		Danger of Oscillations
C4				
C5	220μF	Supply Voltage Bypass		Danger of Oscillations
C6				
C7	0.47μF	Frequency Stability		Danger of Oscillations

(*) The gain must be higher than 24dB

PRINTED CIRCUIT BOARD

The layout shown in fig. 2 should be adopted by the designers. If different layouts are used, the ground points of input 1 and input 2 must be well decoupled from the ground return of the output in which a high current flows.

Figure 3: Single Supply Typical Application Circuit

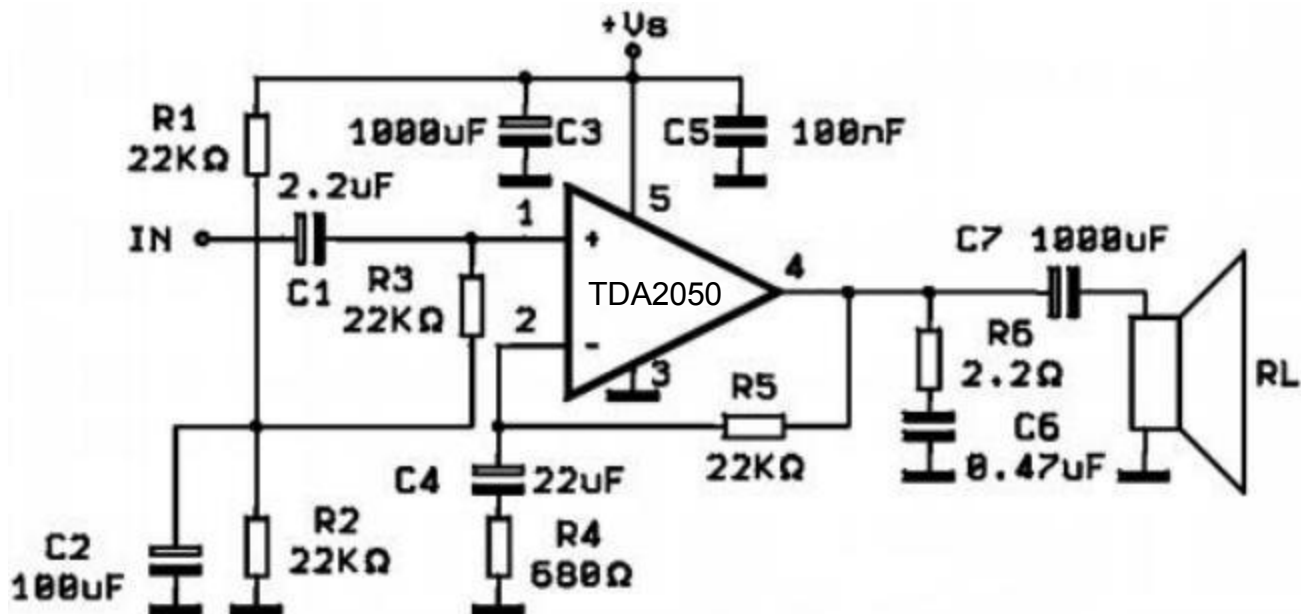
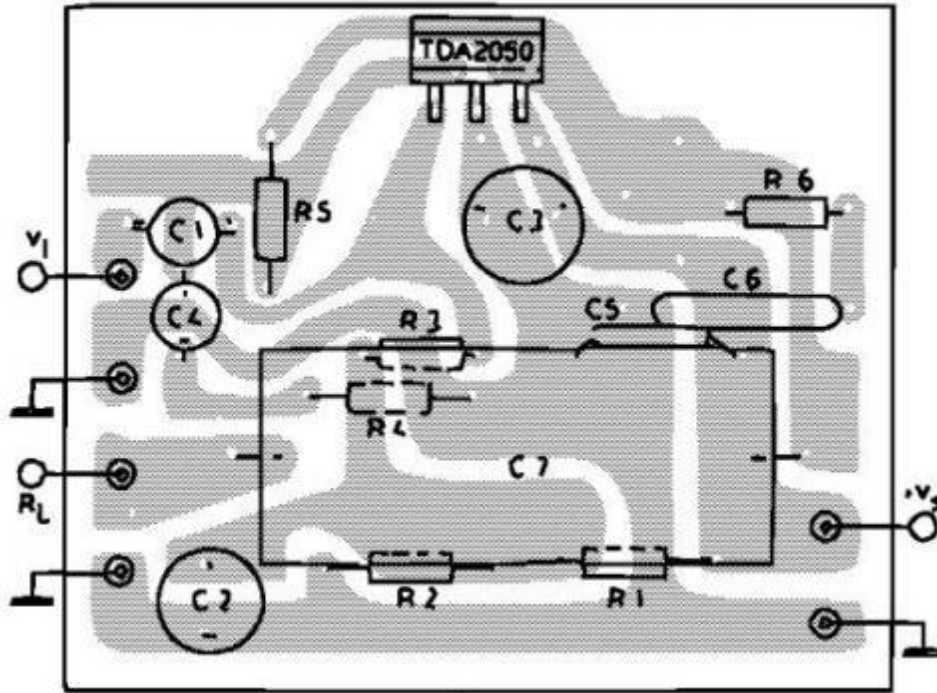

Figure 4: P.C. Board and Components Layout of the Circuit of Fig. 3 (1:1)



SINGLE SUPPLY APPLICATION SUGGESTIONS

The recommended values of the external components are those shown on the application circuit of fig. 3. Different values can be used. The following table can help the designer.

Component	Recommended Value	Purpose	Larger than Recommended Value	Smaller than Recommended Value
R1,R2,R3	22KΩ	Biassing Resistor		
R4	22KΩ	Feedback Resistors	Increase of Gain	Decrease of Gain (*)
R5	680		Decrease of Gain (*)	Increase of Gain
R6	2.2	Frequency Stability	Danger of Oscillations	
C1	2.2μF	Input Decoupling DC		Higher Low-frequency cut-off
C2	100μF	Supply Voltage Rejection	Worse Turn-off Transient Worse Turn-on Delay	
C3	1000μF	Supply Voltage Bypass		Danger of Oscillations Worse of Turn-off Transient
C4	22μF	Inverting Input DC Decoupling	Increase of Switching ON/OFF	Higher Low-frequency cut-off
C5	100nF	Supply Voltage Bypass		Danger of Oscillations
C6	0.47μF	Frequency Stability		Danger of Oscillations
C7	1000μF	Output DC Decoupling		Higher Low-frequency cut-off

(*) The gain must be higher than 24dB

NOTE

If the supply voltage is lower than 40V and the load is 8ohm (or more) a lower value of C2 can be used (i.e. 22μF). C7 can be larger than 1000uF only if the supply voltage does not exceed 40V.

TYPICAL CHARACTERISTICS (Split Supply Test Circuit unless otherwise specified)

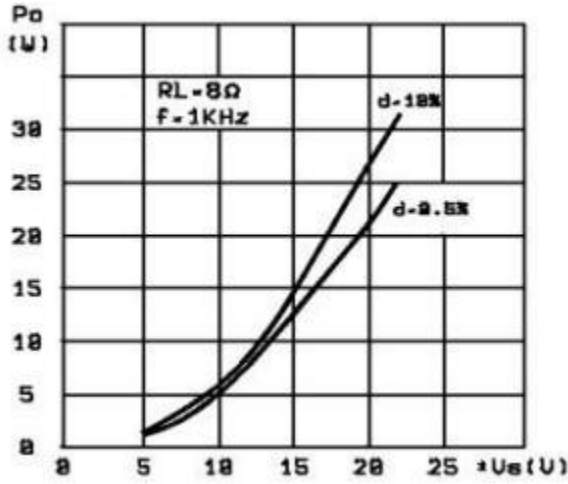

Figure 5: Output Power vs. Supply Voltage

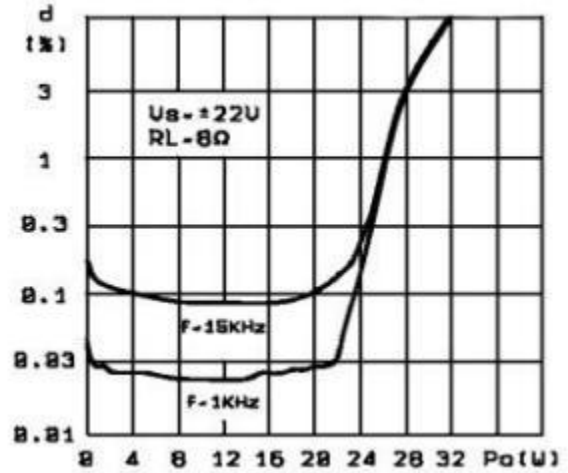

Figure 6: Distortion vs. Output Power

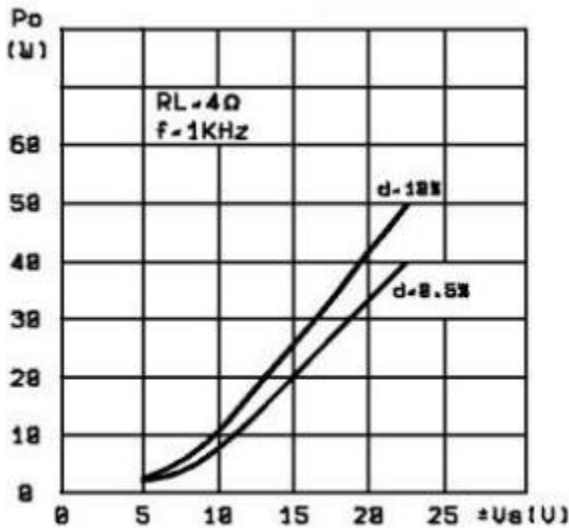

Figure 7: Output Power vs. Supply Voltage

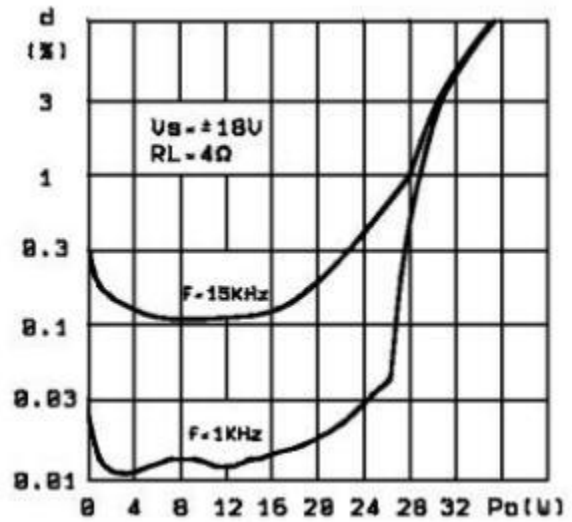

Figure 8: Distortion vs. Output Power

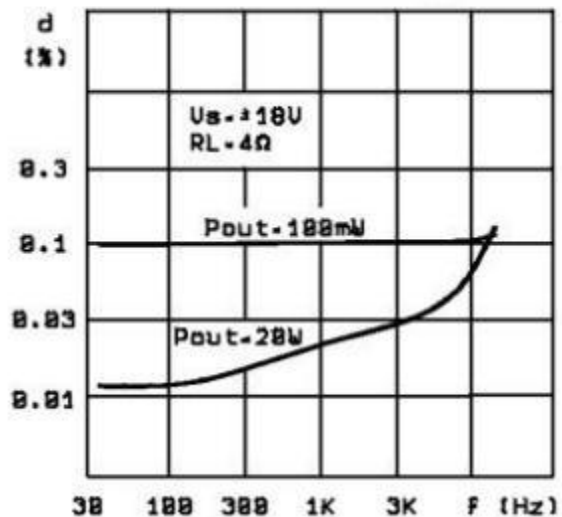
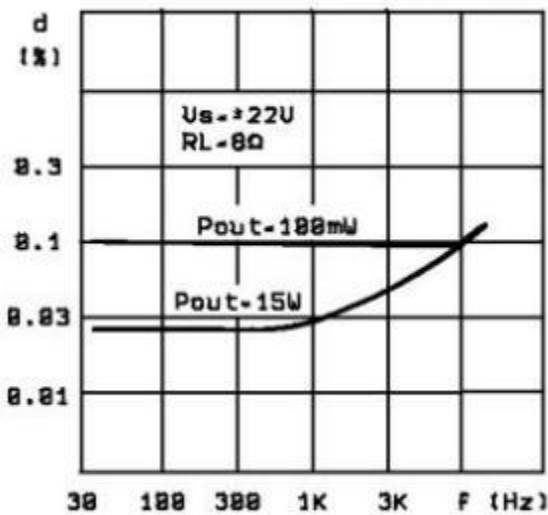

Figure 9: Distortion vs. Frequency

Figure 10: Distortion vs. Frequency

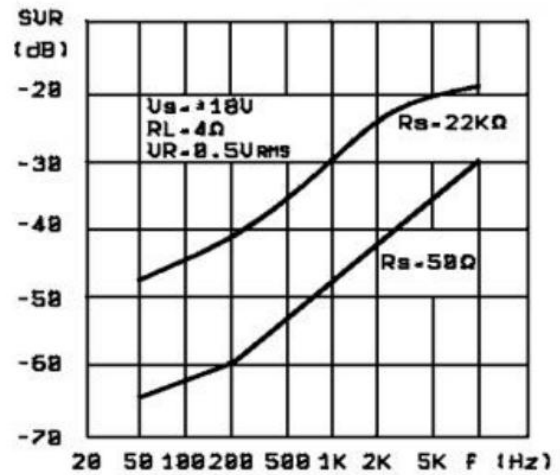
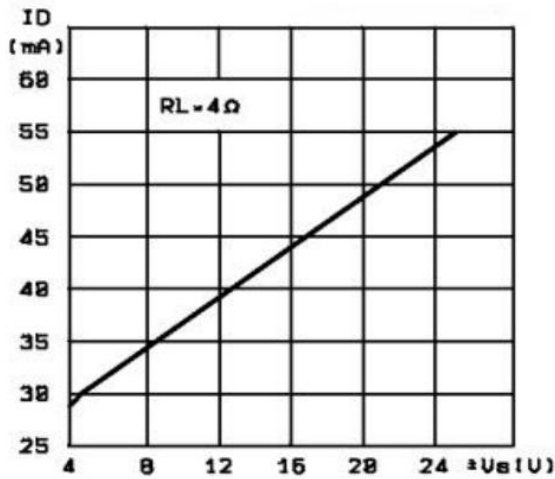

Figure 11: Quiescent Current vs. Supply Voltage

Figure 12: Supply Voltage Rejection vs. Frequency

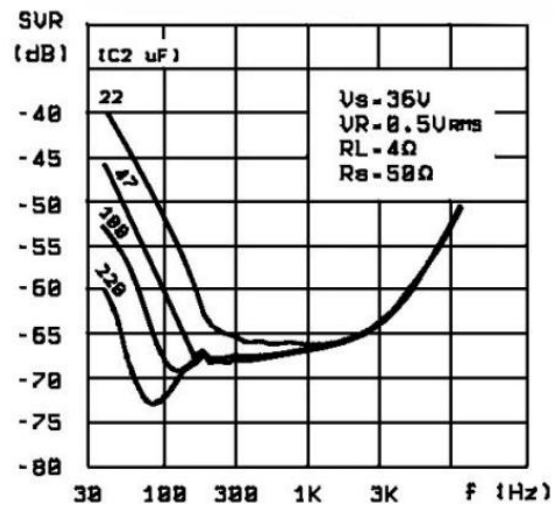
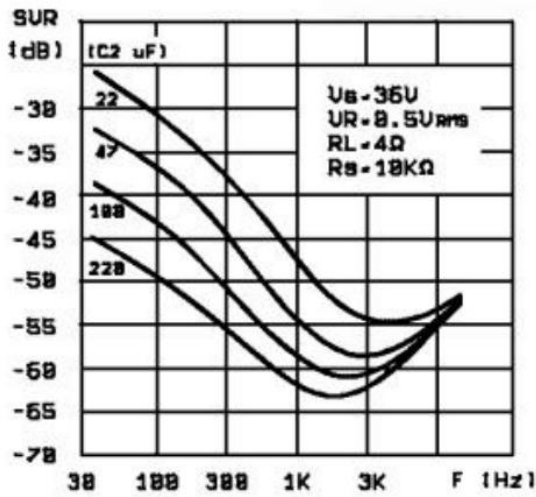

Figure 13: Supply Voltage Rejection vs. Frequency (Single supply) for Different values of C2 (circuit of fig. 3)

Figure 14: Supply Voltage Rejection vs. Frequency (Single supply) for Different values of C2 (circuit of fig. 3)

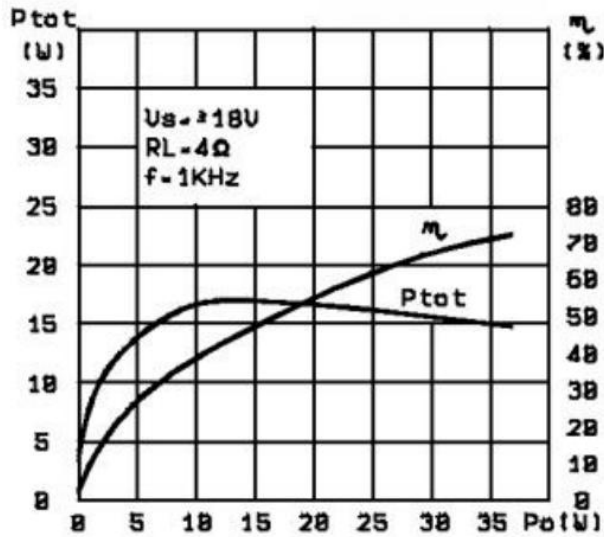

Figure 15: Total Power Dissipation and Efficiency vs. Output Power

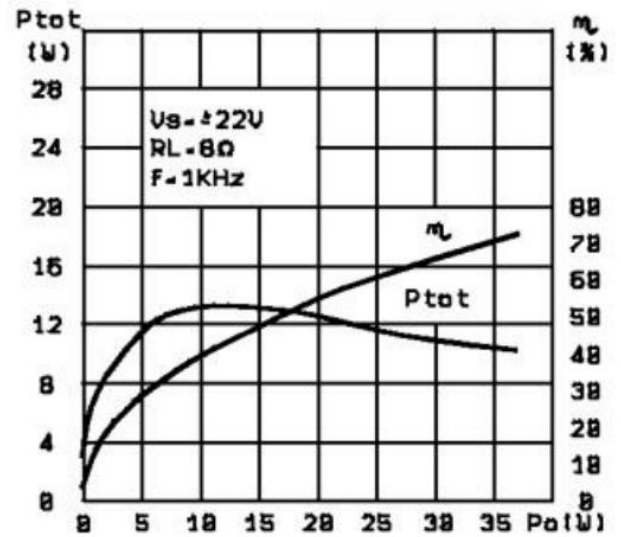

Figure 16: Total Power Dissipation and Efficiency vs. Output Power

SHORT CIRCUIT PROTECTION

The TDA2050 has an original circuit which limits the current of the output transistors. The maximum output current is a function of the collector emitter voltage; hence the output transistors work within their safe operating area. This function can therefore be considered as being peak power limiting rather than simple current limiting.

It reduces the possibility that the device gets damaged during an accidental short circuit from AC output to ground.

THERMAL SHUTDOWN

The presence of a thermal limiting circuit offers the following advantages:

- 1) An overload on the output (even if it is permanent), or an above limit ambient temperature can be easily tolerated since the T_j cannot be higher than 150°C .
- 2) The heat sink can have a smaller factor of safety compared with that of a conventional circuit. There is no possibility of device damage due to high junction temperature. If for any reason, the junction temperature increases up to 150°C , the thermal shutdown simply reduces the power dissipation and the current consumption.

The maximum allowable power dissipation depends upon the thermal resistance junction-ambient. Fig. 17 shows this dissippable power as a function of ambient temperature for different thermal resistance.

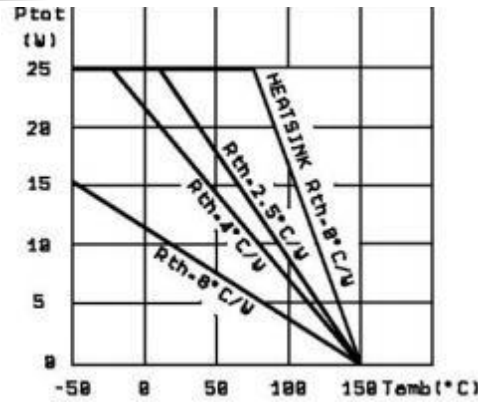

Figure 17: Maximum Allowable Power Dissipation vs. Ambient Temperature

MOUNTING INSTRUCTIONS

The power dissipated in the circuit must be removed by adding an external heat sink.

Thanks to the PENTAWATT package, the heat sink mounting operation is very simple, a screw or a compression spring (clip) being sufficient. Between the heat sink and the package is better to insert a layer of silicon grease, to optimize the thermal contact; no electrical isolation is needed between the two surfaces. Fig. 18 shows an example of heat sink.

Dimension suggestion

The following table shows the length that the heat sink in fig. 18 must have for several values of P_{tot} and R_{th}

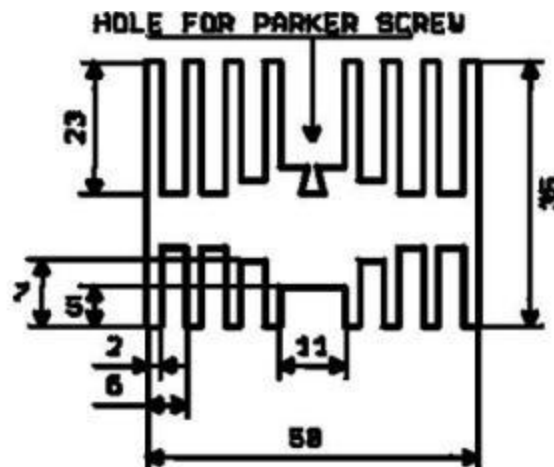

Figure 18: Example of heat-sink

APPENDIX A

A.1 - MUSIC POWER CONCEPT

MUSIC POWER is (according to the IEC clauses n.268-3 of Jan 83) the maximum power which the amplifier is capable of producing across the rated load resistance (regardless of non linearity) 1 sec after the application of a sinusoidal input signal of frequency 1 KHz.

According to this definition our method of measurement comprises the following steps:

Set the voltage supply at the maximum operating value;

- Apply a input signal in the form of a 1KHz tone burst of 1 sec duration: the repetition period of the signal pulses is 60 sec;

P_{tot} (W)	12	8	6
Lenght of heat sink (mm)	60	40	30
R_{th} of heat sink ($^{\circ}$ CW)	4.2	6.2	8.3

- The output voltage is measured 1 sec from the start of the pulse;
- Increase the input voltage until the output signal shows a THD=10%;
- The music power is then $V_{2 out} / RL$, where V_{out} is the output voltage measured in the condition of point 4 and RL is the rated load impedance;

The target of this method is to avoid excessive dissipation in the amplifier.

A.2 - INSTANTANEOUS POWER

Another power measurement (MAXIMUM INSTANTANEOUS OUTPUT POWER) was proposed by IEC in 1988 (IEC publication 268-3 subclause 19.A).

We give here only a brief extract of the concept, and a circuit useful for the measurement. The supply voltage is set at the maximum operating value.

The test signal consists of a sinusoidal signal whose frequency is 20 Hz, to which are added alternate positive and negative pulses of 50 μ s duration and 500 Hz repetition rate. The amplitude of the 20 Hz signal is chosen to drive the amplifier to its voltage clipping limits, while the amplitude of the pulses takes the amplifier alternately into its current-overload limits

A circuit for generating the test signal is given in fig. 19.

The load network consists of a 40 ∞ F capacitor, in series with a 1 ohm resistor. The capacitor limits the current due to the 20 Hz signal to a low value, whereas for he short pulses the effective load impedance is of the order of 1 ohm, and a high output current is produced.

Using this signal and load network the measurement may be made without causing excessive dissipation in the amplifier. The dissipation in the 1 ohm resistor is much lower than a rated output power of the amplifier, because the duty-cycle of the high output current is low.

By feeding the amplifier output voltage to the Xplates of an oscilloscope, and the voltage across the 1 ohm resistor (representing the output current) to the Y=plates, it is possible to read on the display the value of the maximum instantaneous output power.

The result of this test applied at the TDA 2050 is:

$$PEAK POWER = 100W \text{ typ}$$

Figure 19: Test circuit for peak power measurement

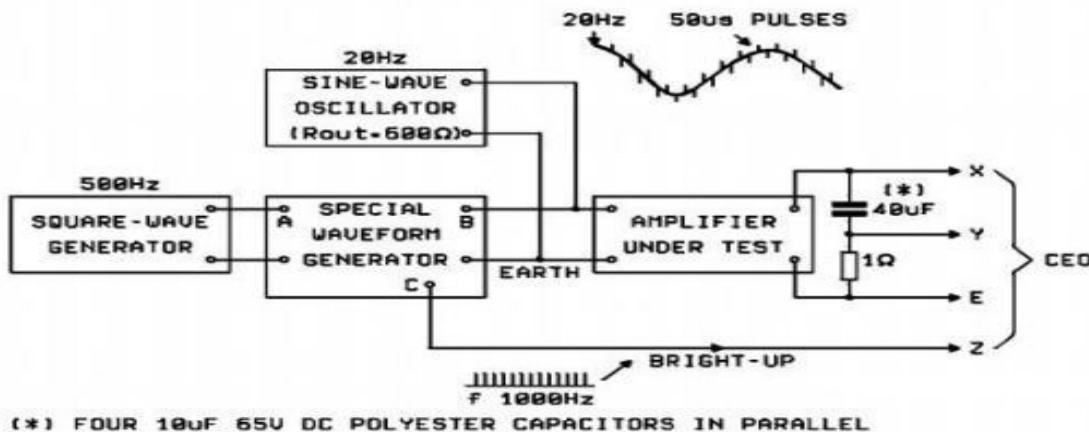

Physical Dimensions

TO-220-5L

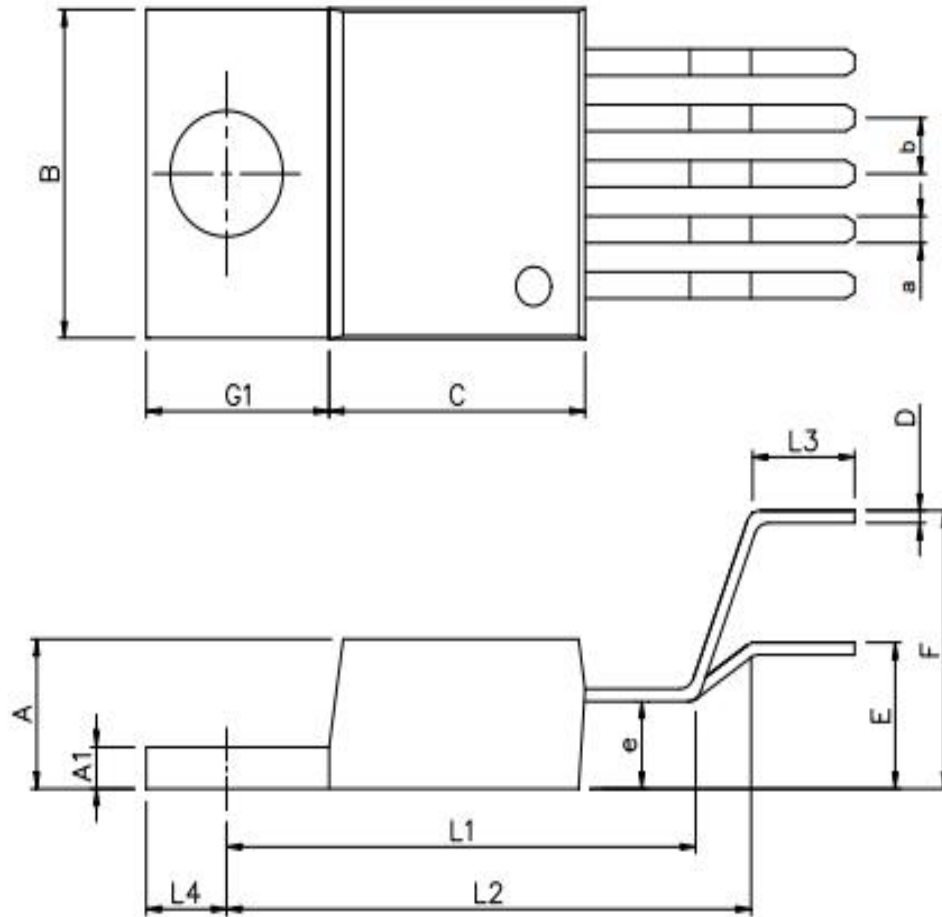

Dimensions In Millimeters(TO220-5L)

Symbol :	A	A1	B	C	C1	D	E	F	L1	L2	L3	L4	a	b	e
Min :	4.45	1.22	10	8.45	6.10	0.32	4.24	8.24	15.45	17.65	3.00	2.64	0.76	1.70	2.67
Max :	4.62	1.32	10.4	8.95	6.60	0.42	4.70	8.70	16.25	18.25	3.85	2.84	1.02	BSC	TYP

T0-263-5L Unit: mm

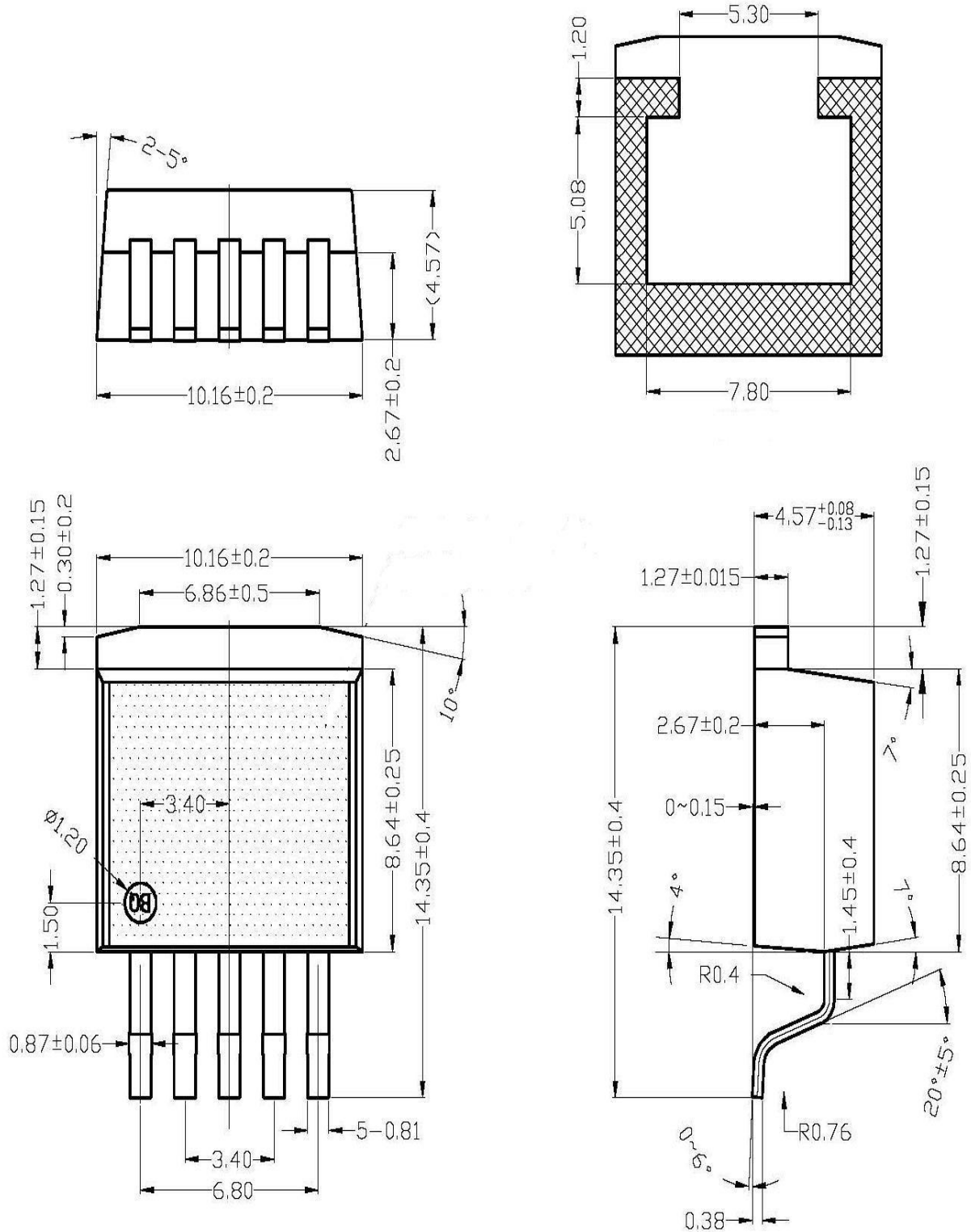

Statement:

- ◇ Shenzhen xinbole electronics co., ltd. reserves the right to change the product specifications, without notice! Before placing an order, the customer needs to confirm whether the information obtained is the latest version, and verify the integrity of the relevant information.
- ◇ Any semiconductor product is liable to fail or malfunction under certain conditions, and the buyer shall be responsible for complying with safety standards in the system design and whole machine manufacturing using Shenzhen xinbole electronics co., ltd products, and take appropriate security measures to avoid the potential risk of failure may result in personal injury or property losses of the situation occurred!
- ◇ Product performance is never ending, Shenzhen xinbole electronics co., ltd will be dedicated to provide customers with better performance, better quality of integrated circuit products.

X-ON Electronics

Largest Supplier of Electrical and Electronic Components

Click to view similar products for [Audio Amplifiers](#) category:

Click to view products by [XBLW](#) manufacturer:

Other Similar products are found below :

[LV47002P-E](#) [AZ386MTR-E1](#) [NCP2890AFCT2G](#) [NTE1192](#) [LC706200CM](#) [IS31AP4915A-QFLS2-TR](#) [TDA1591T](#) [TS2012EIJT](#)
[NCP2809BMUTXG](#) [NJW1157BFC2](#) [IS31AP4996-GRLS2-TR](#) [NCP2823BFCT1G](#) [BD88420GUL-E2](#) [LA4450L-E](#) [IS31AP2036A-CLS2-TR](#)
[NTE1110](#) [NTE7100](#) [NTE7114](#) [NTE7163](#) [NTE7168](#) [NTE7177](#) [NTE7178](#) [NTE7186](#) [NTE7198](#) [NTE7202](#) [NTE7217](#) [BD88400GUL-E2](#)
[BD88200GUL-E2](#) [SABRE9601K](#) [THAT1646W16-U](#) [PAM8965ZLA40-13](#) [TSDP10XX1NLGXZBX](#) [TSDP11XX1NKGIZBX](#)
[TSDP11XX1NLGXZBX](#) [TSDP10XX1NKGIZBX](#) [NJM4580CV-TE1](#) [NJU7084R-TE1](#) [OPA1655DR](#) [LV4910T-MPB-E](#) [NCP2890AFCT2](#)
[NCV2211DR2G](#) [SCY99091FCT2G](#) [TAS5720MRSMR](#) [AW87389FCR](#) [AW8737AFRCR](#) [TDA2005R](#) [TDA2030](#) [TDA7265L-J11-A-T](#)
[CD2050CZ](#) [AW88261FCR](#)