

RoHS

REV	ECN NO.	DESCRIPTION	DESIGN	APPROVAL	DATE
A1	NEW	更换图框			2023.11.25

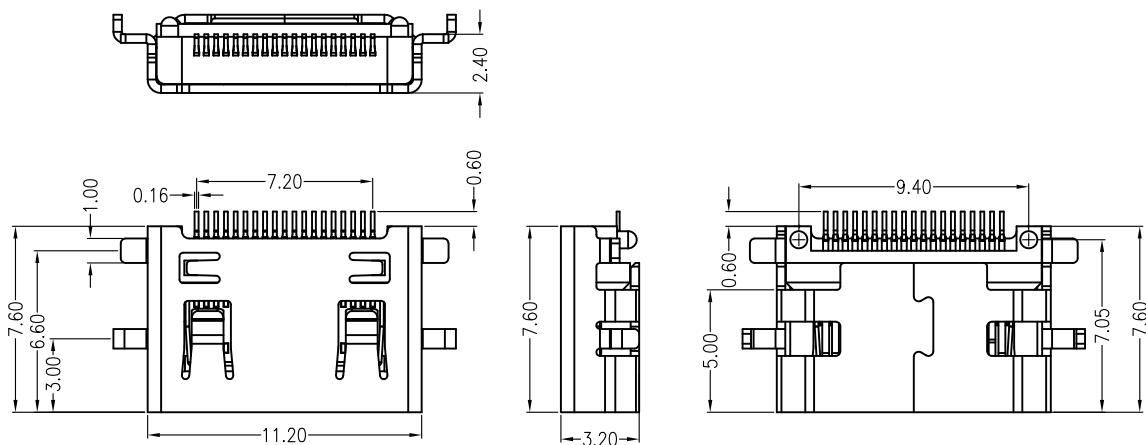

NOTES:
 1.MATERIAL:
 HOUSING:HIGH TEMPERATURE THERMOPLASTIC UL94V_0,COLOR:BLACK
 CONTACT:COPPER ALLOYS.
 COVER:SPEC
 2.PLATING:
 UNDERPLATE: NICKEL.
 CONTACT AREA:GOLD OVER NICKEL
 SOLDER AREA:TIN OVER NICKEL.
 3.MULTIMEDIA CARD COMPATIBLE

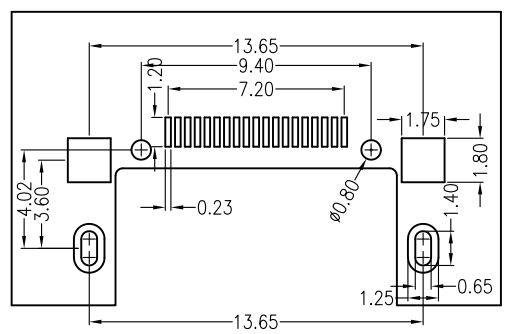
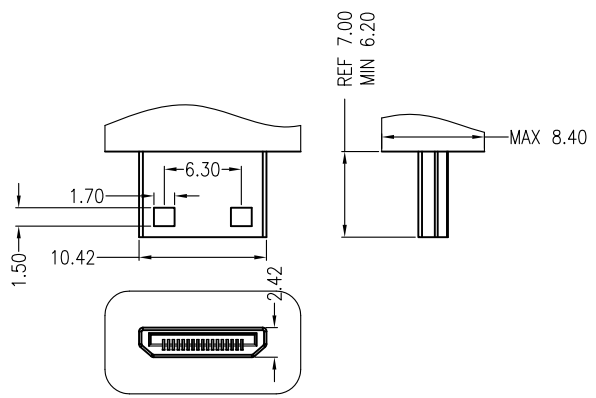
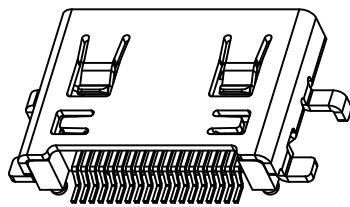
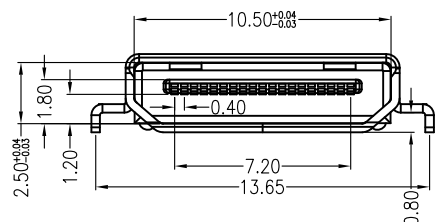

X.±0.50	X.°±	PART NO: HDS24-F1F1-2000-A	XFCN 兴飞连接器			
.XX±0.25	.X°±					0769-82001899
.XX±0.15	.XX°±		www.xfconn.com	DWG NO: /		
.XXX±0.10	.XXX°±		TITLE: MINI HDMI (C TYPE) 沉板 0.8			
UNITS:	mm	APPD				
THESE DRAWINGS AND SPECIFICATIONS ARE THE PROPERTY OF XFCN AND SHALL NOT BE REPRODUCED, COPIED OR CUED IN ANY MANNER WITHOUT THE PRIOR WRITTEN CONSENT OF XFCN		CHKD	VIEW			
		DRAW	Wang	SCALE	SHEET	REV
		DATE	2024.01.20	NONE	1:1	A1

RoHS

REV	ECN NO.	DESCRIPTION	DESIGN	APPROVAL	DATE
A1	NEW	更换图框			2023.11.25

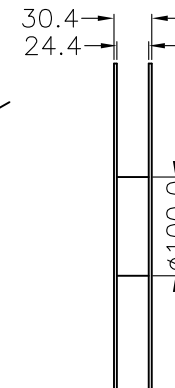
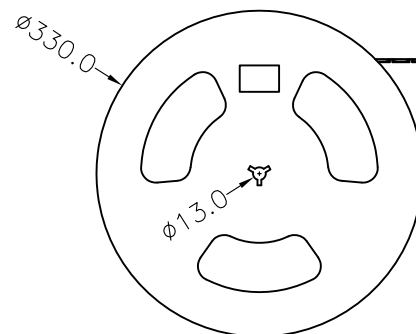
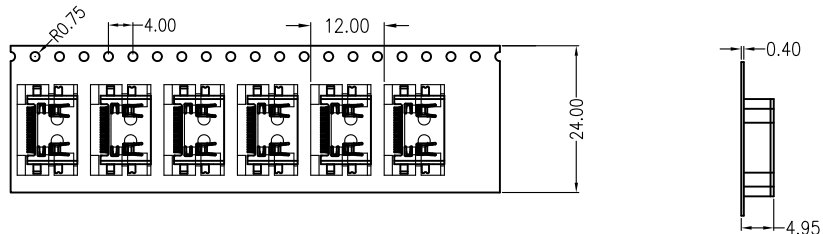

NO. 2

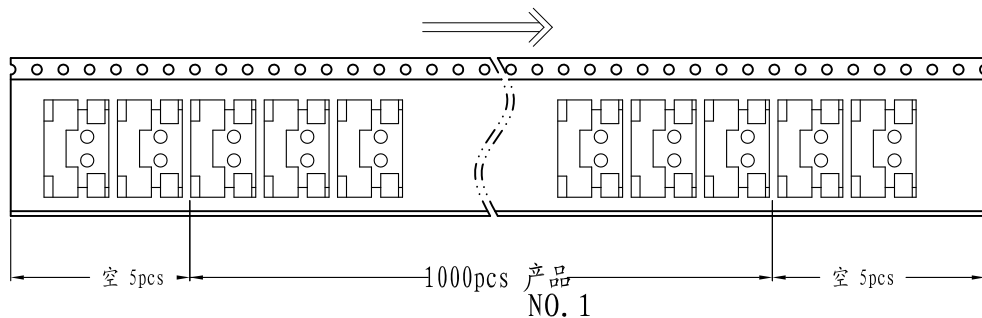

纸板

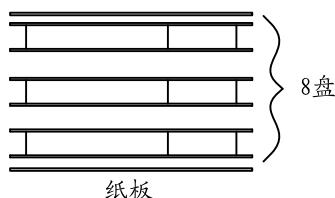

纸板

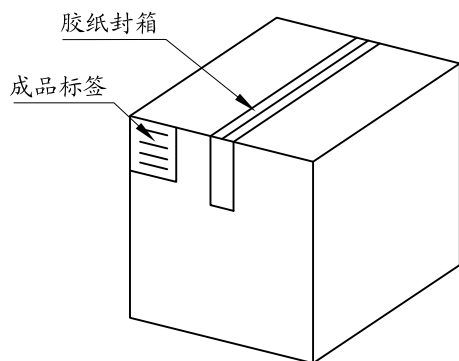

纸箱规格: 330*330*385

NO. 4

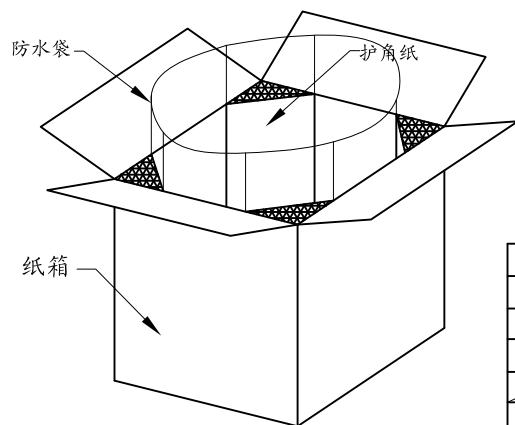

NO. 3

1. 材质要求:

- 1.1 纸箱的材质为K=K;外形尺寸为34*34*22;
- 1.2 卷盘的材质为PS,卷盘的外形尺寸为 $\phi 330*30.4$;
- 1.3 卷带的材质为PS,卷带的外形尺寸为20200*24.00*3.0mm;

2. 包装方式:

- 2.1 将卷带放入包装机后,前空5PCS,后放产品1000PCS,再后空5PCS;上带留300MM长度。
- 2.2 将包装好的产品从包装机上取下并包装好,贴上内盘标签;
- 2.3 把累叠好的7盘叠放入纸箱中共计7Kset,上下放纸板,纸箱四个角塞护角纸;
- 2.4 把包装好的成品打包封箱,并在纸箱外贴上标签

X. ± 0.50	X. $^{\circ} \pm$
.X ± 0.25	.X $^{\circ} \pm$
.XX ± 0.15	.XX $^{\circ} \pm$
.XXX ± 0.10	.XXX $^{\circ} \pm$
UNITS:	mm

THESE DRAWINGS AND SPECIFICATIONS ARE THE PROPERTY OF XFCN AND SHALL NOT BE REPRODUCED, COPIED OR CUED IN ANY MANNER WITHOUT THE PRIOR WRITTEN CONSENT OF XFCN

PART NO:		HDS24-F1F1-2000-A		XFCN 兴飞连接器	
TITLE:		MINI HDMI (C TYPE) 沉板 0.8			
APPD				0769-82001899	
CHKD				www.xfconn.com	
DRAW		Wang		DWG NO: /	
DATE		2024.01.20		VIEW	
				SCALE	
				SHEET	
				REV	
				NONE	
				2:2	
				A1	

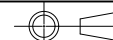

部品料号:

部品描述: HDMI C TYPE CONNECTOR

1. SCOPE 适用范围

This specification covers performance, tests and quality requirements for HDMI C TYPE CONNECTOR. These connectors are provide space savings and improved functionality to system signal transfer.

此规范包括性能, 测试及质量要求, 适用于 HDMI 高清数码接口, 提供完善的功能系统信号传输。

2. APPLICABLE DOCUMENTS 适用文件

The following documents form a part of this specification to the extent specified herein. Unless otherwise specified, latest edition of the specification applies. In the event of conflict between requirements of this specification and product drawing, product drawing shall take precedence.

下列文件构成本规范的一部分, 以本文规定的范围内。除另有规定外, 该规范的最新版本适用。在此规范之间的冲突和产品图纸要求的情况下, 产品图纸为准。

2. 1. Commercial standards, specifications and report 商业标准, 规格及报告

2. 1. 1. MIL-STD-1344A 根据MIL - STD - 1344A 标准

2. 1. 2. MIL-STD-202F 根据MIL - STD - 202F标准

3. REQUIREMENTS 要求

3.1. Design and Construction 设计与装配

Product shall be of design, construction and physical dimensions specified on applicable product drawing.

产品应在设计, 装配和结构尺寸指定适用产品图纸。

3.2. Materials and Finish 材料与处理

3. 2. 1. Contact : High performance copper alloy.
Finish : (a) Contact Area: Gold over Nickel.
(b) Solder Tail area: Tin over Nickel.

端子: 高性能铜合金。

表面处理: (a) 接触部分: 打镍底, 镀金。

(b) 焊锡区: 打镍底, 镀锡。

3. 2. 2. Housing : LCP+30%G.F, UL94V-0.

胶芯材质: LCP +30 % 玻璃纤维, 耐燃指数: UL94V - 0。

SPEC NO.

REV

B/0

ECN NO.

PAGE

1 / 4

3.3. Ratings 评定标准

- 3.3.1. Voltage : 500 Volts DC,AC(rms)250 Volts (per pin)
耐电压：500伏特直流，250伏特交流 (rms)
- 3.3.2. Current : 0.5 Amperes DC (per pin)
最大电流：0.5安培直流
- 3.3.3. Operating Temperature : -25°C TO +85°C
使用温度：-25°C至+85°C

3.4. Performance and Test Description 性能及测试说明

Product is designed to meet electrical, mechanical and environmental performance requirements specified in Paragraph 3.5. All tests are performed at ambient environmental conditions per MIL-STD-1344A unless otherwise specified.

产品的目的是为了满足不同电气、机械和环境性能要求在指定的第 3.5 节。所有测试是在常压环境条件按照 MIL - STD- 1344A 完成除非另有说明。

3.5. Test Requirements and Procedures Summary 测试要求和程序说明。

Test Description 测试说明	Finally 测试结果	Condition 测试条件					
ELECTRICAL (电气)							
Low-Signal Level Contact Resistance 接触电阻测试	R<80 mΩ 电阻小于 80m Ω	Subject mated contacts assembled in housing to closed circuit of 10 mA max. at open circuit voltage of 20 mV max. 所述固定在外壳里的端子联结到一个封闭回路中测试：电流10mA，电压20 mV max.					
Insulation Resistance 绝缘电阻测试	R>1000 MΩ 绝缘电阻大于1000M Ω	Apply DC 500±10% Volts between adjacent contacts of mated connectors for one minute. MIL-STD-202F, Method 302 500±10 %伏特之间的相邻或接触交配连接器为一分钟。 根据 MIL - STD - 202F, 方法 302。					
Dielectric Withstanding Voltage 介质耐电压	No discharge, flashover or breakdown. 没有放电, 烧焦或击穿。	500 V initial and 250 Vfinal for 1 minute. MIL-STD-202F, Method 301 500V 和 250V 持续一分钟。 根据 MIL - STD - 202F, 方法 301。					
SPEC NO.		REV	B/0	ECN NO.		PAGE	2 / 4

XFCN 东莞市兴飞连接器有限公司

Insertion/Withdrawal Force 插入/拔出力	插入力小于0.7kg(6.9N) 拔出力大于1.0kg(9.8N)	Mate connector with a suitable gauge at rate of 25 mm/min. MIL-STD-1344A, Method 2012.1 用连接器与一个合适的拉力计，在速度为25毫米/每分钟情况下。 根据 MIL - STD - 1344A, 方法 2012.1					
Retention Force 端子保持力	100 Gram(0.98N) minimum(per pin) 每 pin 最小 100 克 (0.98N) 。	Mate connector with a suitable gauge for each pin at rate of 25 mm/min. MIL-STD-1344A, Method 2012.1 用连接器与一个合适的拉力计，每个管脚在速度为 25 毫米/每分钟情况下。 根据 MIL - STD - 1344A, 方法 2012.1					
Vibration 振动测试	Discontinuity 1.0 us. MAX 瞬断不超过1微秒。	Mate dummy card and subject to following Vibration conditions for a period of 2 hours in each of 3 mutually perpendicular axes, passing DC 1 mA during Amplitude: 1.52 mm P-P Frequency: 10-55-10 Hz Shall be traversed in 1 minute (MIL STD - 202 Method 201) 振幅: 1.52毫米P-P 频率: 10-55-10赫兹 每种频率持续一分种循环					
Durability 寿命周期测试	5000 cycles. 插拔 5000 次。	The sample should be mounted in the at the rate of 25mm/min. MIL-STD-1344A, Method 2016 样品应装在试验机，在指定的速 25mm/min。 根据 MIL - STD - 1344A, 方法 2016					
Solderability 可焊性测试	Solderable area shall have minimum of 95% solder coverage. 可焊面积大于 95 %	Subject the test area of contacts into flux for 3±0.5 seconds and then into solder bath, controlled at 270±5℃, for 3±0.5 seconds. 持需焊部分放入锡炉，温度控制在270 ± 5 ℃，为3 ± 0.5秒。					
ENVIRONMENTAL (环境)							
Salt Spray 氧化测试	Oxidation of not more than 5%. 氧化面积不超过5%。	Subject mated/unmated connectors to 5±1% salt-solution concentration, 35℃±2℃ for 24 hours (Gold over for 24 H, Nickel for 24 H, Tin for 24 H, Tin for 8 H) . MTL-STD-1344A, Method 1001.1, 以5 ± 1 %的盐溶液浓度, 35 ℃ ± 2 ℃, 24小时(镀金区域24小时, 镀镍区域24小时, 镀锡区域8小时)。MTL-STD-1344A 1001.1					
SPEC NO.		REV	B/O	ECN NO.		PAGE	3 / 4

XFCN 东莞市兴飞连接器有限公司

<p>Temperature Life (Heat Aging) (Heat Resistance) 高温测试 (热老化) (耐热)</p>	<p>A. Products in $85\text{ }^{\circ}\text{C} \pm 2\text{ }^{\circ}\text{C}$ 96 hours, the product can still be used normally. B. Products in the $260\text{ }^{\circ}\text{C} \pm 5\text{ }^{\circ}\text{C}$ or eight of the reflow temperature (10 second), the deformation of not more than 0.12 mm. A. 产品在$85^{\circ}\text{C} \pm 2^{\circ}\text{C}$ 96小时, 产品仍可正常使用。 B. 产品经过八温段回流焊最高温度在$260^{\circ}\text{C} \pm 5^{\circ}\text{C}$ (10秒), 变形不超过0.12mm。</p>	<p>MTL-STD-202F, Method 108A,</p>					
SPEC NO.		REV	B/0	ECN NO.		PAGE	4 / 4

X-ON Electronics

Largest Supplier of Electrical and Electronic Components

Click to view similar products for [D-Sub Standard Connectors](#) category:

Click to view products by [XFCN](#) manufacturer:

Other Similar products are found below :

[015-0339-000](#) [015-0341-000](#) [015-0349-000](#) [015-0350-000](#) [015-8544-011](#) [015-8755-001](#) [017041-0005](#) [020419-0104](#) [609-25P](#) [609-9P](#)
[M24308/2-23Z](#) [CT0-24-10SC](#) [CT0-36-3PC](#) [CT0E20-8PS](#) [CT0F16S-1PS](#) [CT0TA16-11SXCA232](#) [CT1E20-19SS](#) [CT2-10SL-3SC](#) [CT2-14S-2PCA34](#) [CT2-18-11PCAU](#) [CT2-22-19SC](#) [CT2-36-5PC](#) [CT6-10SL-3SC](#) [CT6-10SL-4SC](#) [CT6-14S-2SC](#) [CT6-16-12SC](#) [CT6-18-10PSA206](#)
[CT6-18-10PSA232](#) [CT6-18-11PXSA206](#) [CT6-18-11PXSA232](#) [CT6-22-10PS](#) [CT6-24-5PC](#) [CT6-9767-18-8-18-4SS](#) [CT6E14S-5SC](#)
[CT6E14SA7SC](#) [CT6E20-14SS](#) [CT6E22-14PC](#) [CT6E22-14PS](#) [CT6E22-19PS](#) [CT6E22-22PS](#) [CT6E24-10SC](#) [CT6F16S-1SC](#) [CT6FA10SL-4PS](#)
[CT6LA20-19PC](#) [CT6M20-19SS](#) [CT6NSB4-20-8SS](#) [CT6TC14S-6SCAU](#) [CT6TC14S-7PS](#) [6STD15SCT99S40X](#) [6STF09PCM05B70X](#)