



FEATURES

- Slew rate: 6.1V/ μ s
- Bandwidth: 6.6MHz
- Input/Output full swing
- Low supply current: 2.6mA (Typical)
- Offset Voltage: 5.1 μ V (Typical)
- Supply Voltage: 2.2V to 5.5V
- Operation Temperature Range: -40°C to 125°C
- Micro Size Packages: TSSOP and SOIC

APPLICATIONS

- ADC buffer
- Audio equipment
- Instrument circuit
- Stress test circuit
- Current measuring circuit
- Consumer electronics

GENERAL DESCRIPTION

The MT076X series are single, dual, and quad rail-to-rail CMOS operational amplifiers with low noise and low quiescent current. These amplifiers have the characteristics of input/output full swing, low offset, low power and stable high frequency response. These amplifiers achieve very good AC performance with 6.6MHz bandwidth, 6.1V/ μ s slew rate and low distortion while drawing only 650 μ A of quiescent current per amplifier. These amplifiers have the characteristics of low input bias current and high open-loop gain. This product adopts rail to rail input and output design, with 5.1 μ V offset voltage and extremely low noise.

MT076X has wide temperature range from -40°C to +125°C.

Single or dual supplies as low as 2.2V (\pm 1.1V) and up to 5.5V (\pm 2.75V) can be used. And these amplifiers have good PSRR characteristics, as a result of that, they can be powered by battery without voltage regulator.

The MT0764 is available in the 14-Pin TSSOP and SOIC packages.

SIMPLIFIED SCHEMATIC

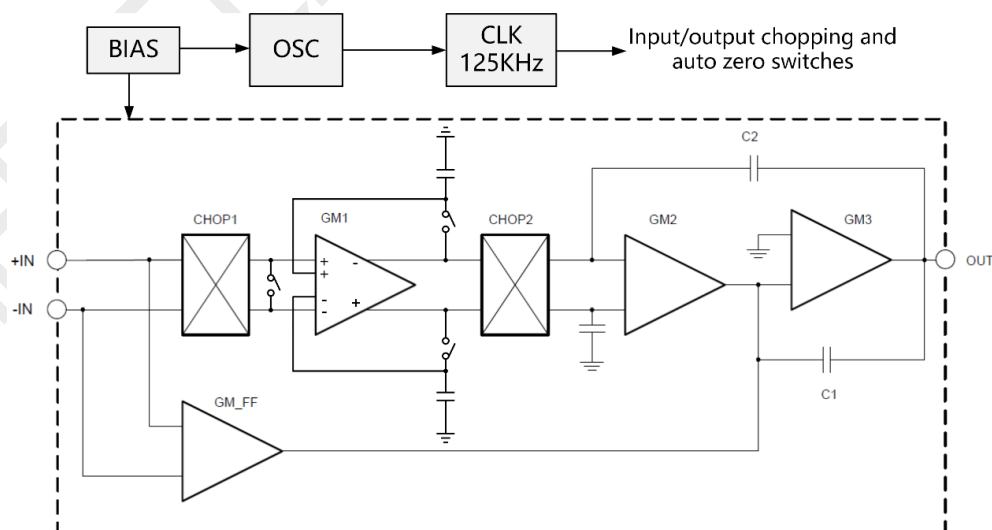

Figure 1. Simplified schematic

ABSOLUTE MAXIMUM RATINGS (Note 1)

Supply Voltage..... +2.2V to +5.5V
 Input Offset Voltage..... 5.1 μ V(typical)
 Input Offset Current..... 91pA(typical)
 Maximum Operating Junction Temperature..... 150°C
 Operating Temperature Range..... -40°C to 125°C
 Storage Temperature -65°C to 150°C

PACKAGE/ORDER INFORMATION

TOP VIEW	Order Part Number	Package	Top Marking
	MT0764	14-Pin TSSOP 14-Pin SOIC	MT0764CG MT0764CJ

DEVICE INFORMATION

Order Part Number	Top Marking	Package
MT0764	MT0764CG	TSSOP-14
	MT0764CJ	SOIC-14

PIN DESCRIPTION

Pin Name	Pin Number	Description
OUTA	-	Output of channel A
-INA	-	Inverting input of channel A
+INA	-	Noninverting input of channel A
-V	-	Positive (highest) power supply
+INB	-	Noninverting input of channel B
-INB	-	Inverting input of channel B
OUTB	-	Output of channel B
OUTC	-	Output of channel C

-INC	-	Inverting input of channel C
+INC	-	Noninverting input of channel C
+V	-	Negative(lowest) power supply
+IND	-	Noninverting input of channel D
-IND	-	Inverting input of channel D
OUTD	-	Output of channel D

ELECTRICAL CHARACTERISTICS (Note 3)

(At $T_A = 25^\circ\text{C}$, $+V_S = +2.5\text{V}$, $-V_S = -2.5\text{V}$, $R_L = 10\text{K}\Omega$, $C_L = 0$, unless otherwise noted.)

PARAMETER	CONDITIONS	MIN	TYP	MAX	UNIT
Input Offset Voltage	$V_S = 5.0\text{V}$		5.1	25	mV
Input Offset Voltage Drift	$T_A = -40^\circ\text{C}$ to 125°C		0.3		$\mu\text{V}/^\circ\text{C}$
Input Bias Current	$T_A = 25^\circ\text{C}$		283		pA
Input Offset Current			91		pA
Power Supply Rejection Ratio			124		dB
Common-mode Rejection Ratio			132		dB
Open Loop Voltage Gain	$R_L = 10\text{K}\Omega$, $C_L = 0\text{pF}$		123		dB
Gain-bandwidth product	$R_L = 0\Omega$, $C_L = 100\text{pF}$, $V_{DD} = 5.5\text{V}$		6.6		MHz
Slew Rate	$G = +1$, $R_L = 0\Omega$, $C_L = 100\text{pF}$, $V_{DD} = 5.5\text{V}$		6.1		$\text{V}/\mu\text{s}$
Input Voltage Noise	$f = 0.1\text{Hz}$ to 10Hz		0.8		μV_{PP}
Input Voltage Noise Density	$f = 1\text{kHz}$		7.5		$\text{nV}/\sqrt{\text{Hz}}$
Supply Current (per amplifier)			650		μA
Operating Temperature Range		-40		125	$^\circ\text{C}$
Storage Temperature Range		-65		150	$^\circ\text{C}$

Note 1: Absolute Maximum Ratings are those values beyond which the life of a device may be impaired.

Note 2: T_J is calculated from the ambient temperature T_A and power dissipation P_D according to the following formula: $T_J = T_A + (P_D) \times (170^\circ\text{C}/\text{W})$.

Note 3: 100% production test at +25°C. Specifications over the temperature range are guaranteed by design and characterization.

AEROSEMI CONFIDENTIAL

TYPICAL PERFORMANCE CHARACTERISTICS

(At $T_A = 25^\circ\text{C}$, $+V_S = +2.5\text{V}$, $-V_S = -2.5\text{V}$, $R_L = 2\text{k}\Omega$, $C_L = 100\text{pF}$, unless otherwise noted.)

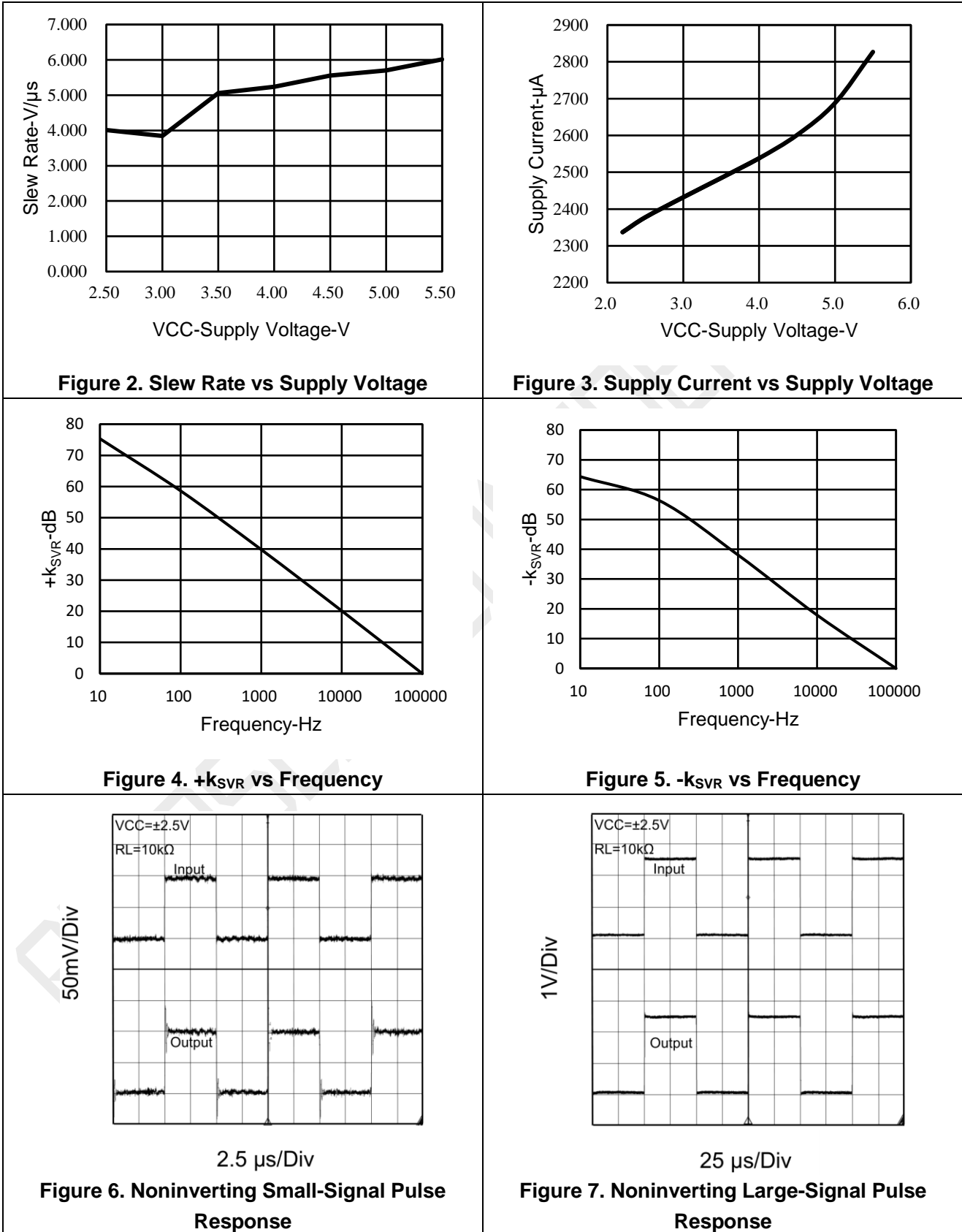

TYPICAL PERFORMANCE CHARACTERISTICS

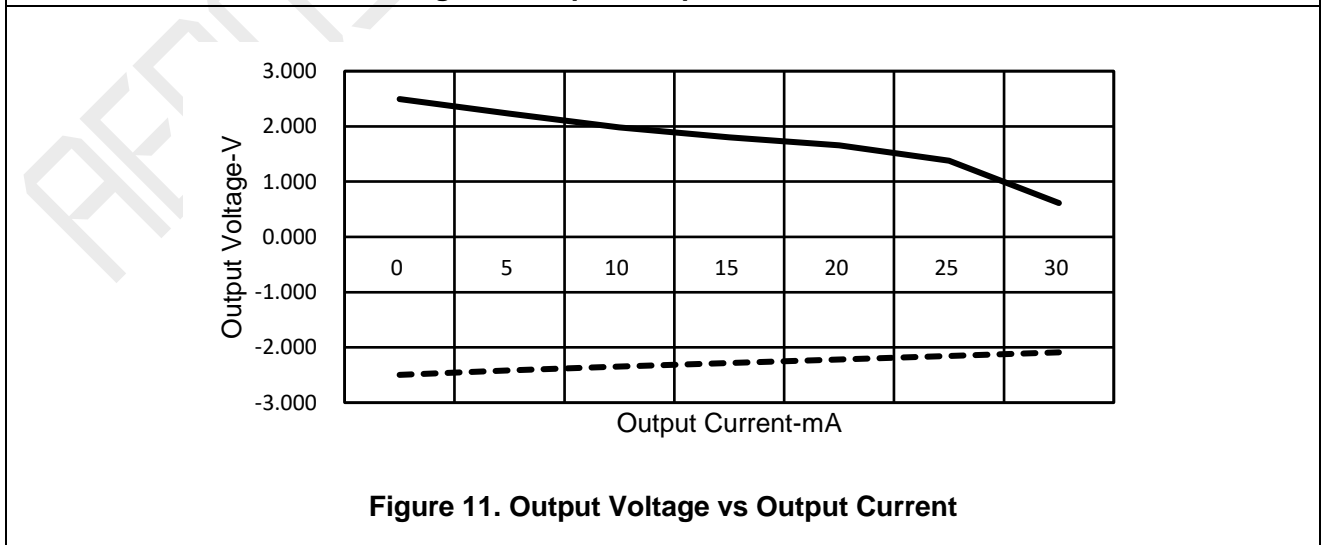
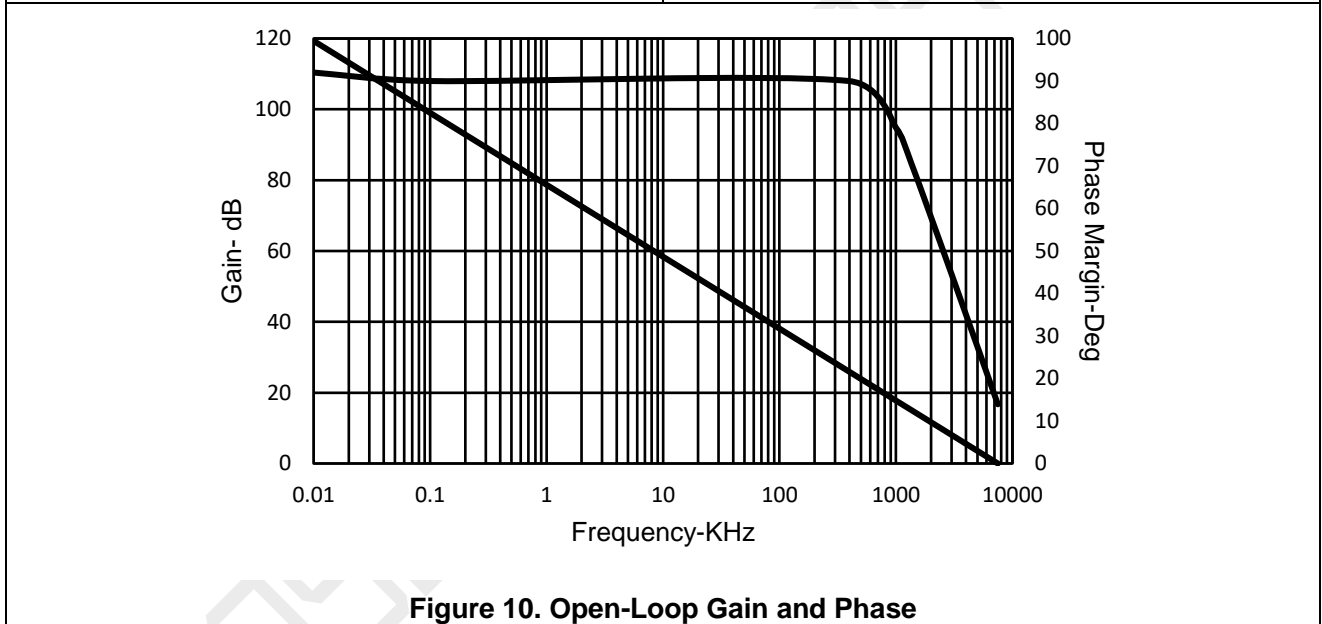
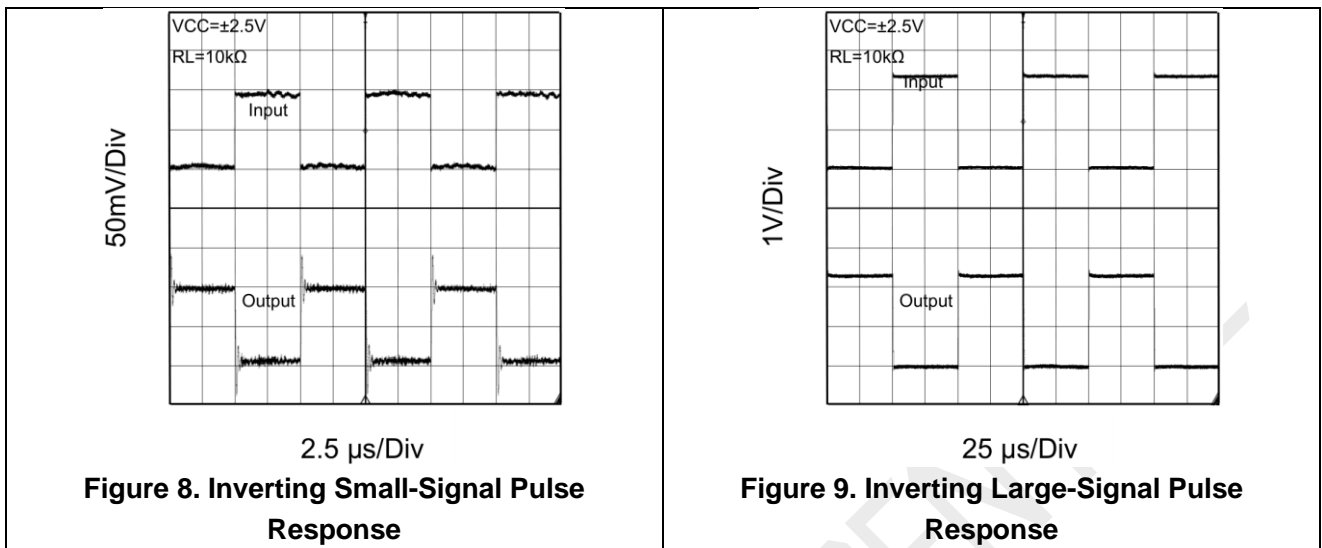

APPLICATIONS INFORMATION

MT076X are low supply voltage CMOS operational Amplifiers. This amplifier has the characteristics of Input/Output full swing, high slew rate, low supply current and high speed operation. MT076X has wide temperature range from -40°C to $+85^{\circ}\text{C}$. Single or dual supplies as low as $2.2\text{V}(\pm 1.1\text{V})$ and up to $5.5\text{V}(\pm 2.75\text{V})$ can be used.

Voltage follower

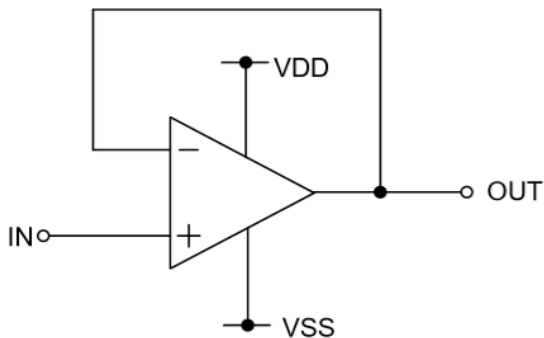

Figure 12. Voltage follower

Voltage gain is 0dB. Using this circuit, the output voltage (OUT) is configured to be equal to the input voltage (IN). This circuit also stabilizes the output voltage (OUT) due to high input impedance and low output impedance. Computation for output voltage (OUT) is shown below. $\text{OUT} = \text{IN}$.

Inverting amplifier

For inverting amplifier, input voltage (IN) is amplified by a voltage gain and depends on the ratio of R1 and R2. The out-of-phase output voltage is shown in the next expression

$$\text{OUT} = -(\text{R2}/\text{R1}) \cdot \text{IN}$$

This circuit has input impedance equal to R1.

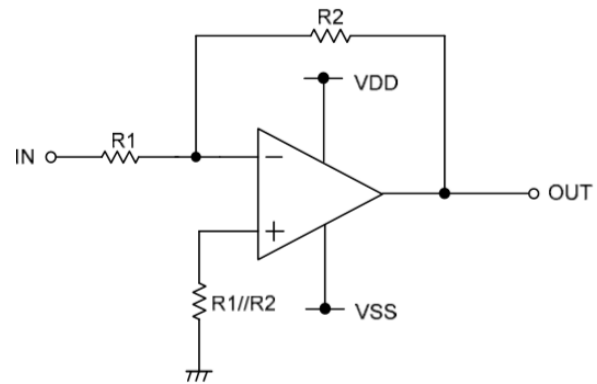

Figure 13. Inverting amplifier circuit

Non-inverting amplifier

For non-inverting amplifier, input voltage (IN) is amplified by a voltage gain, which depends on the ratio of R1 and R2. The output voltage (OUT) is in-phase with the input voltage (IN) and is shown in the next expression.

$$\text{OUT} = (1 + \text{R2}/\text{R1}) \cdot \text{IN}$$

Effectively, this circuit has high input impedance since its input side is the same as that of the operational amplifier.

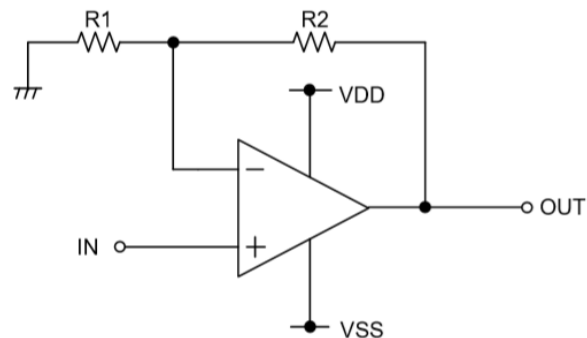
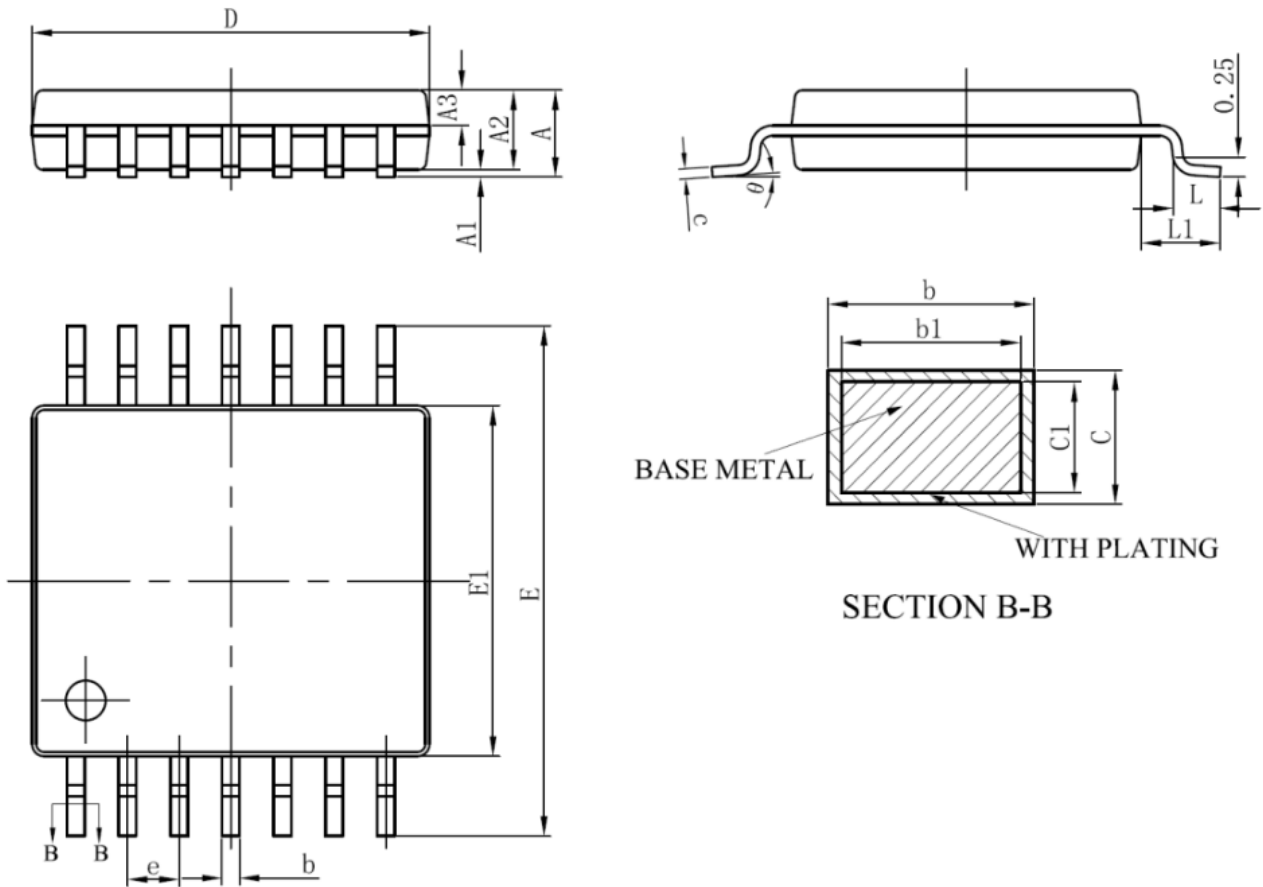

Figure 14. Non-inverting amplifier circuit

PACKAGE DESCRIPTION

TSSOP-14



SYMBOL	millimeter		
	min	nom	max
A	-	-	1.20
A1	0.05	-	0.15
A2	0.90	1.00	1.05
A3	0.39	0.44	0.49
b	0.20	-	0.28
b1	0.19	0.22	0.25
c	0.13	-	0.17
c1	0.12	0.13	0.14
D	4.90	5.00	5.10
E1	4.30	4.40	4.50
E	6.20	6.40	6.60
e	0.65BSC		
L	0.45	0.60	0.75
L1	1.00REF		
θ	0	-	8°

SOIC

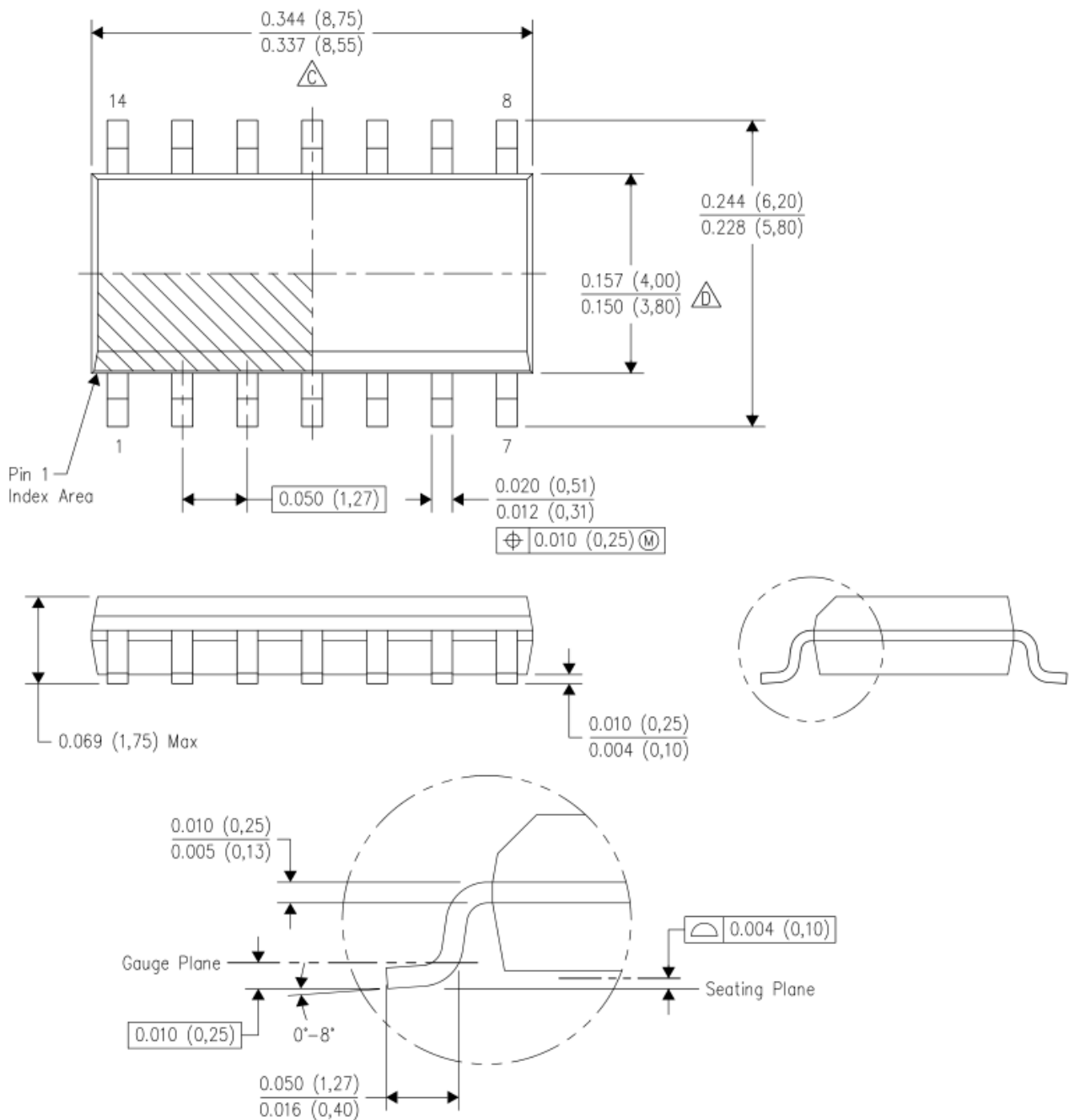

NOTES:

1. All linear dimensions are in millimeters. Any dimensions in parenthesis are for reference only. Dimensioning and tolerancing per ASME Y14.5M.
2. This drawing is subject to change without notice.
3. Reference JEDEC MO-178.
4. Body dimensions do not include mold flash, protrusions, or gate burrs. Mold flash, protrusions, or gate burrs shall not exceed 0.15 mm per side.

IMPORTANT NOTICE

Xi'an Arosemi Technology Co.,Ltd reserve the right to make corrections, enhancements, improvements and other changes to its semiconductor products and services.

Xi'an Arosemi Technology Co.,Ltd is not responsible or liable for such altered documentation. Information of third parties may be subject to additional restrictions.

Xi'an Arosemi Technology Co.,Ltd does not assume any responsibility for use of any its products for any particular purpose, nor does Xi'an Arosemi Technology Co.,Ltd assume any liability arising out of the application or use of any its products or circuits.

Copyright © 2011, Xi'an Arosemi Technology Co.,Ltd

Tel: 0755-82879616 021-50871055 029-88868021

Http://www.arosemi.com

E-Mail: sales@arosemi.com

AEROSEMI CONFIDENTIAL

X-ON Electronics

Largest Supplier of Electrical and Electronic Components

Click to view similar products for [Operational Amplifiers - Op Amps](#) category:

Click to view products by [XIAN Aerosemi Tech](#) manufacturer:

Other Similar products are found below :

[430227FB](#) [LT1678IS8](#) [NCV33202DMR2G](#) [NJM324E](#) [M38510/13101BPA](#) [NTE925](#) [AZV358MTR-G1](#) [AP4310AUMTR-AG1](#)

[AZV358MMTR-G1](#) [SCY33178DR2G](#) [NCV20034DR2G](#) [NTE778S](#) [NTE871](#) [NTE937](#) [NJU7057RB1-TE2](#) [SCY6358ADR2G](#)

[NJM2904CRB1-TE1](#) [UPC4570G2-E1-A](#) [UPC4741G2-E1-A](#) [NJM8532RB1-TE1](#) [EL2250CS](#) [EL5100IS](#) [EL5104IS](#) [EL5127CY](#) [EL5127CZY](#)

[EL5133IW](#) [EL5152IS](#) [EL5156IS](#) [EL5162IS](#) [EL5202IY](#) [EL5203IY](#) [EL5204IY](#) [EL5210CS](#) [EL5210CZY](#) [EL5211IYE](#) [EL5220CY](#)

[EL5223CLZ](#) [EL5223CR](#) [EL5224ILZ](#) [EL5227CLZ](#) [EL5227CRZ](#) [EL5244CS](#) [EL5246CS](#) [EL5246CSZ](#) [EL5250IY](#) [EL5251IS](#) [EL5257IS](#)

[EL5260IY](#) [EL5261IS](#) [EL5300IU](#)