

Summary

The Xilinx Automotive (XA) Spartan[®]-3A DSP family of FPGAs solves the design challenges in most high-volume, cost-sensitive, high-performance DSP automotive applications. The two-member family offers densities ranging from 1.8 to 3.4 million system gates, as shown in [Table 1](#).

Introduction

XA devices are available in both extended-temperature Q-Grade (–40°C to +125°C T_J) and I-Grade (–40°C to +100°C T_J) and are qualified to the industry recognized AEC-Q100 standard.

The XA Spartan-3A DSP family builds on the success of the earlier XA Spartan-3E and XA Spartan-3 FPGA families by adding hardened DSP MACs with pre-adders, significantly increasing the throughput and performance of this low-cost family. These XA Spartan-3A DSP family enhancements, combined with proven 90 nm process technology, deliver more functionality and bandwidth per dollar than ever before, setting the new standard in the programmable logic industry.

Because of their exceptionally low cost, XA Spartan-3A DSP FPGAs are ideally suited to a wide range of automotive electronics applications, including infotainment, driver information, and driver assistance modules.

The XA Spartan-3A DSP family is a superior alternative to mask programmed ASICs. FPGAs avoid the high initial mask set costs and lengthy development cycles, while also permitting design upgrades in the field with no hardware replacement necessary because of its inherent programmability, an impossibility with conventional ASICs and ASSPs with their inflexible architecture.

Features

- Very low cost, high-performance DSP solution for high-volume, cost-conscious applications
- 250 MHz DSP48A slices using XtremeDSP™ solution
 - Dedicated 18-bit by 18-bit multiplier
 - Available pipeline stages for enhanced performance of at least 250 MHz in the standard -4 speed grade
 - 48-bit accumulator for multiply-accumulate (MAC) operation
 - Integrated adder for complex multiply or multiply-add operation
 - Integrated 18-bit pre-adder
 - Optional cascaded Multiply or MAC
- Dual-range V_{CCAUX} supply simplifies 3.3V-only design
- Suspend and Hibernate modes reduce system power
- Multi-voltage, multi-standard SelectIO™ interface pins
 - Up to 519 I/O pins or 227 differential signal pairs
 - LVCMOS, LVTTTL, HSTL, and SSTL single-ended I/O
 - 3.3V, 2.5V, 1.8V, 1.5V, and 1.2V signaling
 - Selectable output drive, up to 24 mA per pin
 - QUIETIO standard reduces I/O switching noise
 - Full 3.3V ± 10% compatibility and hot-swap compliance
 - 622+ Mb/s data transfer rate per differential I/O
 - LVDS, RSDS, mini-LVDS, HSTL/SSTL differential I/O with integrated differential termination resistors
 - Enhanced Double Data Rate (DDR) support
 - DDR/DDR2 SDRAM support up to 266 Mb/s
 - Fully compliant 32-bit, 33 MHz PCI[®] technology support
- Abundant, flexible logic resources
 - Densities up to 53,712 logic cells, including optional shift register
 - Efficient wide multiplexers, wide logic
 - Fast look-ahead carry logic
 - IEEE 1149.1/1532 JTAG programming/debug port
- Hierarchical SelectRAM™ memory architecture
 - Up to 2,268 Kbits of fast block RAM with byte write enables for processor applications
 - Up to 373 Kbits of efficient distributed RAM
 - Registered outputs on the block RAM with operation of at least 280 MHz in the standard -4 speed grade
- Eight Digital Clock Managers (DCMs)
 - Clock skew elimination (delay locked loop)
 - Frequency synthesis, multiplication, division
 - High-resolution phase shifting
 - Wide frequency range (5 MHz to over 320 MHz)
- Eight low-skew global clock networks, eight additional clocks per half device, plus abundant low-skew routing
- Configuration interface to industry-standard PROMs
 - Low-cost, space-saving SPI serial Flash PROM
 - x8 or x8/x16 parallel NOR Flash PROM
 - Unique Device DNA identifier for design authentication
- Complete Xilinx [ISE[®]](#) and [WebPACK™](#) software support plus [Spartan-3A DSP FPGA Starter Kit](#)
- [MicroBlaze™](#) and [PicoBlaze™](#) embedded processor cores
- BGA packaging, Pb-free only
 - Common footprints support easy density migration

Table 1: Summary of XA Spartan-3A DSP FPGA Attributes

Device	System Gates	Equivalent Logic Cells	CLB Array (One CLB = Four Slices)				Distributed RAM bits ⁽¹⁾	Block RAM Bits ⁽¹⁾	Dedicated Multipliers	DCMs	Maximum User I/O	Maximum Differential I/O Pairs
			Rows	Columns	Total CLBs	Total Slices						
XA3SD1800A	1800K	37,440	88	48	4,160	16,640	260K	1512K	84	8	519	227
XA3SD3400A	3400K	53,712	104	58	5,968	23,872	373K	2268K	126	8	469	213

Notes:

- By convention, one Kb is equivalent to 1,024 bits.

Refer to [DS610](#), *Spartan-3A DSP FPGA Family Data Sheet* for a full product description, AC and DC specifications, and package pinout descriptions. Any values shown specifically in this XA Spartan-3A DSP Automotive FPGA Family data sheet override those shown in DS610.

For information regarding reliability qualification, refer to RPT103, *Xilinx Spartan-3A Family Automotive Qualification Report* and RPT070, *Spartan-3A Commercial Qualification Report*. Contact your local Xilinx representative for more details on these reports.

Key Feature Differences from Commercial XC Devices

- AEC-Q100 device qualification and full production part approval process (PPAP) documentation support available in both extended temperature I- and Q-Grades
- Guaranteed to meet full electrical specifications over the $T_J = -40^{\circ}\text{C}$ to $+125^{\circ}\text{C}$ temperature range (Q-Grade)
- XA Spartan-3A DSP devices are available in the -4 speed grade only
- PCI-66 and PCI-X are not supported in the XA Spartan-3A DSP FPGA product line
- Platform Flash is not supported within the XA family
- XA Spartan-3A DSP devices are available in Pb-free packaging only
- MultiBoot is not supported in XA versions of this product.
- The XA Spartan-3A DSP device must be power cycled prior to reconfiguration.

Architectural Overview

The XA Spartan-3A DSP family architecture consists of five fundamental programmable functional elements:

- XtremeDSP DSP48A Slice** provides an 18-bit x 18-bit multiplier, 18-bit pre-adder, 48-bit post-adder/accumulator, and cascade capabilities for various DSP applications.
- Configurable Logic Blocks (CLBs)** contain flexible Look-Up Tables (LUTs) that implement logic plus storage elements used as flip-flops or latches. CLBs perform a wide variety of logical functions as well as store data.
- Input/Output Blocks (IOBs)** control the flow of data between the I/O pins and the internal logic of the device. IOBs support bidirectional data flow plus 3-state operation. Supports a variety of signal standards, including several high-performance differential standards. Double Data-Rate (DDR) registers are included.
- Block RAM** provides data storage in the form of 18-Kb dual-port blocks.
- Digital Clock Manager (DCM) Blocks** provide self-calibrating, fully digital solutions for distributing, delaying, multiplying, dividing, and phase-shifting clock signals.

These elements are organized as shown in [Figure 1](#). A dual ring of staggered IOBs surrounds a regular array of CLBs. The XA3SD1800A has four columns of DSP48A slices, and the XA3SD3400A has five columns of DSP48A slices. Each DSP48A has an associated block RAM. The DCMs are positioned in the center with two at the top and two at the bottom of the device and in the two outer columns of the four or five columns of block RAM and DSP48As.

The XA Spartan-3A DSP family features a rich network of routing that interconnect all five functional elements, transmitting signals among them. Each functional element has an associated switch matrix that permits multiple connections to the routing.

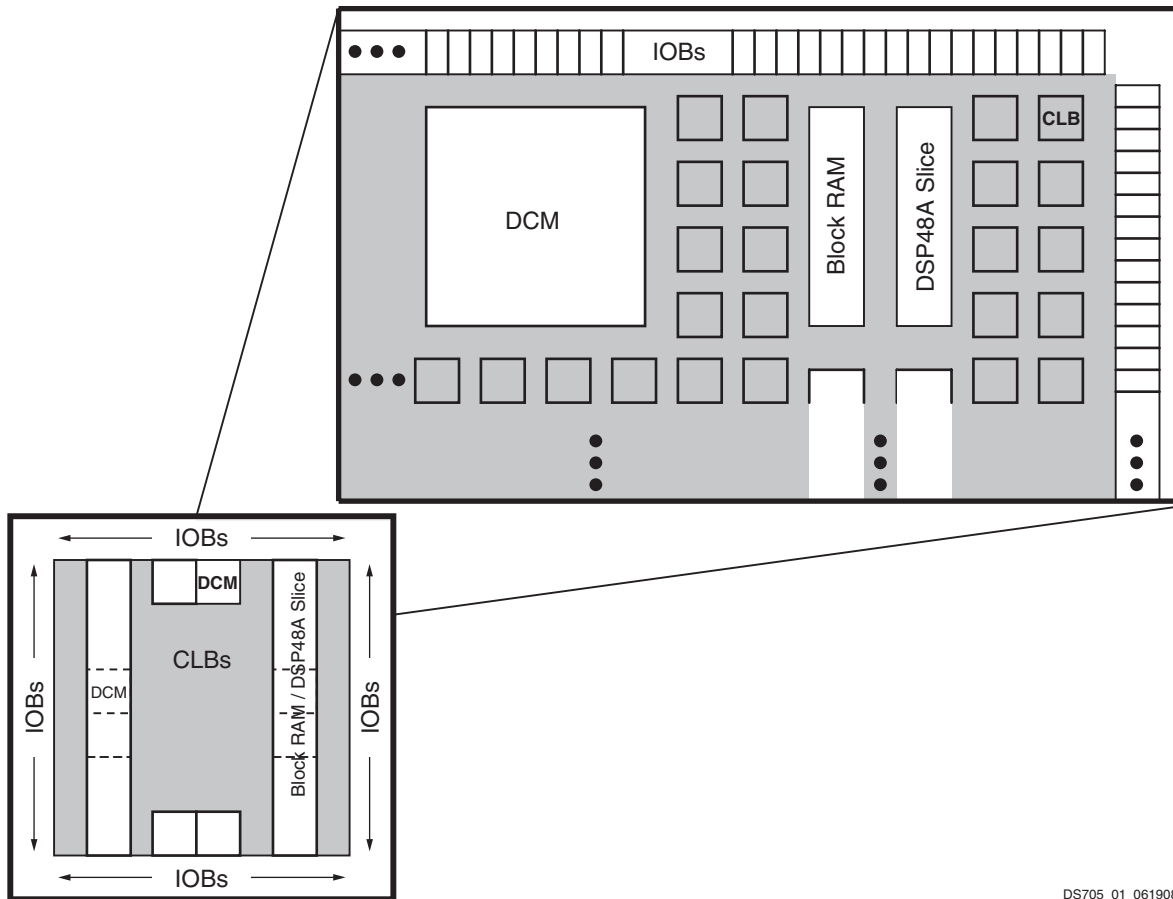

DS705_01_061908

Notes:

1. The XA3SD1800A and XA3SD3400A have two DCMs on both the left and right sides, as well as the two DCMs at the top and bottom of the devices. The two DCMs on the left and right of the chips are in the middle of the outer block RAM/DSP48A columns of the four or five columns in the selected device, as shown in the diagram.
2. A detailed diagram of the DSP48A can be found in [UG431](#), *XtremeDSP DSP48A for Spartan-3A DSP FPGAs User Guide*.

Figure 1: XA Spartan-3A DSP Family Architecture

Configuration

XA Spartan-3A DSP FPGAs are programmed by loading configuration data into robust, reprogrammable, static CMOS configuration latches (CCLs) that collectively control all functional elements and routing resources. The FPGA's configuration data is stored externally in a PROM or some other non-volatile medium, either on or off the board.

After applying power, the configuration data is written to the FPGA using any of five different modes:

- Serial Peripheral Interface (SPI) from an industry-standard SPI serial Flash
- Byte Peripheral Interface (BPI) Up from an industry-standard x8 or x8/x16 parallel NOR Flash
- Slave Serial, typically downloaded from a processor
- Slave Parallel, typically downloaded from a processor
- Boundary-scan (JTAG), typically downloaded from a processor or system tester

Additionally, each XA Spartan-3A DSP FPGA contains a unique, factory-programmed Device DNA identifier useful for tracking purposes, anti-cloning designs, or IP protection.

I/O Capabilities

The XA Spartan-3A DSP FPGA SelectIO interface supports many popular single-ended and differential standards. [Table 2](#) shows the number of user I/Os as well as the number of differential I/O pairs available for each device/package combination. Some of the user I/Os are unidirectional input-only pins as indicated in [Table 2](#).

XA Spartan-3A DSP FPGAs support the following single-ended standards:

- 3.3V low-voltage TTL (LVTTTL)
- Low-voltage CMOS (LVCMOS) at 3.3V, 2.5V, 1.8V, 1.5V, or 1.2V
- 3.3V PCI at 33 MHz
- HSTL I, II, and III at 1.5V and 1.8V, commonly used in memory applications
- SSTL I and II at 1.8V, 2.5V, and 3.3V, commonly used for memory applications

XA Spartan-3A DSP FPGAs support the following differential standards:

- LVDS, mini-LVDS, RSDS, and PPDS I/O at 2.5V or 3.3V
- Bus LVDS I/O at 2.5V
- TMDS I/O at 3.3V
- Differential HSTL and SSTL I/O
- LVPECL inputs at 2.5V or 3.3V

Table 2: Available User I/Os and Differential I/O Pairs

Device	CSG484		FGG676	
	User	Differential	User	Differential
XA3SD1800A	309 <i>(60)</i>	140 <i>(78)</i>	519 <i>(110)</i>	227 <i>(131)</i>
XA3SD3400A	309 <i>(60)</i>	140 <i>(78)</i>	469 <i>(60)</i>	213 <i>(117)</i>

Notes:

1. The number shown in **bold** indicates the maximum number of I/O and input-only pins. The number shown in *(italics)* indicates the number of input-only pins. The differential input-only pin count includes both differential pairs on input-only pins and differential pairs on I/O pins within I/O banks that are restricted to differential inputs.

Production Status

[Table 3](#) indicates the production status of each XA Spartan-3A DSP FPGA by temperature range and speed grade. The table also lists the earliest speed file version required for creating a production configuration bitstream. Later versions are also supported.

Table 3: XA Spartan-3A DSP FPGA Family Production Status (Production Speed File)

Temperature Range		I-Grade	Q-Grade
Speed Grade		Standard (-4)	Standard (-4)
Part Number	XA3SD1800A	Production (v1.32)	Production (v1.32)
	XA3SD3400A	Production (v1.32)	–

Package Marking

Figure 2 shows the top marking for XA Spartan-3A DSP FPGAs in BGA packages.

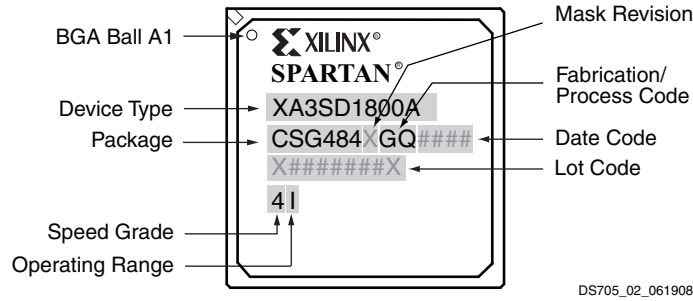

Figure 2: XA Spartan-3A DSP FPGA Package Marking Example

Ordering Information

XA Spartan-3A DSP FPGAs are available in Pb-free packaging only for all device/package combinations.

Pb-Free Packaging

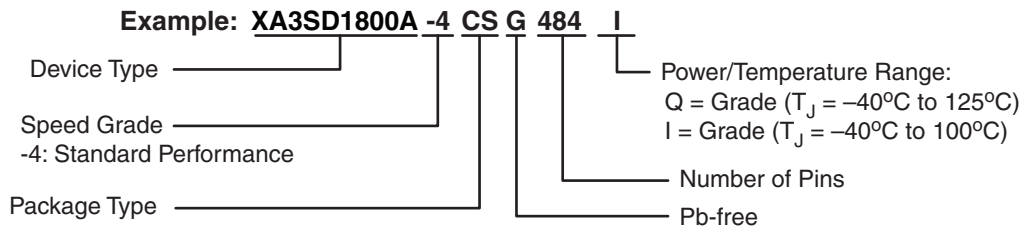

Figure 3: Ordering Information

Device	Speed Grade	Package Type / Number of Pins		Temperature Range (T _J)	
XA3SD1800A	-4 Standard Performance	CSG484	484-ball Chip-Scale Ball Grid Array (CSBGA)	I	I-Grade (-40°C to 100°C)
XA3SD3400A		FGG676	676-ball Fine-Pitch Ball Grid Array (FBGA)	Q	Q-Grade (-40°C to 125°C)

Notes:

1. The XA Spartan-3A DSP FPGA product line is available in -4 speed grade only.
2. The XA3SD3400A is available in I-Grade only.

DC Electrical Characteristics

All parameter limits are representative of worst-case supply voltage and junction temperature conditions. Unless otherwise noted, the published parameter values apply to all XA Spartan-3A DSP devices. AC and DC characteristics are specified using the same numbers for both I-Grade and Q-Grade.

Absolute Maximum Ratings

Stresses beyond those listed under [Table 4](#), *Absolute Maximum Ratings* might cause permanent damage to the device. These are stress ratings only; functional operation of the device at these or any other conditions beyond those listed under the Recommended Operating Conditions is not implied. Exposure to absolute maximum conditions for extended periods of time adversely affects device reliability.

Table 4: Absolute Maximum Ratings

Symbol	Description	Conditions	Min	Max	Units
V_{CCINT}	Internal supply voltage		-0.5	1.32	V
V_{CCAUX}	Auxiliary supply voltage		-0.5	3.75	V
V_{CCO}	Output driver supply voltage		-0.5	3.75	V
V_{REF}	Input reference voltage		-0.5	$V_{CCO} + 0.5$	V
V_{IN}	Voltage applied to all User I/O pins and Dual-Purpose pins	Driver in a high-impedance state	-0.95	4.6	V
	Voltage applied to all Dedicated pins		-0.5	4.6	V
I_{IK}	Input clamp current per I/O pin	$-0.5V < V_{IN} < (V_{CCO} + 0.5V)$ (1)	-	± 100	mA
V_{ESD}	Electrostatic Discharge Voltage	Human body model	-	± 2000	V
		Charged device model	-	± 500	V
		Machine model	-	± 200	V
T_J	Junction temperature		-	125	$^{\circ}C$
T_{STG}	Storage temperature		-65	150	$^{\circ}C$

Notes:

- Upper clamp applies only when using PCI IOSTANDARDS.
- For soldering guidelines, see [UG112: Device Packaging and Thermal Characteristics](#) and [XAPP427: Implementation and Solder Reflow Guidelines for Pb-Free Packages](#).

Power Supply Specifications

Table 5: Supply Voltage Thresholds for Power-On Reset

Symbol	Description	Min	Max	Units
V_{CCINTT}	Threshold for the V_{CCINT} supply	0.4	1.0	V
V_{CCAUXT}	Threshold for the V_{CCAUX} supply	0.8	2.0	V
V_{CCO2T}	Threshold for the V_{CCO} Bank 2 supply	0.8	2.0	V

Notes:

- V_{CCINT} , V_{CCAUX} , and V_{CCO} supplies to the FPGA can be applied in any order. However, the FPGA's configuration source (SPI Flash, parallel NOR Flash, microcontroller) might have specific requirements. Check the data sheet for the attached configuration source. Apply V_{CCINT} last for lowest overall power consumption (see [UG331](#) chapter "Powering Spartan-3 Generation FPGAs" for more information).
- To ensure successful power-on, V_{CCINT} , V_{CCO} Bank 2, and V_{CCAUX} supplies must rise through their respective threshold-voltage ranges with no dips at any point.

Table 6: Supply Voltage Ramp Rate

Symbol	Description	Min	Max	Units
V_{CCINTR}	Ramp rate from GND to valid V_{CCINT} supply level	0.2	100	ms
V_{CCAUXR}	Ramp rate from GND to valid V_{CCAUX} supply level	0.2	100	ms
V_{CCO2R}	Ramp rate from GND to valid V_{CCO} Bank 2 supply level	0.2	100	ms

Notes:

- V_{CCINT} , V_{CCAUX} , and V_{CCO} supplies to the FPGA can be applied in any order. However, the FPGA's configuration source (SPI Flash, parallel NOR Flash, microcontroller) might have specific requirements. Check the data sheet for the attached configuration source. Apply V_{CCINT} last for lowest overall power consumption (see [UG331](#) chapter "Powering Spartan-3 Generation FPGAs" for more information).
- To ensure successful power-on, V_{CCINT} , V_{CCO} Bank 2, and V_{CCAUX} supplies must rise through their respective threshold-voltage ranges with no dips at any point.

Table 7: Supply Voltage Levels Necessary for Preserving CMOS Configuration Latch (CCL) Contents and RAM Data

Symbol	Description	Min	Units
V_{DRINT}	V_{CCINT} level required to retain CMOS Configuration Latch (CCL) and RAM data	1.0	V
V_{DRAUX}	V_{CCAUX} level required to retain CMOS Configuration Latch (CCL) and RAM data	2.0	V

General Recommended Operating Conditions

Table 8: General Recommended Operating Conditions

Symbol	Description		Min	Nominal	Max	Units	
T_J	Junction temperature	I-Grade	-40	–	100	°C	
		Q-Grade	-40	–	125	°C	
V_{CCINT}	Internal supply voltage		1.14	1.20	1.26	V	
$V_{CCO}^{(1)}$	Output driver supply voltage		1.10	–	3.60	V	
V_{CCAUX}	Auxiliary supply voltage ⁽²⁾	$V_{CCAUX} = 2.5$	2.25	2.50	2.75	V	
		$V_{CCAUX} = 3.3$	3.00	3.30	3.60	V	
$V_{IN}^{(3)}$	Input voltage	PCI™ IOSTANDARD		-0.5	–	$V_{CCO}+0.5$	V
		All other IOSTANDARDS	IP or IO_#	-0.5	–	4.10	V
			IO_Lxy_# ⁽⁴⁾	-0.5	–	4.10	V
T_{IN}	Input signal transition time ⁽⁵⁾		–	–	500	ns	

Notes:

1. This V_{CCO} range spans the lowest and highest operating voltages for all supported I/O standards. [Table 11](#) lists the recommended V_{CCO} range specific to each of the single-ended I/O standards, and [Table 13](#) lists that specific to the differential standards.
2. Define V_{CCAUX} selection using CONFIG VCCAUX constraint.
3. See [XAPP459](#), *Eliminating I/O Coupling Effects when Interfacing Large-Swing Single-Ended Signals to User I/O Pins on Spartan-3 Generation FPGAs*.
4. For single-ended signals that are placed on a differential-capable I/O, V_{IN} of -0.2V to -0.5V is supported but can cause increased leakage between the two pins. See *Parasitic Leakage* in [UG331](#), *Spartan-3 Generation FPGA User Guide*.
5. Measured between 10% and 90% V_{CCO} . Follow [Signal Integrity](#) recommendations.

General DC Characteristics for I/O Pins

Table 9: General DC Characteristics of User I/O, Dual-Purpose, and Dedicated Pins ⁽¹⁾

Symbol	Description	Test Conditions		Min	Typ	Max	Units
$I_L^{(2)}$	Leakage current at User I/O, Input-only, Dual-Purpose, and Dedicated pins, FPGA powered	Driver is in a high-impedance state, $V_{IN} = 0V$ or V_{CCO} max, sample-tested		-10	-	+10	μA
I_{HS}	Leakage current on pins during hot socketing, FPGA unpowered	All pins except INIT_B, PROG_B, DONE, and JTAG pins when PUDC_B = 1.		-10	-	+10	μA
		INIT_B, PROG_B, DONE, and JTAG pins or other pins when PUDC_B = 0.		Add $I_{HS} + I_{RPU}$		μA	
$I_{RPU}^{(3)}$	Current through pull-up resistor at User I/O, Dual-Purpose, Input-only, and Dedicated pins. Dedicated pins are powered by V_{CCAUX} .	$V_{IN} = GND$	V_{CCO} or $V_{CCAUX} = 3.0V$ to $3.6V$	-151	-315	-710	μA
			V_{CCO} or $V_{CCAUX} = 2.3V$ to $2.7V$	-82	-182	-437	μA
			$V_{CCO} = 1.7V$ to $1.9V$	-36	-88	-226	μA
			$V_{CCO} = 1.4V$ to $1.6V$	-22	-56	-148	μA
			$V_{CCO} = 1.14V$ to $1.26V$	-11	-31	-83	μA
$R_{PU}^{(3)}$	Equivalent pull-up resistor value at User I/O, Dual-Purpose, Input-only, and Dedicated pins (based on I_{RPU} per Note 3)	$V_{IN} = GND$	$V_{CCO} = 3.0V$ to $3.6V$	5.1	11.4	23.9	$k\Omega$
			$V_{CCO} = 2.3V$ to $2.7V$	6.2	14.8	33.1	$k\Omega$
			$V_{CCO} = 1.7V$ to $1.9V$	8.4	21.6	52.6	$k\Omega$
			$V_{CCO} = 1.4V$ to $1.6V$	10.8	28.4	74.0	$k\Omega$
			$V_{CCO} = 1.14V$ to $1.26V$	15.3	41.1	119.4	$k\Omega$
$I_{RPD}^{(3)}$	Current through pull-down resistor at User I/O, Dual-Purpose, Input-only, and Dedicated pins	$V_{IN} = V_{CCO}$	$V_{CCAUX} = 3.0V$ to $3.6V$	167	346	659	μA
			$V_{CCAUX} = 2.25V$ to $2.75V$	100	225	457	μA
$R_{PD}^{(3)}$	Equivalent pull-down resistor value at User I/O, Dual-Purpose, Input-only, and Dedicated pins (based on I_{RPD} per Note 3)	$V_{CCAUX} = 3.0V$ to $3.6V$	$V_{IN} = 3.0V$ to $3.6V$	5.5	10.4	20.8	$k\Omega$
			$V_{IN} = 2.3V$ to $2.7V$	4.1	7.8	15.7	$k\Omega$
			$V_{IN} = 1.7V$ to $1.9V$	3.0	5.7	11.1	$k\Omega$
			$V_{IN} = 1.4V$ to $1.6V$	2.7	5.1	9.6	$k\Omega$
			$V_{IN} = 1.14V$ to $1.26V$	2.4	4.5	8.1	$k\Omega$
		$V_{CCAUX} = 2.25V$ to $2.75V$	$V_{IN} = 3.0V$ to $3.6V$	7.9	16.0	35.0	$k\Omega$
			$V_{IN} = 2.3V$ to $2.7V$	5.9	12.0	26.3	$k\Omega$
			$V_{IN} = 1.7V$ to $1.9V$	4.2	8.5	18.6	$k\Omega$
			$V_{IN} = 1.4V$ to $1.6V$	3.6	7.2	15.7	$k\Omega$
			$V_{IN} = 1.14V$ to $1.26V$	3.0	6.0	12.5	$k\Omega$
I_{REF}	V_{REF} current per pin	All V_{CCO} levels		-10	-	+10	μA
C_{IN}	Input capacitance	-		-	-	10	pF
R_{DT}	Resistance of optional differential termination circuit within a differential I/O pair. Not available on Input-only pairs.	$V_{CCO} = 3.3V \pm 10\%$	LVDS_33, MINI_LVDS_33, RSDS_33	90	100	115	Ω
		$V_{CCO} = 2.5V \pm 10\%$	LVDS_25, MINI_LVDS_25, RSDS_25	90	110	-	Ω

Notes:

1. The numbers in this table are based on the conditions set forth in Table 8.
2. For single-ended signals that are placed on a differential-capable I/O, V_{IN} of $-0.2V$ to $-0.5V$ is supported but can cause increased leakage between the two pins. See *Parasitic Leakage* in [UG331, Spartan-3 Generation FPGA User Guide](#).
3. This parameter is based on characterization. The pull-up resistance $R_{PU} = V_{CCO} / I_{RPU}$. The pull-down resistance $R_{PD} = V_{IN} / I_{RPD}$.

Quiescent Current Requirements

Table 10: Quiescent Supply Current Characteristics

Symbol	Description	Device	Typical ⁽²⁾	I-Grade Maximum ⁽²⁾	Q-Grade Maximum ⁽²⁾	Units
I _{CCINTQ}	Quiescent V _{CCINT} supply current	XA3SD1800A	41	500	900	mA
		XA3SD3400A	64	725	–	mA
I _{CCOQ}	Quiescent V _{CCO} supply current	XA3SD1800A	0.4	5	5	mA
		XA3SD3400A	0.4	5	–	mA
I _{CCAUXQ}	Quiescent V _{CCAUX} supply current	XA3SD1800A	25	110	145	mA
		XA3SD3400A	39	160	–	mA

Notes:

- The numbers in this table are based on the conditions set forth in [Table 8](#).
- Quiescent supply current is measured with all I/O drivers in a high-impedance state and with all pull-up/pull-down resistors at the I/O pads disabled. Typical values are characterized using typical devices at room temperature (T_J of 25°C at V_{CCINT} = 1.2V, V_{CCO} = 3.3V, and V_{CCAUX} = 2.5V). The maximum limits are tested for each device at the respective maximum specified junction temperature and at maximum voltage limits with V_{CCINT} = 1.26V, V_{CCO} = 3.6V, and V_{CCAUX} = 3.6V. The FPGA is programmed with a “blank” configuration data file (that is, a design with no functional elements instantiated). For conditions other than those described above (for example, a design including functional elements), measured quiescent current levels will be different than the values in the table.
- There are two recommended ways to estimate the total power consumption (quiescent plus dynamic) for a specific design: a) The [Spartan-3A DSP FPGA XPower Estimator](#) provides quick, approximate, typical estimates, and does not require a netlist of the design. b) XPower Analyzer uses a netlist as input to provide maximum estimates as well as more accurate typical estimates.
- The maximum numbers in this table indicate the minimum current each power rail requires in order for the FPGA to power-on successfully.
- For information on the power-saving Suspend mode, see [XAPP480, Using Suspend Mode in Spartan-3 Generation FPGAs](#). Suspend mode typically saves 40% total power consumption compared to quiescent current.

Single-Ended I/O Standards

Table 11: Recommended Operating Conditions for User I/Os Using Single-Ended Standards

IOSTANDARD Attribute	V _{CCO} for Drivers ⁽²⁾			V _{REF}			V _{IL}	V _{IH} ⁽³⁾
	Min (V)	Nom (V)	Max (V)	Min (V)	Nom (V)	Max (V)	Max (V)	Min (V)
LVTTL	3.0	3.3	3.6	V _{REF} is not used for these I/O standards			0.8	2.0
LVC MOS33 ⁽⁴⁾	3.0	3.3	3.6				0.8	2.0
LVC MOS25 ^(4,5)	2.3	2.5	2.7				0.7	1.7
LVC MOS18	1.65	1.8	1.95				0.4	0.8
LVC MOS15	1.4	1.5	1.6				0.4	0.8
LVC MOS12	1.1	1.2	1.3				0.4	0.7
PCI33_3 ⁽⁶⁾	3.0	3.3	3.6				0.3 • V _{CCO}	0.5 • V _{CCO}
HSTL_I	1.4	1.5	1.6	0.68	0.75	0.9	V _{REF} - 0.1	V _{REF} + 0.1
HSTL_III	1.4	1.5	1.6	-	0.9	-	V _{REF} - 0.1	V _{REF} + 0.1
HSTL_I_18	1.7	1.8	1.9	0.8	0.9	1.1	V _{REF} - 0.1	V _{REF} + 0.1
HSTL_II_18	1.7	1.8	1.9	-	0.9	-	V _{REF} - 0.1	V _{REF} + 0.1
HSTL_III_18	1.7	1.8	1.9	-	1.1	-	V _{REF} - 0.1	V _{REF} + 0.1
SSTL18_I	1.7	1.8	1.9	0.833	0.900	0.969	V _{REF} - 0.125	V _{REF} + 0.125
SSTL18_II	1.7	1.8	1.9	0.833	0.900	0.969	V _{REF} - 0.125	V _{REF} + 0.125
SSTL2_I	2.3	2.5	2.7	1.15	1.25	1.38	V _{REF} - 0.150	V _{REF} + 0.150
SSTL2_II	2.3	2.5	2.7	1.15	1.25	1.38	V _{REF} - 0.150	V _{REF} + 0.150
SSTL3_I	3.0	3.3	3.6	1.3	1.5	1.7	V _{REF} - 0.2	V _{REF} + 0.2
SSTL3_II	3.0	3.3	3.6	1.3	1.5	1.7	V _{REF} - 0.2	V _{REF} + 0.2

Notes:

- Descriptions of the symbols used in this table are as follows:
V_{CCO} – the supply voltage for output drivers
V_{REF} – the reference voltage for setting the input switching threshold
V_{IL} – the input voltage that indicates a Low logic level
V_{IH} – the input voltage that indicates a High logic level
- In general, the V_{CCO} rails supply only output drivers, not input circuits. The exceptions are for LVC MOS25 inputs when V_{CCAUX} = 3.3V range and for PCI I/O standards.
- For device operation, the maximum signal voltage (V_{IH} max) can be as high as V_{IN} max. See Table 4.
- There is approximately 100 mV of hysteresis on inputs using LVC MOS33 and LVC MOS25 I/O standards.
- All Dedicated pins (PROG_B, DONE, SUSPEND, TCK, TDI, TDO, and TMS) draw power from the V_{CCAUX} rail and use the LVC MOS25 or LVC MOS33 standard depending on V_{CCAUX}. The Dual-Purpose configuration pins use the LVC MOS25 standard before the User mode. When using these pins as part of a standard 2.5V configuration interface, apply 2.5V to the V_{CCO} lines of Banks 0, 1, and 2 at power-on as well as throughout configuration.
- For information on PCI IP solutions, see www.xilinx.com/pci. The PCI IOSTANDARD is not supported on input-only pins.

Table 12: DC Characteristics of User I/Os Using Single-Ended Standards

IOSTANDARD Attribute		Test Conditions		Logic Level Characteristics	
		I _{OL} (mA)	I _{OH} (mA)	V _{OL} Max (V)	V _{OH} Min (V)
LVTTTL ⁽³⁾	2	2	-2	0.4	2.4
	4	4	-4		
	6	6	-6		
	8	8	-8		
	12	12	-12		
	16	16	-16		
	24	24 ⁽⁶⁾	-24		
LVCMOS33 ⁽³⁾	2	2	-2	0.4	V _{CCO} - 0.4
	4	4	-4		
	6	6	-6		
	8	8	-8		
	12	12	-12		
	16	16	-16 ⁽⁶⁾		
	24 ⁽⁴⁾	24	-24 ⁽⁶⁾		
LVCMOS25 ⁽³⁾	2	2	-2	0.4	V _{CCO} - 0.4
	4	4	-4		
	6	6	-6		
	8	8	-8		
	12	12	-12		
	16 ⁽⁴⁾	16	-16 ⁽⁶⁾		
	24 ⁽⁴⁾	24 ⁽⁶⁾	-24 ⁽⁶⁾		
LVCMOS18 ⁽³⁾	2	2	-2	0.4	V _{CCO} - 0.4
	4	4	-4		
	6	6	-6 ⁽⁶⁾		
	8	8	-8		
	12 ⁽⁴⁾	12	-12 ⁽⁶⁾		
	16 ⁽⁴⁾	16	-16		
LVCMOS15 ⁽³⁾	2	2	-2	0.4	V _{CCO} - 0.4
	4	4	-4		
	6	6	-6		
	8 ⁽⁴⁾	8	-8		
	12 ⁽⁴⁾	12	-12		
LVCMOS12 ⁽³⁾	2	2	-2	0.4	V _{CCO} - 0.4
	4 ⁽⁴⁾	4	-4		
	6 ⁽⁴⁾	6	-6		
PCI33_3 ⁽⁵⁾		1.5	-0.5	10% V _{CCO}	90% V _{CCO}

Table 12: DC Characteristics of User I/Os Using Single-Ended Standards (Cont'd)

IOSTANDARD Attribute	Test Conditions		Logic Level Characteristics	
	I _{OL} (mA)	I _{OH} (mA)	V _{OL} Max (V)	V _{OH} Min (V)
HSTL_I ⁽⁴⁾	8	-8	0.4	V _{CCO} - 0.4
HSTL_III ⁽⁴⁾	24 ⁽⁷⁾	-8	0.4	V _{CCO} - 0.4
HSTL_I_18	8	-8	0.4	V _{CCO} - 0.4
HSTL_II_18 ⁽⁴⁾	16	-16 ⁽⁷⁾	0.4	V _{CCO} - 0.4
HSTL_III_18	24 ⁽⁷⁾	-8	0.4	V _{CCO} - 0.4
SSTL18_I	6.7	-6.7	V _{TT} - 0.475	V _{TT} + 0.475
SSTL18_II ⁽⁴⁾	13.4	-13.4	V _{TT} - 0.475	V _{TT} + 0.475
SSTL2_I	8.1	-8.1	V _{TT} - 0.61	V _{TT} + 0.61
SSTL2_II ⁽⁴⁾	16.2	-16.2	V _{TT} - 0.80	V _{TT} + 0.80
SSTL3_I	8	-8	V _{TT} - 0.6	V _{TT} + 0.6
SSTL3_II	16	-16	V _{TT} - 0.8	V _{TT} + 0.8

Notes:

- The numbers in this table are based on the conditions set forth in Table 8 and Table 11.
- Descriptions of the symbols used in this table are as follows:
 I_{OL} – the output current condition under which V_{OL} is tested
 I_{OH} – the output current condition under which V_{OH} is tested
 V_{OL} – the output voltage that indicates a Low logic level
 V_{OH} – the output voltage that indicates a High logic level
 V_{IL} – the input voltage that indicates a Low logic level
 V_{IH} – the input voltage that indicates a High logic level
 V_{CCO} – the supply voltage for output drivers
 V_{REF} – the reference voltage for setting the input switching threshold
 V_{TT} – the voltage applied to a resistor termination
- For the LVCMOS and LVTTL standards: the same V_{OL} and V_{OH} limits apply for both the Fast and Slow slew attributes.
- These higher-drive output standards are supported only on FPGA banks 1 and 3. Inputs are unrestricted. See the chapter "Using I/O Resources" in UG331.
- Tested according to the relevant PCI specifications. For information on PCI IP solutions, see http://www.xilinx.com/products/design_resources/conn_central/protocols/pci_pcix.htm. The PCI IOSTANDARD is not supported on input-only pins. The PCIX IOSTANDARD is available and has equivalent characteristics, but no PCI-X IP is supported.
- Derate by 20% for T_J above 100°C
- Derate by 5% for T_J above 100°C

Differential I/O Standards

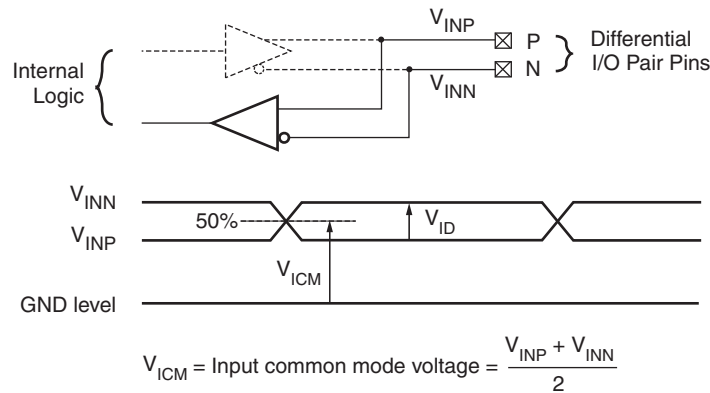

DS705_04_041111

Figure 4: Differential Input Voltages

Table 13: Recommended Operating Conditions for User I/Os Using Differential Signal Standards

IOSTANDARD Attribute	V _{CCO} for Drivers ⁽¹⁾			V _{ID}			V _{ICM} ⁽²⁾		
	Min (V)	Nom (V)	Max (V)	Min (mV)	Nom (mV)	Max (mV)	Min (V)	Nom (V)	Max (V)
LVDS_25 ⁽³⁾	2.25	2.5	2.75	100	350	600	0.3	1.25	2.35
LVDS_33 ⁽³⁾	3.0	3.3	3.6	100	350	600	0.3	1.25	2.35
BLVDS_25 ⁽⁴⁾	2.25	2.5	2.75	100	300	–	0.3	1.3	2.35
MINI_LVDS_25 ⁽³⁾	2.25	2.5	2.75	200	–	600	0.3	1.2	1.95
MINI_LVDS_33 ⁽³⁾	3.0	3.3	3.6	200	–	600	0.3	1.2	1.95
LVPECL_25 ⁽⁵⁾	Inputs Only			100	800	1000	0.3	1.2	1.95
LVPECL_33 ⁽⁵⁾	Inputs Only			100	800	1000	0.3	1.2	2.8 ⁽⁶⁾
RSDS_25 ⁽³⁾	2.25	2.5	2.75	100	200	–	0.3	1.2	1.5
RSDS_33 ⁽³⁾	3.0	3.3	3.6	100	200	–	0.3	1.2	1.5
TMDS_33 ^(3,4,7)	3.14	3.3	3.47	150	–	1200	2.7	–	3.23
PPDS_25 ⁽³⁾	2.25	2.5	2.75	100	–	400	0.2	–	2.3
PPDS_33 ⁽³⁾	3.0	3.3	3.6	100	–	400	0.2	–	2.3
DIFF_HSTL_I_18	1.7	1.8	1.9	100	–	–	0.8	–	1.1
DIFF_HSTL_II_18 ⁽⁸⁾	1.7	1.8	1.9	100	–	–	0.8	–	1.1
DIFF_HSTL_III_18	1.7	1.8	1.9	100	–	–	0.8	–	1.1
DIFF_HSTL_I	1.4	1.5	1.6	100	–	–	0.68	–	0.9
DIFF_HSTL_III	1.4	1.5	1.6	100	–	–	–	0.9	–
DIFF_SSTL18_I	1.7	1.8	1.9	100	–	–	0.7	–	1.1
DIFF_SSTL18_II ⁽⁸⁾	1.7	1.8	1.9	100	–	–	0.7	–	1.1
DIFF_SSTL2_I	2.3	2.5	2.7	100	–	–	1.0	–	1.5
DIFF_SSTL2_II ⁽⁸⁾	2.3	2.5	2.7	100	–	–	1.0	–	1.5
DIFF_SSTL3_I	3.0	3.3	3.6	100	–	–	1.1	–	1.9
DIFF_SSTL3_II	3.0	3.3	3.6	100	–	–	1.1	–	1.9

Notes:

1. The V_{CCO} rails supply only differential output drivers, not input circuits.
2. V_{ICM} must be less than V_{CCAUX}.
3. These true differential output standards are supported only on FPGA banks 0 and 2. Inputs are unrestricted. See the chapter "Using I/O Resources" in [UG331](#).
4. See [External Termination Requirements for Differential I/O](#), page 16.
5. LVPECL is supported on inputs only, not outputs. LVPECL_33 requires V_{CCAUX} = 3.3V ± 10%.
6. LVPECL_33 maximum V_{ICM} = the lower of 2.8V or V_{CCAUX} – (V_{ID}/2).
7. Requires V_{CCAUX} = 3.3V ± 10% for inputs. (V_{CCAUX} – 300 mV) ≤ V_{ICM} ≤ (V_{CCAUX} – 37 mV)
8. These higher-drive output standards are supported only on FPGA banks 1 and 3. Inputs are unrestricted. See the chapter "Using I/O Resources" in [UG331](#).
9. V_{REF} inputs are used for the DIFF_SSTL and DIFF_HSTL standards. The V_{REF} settings are the same as for the single-ended versions in [Table 11](#). Other differential standards do not use V_{REF}.

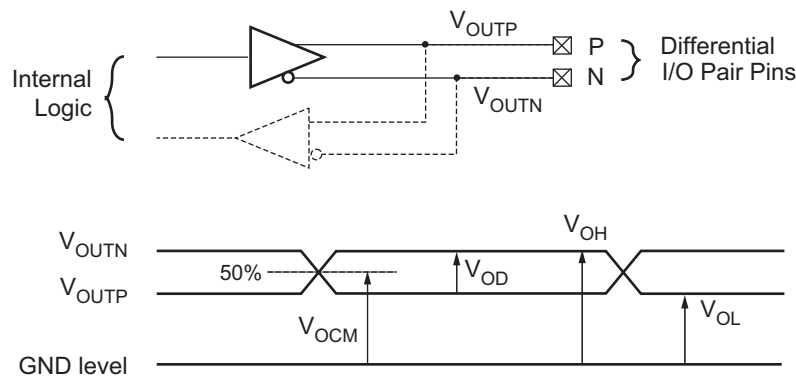

$$V_{OCM} = \text{Output common mode voltage} = \frac{V_{OUTP} + V_{OUTN}}{2}$$

$$V_{OD} = \text{Output differential voltage} = |V_{OUTP} - V_{OUTN}|$$

V_{OH} = Output voltage indicating a High logic level

V_{OL} = Output voltage indicating a Low logic level

DS705_05_041111

Figure 5: Differential Output Voltages

Table 14: DC Characteristics of User I/Os Using Differential Signal Standards

IOSTANDARD Attribute	V_{OD}			V_{OCM}			V_{OH}	V_{OL}
	Min (mV)	Typ (mV)	Max (mV)	Min (V)	Typ (V)	Max (V)	Min (V)	Max (V)
LVDS_25	247	350	454	1.125	–	1.375	–	–
LVDS_33	247	350	454	1.125	–	1.375	–	–
BLVDS_25	240	350	460	–	1.30	–	–	–
MINI_LVDS_25	300	–	600	1.0	–	1.4	–	–
MINI_LVDS_33	300	–	600	1.0	–	1.4	–	–
RSDS_25	100	–	400	1.0	–	1.4	–	–
RSDS_33	100	–	400	1.0	–	1.4	–	–
TMDS_33	400	–	800	$V_{CCO} - 0.405$	–	$V_{CCO} - 0.190$	–	–
PPDS_25	100	–	400	0.5	0.8	1.4	–	–
PPDS_33	100	–	400	0.5	0.8	1.4	–	–
DIFF_HSTL_I_18	–	–	–	–	–	–	$V_{CCO} - 0.4$	0.4
DIFF_HSTL_II_18	–	–	–	–	–	–	$V_{CCO} - 0.4$	0.4
DIFF_HSTL_III_18	–	–	–	–	–	–	$V_{CCO} - 0.4$	0.4
DIFF_HSTL_I	–	–	–	–	–	–	$V_{CCO} - 0.4$	0.4
DIFF_HSTL_III	–	–	–	–	–	–	$V_{CCO} - 0.4$	0.4
DIFF_SSTL18_I	–	–	–	–	–	–	$V_{TT} + 0.475$	$V_{TT} - 0.475$
DIFF_SSTL18_II	–	–	–	–	–	–	$V_{TT} + 0.475$	$V_{TT} - 0.475$
DIFF_SSTL2_I	–	–	–	–	–	–	$V_{TT} + 0.61$	$V_{TT} - 0.61$
DIFF_SSTL2_II	–	–	–	–	–	–	$V_{TT} + 0.81$	$V_{TT} - 0.81$
DIFF_SSTL3_I	–	–	–	–	–	–	$V_{TT} + 0.6$	$V_{TT} - 0.6$
DIFF_SSTL3_II	–	–	–	–	–	–	$V_{TT} + 0.8$	$V_{TT} - 0.8$

Notes:

1. The numbers in this table are based on the conditions set forth in Table 8 and Table 13.
2. See External Termination Requirements for Differential I/O, page 16.
3. Output voltage measurements for all differential standards are made with a termination resistor (R_T) of 100 Ω across the N and P pins of the differential signal pair.
4. At any given time, no more than two of the following differential output standards can be assigned to an I/O bank: LVDS_25, RSDS_25, MINI_LVDS_25, PPDS_25 when $V_{CCO}=2.5V$, or LVDS_33, RSDS_33, MINI_LVDS_33, TMDS_33, PPDS_33 when $V_{CCO} = 3.3V$.

External Termination Requirements for Differential I/O

LVDS, RSDS, MINI_LVDS, and PPDS I/O Standards

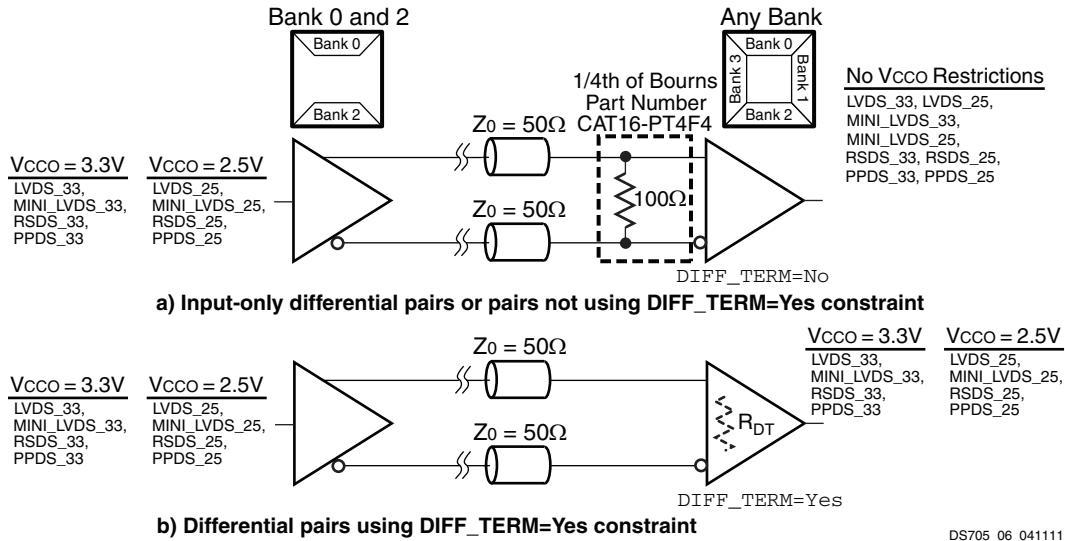

Figure 6: External Input Termination for LVDS, RSDS, MINI_LVDS, and PPDS I/O Standards

BLVDS_25 I/O Standard

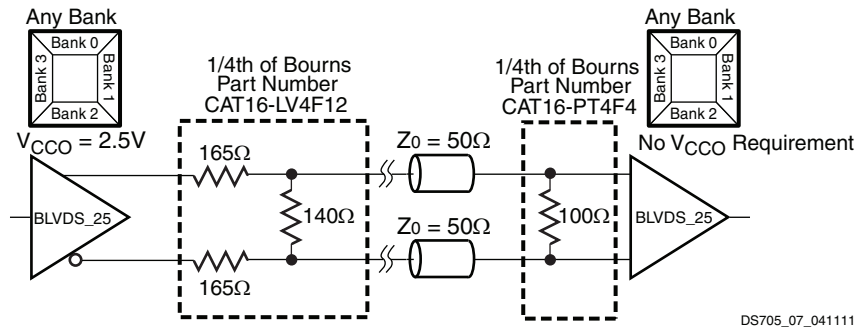

Figure 7: External Output and Input Termination Resistors for BLVDS_25 I/O Standard

TMDS_33 I/O Standard

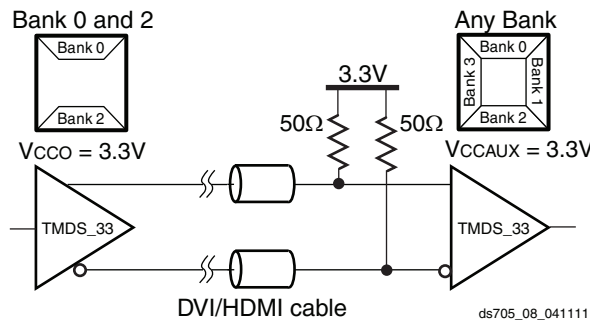

Figure 8: External Input Resistors Required for TMDS_33 I/O Standard

Device DNA Read Endurance

Table 15: Device DNA Identifier Memory Characteristics

Symbol	Description	Minimum	Units
DNA_CYCLES	Number of READ operations or JTAG ISC_DNA read operations. Unaffected by HOLD or SHIFT operations.	30,000,000	Read cycles

Switching Characteristics

All XA Spartan-3A DSP FPGAs ship in the -4 speed grade. Switching characteristics in this document are designated as Production, as shown in Table 16.

Production: These specifications are approved once enough production silicon of a particular device family member has been characterized to provide full correlation between speed files and devices over numerous production lots. There is no under-reporting of delays, and customers receive formal notification of any subsequent changes.

Software Version Requirements

Production-quality systems must use FPGA designs compiled using a speed file designated as PRODUCTION status. FPGAs designs using a less mature speed file designation should only be used during system prototyping or pre-production qualification. FPGA designs with speed files designated as Preview, Advance, or Preliminary should not be used in a production-quality system.

Whenever a speed file designation changes, as a device matures toward Production status, rerun the latest Xilinx ISE software on the FPGA design to ensure that the FPGA design incorporates the latest timing information and software updates.

All parameter limits are representative of worst-case supply voltage and junction temperature conditions. Unless otherwise noted, the published parameter values apply to all XA Spartan-3A DSP devices. AC and DC characteristics are specified using the same numbers for both I-Grade and Q-Grade.

Create a Xilinx user account and sign up to receive automatic e-mail notification whenever this data sheet or the associated user guides are updated.

- Sign Up for Alerts on Xilinx.com
<http://www.xilinx.com/support/answers/18683.htm>

Timing parameters and their representative values are selected for inclusion below either because they are important as general design requirements or they indicate fundamental device performance characteristics. The XA Spartan-3A DSP FPGA speed files (v1.32), part of the Xilinx Development Software, are the original source for many but not all of the values. The speed grade designations for these files are shown in Table 16. For more complete, more precise, and worst-case data, use the values reported by the Xilinx static timing analyzer (TRACE in the Xilinx development software) and back-annotated to the simulation netlist.

Table 16: XA Spartan-3A DSP FPGA v1.32 Speed Grade Designations

Device	Production
XA3SD1800A	-4
XA3SD3400A	-4

Table 17 provides the recent history of the XA Spartan-3A DSP FPGA speed files.

Table 17: XA Spartan-3A DSP Speed File Version History

Version	ISE Software Release	Description
1.32	ISE 10.1 SP2	Support for Automotive.

I/O Timing

Pin-to-Pin Clock-to-Output Times

Table 18: Pin-to-Pin Clock-to-Output Times for the IOB Output Path

Symbol	Description	Conditions	Device	Speed Grade: -4	Units
				Max	
Clock-to-Output Times					
T _{ICKOFDCM}	When reading from the Output Flip-Flop (OFF), the time from the active transition on the Global Clock pin to data appearing at the Output pin. The DCM is in use.	LVCMOS25 ⁽²⁾ , 12mA output drive, Fast slew rate, with DCM ⁽³⁾	XA3SD1800A	3.51	ns
			XA3SD3400A	3.82	ns
T _{ICKOF}	When reading from OFF, the time from the active transition on the Global Clock pin to data appearing at the Output pin. The DCM is not in use.	LVCMOS25 ⁽²⁾ , 12mA output drive, Fast slew rate, without DCM	XA3SD1800A	5.58	ns
			XA3SD3400A	6.13	ns

Notes:

1. The numbers in this table are tested using the methodology presented in Table 27 and are based on the operating conditions set forth in Table 8 and Table 11.
2. This clock-to-output time requires adjustment whenever a signal standard other than LVCMOS25 is assigned to the Global Clock Input or a standard other than LVCMOS25 with 12 mA drive and Fast slew rate is assigned to the data Output. If the former is true, add the appropriate Input adjustment from Table 23. If the latter is true, add the appropriate Output adjustment from Table 26.
3. DCM output jitter is included in all measurements.

Pin-to-Pin Setup and Hold Times

Table 19: Pin-to-Pin Setup and Hold Times for the IOB Input Path (System Synchronous)

Symbol	Description	Conditions	Device	Speed Grade: -4	Units
				Min	
Setup Times					
T _{PSDCM}	When writing to the Input Flip-Flop (IFF), the time from the setup of data at the Input pin to the active transition at a Global Clock pin. The DCM is in use. No Input Delay is programmed.	LVCMOS25 ⁽²⁾ , IFD_DELAY_VALUE = 0, with DCM ⁽⁴⁾	XA3SD1800A	3.11	ns
			XA3SD3400A	2.49	ns
T _{PSFD}	When writing to IFF, the time from the setup of data at the Input pin to an active transition at the Global Clock pin. The DCM is not in use. The Input Delay is programmed.	LVCMOS25 ⁽²⁾ , IFD_DELAY_VALUE = 6, without DCM	XA3SD1800A	3.39	ns
			XA3SD3400A	3.08	ns
Hold Times					
T _{PHDCM}	When writing to IFF, the time from the active transition at the Global Clock pin to the point when data must be held at the Input pin. The DCM is in use. No Input Delay is programmed.	LVCMOS25 ⁽³⁾ , IFD_DELAY_VALUE = 0, with DCM ⁽⁴⁾	XA3SD1800A	-0.38	ns
			XA3SD3400A	-0.26	ns
T _{PHFD}	When writing to IFF, the time from the active transition at the Global Clock pin to the point when data must be held at the Input pin. The DCM is not in use. The Input Delay is programmed.	LVCMOS25 ⁽³⁾ , IFD_DELAY_VALUE = 6, without DCM	XA3SD1800A	-0.71	ns
			XA3SD3400A	-0.65	ns

Notes:

1. The numbers in this table are tested using the methodology presented in Table 27 and are based on the operating conditions set forth in Table 8 and Table 11.
2. This setup time requires adjustment whenever a signal standard other than LVCMOS25 is assigned to the Global Clock Input or the data Input. If this is true of the Global Clock Input, subtract the appropriate adjustment from Table 23. If this is true of the data Input, add the appropriate Input adjustment from the same table.
3. This hold time requires adjustment whenever a signal standard other than LVCMOS25 is assigned to the Global Clock Input or the data Input. If this is true of the Global Clock Input, add the appropriate Input adjustment from Table 23. If this is true of the data Input, subtract the appropriate Input adjustment from the same table. When the hold time is negative, it is possible to change the data before the clock's active edge.
4. DCM output jitter is included in all measurements.

Input Setup and Hold Times

Table 20: Setup and Hold Times for the IOB Input Path

Symbol	Description	Conditions	IFD_DELAY_VALUE	Device	Speed Grade: -4	Units
					Min	
Setup Times						
T _{IOPICK}	Time from the setup of data at the Input pin to the active transition at the ICLK input of the Input Flip-Flop (IFF). No Input Delay is programmed.	LVCMOS25 ⁽²⁾	0	XA3SD1800A	1.81	ns
				XA3SD3400A	1.88	ns
T _{IOPICKD}	Time from the setup of data at the Input pin to the active transition at the ICLK input of the Input Flip-Flop (IFF). The Input Delay is programmed.	LVCMOS25 ⁽²⁾	1	XA3SD1800A	2.24	ns
					2.83	ns
					3.64	ns
					4.20	ns
					4.16	ns
					5.09	ns
					6.02	ns
					6.63	ns
			2	XA3SD3400A	2.44	ns
					3.02	ns
					3.81	ns
					4.39	ns
					4.26	ns
					5.08	ns
					5.95	ns
					6.55	ns

Table 20: Setup and Hold Times for the IOB Input Path (Cont'd)

Symbol	Description	Conditions	IFD_DELAY_VALUE	Device	Speed Grade: -4	Units				
					Min					
Hold Times										
T _{IOICKP}	Time from the active transition at the ICLK input of the Input Flip-Flop (IFF) to the point where data must be held at the Input pin. No Input Delay is programmed.	LVCMOS25 ⁽³⁾	0	XA3SD1800A	-0.52	ns				
				XA3SD3400A	-0.56	ns				
T _{IOICKPD}	Time from the active transition at the ICLK input of the Input Flip-Flop (IFF) to the point where data must be held at the Input pin. The Input Delay is programmed.	LVCMOS25 ⁽³⁾	1	XA3SD1800A	-1.40	ns				
					-2.11	ns				
					-2.48	ns				
					-2.77	ns				
					-2.62	ns				
					-3.06	ns				
					-3.42	ns				
					-3.65	ns				
				XA3SD3400A	-1.31	ns				
					-1.88	ns				
					-2.44	ns				
					-2.89	ns				
					-2.83	ns				
					-3.33	ns				
					-3.63	ns				
					-3.96	ns				
				Set/Reset Pulse Width						
				T _{RPW_IOB}	Minimum pulse width to SR control input on IOB	-	-	All	1.61	ns

Notes:

1. The numbers in this table are tested using the methodology presented in Table 27 and are based on the operating conditions set forth in Table 8 and Table 11.
2. This setup time requires adjustment whenever a signal standard other than LVCMOS25 is assigned to the data Input. If this is true, add the appropriate Input adjustment from Table 23.
3. These hold times require adjustment whenever a signal standard other than LVCMOS25 is assigned to the data Input. If this is true, subtract the appropriate Input adjustment from Table 23. When the hold time is negative, it is possible to change the data before the clock's active edge.

Table 21: Sample Window (Source Synchronous)

Symbol	Description	Max	Units
T _{SAMP}	Setup and hold capture window of an IOB flip-flop	The input capture sample window value is highly specific to a particular application, device, package, I/O standard, I/O placement, DCM usage, and clock buffer. Please consult the appropriate Xilinx Answer Record for application-specific values. <ul style="list-style-type: none"> • Answer Record 30879 	ps

Input Propagation Times

Table 22: Propagation Times for the IOB Input Path

Symbol	Description	Conditions	IFD_DELAY_VALUE	Device	Speed Grade: -4	Units	
					Max		
Propagation Times							
T _{IOPLI}	The time it takes for data to travel from the Input pin through the IFF latch to the I output with no input delay programmed	LVCMOS25 ⁽²⁾	0	XA3SD1800A	2.04	ns	
				XA3SD3400A	2.11	ns	
T _{IOPLID}	The time it takes for data to travel from the Input pin through the IFF latch to the I output with the input delay programmed	LVCMOS25 ⁽²⁾	1	XA3SD1800A	2.47	ns	
					2	3.06	ns
					3	3.86	ns
					4	4.43	ns
					5	4.39	ns
					6	5.32	ns
					7	6.24	ns
					8	6.86	ns
			1	XA3SD3400A	2.67	ns	
					2	3.25	ns
					3	4.04	ns
					4	4.62	ns
					5	4.49	ns
					6	5.31	ns
					7	6.18	ns
					8	6.78	ns

Notes:

1. The numbers in this table are tested using the methodology presented in [Table 27](#) and are based on the operating conditions set forth in [Table 8](#) and [Table 11](#).
2. This propagation time requires adjustment whenever a signal standard other than LVCMOS25 is assigned to the data Input. When this is true, add the appropriate Input adjustment from [Table 23](#).

Input Timing Adjustments

Table 23: Input Timing Adjustments by IOSTANDARD

Convert Input Time from LVCMOS25 to the Following Signal Standard (IOSTANDARD)	Add the Adjustment Below	Units
	Speed Grade: -4	
Single-Ended Standards		
LVTTTL	0.62	ns
LVCMOS33	0.54	ns
LVCMOS25	0.00	ns
LVCMOS18	0.83	ns
LVCMOS15	0.60	ns
LVCMOS12	0.31	ns
PCI33_3	0.45	ns

Table 23: Input Timing Adjustments by IOSTANDARD (Cont'd)

Convert Input Time from LVCMOS25 to the Following Signal Standard (IOSTANDARD)	Add the Adjustment Below	Units
	Speed Grade: -4	
HSTL_I	0.72	ns
HSTL_III	0.85	ns
HSTL_I_18	0.69	ns
HSTL_II_18	0.83	ns
HSTL_III_18	0.79	ns
SSTL18_I	0.71	ns
SSTL18_II	0.71	ns
SSTL2_I	0.71	ns
SSTL2_II	0.71	ns
SSTL3_I	0.78	ns
SSTL3_II	0.78	ns
Differential Standards		
LVDS_25	0.79	ns
LVDS_33	0.79	ns
BLVDS_25	0.79	ns
MINI_LVDS_25	0.84	ns
MINI_LVDS_33	0.84	ns
LVPECL_25	0.80	ns
LVPECL_33	0.80	ns
RSDS_25	0.83	ns
RSDS_33	0.83	ns
TMDS_33	0.80	ns
PPDS_25	0.81	ns
PPDS_33	0.81	ns
DIFF_HSTL_I_18	0.80	ns
DIFF_HSTL_II_18	0.98	ns
DIFF_HSTL_III_18	1.05	ns
DIFF_HSTL_I	0.77	ns
DIFF_HSTL_III	1.05	ns
DIFF_SSTL18_I	0.76	ns
DIFF_SSTL18_II	0.76	ns
DIFF_SSTL2_I	0.77	ns
DIFF_SSTL2_II	0.77	ns
DIFF_SSTL3_I	1.06	ns
DIFF_SSTL3_II	1.06	ns

Notes:

1. The numbers in this table are tested using the methodology presented in Table 27 and are based on the operating conditions set forth in Table 8, Table 11, and Table 13.
2. These adjustments are used to convert input path times originally specified for the LVCMOS25 standard to times that correspond to other signal standards.

Output Propagation Times

Table 24: Timing for the IOB Output Path

Symbol	Description	Conditions	Device	Speed Grade: -4	Units
				Max	
Clock-to-Output Times					
T_{IOCKP}	When reading from the Output Flip-Flop (OFF), the time from the active transition at the OCLK input to data appearing at the Output pin	LVC MOS25 ⁽²⁾ , 12 mA output drive, Fast slew rate	All	3.13	ns
Propagation Times					
T_{IOOP}	The time it takes for data to travel from the JOB's O input to the Output pin	LVC MOS25 ⁽²⁾ , 12 mA output drive, Fast slew rate	All	2.91	ns
T_{IOOLP}	The time it takes for data to travel from the O input through the OFF latch to the Output pin		All	2.85	ns
Set/Reset Times					
T_{IOSRP}	Time from asserting the OFF's SR input to setting/resetting data at the Output pin	LVC MOS25 ⁽²⁾ , 12 mA output drive, Fast slew rate	All	3.89	ns
T_{IOGSRQ}	Time from asserting the Global Set Reset (GSR) input on the STARTUP_SPARTAN3A primitive to setting/resetting data at the Output pin		All	9.65	ns

Notes:

1. The numbers in this table are tested using the methodology presented in Table 27 and are based on the operating conditions set forth in Table 8 and Table 11.
2. This time requires adjustment whenever a signal standard other than LVC MOS25 with 12 mA drive and Fast slew rate is assigned to the data Output. When this is true, add the appropriate Output adjustment from Table 26.

Three-State Output Propagation Times

Table 25: Timing for the IOB Three-State Path

Symbol	Description	Conditions	Device	Speed Grade: -4	Units
				Max	
Synchronous Output Enable/Disable Times					
T_{IOCKHZ}	Time from the active transition at the OTCLK input of the Three-state Flip-Flop (TFF) to when the Output pin enters the high-impedance state	LVC MOS25, 12 mA output drive, Fast slew rate	All	1.39	ns
$T_{IOCKON}^{(2)}$	Time from the active transition at TFF's OTCLK input to when the Output pin drives valid data		All	3.35	ns
Asynchronous Output Enable/Disable Times					
T_{GTS}	Time from asserting the Global Three State (GTS) input on the STARTUP_SPARTAN3A primitive to when the Output pin enters the high-impedance state	LVC MOS25, 12 mA output drive, Fast slew rate	All	10.36	ns
Set/Reset Times					
T_{IOSRHZ}	Time from asserting TFF's SR input to when the Output pin enters a high-impedance state	LVC MOS25, 12 mA output drive, Fast slew rate	All	1.86	ns
$T_{IOSRON}^{(2)}$	Time from asserting TFF's SR input at TFF to when the Output pin drives valid data		All	3.82	ns

Notes:

1. The numbers in this table are tested using the methodology presented in Table 27 and are based on the operating conditions set forth in Table 8 and Table 11.
2. This time requires adjustment whenever a signal standard other than LVC MOS25 with 12 mA drive and Fast slew rate is assigned to the data Output. When this is true, add the appropriate Output adjustment from Table 26.

Output Timing Adjustments

Table 26: Output Timing Adjustments for IOB

Convert Output Time from LVCMOS25 with 12mA Drive and Fast Slew Rate to the Following Signal Standard (IOSTANDARD)			Add the Adjustment Below	Units
			Speed Grade: -4	
Single-Ended Standards				
LVTTTL	Slow	2 mA	5.58	ns
		4 mA	3.44	ns
		6 mA	3.44	ns
		8 mA	2.26	ns
		12 mA	1.66	ns
		16 mA	1.29	ns
		24 mA	2.97	ns
	Fast	2 mA	3.37	ns
		4 mA	2.26	ns
		6 mA	2.26	ns
		8 mA	0.62	ns
		12 mA	0.61	ns
		16 mA	0.59	ns
		24 mA	0.60	ns
	QuietIO	2 mA	27.67	ns
		4 mA	27.67	ns
		6 mA	27.67	ns
		8 mA	16.71	ns
		12 mA	16.67	ns
		16 mA	16.22	ns
		24 mA	12.11	ns

Table 26: Output Timing Adjustments for IOB (Cont'd)

Convert Output Time from LVCMOS25 with 12mA Drive and Fast Slew Rate to the Following Signal Standard (IOSTANDARD)			Add the Adjustment Below	Units
			Speed Grade: -4	
LVCMOS33	Slow	2 mA	5.58	ns
		4 mA	3.30	ns
		6 mA	3.30	ns
		8 mA	2.26	ns
		12 mA	1.29	ns
		16 mA	1.21	ns
		24 mA	2.79	ns
	Fast	2 mA	3.72	ns
		4 mA	2.04	ns
		6 mA	2.08	ns
		8 mA	0.53	ns
		12 mA	0.59	ns
		16 mA	0.59	ns
		24 mA	0.51	ns
	QuietIO	2 mA	27.67	ns
		4 mA	27.67	ns
		6 mA	27.67	ns
		8 mA	16.71	ns
		12 mA	16.29	ns
		16 mA	16.18	ns
		24 mA	12.11	ns

Table 26: Output Timing Adjustments for IOB (Cont'd)

Convert Output Time from LVCMOS25 with 12mA Drive and Fast Slew Rate to the Following Signal Standard (IOSTANDARD)			Add the Adjustment Below	Units
			Speed Grade: -4	
LVCMOS25	Slow	2 mA	5.33	ns
		4 mA	2.90	ns
		6 mA	2.91	ns
		8 mA	1.22	ns
		12 mA	1.22	ns
		16 mA	0.90	ns
		24 mA	2.31	ns
	Fast	2 mA	4.71	ns
		4 mA	2.19	ns
		6 mA	1.49	ns
		8 mA	0.39	ns
		12 mA	0.00	ns
		16 mA	0.01	ns
		24 mA	0.01	ns
	QuietIO	2 mA	25.92	ns
		4 mA	25.92	ns
		6 mA	25.92	ns
		8 mA	15.57	ns
		12 mA	15.59	ns
		16 mA	14.27	ns
		24 mA	11.37	ns
LVCMOS18	Slow	2 mA	5.00	ns
		4 mA	3.69	ns
		6 mA	2.91	ns
		8 mA	2.02	ns
		12 mA	1.57	ns
		16 mA	1.19	ns
	Fast	2 mA	4.12	ns
		4 mA	2.62	ns
		6 mA	1.91	ns
		8 mA	1.06	ns
		12 mA	0.83	ns
		16 mA	0.63	ns
	QuietIO	2 mA	24.97	ns
		4 mA	24.97	ns
		6 mA	24.08	ns
		8 mA	16.43	ns
		12 mA	14.52	ns
		16 mA	13.41	ns

Table 26: Output Timing Adjustments for IOB (Cont'd)

Convert Output Time from LVCMOS25 with 12mA Drive and Fast Slew Rate to the Following Signal Standard (IOSTANDARD)			Add the Adjustment Below	Units
			Speed Grade: -4	
LVCMOS15	Slow	2 mA	6.41	ns
		4 mA	3.97	ns
		6 mA	3.21	ns
		8 mA	2.53	ns
		12 mA	2.06	ns
	Fast	2 mA	5.83	ns
		4 mA	3.05	ns
		6 mA	1.95	ns
		8 mA	1.60	ns
		12 mA	1.30	ns
	QuietIO	2 mA	34.11	ns
		4 mA	25.66	ns
		6 mA	24.64	ns
		8 mA	22.06	ns
		12 mA	20.64	ns
LVCMOS12	Slow	2 mA	7.14	ns
		4 mA	4.87	ns
		6 mA	5.67	ns
	Fast	2 mA	6.77	ns
		4 mA	5.02	ns
		6 mA	4.09	ns
	QuietIO	2 mA	50.76	ns
		4 mA	43.17	ns
		6 mA	37.31	ns
PCI33_3			0.34	ns
HSTL_I			0.85	ns
HSTL_III			1.16	ns
HSTL_I_18			0.35	ns
HSTL_II_18			0.30	ns
HSTL_III_18			0.47	ns
SSTL18_I			0.40	ns
SSTL18_II			0.30	ns
SSTL2_I			0.00	ns
SSTL2_II			-0.05	ns
SSTL3_I			0.00	ns
SSTL3_II			0.17	ns

Table 26: Output Timing Adjustments for IOB (Cont'd)

Convert Output Time from LVCMOS25 with 12mA Drive and Fast Slew Rate to the Following Signal Standard (IOSTANDARD)	Add the Adjustment Below	Units
	Speed Grade: -4	
Differential Standards		
LVDS_25	1.49	ns
LVDS_33	0.46	ns
BLVDS_25	0.11	ns
MINI_LVDS_25	1.11	ns
MINI_LVDS_33	0.41	ns
LVPECL_25	Input Only	
LVPECL_33		
RSDS_25	1.72	ns
RSDS_33	0.64	ns
TMDS_33	0.46	ns
PPDS_25	1.28	ns
PPDS_33	0.88	ns
DIFF_HSTL_I_18	0.43	ns
DIFF_HSTL_II_18	0.41	ns
DIFF_HSTL_III_18	0.36	ns
DIFF_HSTL_I	1.01	ns
DIFF_HSTL_III	1.16	ns
DIFF_SSTL18_I	0.49	ns
DIFF_SSTL18_II	0.41	ns
DIFF_SSTL2_I	0.91	ns
DIFF_SSTL2_II	0.10	ns
DIFF_SSTL3_I	1.18	ns
DIFF_SSTL3_II	0.28	ns

Notes:

1. The numbers in this table are tested using the methodology presented in Table 27 and are based on the operating conditions set forth in Table 8, Table 11, and Table 13.
2. These adjustments are used to convert output- and three-state-path times originally specified for the LVCMOS25 standard with 12 mA drive and Fast slew rate to times that correspond to other signal standards. Do not adjust times that measure when outputs go into a high-impedance state.

Timing Measurement Methodology

When measuring timing parameters at the programmable I/Os, different signal standards call for different test conditions. [Table 27](#) lists the conditions to use for each standard.

The method for measuring Input timing is as follows: A signal that swings between a Low logic level of V_L and a High logic level of V_H is applied to the Input under test. Some standards also require the application of a bias voltage to the V_{REF} pins of a given bank to properly set the input-switching threshold. The measurement point of the Input signal (V_M) is commonly located halfway between V_L and V_H .

The Output test setup is shown in [Figure 9](#). A termination voltage V_T is applied to the termination resistor R_T , the other end of which is connected to the Output. For each standard, R_T and V_T generally take on the standard values recommended for minimizing signal reflections. If the standard does not ordinarily use terminations (for example, LVCMOS, LVTTTL), then R_T is set to 1 M Ω to indicate an open connection, and V_T is set to zero. The same measurement point (V_M) that was used at the Input is also used at the Output.

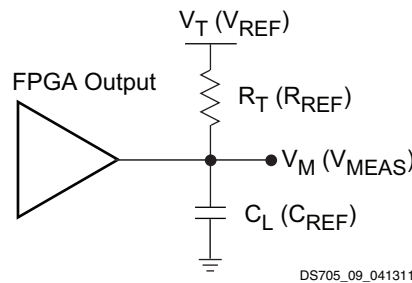

Notes:

1. The names shown in parentheses are used in the IBIS file.

Figure 9: Output Test Setup

Table 27: Test Methods for Timing Measurement at I/Os

Signal Standard (IOSTANDARD)	Inputs			Outputs		Inputs and Outputs
	V_{REF} (V)	V_L (V)	V_H (V)	R_T (Ω)	V_T (V)	V_M (V)
Single-Ended						
LVTTTL	–	0	3.3	1M	0	1.4
LVCMOS33	–	0	3.3	1M	0	1.65
LVCMOS25	–	0	2.5	1M	0	1.25
LVCMOS18	–	0	1.8	1M	0	0.9
LVCMOS15	–	0	1.5	1M	0	0.75
LVCMOS12	–	0	1.2	1M	0	0.6
PCI33_3	Rising	Note 3	Note 3	25	0	0.94
	Falling			25	3.3	2.03
HSTL_I	0.75	$V_{REF} - 0.5$	$V_{REF} + 0.5$	50	0.75	V_{REF}
HSTL_III	0.9	$V_{REF} - 0.5$	$V_{REF} + 0.5$	50	1.5	V_{REF}
HSTL_I_18	0.9	$V_{REF} - 0.5$	$V_{REF} + 0.5$	50	0.9	V_{REF}
HSTL_II_18	0.9	$V_{REF} - 0.5$	$V_{REF} + 0.5$	25	0.9	V_{REF}
HSTL_III_18	1.1	$V_{REF} - 0.5$	$V_{REF} + 0.5$	50	1.8	V_{REF}
SSTL18_I	0.9	$V_{REF} - 0.5$	$V_{REF} + 0.5$	50	0.9	V_{REF}
SSTL18_II	0.9	$V_{REF} - 0.5$	$V_{REF} + 0.5$	25	0.9	V_{REF}
SSTL2_I	1.25	$V_{REF} - 0.75$	$V_{REF} + 0.75$	50	1.25	V_{REF}

Table 27: Test Methods for Timing Measurement at I/Os (Cont'd)

Signal Standard (IOSTANDARD)	Inputs			Outputs		Inputs and Outputs
	V _{REF} (V)	V _L (V)	V _H (V)	R _T (Ω)	V _T (V)	V _M (V)
SSTL2_II	1.25	V _{REF} - 0.75	V _{REF} + 0.75	25	1.25	V _{REF}
SSTL3_I	1.5	V _{REF} - 0.75	V _{REF} + 0.75	50	1.5	V _{REF}
SSTL3_II	1.5	V _{REF} - 0.75	V _{REF} + 0.75	25	1.5	V _{REF}
Differential						
LVDS_25	–	V _{ICM} - 0.125	V _{ICM} + 0.125	50	1.2	V _{ICM}
LVDS_33	–	V _{ICM} - 0.125	V _{ICM} + 0.125	50	1.2	V _{ICM}
BLVDS_25	–	V _{ICM} - 0.125	V _{ICM} + 0.125	1M	0	V _{ICM}
MINI_LVDS_25	–	V _{ICM} - 0.125	V _{ICM} + 0.125	50	1.2	V _{ICM}
MINI_LVDS_33	–	V _{ICM} - 0.125	V _{ICM} + 0.125	50	1.2	V _{ICM}
LVPECL_25	–	V _{ICM} - 0.3	V _{ICM} + 0.3	N/A	N/A	V _{ICM}
LVPECL_33	–	V _{ICM} - 0.3	V _{ICM} + 0.3	N/A	N/A	V _{ICM}
RSDS_25	–	V _{ICM} - 0.1	V _{ICM} + 0.1	50	1.2	V _{ICM}
RSDS_33	–	V _{ICM} - 0.1	V _{ICM} + 0.1	50	1.2	V _{ICM}
TMDS_33	–	V _{ICM} - 0.1	V _{ICM} + 0.1	50	3.3	V _{ICM}
PPDS_25	–	V _{ICM} - 0.1	V _{ICM} + 0.1	50	0.8	V _{ICM}
PPDS_33	–	V _{ICM} - 0.1	V _{ICM} + 0.1	50	0.8	V _{ICM}
DIFF_HSTL_I	0.9	V _{REF} - 0.5	V _{REF} + 0.5	50	0.9	V _{REF}
DIFF_HSTL_III	0.9	V _{REF} - 0.5	V _{REF} + 0.5	50	0.9	V _{REF}
DIFF_HSTL_I_18	0.9	V _{REF} - 0.5	V _{REF} + 0.5	50	0.9	V _{REF}
DIFF_HSTL_II_18	0.9	V _{REF} - 0.5	V _{REF} + 0.5	50	0.9	V _{REF}
DIFF_HSTL_III_18	1.1	V _{REF} - 0.5	V _{REF} + 0.5	50	1.8	V _{REF}
DIFF_SSTL18_I	0.9	V _{REF} - 0.5	V _{REF} + 0.5	50	0.9	V _{REF}
DIFF_SSTL18_II	0.9	V _{REF} - 0.5	V _{REF} + 0.5	50	0.9	V _{REF}
DIFF_SSTL2_I	1.25	V _{REF} - 0.5	V _{REF} + 0.5	50	1.25	V _{REF}
DIFF_SSTL2_II	1.25	V _{REF} - 0.5	V _{REF} + 0.5	50	1.25	V _{REF}
DIFF_SSTL3_I	1.5	V _{REF} - 0.5	V _{REF} + 0.5	50	1.5	V _{REF}
DIFF_SSTL3_II	1.5	V _{REF} - 0.5	V _{REF} + 0.5	50	1.5	V _{REF}

Notes:

- Descriptions of the relevant symbols are as follows:
V_{REF} – The reference voltage for setting the input switching threshold
V_{ICM} – The common mode input voltage
V_M – Voltage of measurement point on signal transition
V_L – Low-level test voltage at Input pin
V_H – High-level test voltage at Input pin
R_T – Effective termination resistance, which takes on a value of 1 MΩ when no parallel termination is required
V_T – Termination voltage
- The load capacitance (C_L) at the Output pin is 0 pF for all signal standards.
- According to the PCI specification.

The capacitive load (C_L) is connected between the output and GND. *The Output timing for all standards, as published in the speed files and the data sheet, is always based on a C_L value of zero.* High-impedance probes (less than 1 pF) are used for all measurements. Any delay that the test fixture might contribute to test measurements is subtracted from those measurements to produce the final timing numbers as published in the speed files and data sheet.

Using IBIS Models to Simulate Load Conditions in Application

IBIS models permit the most accurate prediction of timing delays for a given application. The parameters found in the IBIS model (V_{REF} , R_{REF} and V_{MEAS}) correspond directly with the parameters used in [Table 27](#) (V_T , R_T , and V_M). Do not confuse V_{REF} (the termination voltage) from the IBIS model with V_{REF} (the input-switching threshold) from the table. A fourth parameter, C_{REF} is always zero. The four parameters describe all relevant output test conditions. IBIS models are found in the Xilinx development software as well as at the following link:

www.xilinx.com/support/download/index.htm

Delays for a given application are simulated according to its specific load conditions as follows:

1. Simulate the desired signal standard with the output driver connected to the test setup shown in [Figure 9](#). Use parameter values V_T , R_T , and V_M from [Table 27](#). C_{REF} is zero.
2. Record the time to V_M .
3. Simulate the same signal standard with the output driver connected to the PCB trace with load. Use the appropriate IBIS model (including V_{REF} , R_{REF} , C_{REF} and V_{MEAS} values) or capacitive value to represent the load.
4. Record the time to V_{MEAS} .
5. Compare the results of steps 2 and 4. Add (or subtract) the increase (or decrease) in delay to (or from) the appropriate Output standard adjustment ([Table 26](#)) to yield the worst-case delay of the PCB trace.

Simultaneously Switching Output Guidelines

This section provides guidelines for the recommended maximum allowable number of Simultaneous Switching Outputs (SSOs). These guidelines describe the maximum number of user I/O pins of a given output signal standard that should simultaneously switch in the same direction, while maintaining a safe level of switching noise. Meeting these guidelines for the stated test conditions ensures that the FPGA operates free from the adverse effects of ground and power bounce.

Ground or power bounce occurs when a large number of outputs simultaneously switch in the same direction. The output drive transistors all conduct current to a common voltage rail. Low-to-High transitions conduct to the V_{CCO} rail; High-to-Low transitions conduct to the GND rail. The resulting cumulative current transient induces a voltage difference across the inductance that exists between the die pad and the power supply or ground return. The inductance is associated with bonding wires, the package lead frame, and any other signal routing inside the package. Other variables contribute to SSO noise levels, including stray inductance on the PCB as well as capacitive loading at receivers. Any SSO-induced voltage consequently affects internal switching noise margins and ultimately signal quality.

[Table 28](#) and [Table 29](#) provide the essential SSO guidelines. For each device/package combination, [Table 28](#) provides the number of equivalent V_{CCO}/GND pairs. The equivalent number of pairs is based on characterization and may not match the physical number of pairs. For each output signal standard and drive strength, [Table 29](#) recommends the maximum number of SSOs, switching in the same direction, allowed per V_{CCO}/GND pair within an I/O bank. The guidelines in [Table 29](#) are categorized by package style, slew rate, and output drive current. Furthermore, the number of SSOs is specified by I/O bank. Generally, the left and right I/O banks (Banks 1 and 3) support higher output drive current.

Multiply the appropriate numbers from [Table 28](#) and [Table 29](#) to calculate the maximum number of SSOs allowed within an I/O bank. Exceeding these SSO guidelines might result in increased power or ground bounce, degraded signal integrity, or increased system jitter.

$$SSO_{MAX}/IO \text{ Bank} = \text{Table 28} \times \text{Table 29}$$

The recommended maximum SSO values assumes that the FPGA is soldered on the printed circuit board and that the board uses sound design practices. The SSO values do not apply for FPGAs mounted in sockets, due to the lead inductance introduced by the socket.

The SSO values assume that the V_{CCAUX} is powered at 3.3V. Setting V_{CCAUX} to 2.5V provides better SSO characteristics.

Table 28: Equivalent V_{CCO}/GND Pairs per Bank

Device	Package Style (Pb-free)	
	CSG484	FGG676
XA3SD1800A	6	9
XA3SD3400A	6	10

Table 29: Recommended Number of Simultaneously Switching Outputs per V_{CCO}/GND Pair (V_{CCAUX}=3.3V)

Signal Standard (IOSTANDARD)			Package Type: CSG484 and FGG676	
			Top, Bottom (Banks 0,2)	Left, Right (Banks 1,3)
Single-Ended Standards				
LVTTL	Slow	2	60	60
		4	41	41
		6	29	29
		8	22	22
		12	13	13
		16	11	11
		24	9	9
	Fast	2	10	10
		4	6	6
		6	5	5
		8	3	3
		12	3	3
		16	3	3
		24	2	2
	QuietIO	2	80	80
		4	48	48
		6	36	36
		8	27	27
		12	16	16
		16	13	13
		24	12	12

Table 29: Recommended Number of Simultaneously Switching Outputs per V_{CCO}/GND Pair (V_{CCAUX}=3.3V) (Cont'd)

Signal Standard (IOSTANDARD)			Package Type: CSG484 and FGG676	
			Top, Bottom (Banks 0,2)	Left, Right (Banks 1,3)
LVCMOS33	Slow	2	76	76
		4	46	46
		6	27	27
		8	20	20
		12	13	13
		16	10	10
		24	–	9
	Fast	2	10	10
		4	8	8
		6	5	5
		8	4	4
		12	4	4
		16	2	2
		24	–	2
	QuietIO	2	76	76
		4	46	46
		6	32	32
		8	26	26
		12	18	18
		16	14	14
		24	–	10

Table 29: Recommended Number of Simultaneously Switching Outputs per V_{CCO}/GND Pair (V_{CCAUX}=3.3V) (Cont'd)

Signal Standard (IOSTANDARD)			Package Type: CSG484 and FGG676	
			Top, Bottom (Banks 0,2)	Left, Right (Banks 1,3)
LVCMOS25	Slow	2	76	76
		4	46	46
		6	33	33
		8	24	24
		12	18	18
		16	–	11
		24	–	7
	Fast	2	18	18
		4	14	14
		6	6	6
		8	6	6
		12	3	3
		16	–	3
		24	–	2
	QuietIO	2	76	76
		4	60	60
		6	48	48
		8	36	36
		12	36	36
		16	–	36
		24	–	8
LVCMOS18	Slow	2	64	64
		4	34	34
		6	22	22
		8	18	18
		12	–	13
		16	–	10
	Fast	2	18	18
		4	9	9
		6	7	7
		8	4	4
		12	–	4
		16	–	3
	QuietIO	2	64	64
		4	64	64
		6	48	48
		8	36	36
		12	–	36
		16	–	24

Table 29: Recommended Number of Simultaneously Switching Outputs per V_{CCO}/GND Pair (V_{CCAUX}=3.3V) (Cont'd)

Signal Standard (IOSTANDARD)			Package Type: CSG484 and FGG676	
			Top, Bottom (Banks 0,2)	Left, Right (Banks 1,3)
LVCMOS15	Slow	2	55	55
		4	31	31
		6	18	18
		8	–	15
		12	–	10
	Fast	2	25	25
		4	10	10
		6	6	6
		8	–	4
		12	–	3
	QuietIO	2	70	70
		4	40	40
		6	31	31
		8	–	31
		12	–	20
LVCMOS12	Slow	2	40	40
		4	–	25
		6	–	18
	Fast	2	31	31
		4	–	13
		6	–	9
	QuietIO	2	55	55
		4	–	36
		6	–	36
PCI33_3			16	16
HSTL_I			–	20
HSTL_III			–	8
HSTL_I_18			17	17
HSTL_II_18			–	5
HSTL_III_18			10	8
SSTL18_I			7	15
SSTL18_II			–	9
SSTL2_I			18	18
SSTL2_II			–	9
SSTL3_I			8	10
SSTL3_II			6	7

Table 29: Recommended Number of Simultaneously Switching Outputs per V_{CCO}/GND Pair (V_{CCAUX}=3.3V) (Cont'd)

Signal Standard (IOSTANDARD)	Package Type: CSG484 and FGG676	
	Top, Bottom (Banks 0,2)	Left, Right (Banks 1,3)
Differential Standards (Number of I/O Pairs or Channels)		
LVDS_25	22	–
LVDS_33	27	–
BLVDS_25	4	4
MINI_LVDS_25	22	–
MINI_LVDS_33	27	–
LVPECL_25	Inputs Only	
LVPECL_33		
RSDS_25	22	–
RSDS_33	27	–
TMDS_33	27	–
PPDS_25	22	–
PPDS_33	27	–
DIFF_HSTL_I_18	8	8
DIFF_HSTL_II_18	–	2
DIFF_HSTL_III_18	5	4
DIFF_HSTL_I	–	10
DIFF_HSTL_III	–	4
DIFF_SSTL18_I	3	7
DIFF_SSTL18_II	–	1
DIFF_SSTL2_I	9	9
DIFF_SSTL2_II	–	4
DIFF_SSTL3_I	4	5
DIFF_SSTL3_II	3	3

Notes:

1. Not all I/O standards are supported on all I/O banks. The left and right banks (I/O banks 1 and 3) support higher output drive current than the top and bottom banks (I/O banks 0 and 2). Similarly, true differential output standards, such as LVDS, RSDS, PPDS, miniLVDS, and TMDS, are only supported in top or bottom banks (I/O banks 0 and 2). Refer to [UG331](#), *Spartan-3 Generation FPGA User Guide* for additional information.
2. The numbers in this table are recommendations that assume sound board layout practice. This table assumes the following parasitic factors: combined PCB trace and land inductance per V_{CCO} and GND pin of 1.0 nH, receiver capacitive load of 15 pF. Test limits are the V_{IL}/V_{IH} voltage limits for the respective I/O standard.
3. If more than one signal standard is assigned to the I/Os of a given bank, refer to [XAPP689](#), *Managing Ground Bounce in Large FPGAs* for information on how to perform weighted average SSO calculations.

Configurable Logic Block Timing

Table 30: CLB (SLICEM) Timing

Symbol	Description	Speed Grade: -4		Units
		Min	Max	
Clock-to-Output Times				
T_{CKO}	When reading from the FFX (FFY) Flip-Flop, the time from the active transition at the CLK input to data appearing at the XQ (YQ) output	–	0.68	ns
Setup Times				
T_{AS}	Time from the setup of data at the F or G input to the active transition at the CLK input of the CLB	0.36	–	ns
T_{DICK}	Time from the setup of data at the BX or BY input to the active transition at the CLK input of the CLB	1.88	–	ns
Hold Times				
T_{AH}	Time from the active transition at the CLK input to the point where data is last held at the F or G input	0.00	–	ns
T_{CKDI}	Time from the active transition at the CLK input to the point where data is last held at the BX or BY input	0.00	–	ns
Clock Timing				
T_{CH}	The High pulse width of the CLB's CLK signal	0.75	–	ns
T_{CL}	The Low pulse width of the CLK signal	0.75	–	ns
F_{TOG}	Toggle frequency (for export control)	0	667	MHz
Propagation Times				
T_{ILO}	The time it takes for data to travel from the CLB's F (G) input to the X (Y) output	–	0.71	ns
Set/Reset Pulse Width				
T_{RPW_CLB}	The minimum allowable pulse width, High or Low, to the CLB's SR input	1.61	–	ns

Notes:

- The numbers in this table are based on the operating conditions set forth in [Table 8](#).

Table 31: CLB Distributed RAM Switching Characteristics

Symbol	Description	Speed Grade: -4		Units
		Min	Max	
Clock-to-Output Times				
T_{SHCKO}	Time from the active edge at the CLK input to data appearing on the distributed RAM output	–	1.72	ns
Setup Times				
T_{DS}	Setup time of data at the BX or BY input before the active transition at the CLK input of the distributed RAM	–0.02	–	ns
T_{AS}	Setup time of the F/G address inputs before the active transition at the CLK input of the distributed RAM	0.36	–	ns
T_{WS}	Setup time of the write enable input before the active transition at the CLK input of the distributed RAM	0.59	–	ns
Hold Times				
T_{DH}	Hold time of the BX and BY data inputs after the active transition at the CLK input of the distributed RAM	0.13	–	ns
T_{AH}, T_{WH}	Hold time of the F/G address inputs or the write enable input after the active transition at the CLK input of the distributed RAM	0.01	–	ns
Clock Pulse Width				
T_{WPH}, T_{WPL}	Minimum High or Low pulse width at CLK input	1.01	–	ns

Table 32: CLB Shift Register Switching Characteristics

Symbol	Description	Speed Grade: -4		Units
		Min	Max	
Clock-to-Output Times				
T_{REG}	Time from the active edge at the CLK input to data appearing on the shift register output	–	4.82	ns
Setup Times				
T_{SRLDS}	Setup time of data at the BX or BY input before the active transition at the CLK input of the shift register	0.18	–	ns
Hold Times				
T_{SRLDH}	Hold time of the BX or BY data input after the active transition at the CLK input of the shift register	0.16	–	ns
Clock Pulse Width				
T_{WPH}, T_{WPL}	Minimum High or Low pulse width at CLK input	1.01	–	ns

Clock Buffer/Multiplexer Switching Characteristics

Table 33: Clock Distribution Switching Characteristics

Description	Symbol	Minimum	Maximum	Units
Global clock buffer (BUFG, BUFGMUX, BUFGCE) I input to O-output delay	T_{GIO}	–	0.23	ns
Global clock multiplexer (BUFGMUX) select S-input setup to I0 and I1 inputs. Same as BUFGCE enable CE-input	T_{GSI}	–	0.63	ns
Frequency of signals distributed on global buffers (all sides)	F_{BUFG}	0	334	MHz

Notes:

1. The numbers in this table are based on the operating conditions set forth in Table 8.

Block RAM Timing

Table 34: Block RAM Timing

Symbol	Description	Speed Grade: -4		Units
		Min	Max	
Clock-to-Output Times				
$T_{RCKO_DOA_NC}$	When reading from block RAM, the delay from the active transition at the CLK input to data appearing at the DOUT output	–	2.80	ns
T_{RCKO_DOA}	Clock CLK to DOUT output (with output register)	–	1.45	ns
Setup Times				
T_{RCKC_ADDR}	Setup time for the ADDR inputs before the active transition at the CLK input of the block RAM	0.46	–	ns
T_{RDCK_DIB}	Setup time for data at the DIN inputs before the active transition at the CLK input of the block RAM	0.33	–	ns
T_{RCKC_ENB}	Setup time for the EN input before the active transition at the CLK input of the block RAM	0.60	–	ns
T_{RCKC_WEB}	Setup time for the WE input before the active transition at the CLK input of the block RAM	0.75	–	ns
T_{RCKC_REGCE}	Setup time for the CE input before the active transition at the CLK input of the block RAM	0.40	–	ns
T_{RCKC_RST}	Setup time for the RST input before the active transition at the CLK input of the block RAM	0.25	–	ns
Hold Times				
T_{RCKC_ADDR}	Hold time on the ADDR inputs after the active transition at the CLK input	0.10	–	ns
T_{RDCK_DIB}	Hold time on the DIN inputs after the active transition at the CLK input	0.10	–	ns
T_{RCKC_ENB}	Hold time on the EN input after the active transition at the CLK input	0.10	–	ns
T_{RCKC_WEB}	Hold time on the WE input after the active transition at the CLK input	0.10	–	ns
T_{RCKC_REGCE}	Hold time on the CE input after the active transition at the CLK input	0.10	–	ns
T_{RCKC_RST}	Hold time on the RST input after the active transition at the CLK input	0.10	–	ns
Clock Timing				
T_{BPWH}	High pulse width of the CLK signal	1.79	–	ns
T_{BPWL}	Low pulse width of the CLK signal	1.79	–	ns
Clock Frequency				
F_{BRAM}	Block RAM clock frequency	0	280	MHz

Notes:

- The numbers in this table are based on the operating conditions set forth in [Table 8](#).

DSP48A Timing

To reference the DSP48A block diagram, see the *XtremeDSP DSP48A for Spartan-3A DSP FPGAs User Guide (UG431)*.

Table 35: Setup Times for the DSP48A

Symbol	Description	Pre-adder	Multiplier	Post-adder	Speed Grade: -4	Units
					Min	
Setup Times of Data/Control Pins to the Input Register Clock						
T _{DSPDCK_AA}	A input to A register CLK	–	–	–	0.04	ns
T _{DSPDCK_DB}	D input to B register CLK	Yes ⁽¹⁾	–	–	1.88	ns
T _{DSPDCK_CC}	C input to C register CLK	–	–	–	0.05	ns
T _{DSPDCK_DD}	D input to D register CLK	–	–	–	0.04	ns
T _{DSPDCK_OPB}	OPMODE input to B register CLK	Yes	–	–	0.42	ns
T _{DSPDCK_OPOP}	OPMODE input to OPMODE register CLK	–	–	–	0.06	ns
Setup Times of Data Pins to the Pipeline Register Clock						
T _{DSPDCK_AM}	A input to M register CLK	–	Yes	–	3.79	ns
T _{DSPDCK_BM}	B input to M register CLK	Yes	Yes	–	4.97	ns
		No	Yes	–	3.79	ns
T _{DSPDCK_DM}	D input to M register CLK	Yes	Yes	–	5.06	ns
T _{DSPDCK_OPM}	OPMODE to M register CLK	Yes	Yes	–	5.42	ns
Setup Times of Data/Control Pins to the Output Register Clock						
T _{DSPDCK_AP}	A input to P register CLK	–	Yes	Yes	5.49	ns
T _{DSPDCK_BP}	B input to P register CLK	Yes	Yes	Yes	6.74	ns
		No	Yes	Yes	5.48	ns
T _{DSPDCK_DP}	D input to P register CLK	Yes	Yes	Yes	6.83	ns
T _{DSPDCK_CP}	C input to P register CLK	–	–	Yes	2.18	ns
T _{DSPDCK_OPP}	OPMODE input to P register CLK	Yes	Yes	Yes	7.18	ns

Notes:

1. “Yes” means that the component is in the path. “No” means that the component is being bypassed. “–” means that no path exists, so it is not applicable.
2. The numbers in this table are based on the operating conditions set forth in [Table 8](#).

Table 36: Clock to Out, Propagation Delays, and Maximum Frequency for the DSP48A

Symbol	Description	Pre-adder	Multiplier	Post-adder	Speed Grade: -4	Units
					Min	
Clock to Out from Output Register Clock to Output Pin						
T _{DSPCKO_PP}	CLK (PREG) to P output	–	–	–	1.44	ns
Clock to Out from Pipeline Register Clock to Output Pins						
T _{DSPCKO_PM}	CLK (MREG) to P output	–	Yes ⁽¹⁾	Yes	3.63	ns
		–	Yes	No	2.23	ns
Clock to Out from Input Register Clock to Output Pins						
T _{DSPCKO_PA}	CLK (AREG) to P output	–	Yes	Yes	7.27	ns
T _{DSPCKO_PB}	CLK (BREG) to P output	Yes	Yes	Yes	8.56	ns
T _{DSPCKO_PC}	CLK (CREG) to P output	–	–	Yes	3.87	ns
T _{DSPCKO_PD}	CLK (DREG) to P output	Yes	Yes	Yes	8.42	ns
Combinatorial Delays from Input Pins to Output Pins						
T _{DSPDO_AP} T _{DSPDO_BP}	A or B input to P output	–	No	Yes	3.19	ns
		–	Yes	No	5.28	ns
		–	Yes	Yes	6.49	ns
T _{DSPDO_BP}	B input to P output	Yes	No	No	4.01	ns
		Yes	Yes	No	6.65	ns
		Yes	Yes	Yes	7.74	ns
T _{DSPDO_CP}	C input to P output	–	–	Yes	3.17	ns
T _{DSPDO_DP}	D input to P output	Yes	Yes	Yes	7.82	ns
T _{DSPDO_OPP}	OPMODE input to P output	Yes	Yes	Yes	8.18	ns
Maximum Frequency						
F _{MAX}	All registers used	Yes	Yes	Yes	250	MHz

Notes:

1. “Yes” means that the component is in the path. “No” means that the component is being bypassed. “–” means that no path exists, so it is not applicable.
2. To reference the DSP48A block diagram, see [UG431](#), *XtremeDSP DSP48A for Spartan-3A DSP FPGAs User Guide*.
3. The numbers in this table are based on the operating conditions set forth in [Table 8](#).

Digital Clock Manager Timing

For specification purposes, the DCM consists of three key components: the Delay-Locked Loop (DLL), the Digital Frequency Synthesizer (DFS), and the Phase Shifter (PS).

Aspects of DLL operation play a role in all DCM applications. All such applications inevitably use the CLKIN and the CLKFB inputs connected to either the CLK0 or the CLK2X feedback, respectively. Thus, specifications in the DLL tables (Table 37 and Table 38) apply to any application that only employs the DLL component. When the DFS and/or the PS components are used together with the DLL, then the specifications listed in the DFS and PS tables (Table 39 through Table 42) supersede any corresponding ones in the DLL tables. DLL specifications that do not change with the addition of DFS or PS functions are presented in Table 37 and Table 38.

Period jitter and cycle-cycle jitter are two of many different ways of specifying clock jitter. Both specifications describe statistical variation from a mean value.

Period jitter is the worst-case deviation from the ideal clock period over a collection of millions of samples. In a histogram of period jitter, the mean value is the clock period.

Cycle-cycle jitter is the worst-case difference in clock period between adjacent clock cycles in the collection of clock periods sampled. In a histogram of cycle-cycle jitter, the mean value is zero.

Delay-Locked Loop

Table 37: Recommended Operating Conditions for the DLL

Symbol		Description	Speed Grade: -4		Units
			Min	Max	
Input Frequency Ranges					
F _{CLKIN}	CLKIN_FREQ_DLL	Frequency of the CLKIN clock input	5 ⁽²⁾	250 ⁽³⁾	MHz
Input Pulse Requirements					
CLKIN_PULSE	CLKIN pulse width as a percentage of the CLKIN period	F _{CLKIN} ≤ 150 MHz	40%	60%	–
		F _{CLKIN} > 150 MHz	45%	55%	–
Input Clock Jitter Tolerance and Delay Path Variation⁽⁴⁾					
CLKIN_CYC_JITT_DLL_LF	Cycle-to-cycle jitter at the CLKIN input	F _{CLKIN} ≤ 150 MHz	–	±300	ps
CLKIN_CYC_JITT_DLL_HF		F _{CLKIN} > 150 MHz	–	±150	ps
CLKIN_PER_JITT_DLL	Period jitter at the CLKIN input		–	±1	ns
CLKFB_DELAY_VAR_EXT	Allowable variation of off-chip feedback delay from the DCM output to the CLKFB input		–	±1	ns

Notes:

1. DLL specifications apply when any of the DLL outputs (CLK0, CLK90, CLK180, CLK270, CLK2X, CLK2X180, or CLKDV) are in use.
2. The DFS, when operating independently of the DLL, supports lower F_{CLKIN} frequencies. See Table 39.
3. To support double the maximum effective F_{CLKIN} limit, set the CLKIN_DIVIDE_BY_2 attribute to TRUE. This attribute divides the incoming clock period by two as it enters the DCM. The CLK2X output reproduces the clock frequency provided on the CLKIN input.
4. CLKIN input jitter beyond these limits might cause the DCM to lose lock.
5. The DCM specifications are guaranteed when both adjacent DCMs are locked.

Table 38: Switching Characteristics for the DLL

Symbol	Description	Device	Speed Grade: -4		Units	
			Min	Max		
Output Frequency Ranges						
CLKOUT_FREQ_CLK0	Frequency for the CLK0 and CLK180 outputs	All	5	250	MHz	
CLKOUT_FREQ_CLK90	Frequency for the CLK90 and CLK270 outputs		5	200	MHz	
CLKOUT_FREQ_2X	Frequency for the CLK2X and CLK2X180 outputs		10	334	MHz	
CLKOUT_FREQ_DV	Frequency for the CLKDV output		0.3125	166	MHz	
Output Clock Jitter^(2,3,4)						
CLKOUT_PER_JITT_0	Period jitter at the CLK0 output	All	–	±100	ps	
CLKOUT_PER_JITT_90	Period jitter at the CLK90 output		–	±150	ps	
CLKOUT_PER_JITT_180	Period jitter at the CLK180 output		–	±150	ps	
CLKOUT_PER_JITT_270	Period jitter at the CLK270 output		–	±150	ps	
CLKOUT_PER_JITT_2X	Period jitter at the CLK2X and CLK2X180 outputs		–	±[0.5% of CLKIN period + 100]	ps	
CLKOUT_PER_JITT_DV1	Period jitter at the CLKDV output when performing integer division		–	±150	ps	
CLKOUT_PER_JITT_DV2	Period jitter at the CLKDV output when performing non-integer division		–	±[0.5% of CLKIN period + 100]	ps	
Duty Cycle⁽⁴⁾						
CLKOUT_DUTY_CYCLE_DLL	Duty cycle variation for the CLK0, CLK90, CLK180, CLK270, CLK2X, CLK2X180, and CLKDV outputs, including the BUFGMUX and clock tree duty-cycle distortion	All	–	±[1% of CLKIN period + 350]	ps	
Phase Alignment⁽⁴⁾						
CLKIN_CLKFB_PHASE	Phase offset between the CLKIN and CLKFB inputs	All	–	±150	ps	
CLKOUT_PHASE_DLL	Phase offset between DLL outputs		CLK0 to CLK2X (not CLK2X180)	–	±[1% of CLKIN period + 100]	ps
			All others	–	±[1% of CLKIN period + 150]	ps
Lock Time						
LOCK_DLL ⁽³⁾	When using the DLL alone: The time from deassertion at the DCM's Reset input to the rising transition at its LOCKED output. When the DCM is locked, the CLKIN and CLKFB signals are in phase	$5 \text{ MHz} \leq F_{\text{CLKIN}} \leq 15 \text{ MHz}$	All	–	5	ms
		$F_{\text{CLKIN}} > 15 \text{ MHz}$		–	600	µs
Delay Lines						
DCM_DELAY_STEP ⁽⁵⁾	Finest delay resolution, averaged over all steps	All	15	35	ps	

Notes:

1. The numbers in this table are based on the operating conditions set forth in Table 8 and Table 37.
2. Indicates the maximum amount of output jitter that the DCM adds to the jitter on the CLKIN input.
3. For optimal jitter tolerance and faster lock time, use the CLKIN_PERIOD attribute.
4. Some jitter and duty-cycle specifications include 1% of input clock period or 0.01 UI. For example, the data sheet specifies a maximum jitter of “±[1% of CLKIN period + 150]”. Assume the CLKIN frequency is 100 MHz. The equivalent CLKIN period is 10 ns and 1% of 10 ns is 0.1 ns or 100 ps. According to the data sheet, the maximum jitter is ±[100 ps + 150 ps] = ±250ps, averaged over all steps.
5. The typical delay step size is 23 ps.

Digital Frequency Synthesizer

Table 39: Recommended Operating Conditions for the DFS

Symbol		Description	Speed Grade: -4		Units
			Min	Max	
Input Frequency Ranges⁽²⁾					
F_{CLKIN}	CLKIN_FREQ_FX	Frequency for the CLKIN input	0.200	333	MHz
Input Clock Jitter Tolerance⁽³⁾					
CLKIN_CYC_JITT_FX_LF	Cycle-to-cycle jitter at the CLKIN input, based on CLKFX output frequency	$F_{CLKFX} \leq 150$ MHz	–	±300	ps
CLKIN_CYC_JITT_FX_HF		$F_{CLKFX} > 150$ MHz	–	±150	ps
CLKIN_PER_JITT_FX	Period jitter at the CLKIN input		–	±1	ns

Notes:

- DFS specifications apply when either of the DFS outputs (CLKFX or CLKFX180) is used.
- If both DFS and DLL outputs are used on the same DCM, follow the more restrictive CLKIN_FREQ_DLL specifications in Table 37.
- CLKIN input jitter beyond these limits may cause the DCM to lose lock.
- The DCM specifications are guaranteed when both adjacent DCMs are locked.

Table 40: Switching Characteristics for the DFS

Symbol		Description	Device	Speed Grade: -4		Units
				Min	Max	
Output Frequency Ranges						
CLKOUT_FREQ_FX ⁽²⁾	Frequency for the CLKFX and CLKFX180 outputs		All	5	311	MHz
Output Clock Jitter^(3,4)						
CLKOUT_PER_JITT_FX	Period jitter at the CLKFX and CLKFX180 outputs.			Typ	Max	
		CLKIN ≤ 20 MHz	All	Use the Spartan-3A Jitter Calculator: www.xilinx.com/support/documentation/data_sheets/s3a_jitter_calc.zip		ps
		CLKIN > 20 MHz		±[1% of CLKFX period + 100]	±[1% of CLKFX period + 200]	ps
Duty Cycle^(5,6)						
CLKOUT_DUTY_CYCLE_FX	Duty cycle precision for the CLKFX and CLKFX180 outputs, including the BUFGMUX and clock tree duty-cycle distortion		All	–	±[1% of CLKFX period + 350]	ps
Phase Alignment⁽⁶⁾						
CLKOUT_PHASE_FX	Phase offset between the DFS CLKFX output and the DLL CLK0 output when both the DFS and DLL are used		All	–	±200	ps
CLKOUT_PHASE_FX180	Phase offset between the DFS CLKFX180 output and the DLL CLK0 output when both the DFS and DLL are used		All	–	±[1% of CLKFX period + 200]	ps

Table 40: Switching Characteristics for the DFS (Cont'd)

Symbol	Description	Device	Speed Grade: -4		Units	
			Min	Max		
Lock Time						
LOCK_FX ^(2,3)	The time from deassertion at the DCM's Reset input to the rising transition at its LOCKED output. The DFS asserts LOCKED when the CLKFX and CLKFX180 signals are valid. If using both the DLL and the DFS, use the longer locking time.	All	$5 \text{ MHz} \leq F_{\text{CLKIN}} \leq 15 \text{ MHz}$	–	5	ms
			$F_{\text{CLKIN}} > 15 \text{ MHz}$	–	450	µs

Notes:

1. The numbers in this table are based on the operating conditions set forth in Table 8 and Table 39.
2. DFS performance requires the additional logic automatically added by ISE 9.1i and later software revisions.
3. For optimal jitter tolerance and faster lock time, use the CLKIN_PERIOD attribute.
4. Maximum output jitter is characterized within a reasonable noise environment (40 SSOs and 25% CLB switching) on an FPGA. Output jitter strongly depends on the environment, including the number of SSOs, the output drive strength, CLB utilization, CLB switching activities, switching frequency, power supply and PCB design. The actual maximum output jitter depends on the system application.
5. The CLKFX and CLKFX180 outputs always have an approximate 50% duty cycle.
6. Some duty-cycle and alignment specifications include a percentage of the CLKFX output period. For example, the data sheet specifies a maximum CLKFX jitter of “±[1% of CLKFX period + 200]”. Assume the CLKFX output frequency is 100 MHz. The equivalent CLKFX period is 10 ns and 1% of 10 ns is 0.1 ns or 100 ps. According to the data sheet, the maximum jitter is ±[100 ps + 200 ps] = ±300 ps.

Phase Shifter

Table 41: Recommended Operating Conditions for the PS in Variable Phase Mode

Symbol	Description	Speed Grade: -4		Units
		Min	Max	
Operating Frequency Ranges				
PSCLK_FREQ (F _{PSCLK})	Frequency for the PSCLK input	1	167	MHz
Input Pulse Requirements				
PSCLK_PULSE	PSCLK pulse width as a percentage of the PSCLK period	40%	60%	–

Table 42: Switching Characteristics for the PS in Variable Phase Mode

Symbol	Description	Phase Shift Amount	Units
Phase Shifting Range			
MAX_STEPS ⁽²⁾	Maximum allowed number of DCM_DELAY_STEP ⁽³⁾ steps for a given CLKIN clock period, where T = CLKIN clock period in ns. If using CLKIN_DIVIDE_BY_2 = TRUE, double the clock effective clock period.	CLKIN < 60 MHz	±[INTEGER(10 • (T _{CLKIN} – 3 ns))] steps
		CLKIN ≥ 60 MHz	±[INTEGER(15 • (T _{CLKIN} – 3 ns))] steps
FINE_SHIFT_RANGE_MIN	Minimum guaranteed delay for variable phase shifting	±[MAX_STEPS • DCM_DELAY_STEP_MIN]	ns
FINE_SHIFT_RANGE_MAX	Maximum guaranteed delay for variable phase shifting	±[MAX_STEPS • DCM_DELAY_STEP_MAX]	ns

Notes:

1. The numbers in this table are based on the operating conditions set forth in Table 8 and Table 41.
2. The maximum variable phase shift range, MAX_STEPS, is only valid when the DCM is has no initial fixed phase shifting, that is, the PHASE_SHIFT attribute is set to 0.
3. The DCM_DELAY_STEP values are provided at the bottom of Table 38.

Miscellaneous DCM Timing

Table 43: Miscellaneous DCM Timing

Symbol	Description	Min	Max	Units
DCM_RST_PW_MIN	Minimum duration of a RST pulse width	3	–	CLKIN cycles

DNA Port Timing

Table 44: DNA_PORT Interface Timing

Symbol	Description	Min	Max	Units
T _{DNASSU}	Setup time on SHIFT before the rising edge of CLK	1.0	–	ns
T _{DNASH}	Hold time on SHIFT after the rising edge of CLK	0.5	–	ns
T _{DNADSU}	Setup time on DIN before the rising edge of CLK	1.0	–	ns
T _{DNADH}	Hold time on DIN after the rising edge of CLK	0.5	–	ns
T _{DNARSU}	Setup time on READ before the rising edge of CLK	5.0	10,000	ns
T _{DNARH}	Hold time on READ after the rising edge of CLK	0.0	–	ns
T _{DNADCKO}	Clock-to-output delay on DOUT after rising edge of CLK	0.5	1.5	ns
T _{DNACLKF}	CLK frequency	0.0	100	MHz
T _{DNACLKH}	CLK High time	1.0	∞	ns
T _{DNACLKL}	CLK Low time	1.0	∞	ns

Notes:

1. The minimum READ pulse width is 5 ns, and the maximum READ pulse width is 10 μs.

Suspend Mode Timing

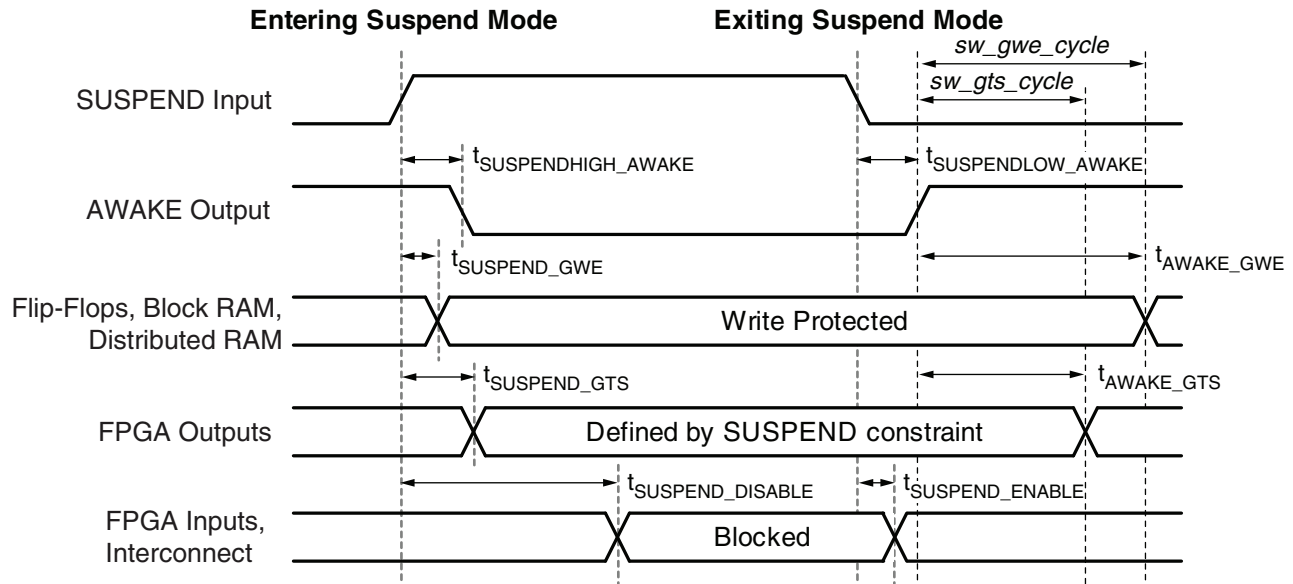

Figure 10: Suspend Mode Timing

DS705_10_041311

Table 45: Suspend Mode Timing Parameters

Symbol	Description	Min	Typ	Max	Units
Entering Suspend Mode					
T _{SUSPENDHIGH_AWAKE}	Rising edge of SUSPEND pin to falling edge of AWAKE pin without glitch filter (<i>suspend_filter:No</i>)	–	7	–	ns
T _{SUSPENDFILTER}	Adjustment to SUSPEND pin rising edge parameters when glitch filter enabled (<i>suspend_filter:Yes</i>)	+160	+300	+600	ns
T _{SUSPEND_GTS}	Rising edge of SUSPEND pin until FPGA output pins drive their defined SUSPEND constraint behavior	–	10	–	ns
T _{SUSPEND_GWE}	Rising edge of SUSPEND pin to write-protect lock on all writable clocked elements	–	<5	–	ns
T _{SUSPEND_DISABLE}	Rising edge of the SUSPEND pin to FPGA input pins and interconnect disabled	–	340	–	ns
Exiting Suspend Mode					
T _{SUSPENDLOW_AWAKE}	Falling edge of the SUSPEND pin to rising edge of the AWAKE pin. Does not include DCM lock time.	–	4 to 108	–	µs
T _{SUSPEND_ENABLE}	Falling edge of the SUSPEND pin to FPGA input pins and interconnect re-enabled	–	3.7 to 109	–	µs
T _{AWAKE_GWE1}	Rising edge of the AWAKE pin until write-protect lock released on all writable clocked elements, using <i>sw_clk:InternalClock</i> and <i>sw_gwe_cycle:1</i> .	–	67	–	ns
T _{AWAKE_GWE512}	Rising edge of the AWAKE pin until write-protect lock released on all writable clocked elements, using <i>sw_clk:InternalClock</i> and <i>sw_gwe_cycle:512</i> .	–	14	–	µs
T _{AWAKE_GTS1}	Rising edge of the AWAKE pin until outputs return to the behavior described in the FPGA application, using <i>sw_clk:InternalClock</i> and <i>sw_gts_cycle:1</i> .	–	57	–	ns
T _{AWAKE_GTS512}	Rising edge of the AWAKE pin until outputs return to the behavior described in the FPGA application, using <i>sw_clk:InternalClock</i> and <i>sw_gts_cycle:512</i> .	–	14	–	µs

Notes:

1. These parameters based on characterization.
2. For information on using the Suspend feature, see [XAPP480: Using Suspend Mode in Spartan-3 Generation FPGAs](#).

Configuration and JTAG Timing

General Configuration Power-On/Reconfigure Timing

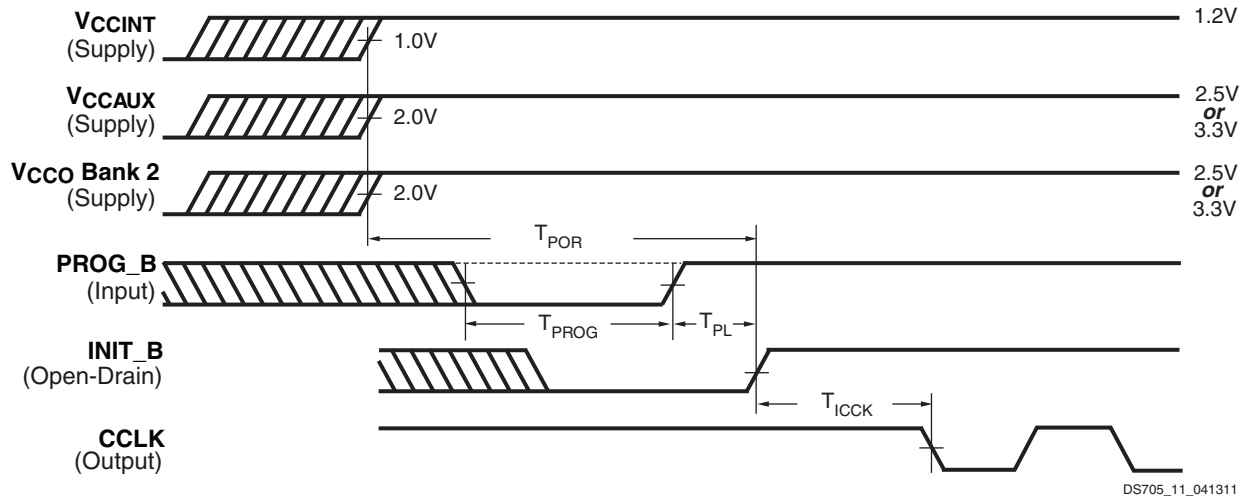

Notes:

1. The V_{CCINT} , V_{CCAUX} , and V_{CCO} supplies can be applied in any order.
2. The Low-going pulse on $PROG_B$ is optional after power-on.
3. The rising edge of $INIT_B$ samples the voltage levels applied to the mode pins ($M0 - M2$).

Figure 11: Waveforms for Power-On and the Beginning of Configuration

Table 46: Power-On Timing and the Beginning of Configuration

Symbol	Description	Device	Min	Max	Units
$T_{POR}^{(2)}$	The time from the application of V_{CCINT} , V_{CCAUX} , and V_{CCO} Bank 2 supply voltage ramps (whichever occurs last) to the rising transition of the $INIT_B$ pin	All	–	18	ms
T_{PROG}	The width of the low-going pulse on the $PROG_B$ pin	All	0.5	–	μ s
$T_{PL}^{(2)}$	The time from the rising edge of the $PROG_B$ pin to the rising transition on the $INIT_B$ pin	All	–	2	ms
T_{INIT}	Minimum Low pulse width on $INIT_B$ output	All	300	–	ns
$T_{ICCK}^{(3)}$	The time from the rising edge of the $INIT_B$ pin to the generation of the configuration clock signal at the $CCLK$ output pin	All	0.5	4	μ s

Notes:

1. The numbers in this table are based on the operating conditions set forth in Table 8. This means power must be applied to all V_{CCINT} , V_{CCO} , and V_{CCAUX} lines.
2. Power-on reset and the clearing of configuration memory occurs during this period.
3. This specification applies only to the SPI and BPI modes.
4. For details on configuration, see UG332, *Spartan-3 Generation Configuration User Guide*.

Configuration Clock (CCLK) Characteristics

Table 47: CCLK Output Period by *ConfigRate* Option Setting

Symbol	Description	<i>ConfigRate</i> Setting	Temperature Range	Minimum	Maximum	Units
T _{CCLK1}	CCLK clock period by <i>ConfigRate</i> setting	1 (power-on value)	I-Grade/ Q-Grade	1,180	2,500	ns
T _{CCLK3}		3	I-Grade/ Q-Grade	390	833	ns
T _{CCLK6}		6	I-Grade/ Q-Grade	195	417	ns
T _{CCLK7}		7	I-Grade/ Q-Grade	168	357	ns
T _{CCLK8}		8	I-Grade/ Q-Grade	147	313	ns
T _{CCLK10}		10	I-Grade/ Q-Grade	116	250	ns
T _{CCLK12}		12	I-Grade/ Q-Grade	97	208	ns
T _{CCLK13}		13	I-Grade/ Q-Grade	88	192	ns
T _{CCLK17}		17	I-Grade/ Q-Grade	68	147	ns
T _{CCLK22}		22	I-Grade/ Q-Grade	51	114	ns
T _{CCLK25}		25	I-Grade/ Q-Grade	45	100	ns
T _{CCLK27}		27	I-Grade/ Q-Grade	42	93	ns
T _{CCLK33}		33	I-Grade/ Q-Grade	34	76	ns
T _{CCLK44}		44	I-Grade/ Q-Grade	25	57	ns
T _{CCLK50}		50	I-Grade/ Q-Grade	21	50	ns
T _{CCLK100}	100	I-Grade/ Q-Grade	10.6	25	ns	

Notes:

1. Set the *ConfigRate* option value when generating a configuration bitstream.

Table 48: CCLK Output Frequency by ConfigRate Option Setting

Symbol	Description	ConfigRate Setting	Temperature Range	Minimum	Maximum	Units
F _{CCLK1}	Equivalent CCLK clock frequency by ConfigRate setting	1 (power-on value)	I-Grade/ Q-Grade	0.400	0.847	MHz
F _{CCLK3}		3	I-Grade/ Q-Grade	1.20	2.57	MHz
F _{CCLK6}		6	I-Grade/ Q-Grade	2.40	5.13	MHz
F _{CCLK7}		7	I-Grade/ Q-Grade	2.80	5.96	MHz
F _{CCLK8}		8	I-Grade/ Q-Grade	3.20	6.81	MHz
F _{CCLK10}		10	I-Grade/ Q-Grade	4.00	8.63	MHz
F _{CCLK12}		12	I-Grade/ Q-Grade	4.80	10.31	MHz
F _{CCLK13}		13	I-Grade/ Q-Grade	5.20	11.37	MHz
F _{CCLK17}		17	I-Grade/ Q-Grade	6.80	14.61	MHz
F _{CCLK22}		22	I-Grade/ Q-Grade	8.80	19.61	MHz
F _{CCLK25}		25	I-Grade/ Q-Grade	10.00	22.23	MHz
F _{CCLK27}		27	I-Grade/ Q-Grade	10.80	23.81	MHz
F _{CCLK33}		33	I-Grade/ Q-Grade	13.20	29.23	MHz
F _{CCLK44}		44	I-Grade/ Q-Grade	17.60	40.00	MHz
F _{CCLK50}		50	I-Grade/ Q-Grade	20.00	47.66	MHz
F _{CCLK100}	100	I-Grade/ Q-Grade	40.00	94.34	MHz	

Table 49: CCLK Output Minimum Low and High Time

Symbol	Description		ConfigRate Setting															Units	
			1	3	6	7	8	10	12	13	17	22	25	27	33	44	50		100
T _{MCCL} , T _{MCCH}	CCLK Minimum Low and High Time	I-Grade/ Q-Grade	560	185	92.6	79.8	69.8	55.0	46.0	41.8	32.3	24.2	21.4	20.0	16.2	11.9	10.0	5.0	ns

Table 50: CCLK Input Low and High Time

Symbol	Description	Min	Max	Units
T _{SCCL} , T _{SCCH}	CCLK Low and High time	5	∞	ns

Slave Serial Mode Timing

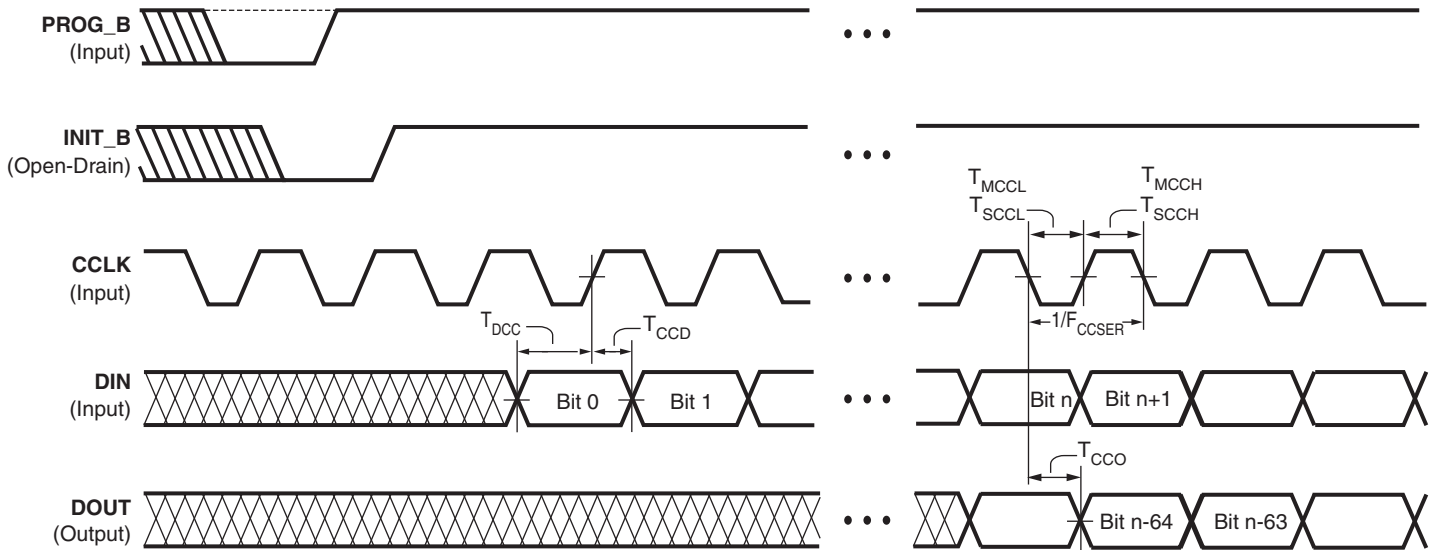

DS705_12_041311

Figure 12: Waveforms for Slave Serial Configuration

Table 51: Timing for the Slave Serial Configuration Modes

Symbol	Description	Min	Max	Units	
Clock-to-Output Times					
T_{CCO}	The time from the falling transition on the CCLK pin to data appearing at the DOUT pin	1.5	10	ns	
Setup Times					
T_{DCC}	The time from the setup of data at the DIN pin to the rising transition at the CCLK pin	7	–	ns	
Hold Times					
T_{CCD}	The time from the rising transition at the CCLK pin to the point when data is last held at the DIN pin	1.0	–	ns	
Clock Timing					
T_{CCH}	High pulse width at the CCLK input pin	See Table 50			
T_{CCL}	Low pulse width at the CCLK input pin	See Table 50			
F_{CCSER}	Frequency of the clock signal at the CCLK input pin	No bitstream compression	0	100	MHz
		With bitstream compression	0	100	MHz

Notes:

1. The numbers in this table are based on the operating conditions set forth in Table 8.
2. For serial configuration with a daisy-chain of multiple FPGAs, the maximum limit is 25 MHz.

Slave Parallel Mode Timing

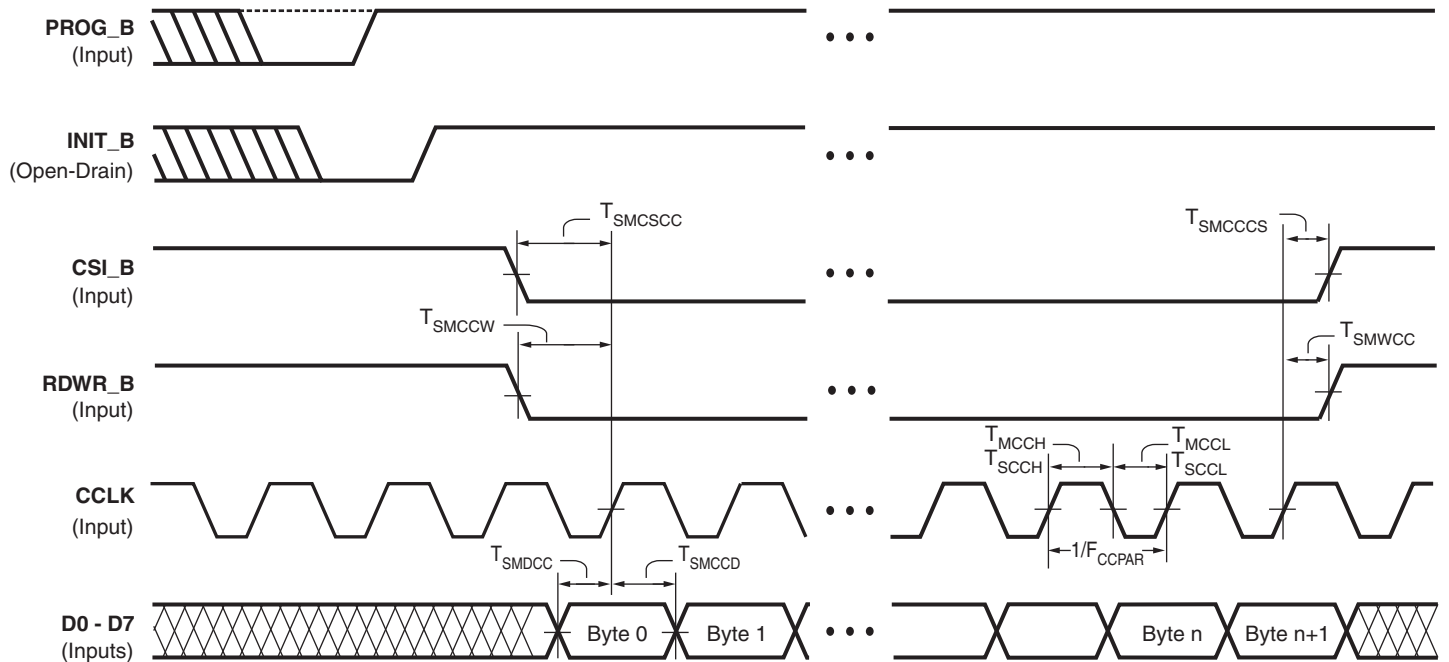

Notes:

1. It is possible to abort configuration by pulling CSI_B Low in a given CCLK cycle, then switching RDWR_B Low or High in any subsequent cycle for which CSI_B remains Low. The RDWR_B pin asynchronously controls the driver impedance of the D0 - D7 bus. When RDWR_B switches High, be careful to avoid contention on the D0 - D7 bus.
2. To pause configuration, pause CCLK instead of deasserting CSI_B. See the section in Chapter 7 called “Non-Continuous SelectMAP Data Loading” in [UG332](#) for more details.

Figure 13: Waveforms for Slave Parallel Configuration

Table 52: Timing for the Slave Parallel Configuration Mode

Symbol	Description	Min	Max	Units	
Setup Times					
$T_{SMDCC}^{(2)}$	The time from the setup of data at the D0-D7 pins to the rising transition at the CCLK pin	7	–	ns	
T_{SMCSCC}	Setup time on the CSI_B pin before the rising transition at the CCLK pin	7	–	ns	
T_{SMCCW}	Setup time on the RDWR_B pin before the rising transition at the CCLK pin	17	–	ns	
Hold Times					
T_{SMCCD}	The time from the rising transition at the CCLK pin to the point when data is last held at the D0-D7 pins	1	–	ns	
T_{SMCCCS}	The time from the rising transition at the CCLK pin to the point when a logic level is last held at the CSO_B pin	0	–	ns	
T_{SMWCC}	The time from the rising transition at the CCLK pin to the point when a logic level is last held at the RDWR_B pin	0	–	ns	
Clock Timing					
T_{CCH}	The High pulse width at the CCLK input pin	5	–	ns	
T_{CCL}	The Low pulse width at the CCLK input pin	5	–	ns	
F_{CCPAR}	Frequency of the clock signal at the CCLK input pin	No bitstream compression	0	80	MHz
		With bitstream compression	0	80	MHz

Notes:

1. The numbers in this table are based on the operating conditions set forth in [Table 8](#).
2. Some Xilinx documents refer to Parallel modes as “SelectMAP” modes.

Serial Peripheral Interface Configuration Timing

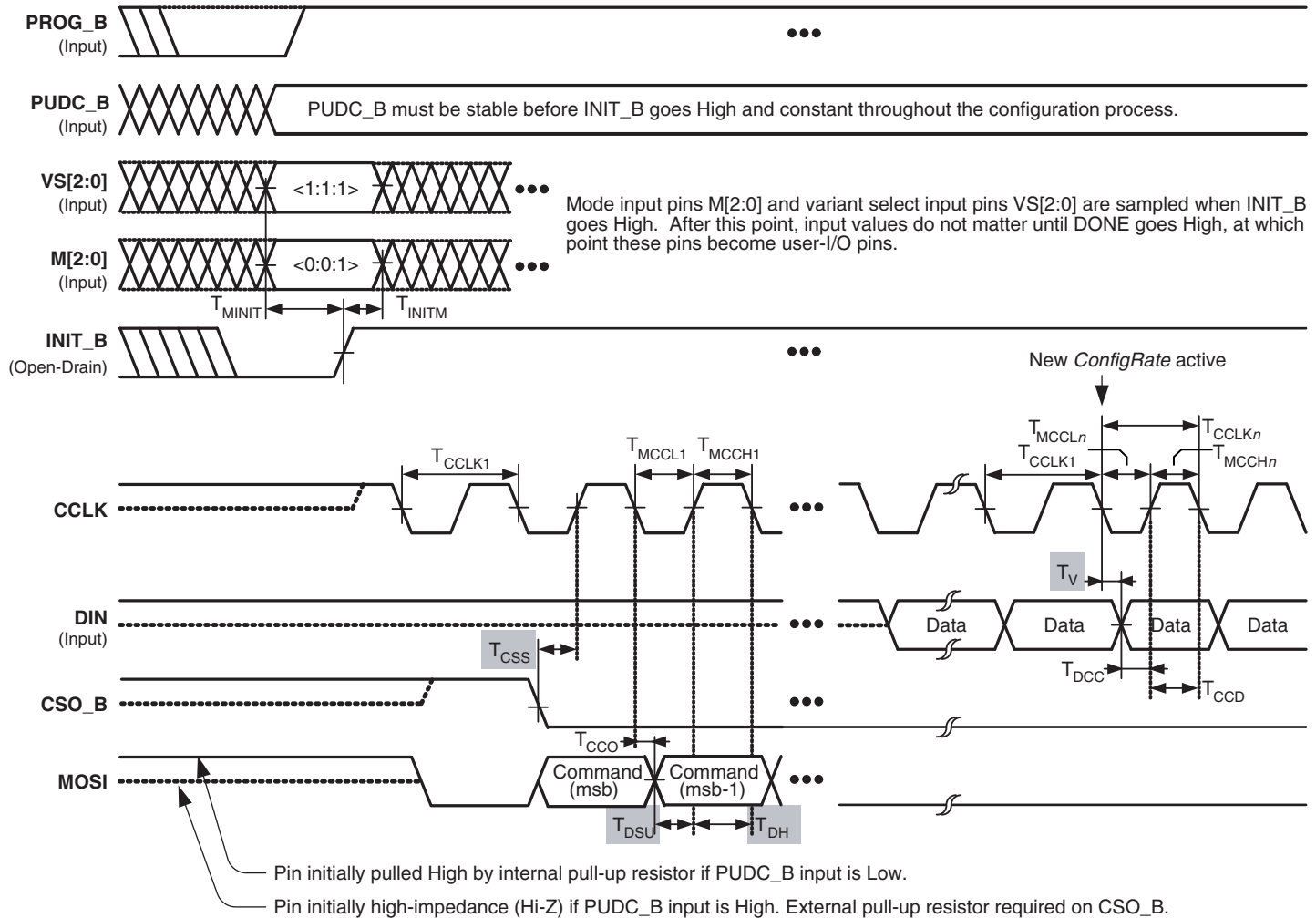

Shaded values indicate specifications on attached SPI Flash PROM.

DS705_14_041311

Figure 14: Waveforms for Serial Peripheral Interface Configuration

Table 53: Timing for Serial Peripheral Interface Configuration Mode

Symbol	Description	Minimum	Maximum	Units
T_{CCLK1}	Initial CCLK clock period	See Table 47		
T_{CCLKn}	CCLK clock period after FPGA loads ConfigRate setting	See Table 47		
T_{MINIT}	Setup time on VS[2:0] variant-select pins and M[2:0] mode pins before the rising edge of INIT_B	50	-	ns
T_{INITM}	Hold time on VS[2:0] variant-select pins and M[2:0] mode pins after the rising edge of INIT_B	0	-	ns
T_{CCO}	MOSI output valid delay after CCLK falling edge	See Table 51		
T_{DCC}	Setup time on DIN data input before CCLK rising edge	See Table 51		
T_{CCD}	Hold time on DIN data input after CCLK rising edge	0	-	ns

Table 54: Configuration Timing Requirements for Attached SPI Serial Flash

Symbol	Description	Requirement	Units
T_{CCS}	SPI serial Flash PROM chip-select time	$T_{CCS} \leq T_{MCCL1} - T_{CCO}$	ns
T_{DSU}	SPI serial Flash PROM data input setup time	$T_{DSU} \leq T_{MCCL1} - T_{CCO}$	ns
T_{DH}	SPI serial Flash PROM data input hold time	$T_{DH} \leq T_{MCCH1}$	ns
T_V	SPI serial Flash PROM data clock-to-output time	$T_V \leq T_{MCCLn} - T_{DCC}$	ns
f_C or f_R	Maximum SPI serial Flash PROM clock frequency (also depends on specific read command used)	$f_C \geq \frac{1}{T_{CCLKn(min)}}$	MHz

Notes:

1. These requirements are for successful FPGA configuration in SPI mode, where the FPGA generates the CCLK signal. The post-configuration timing can be different to support the specific needs of the application loaded into the FPGA.
2. Subtract additional printed circuit board routing delay as required by the application.

Byte Peripheral Interface Configuration Timing

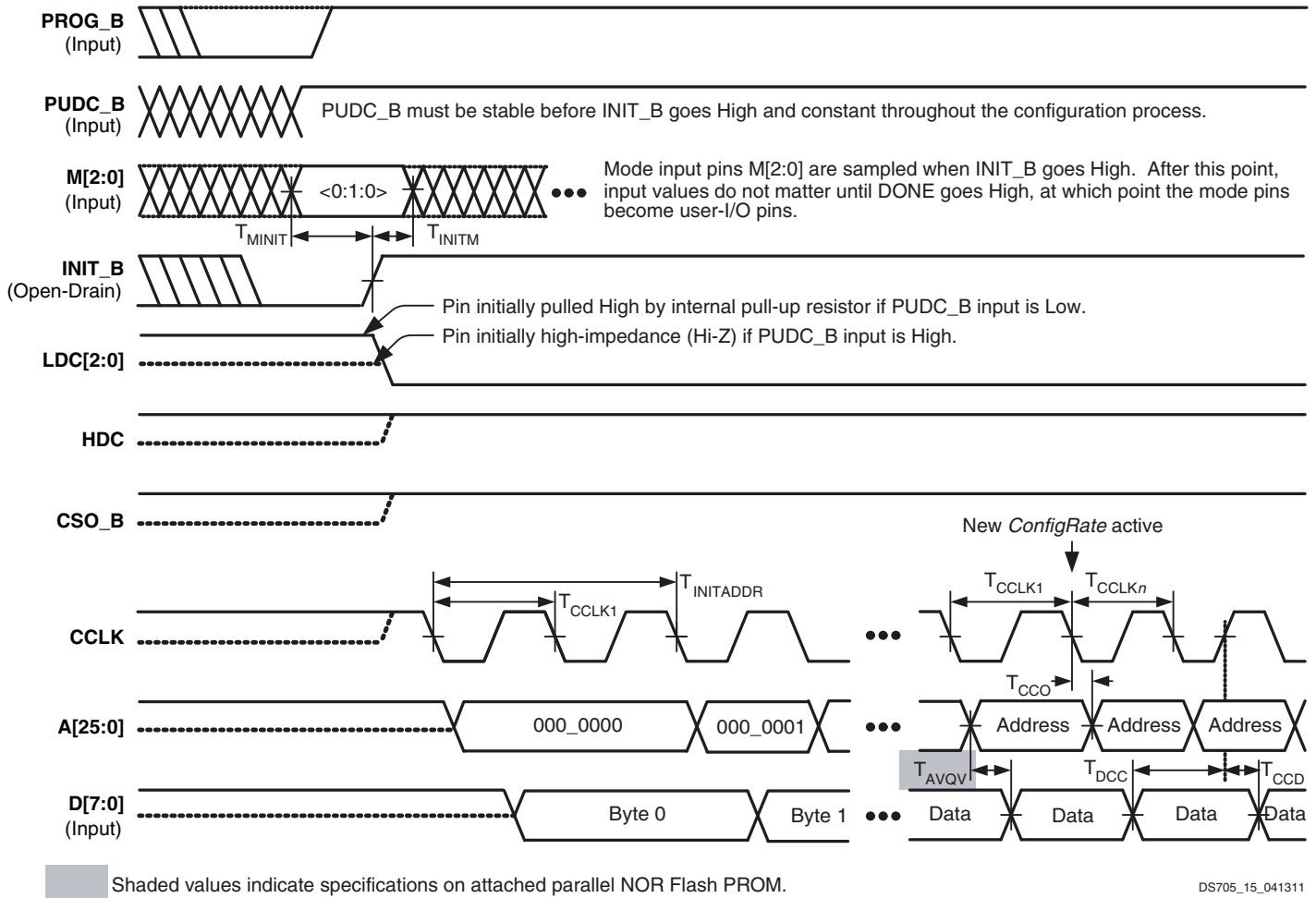

Figure 15: Waveforms for Byte-wide Peripheral Interface Configuration

Table 55: Timing for Byte-wide Peripheral Interface Configuration Mode

Symbol	Description	Minimum	Maximum	Units
T_{CCLK1}	Initial CCLK clock period	See Table 47		
T_{CCLKn}	CCLK clock period after FPGA loads ConfigRate setting	See Table 47		
T_{MINIT}	Setup time on M[2:0] mode pins before the rising edge of INIT_B	50	–	ns
T_{INITM}	Hold time on M[2:0] mode pins after the rising edge of INIT_B	0	–	ns
$T_{INITADDR}$	Minimum period of initial A[25:0] address cycle; LDC[2:0] and HDC are asserted and valid	5	5	T_{CCLK1} cycles
T_{CCO}	Address A[25:0] outputs valid after CCLK falling edge	See Table 51		
T_{DCC}	Setup time on D[7:0] data inputs before CCLK rising edge	See T_{SMDCC} in Table 52		
T_{CCD}	Hold time on D[7:0] data inputs after CCLK rising edge	0	–	ns

Table 56: Configuration Timing Requirements for Attached Parallel NOR Flash)

Symbol	Description	Requirement	Units
T_{CE} (t_{ELQV})	Parallel NOR Flash PROM chip-select time	$T_{CE} \leq T_{INITADDR}$	ns
T_{OE} (t_{GLQV})	Parallel NOR Flash PROM output-enable time	$T_{OE} \leq T_{INITADDR}$	ns
T_{ACC} (t_{AVQV})	Parallel NOR Flash PROM read access time	$T_{ACC} \leq 50\% T_{CCLKn(min)} - T_{CCO} - T_{DCC} - PCB$	ns
T_{BYTE} (t_{FLQV}, t_{FHQV})	For x8/x16 PROMs only: BYTE# to output valid time ⁽³⁾	$T_{BYTE} \leq T_{INITADDR}$	ns

Notes:

1. These requirements are for successful FPGA configuration in BPI mode, where the FPGA generates the CCLK signal. The post-configuration timing can be different to support the specific needs of the application loaded into the FPGA.
2. Subtract additional printed circuit board routing delay as required by the application.
3. The initial BYTE# timing can be extended using an external, appropriately sized pull-down resistor on the FPGA's LDC2 pin. The resistor value also depends on whether the FPGA's PUDC_B pin is High or Low.

IEEE 1149.1/1532 JTAG Test Access Port Timing

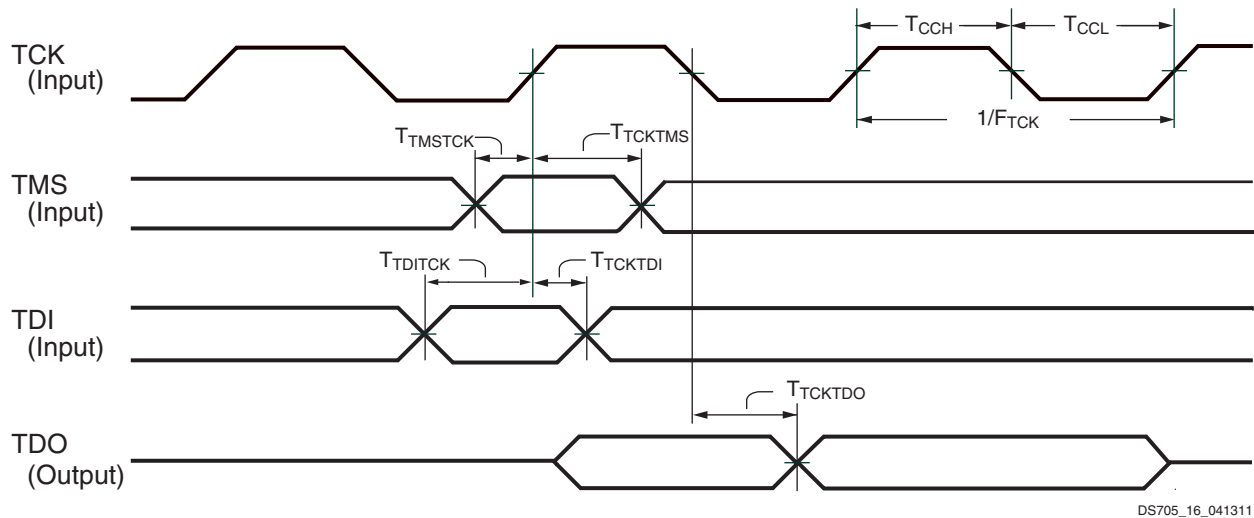

Figure 16: JTAG Waveforms

Table 57: Timing for the JTAG Test Access Port

Symbol	Description	Min	Max	Units		
Clock-to-Output Times						
T_{TCKTDO}	The time from the falling transition on the TCK pin to data appearing at the TDO pin	1.0	11.0	ns		
Setup Times						
T_{TDITCK}	The time from the setup of data at the TDI pin to the rising transition at the TCK pin	All functions except those shown below	7.0	–	ns	
		Boundary-Scan commands (INTEST, EXTEST, SAMPLE)	13.0			
T_{TMSTCK}	The time from the setup of a logic level at the TMS pin to the rising transition at the TCK pin	7.0	–	ns		
Hold Times						
T_{TCKTDI}	The time from the rising transition at the TCK pin to the point when data is last held at the TDI pin	All functions except those shown below	0	–	ns	
		Configuration commands (CFG_IN, ISC_PROGRAM)	3.5			
T_{TCKTMS}	The time from the rising transition at the TCK pin to the point when a logic level is last held at the TMS pin	0	–	ns		
Clock Timing						
T_{CCH}	The High pulse width at the TCK pin	All functions except ISC_DNA command		5	–	ns
T_{CCL}	The Low pulse width at the TCK pin			5	–	ns
T_{CCHDNA}	The High pulse width at the TCK pin	During ISC_DNA command		10	10,000	ns
T_{CCLDNA}	The Low pulse width at the TCK pin			10	10,000	ns
F_{TCK}	Frequency of the TCK signal	BYPASS or HIGHZ instructions		0	33	MHz
		All operations except for BYPASS or HIGHZ instructions			20	

Notes:

1. The numbers in this table are based on the operating conditions set forth in Table 8.
2. For details on JTAG, see “JTAG Configuration Mode and Boundary-Scan” in Chapter 9 of UG332, Spartan-3 Generation Configuration User Guide.

Revision History

The following table shows the revision history for this document.

Date	Version	Description
07/10/08	1.0	Initial Xilinx release.
01/20/09	1.1	Updated Features and Key Feature Differences from Commercial XC Devices . Removed MultiBoot description from Configuration . Updated Note 2 in Figure 11 . Updated T_{ACC} requirement in Table 56 .
04/18/11	2.0	This revision goes along with XCN11019: Data Sheet Revisions for Xilinx Automotive (XA) Spartan-3A/-3A DSP FPGA Devices . Added I_{IK} to Table 4 . Updated description for V_{IN} in Table 8 including adding Note 4. Also, added Note 2 to I_L in Table 9 to note potential leakage between pins of a differential pair. Updated Notes 5 and 6 in Table 13 . Table 20 : Updated tags to Note 3. In Table 44 , corrected symbols for T_{DNACKH} and T_{DNACKL} . Corrected symbols for $T_{SUSPEND_GTS}$ and $T_{SUSPEND_GWE}$ in Table 45 . Revised standard title to: IEEE 1149.1/1532 JTAG Test Access Port Timing . Updated Notice of Disclaimer .

Notice of Disclaimer

The information disclosed to you hereunder (the “Materials”) is provided solely for the selection and use of Xilinx products. To the maximum extent permitted by applicable law: (1) Materials are made available “AS IS” and with all faults, Xilinx hereby DISCLAIMS ALL WARRANTIES AND CONDITIONS, EXPRESS, IMPLIED, OR STATUTORY, INCLUDING BUT NOT LIMITED TO WARRANTIES OF MERCHANTABILITY, NON-INFRINGEMENT, OR FITNESS FOR ANY PARTICULAR PURPOSE; and (2) Xilinx shall not be liable (whether in contract or tort, including negligence, or under any other theory of liability) for any loss or damage of any kind or nature related to, arising under, or in connection with, the Materials (including your use of the Materials), including for any direct, indirect, special, incidental, or consequential loss or damage (including loss of data, profits, goodwill, or any type of loss or damage suffered as a result of any action brought by a third party) even if such damage or loss was reasonably foreseeable or Xilinx had been advised of the possibility of the same. Xilinx assumes no obligation to correct any errors contained in the Materials or to notify you of updates to the Materials or to product specifications. You may not reproduce, modify, distribute, or publicly display the Materials without prior written consent. Certain products are subject to the terms and conditions of the Limited Warranties which can be viewed at <http://www.xilinx.com/warranty.htm>; IP cores may be subject to warranty and support terms contained in a license issued to you by Xilinx. Xilinx products are not designed or intended to be fail-safe or for use in any application requiring fail-safe performance; you assume sole risk and liability for use of Xilinx products in Critical Applications: <http://www.xilinx.com/warranty.htm#critapps>.

Automotive Applications Disclaimer

XILINX PRODUCTS ARE NOT DESIGNED OR INTENDED TO BE FAIL-SAFE, OR FOR USE IN ANY APPLICATION REQUIRING FAIL-SAFE PERFORMANCE, SUCH AS APPLICATIONS RELATED TO: (I) THE DEPLOYMENT OF AIRBAGS, (II) CONTROL OF A VEHICLE, UNLESS THERE IS A FAIL-SAFE OR REDUNDANCY FEATURE (WHICH DOES NOT INCLUDE USE OF SOFTWARE IN THE XILINX DEVICE TO IMPLEMENT THE REDUNDANCY) AND A WARNING SIGNAL UPON FAILURE TO THE OPERATOR, OR (III) USES THAT COULD LEAD TO DEATH OR PERSONAL INJURY. CUSTOMER ASSUMES THE SOLE RISK AND LIABILITY OF ANY USE OF XILINX PRODUCTS IN SUCH APPLICATIONS.

X-ON Electronics

Largest Supplier of Electrical and Electronic Components

Click to view similar products for [FPGA - Field Programmable Gate Array](#) category:

Click to view products by [Xilinx](#) manufacturer:

Other Similar products are found below :

[5AGXMA3D4F27I3N](#) [EP1S10F672C7](#) [EP1S20F672I7N](#) [EP1SGX25DF672I6N](#) [EP2S30F672C5](#) [EP2S60F672C5N](#) [PLUS16L87N](#)
[PLUS16R67N](#) [PLUS20L87N](#) [PLUS20R87N](#) [5AGXBA5D6F27C6N](#) [5AGXMA5D6F27C6N](#) [EP1S20F672C7N](#) [EP1SGX25DF672I6](#)
[EP20K300EFI672-2X](#) [EP2S15F672C3N](#) [QP82S100/BXA](#) [LCMXO640C-3FT256CAHW](#) [5962-9154507MXA](#) [EPF10K200SFI672-2B](#) [5962-](#)
[9154503MQA](#) [EPF10K50EQC240-1N](#) [EP1S10F672C7N](#) [ICE40UL1K-SWG16ITR1K](#) [ICE5LP4K-SWG36ITR1K](#) [ICE40UL640-](#)
[SWG16ITR1K](#) [ICE40LP1K-SWG16TR1K](#) [ICE40LP640-SWG16TR1K](#) [GW1NR-LV9MG100PC6/I5](#) [GW1N-LV4CS72C6/I5](#) [GW1NR-](#)
[UV4MG81PC6/I5](#) [GW1N-LV9UG332C6/I5](#) [GW1NR-LV4MG81PC6/I5](#) [GW1NZ-LV1CS16C6/I5](#) [GW1NR-LV9QN88PC6/I5](#) [GW1N-](#)
[LV4MG160C6/I5](#) [GW1NR-UV4QN88C6/I5](#) [GW1N-UV4MG160C6/I5](#) [GW1NR-UV9QN88PC6/I5](#) [GW1NR-LV9LQ144PC6/I5](#) [GW1N-](#)
[UV9MG160C6/I5](#) [EP2AGX45CU17I5G](#) [M2GL050-FGG896I](#) [AGLP125V5-CSG289](#) [M2GL050-FGG484](#) [APA150-BG456I](#) [A3P400-](#)
[FGG484](#) [A54SX32A-BG329I](#) [M2GL050-FGG484](#) [ICE40UL1K-CM36AITR1K](#)