

4020幻彩 贴片式发光二极管



特点 (characteristic) :

- * 外观尺寸 (L/W/H) :3.95*1.95*1.7mm
Appearance dimension (L / w / h): 3.95 x 1.95 x 1.7 mm
- * 发光颜色及胶体: 全彩/半透明雾状胶体
Luminous color and colloid: Full color / translucent fog colloid
- * 4020灯珠内部集成高质量外控单线级联恒流IC(IC内置滤波器件, 增强其信号抗干扰能力), 优质RGB LED芯片, 体积小, 外围简单
The 4020 ball interior integrates high-quality external single-line cascade current IC(IC built-in filter device, enhances its signal anti-jamming ability), high-quality RGB LED chip, compact size, and simple periphery.
- * 内置N302B6恒流精度高, 内部RGB芯片预先分光处理; 发光高度一致, 白光效果纯正
The built-in N302B7 constant current has high accuracy and the internal RGB chip is pre-spectroscopic. The luminous height is the same, and the white light effect is pure.
- * 整形转发强化技术, 单线数据传输, 可无限级联
Plastic forwarding enhancement technology, single-line data transmission, can be cascaded.
- * 数据传输频率800Kbps/秒, 可实现画面刷新速率30帧/秒时, 不小于1024点
The data transmission frequency is 800Kbps per second, and the screen refresh rate can be achieved at 30 frames per second, not less than 1024 points.
- * 输出端口PWM控制能够实现256级灰度调节, 端口扫描频率1.5KHz/s
The output port PWM control can achieve 256 levels of grayscale adjustment, and the port scan frequency is 1.5 KHz / S.
- * 采用优化预置12mA/通道恒流模式, 低压驱动级联数量最大化; 高恒流精度, 片内误差<1.5%, 片间误差<3%
Optimized preset 12mA / channel constant current mode is adopted to maximize the number of low-voltage drive cascades. High constant current accuracy, intraslice error & lt; 1.5 %, interslice error & lt; 3 %.
- * 内置低压强化模块, VDD在2.7V以上100%正常工作
The built-in low-pressure reinforcement module, VDD is 100 % normal above 2.7 V.
- * 超强数据整形能力: 接受完本单元数据自动将后续数据整形输出
Super data shaping ability: accept this unit data automatically will follow the data shaping output.
- * 环保产品, 符合ROHS要求
Environmental protection products meet ROHS requirements

产品概述 (Product Overview) :

N302B6-4020RGB是一款集成高质量单线级联恒流驱动IC N302B7和高质量RGB LED芯片的外控恒流4020集成灯珠。其中内置控制IC N302B6具有高可靠，低功耗，抗干扰性能高和恒流精度高的特点，而内部集成优选高质量的LED芯片，具有发光一致性优良，白光效果纯正，光衰小的优点。N302B6-4020RGB将2者优点相结合，同时带来体积小，外围元件少，版面干净的特点。通过外部控制器控制，可展现幻彩，动画以及高标准视频效果。

N302B6-4020RGB is an externally controlled constant current 4020 integrated bead that integrates high-quality single-line cascade current drive IC N302B6 and high-quality RGB LED chips. Among them, the built-in control IC N302B6 has the characteristics of high reliability, low power consumption, and high anti-interference performance. The internal integration of high-quality LED chips has the advantages of excellent luminous consistency, pure white light effect, and low light decay. N302B6-4020RGB combines the advantages of 2 people with the characteristics of small size, few peripheral components, and clean layout. Through the external controller control, can show the color, animation and high standard video effects.

应用领域 (product application) :

- * 3C产品 (计算机, 异形屏、通讯和消费电子)
3C products (computer, special-shaped screen, communication and consumer electronics)
- * 装饰、外观照明 (全彩灯条、模组、点光源)
Decoration and appearance lighting (full-color light strip, module, point light source)



.....

目录

Catalogue

电性参数
Electrical Characteristics.....4

功能说明
Description of functions.....6

典型特性曲线
Typical Characteristic Curves.....8

外形尺寸
Outline Dimensions.....9

包装
Packaging.....10

焊接指导
Guideline for Soldering.....12

使用注意事项
Precautions.....14

电性参数

Electrical Characteristics

◇极限参数（温度=25℃）：

项目 Item	符号 Symbol	最大额定值 Absolute Maximum Rating	单位 Unit
逻辑电源电压Logic supply voltage	Vdd	6.5	mA
输出端口耐压 Output port withstand voltage	Vout	24	mA
逻辑输入电压Logic input voltage	Vi	-0.5 ~ Vdd + 0.5	V
工作温度Operating Temperature	Topr	-40 ~ +85	℃
贮藏温度Storage Temperature	Tstg	-55 ~ +150	℃

推荐工作范围（如无特殊说明，Ta = -40 ~ +85℃，Vss = 0V）/Recommended scope of work (Ta = -40 ~ +85℃, Vss = 0V without special description):

参数名称 Parameter	符号 Symbol	最小 Min	典型 Typ	最大 Max	单位 Unit	测试条件 Test conditions
逻辑电源电压Logic supply voltage	Vdd	-	5.2	6.5	V	-
高电平输入电压High level input voltage	Vih	0.65Vdd	-	Vdd	V	-
低电平输入电压Low level input voltage	Vil	0	-	0.3Vdd	V	-
输出端口耐压 Output port withstand voltage	Vout	24	-		V	-
PWM 频率 PWM frequency			1.5		KHz	-

内置LED参数

Built-in LED parameters:

发光颜色 Luminous color	主波长 (nm) Main wavelength	发光强度 (mcd) Luminous intensity	工作电流 (mA) Working current	工作电压 (V) Working voltage
R	620-625	500-600	20	2.0-2.2
G	520-525	2000-2400	20	3.0-3.3
B	465-470	240-300	20	3.0-3.3

光电参数 (温度=25°C) :

Electro-Optical Characteristics (Temperature=25°C):

参数名称 Parameter	符号 Symbol	最小 Min	典型 Typ	最大 Max	单位 Unit	测试条件 Test conditions
低电平输出电流 Low level output current	Iout	-	12	-	mA	R, G, B
低电平输出电流 Low level output current	Ido	10	-	-	mA	Vo = 0.4V, Dout
输入电流 Input current	Ii	-	-	±1	µA	-
输出管脚电流 Output pin current	Isink	-	12	-	mA	-
高电平输入电压 High level input voltage	Vih	0.7 Vdd	-	-	V	DIN, SET
低电平输入电压 Low level input voltage	Vil	-	-	0.3 Vdd	V	DIN, SET
滞后电压 Hysteresis voltage	Vh	-	0.35	-	V	DIN, SET
电流偏移量 (通道间) Current offset (between channels)	dIout	-	±1.5	±3.0	%	Vds=1V, Iout=12mA
电流偏移量 (芯片间) Current offset (between chips)	dIout	-	±3.0	±5.0	%	Vds=1V, Iout=12mA
电流偏移量 VS-Vds Current offset VS VDS	%dVds	-	±0.1	±5.0	%/V	1V<Vds<3V
电流偏移量 VS-Vdd Current offset VS VDD	%dVds	-	±1.0	±2.0	%/V	4.5V<Vdd<5.5V
动态电流损耗 Dynamic current loss	IDDdyn	无负载	-	1	mA	
消耗功率 Power consumption	PD	-	-	250	mW	Ta=25°C
热阻值 Thermal resistance value	Rth(j-a)	-	80	190	°C/W	

开关特性 如无特殊说明, Ta = -40 ~ +85 °C, Vss = 0V, Vdd = 4.5 ~ 5.5V) /Switching characteristics:(Without special instructions, Ta = -40 ~ +85 °C, Vss = 0V, Vdd = 4.5~5.5V)

参数名称 Parameter	符号 Symbol	最小 Min	典型 Typ	最大 Max	单位 Unit	测试条件 Test conditions
振荡频率 Oscillation frequency	FOSC1	-	800	-	KHz	Vdd = 5V
	FOSC2	-	10	-	MHz	Vdd = 5V
传输延迟时间 Transmission delay time	Tflzl	-	160	300	ns	Cl = 15 pF, DIN → DOUT, Rl = 10 kΩ
下降时间 Descent time	Tthz	-	-	120	µs	Cl = 300 pF, OUTR/OUTG/OUTB
数据传输率 Data transmission rate	Fd	800	-	-	Kbps	占空比 50%
输入电容 Input capacitance	Ci	-	-	15	pF	-

亮度分档:

Brightness grading:

代码 Code	最小值 Minimum value	最大值 Maximum	单位 Company	测试条件 Test conditions
A04	2.0	2.2	mcd	IF=5mA
U05	3.0	3.3		

备注:光强误差± 11%

Remarks: light intensity error ± 11%

电压分档:

Voltage grading:

代码 Code	最小值 Minimum value	最大值 Maximum	单位 Company	测试条件 Test conditions
P04	500	600	V	IF=5mA
Z06	2000	2400		
T57	240	300		

备注:正向电压误差± 0.02V

Remarks: forward voltage error ± 0.02v

波长分档:

Wavelength division:

代码 Code	最小值 Minimumvalue	最大值 Maximum	单位 Company	测试条件 Test conditions
HR02	620	625	nm	IF=5mA
HG24	520	525		
HB34	465	470		

备注: 波长误差± 1 nm

Remarks: wavelength error ± 1 nm

功能说明 (1) Description of functions (1)

N302B6-4020RGB灯珠采用单线通讯方式，采用归零码的方式发送信号。芯片在上电复位以后，接收DIN端打来的数据，接收够24bit后，DO端口开始转发数据，供下一个芯片提供输入数据。在转发之前，DO口一直拉低。此时灯珠将不接收新的数据，内置RGB芯片根据接收到的24bit数据后产生的不同占空比信号，展现不同亮度。如果DIN端输入信号为RESET信号，芯片将接收到的数据送显示，芯片将在该信号结束后重新接收新的数据，在接收完开始的24bit数据后，通过DO口转发数据，灯珠在没有接收到RESET码前，RGB亮度保持不变，当接收到100us以上低电平RESET码后，灯珠内部RGB芯片将根据刚才接收到的24bit数据后产生的不同占空比信号，展现不同亮度。

N302B6-4020rgb lamp beads use single-line communication, using zero-return code to send signals. After the reset, the chip receives the data from Din. After receiving 24 bits, the DO begins to transmit the data for the next chip to provide input data. Do mouth pulled down until retweeted. At this point will not receive new data, BUILT-IN RGB chip according to the received 24 bit data generated by the duty cycle signal, display different brightness. If Din input signal is RESET signal, the chip will receive the data sent display, the chip will receive the new data after the end of the signal, after receiving the initial 24 bit data, the data will be transmitted through the DO port Before receiving the Reset Code, the RGB brightness remains the same. After receiving the low level RESET code above 100us, the RGB chip inside the lamp will display different brightness according to the different duty cycle signal generated after receiving the 24bit data just now.

(1) 芯片级联方法 Chip cascading method:



(2) 数据传输 Data transmission:

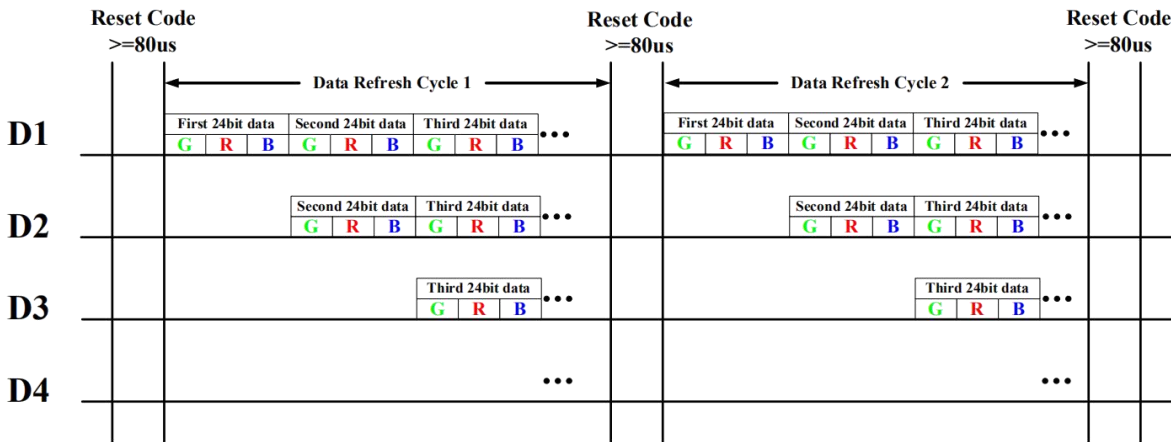

注：其中D1为MCU端发送的数据，D2、D3、D4为级联电路自动整形转发的数

Note: Where D1 is the data sent by the MCU, D2, D3, and D4 are the data automatically transferred by the cascading circuit.

功能说明 (2)

Description of functions (2)

(3) 24bit数据结构 24 bit data structure:



(4) 时序波形图 Sequential wave map:

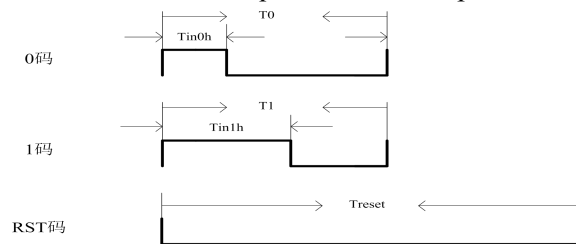

(5) 信号传输定义 Signal Transmission Definition:

参数Parameter	符号Symbol	最小值Min	典型值Typ	最大值Max	单位Unit
输入0码高电平时间Input 0 code high level time	Tin0h	0.20	0.28	0.35	us
输入1码高电平时间Input 1 code high level time	Tin1h	0.65	0.9	1.0	us
输入0码低电平时间Input 0 code low level time	T0L	1.55	1.72	30	us
输入1码低电平时间Input 1 code low level time	T1L	1.10	1.10	30	us
0码/1码周期0 code / 1 code cycle	T0/T1	1.75	-	35	us
RESET码低电平时间Reset code low level time	Treset	100	150	-	us

注/Note:

a: 4020RGB主要根据高电平时间判断“0”码和“1”码。高电平时间介于200ns~410ns, IC判断为“0”码, 高电平时间介于640ns~1000ns, 判断为“1”码。“0”码和“1”码的低电平代表此码结束, 准备接收下一数据码。/a: 4020RGB is mainly based on high-voltage flat time to determine "0" code and "1" code. The high power level time is between 200ns ~ 410ns, IC is judged to be "0" code, high power level time is between 640ns ~ 1000ns, and it is judged to be "1" code. The low levels of the "0" code and the "1" code represent the end of this code and are ready to receive the next data code.

b: 低电平复位时间最小为100us, 为了留有裕度, 一帧数据传输过程中(包括24bit和24bit之间、bit和bit之间)不要中断超过35us, 否则可能会被IC认为是RESET。中断时间在35us之内, 控制器可以进行正常数据传输等其他操作。/b: The low flat reset time is a minimum of 100us. In order to leave a margin, do not interrupt more than 35us during a frame data transmission(including between 24bit and 24bit, between bit and bit), otherwise it may be considered by IC as RESET. The interrupt time is within 35us, and the controller can perform other operations such as normal data transmission.

(6) 控制器时序建议值 Recommended Controller Timing:

描述Describe	参数项Parameter item	最小Min	典型Typ	最大Max	单位Unit
码元周期 Symbol period	T_data	1.2	1.25	-	us
0码高电平时间0 code high level time	T0H	0.2	0.32	0.4	us
0码低电平时间0 code low level time	T0L	0.8	0.93	-	us
1码高电平时间1 code high level time	T1H	0.62	0.64	1	us
1码低电平时间1 code low level time	T1L	0.2	0.61	-	us
RESET码低电平时间Reset code low level time	Tres	80	-	-	us

曲型特效曲线

Typical special effect curve

1. 恒流曲线 Constant current curve

N302B6-4020RGB 内置N302B6 IC恒流特性优异，通道间甚至芯片间的电流差异极小。

The N302B6-3921RGB built-in N302B6 IC has excellent constant current characteristics, and the current difference between channels and even between chips is minimal.

(1)：通道间的最大电流误差小于±1.5%，而芯片间的最大电流误差小于±3%。

The maximum current error between channels is less than ±1.5% , and the maximum current error between chips is less than ±3%.

(2)：当负载端电压发生变化时，输出电流不受影响，如下图所示

When the voltage at the load end changes, the output current is not affected, as shown in the figure below:

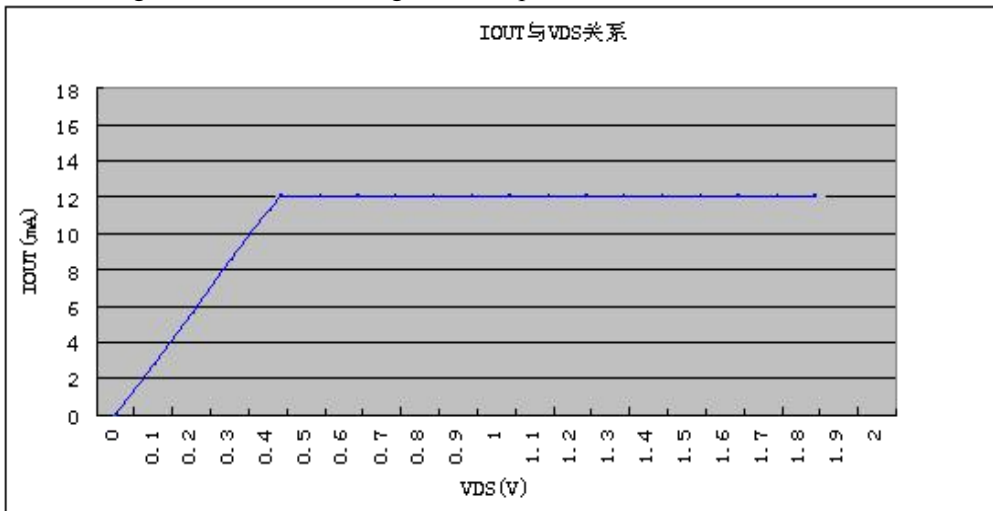

2. 应用线路图 Application Route Diagram:

电源电压5V(如图所示) Power Supply Voltage 5V (as shown in the figure)

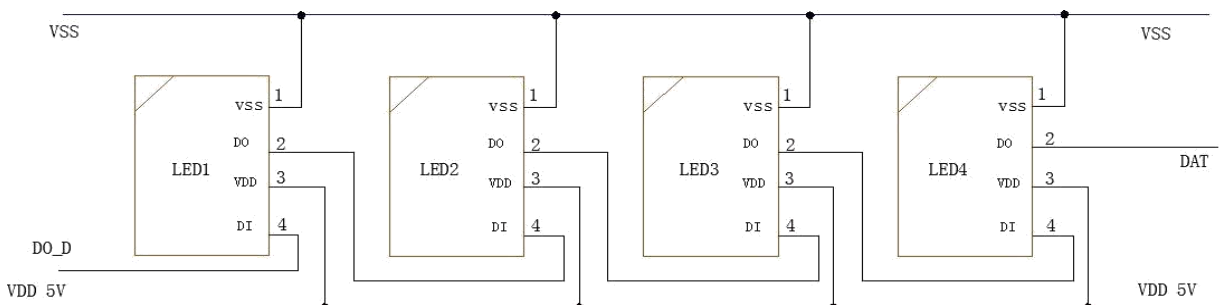

产品应用中驱控灯珠级联数量及控制器参数配置、驱动电源品质均有较大差异，故请在批量使用N302B6-4020RGB产品前，客户方务必自行验证产品兼容性，威能不承诺满足客户所有应用需求。/There are great differences in the number of drive lights and the configuration of controller parameters and the quality of drive power supply in product applications. Therefore, before using the N302B6-4020RGB product in bulk, the customer must verify the product compatibility. Power does not promise to meet all customer application requirements.

外形尺寸

Outline Dimension

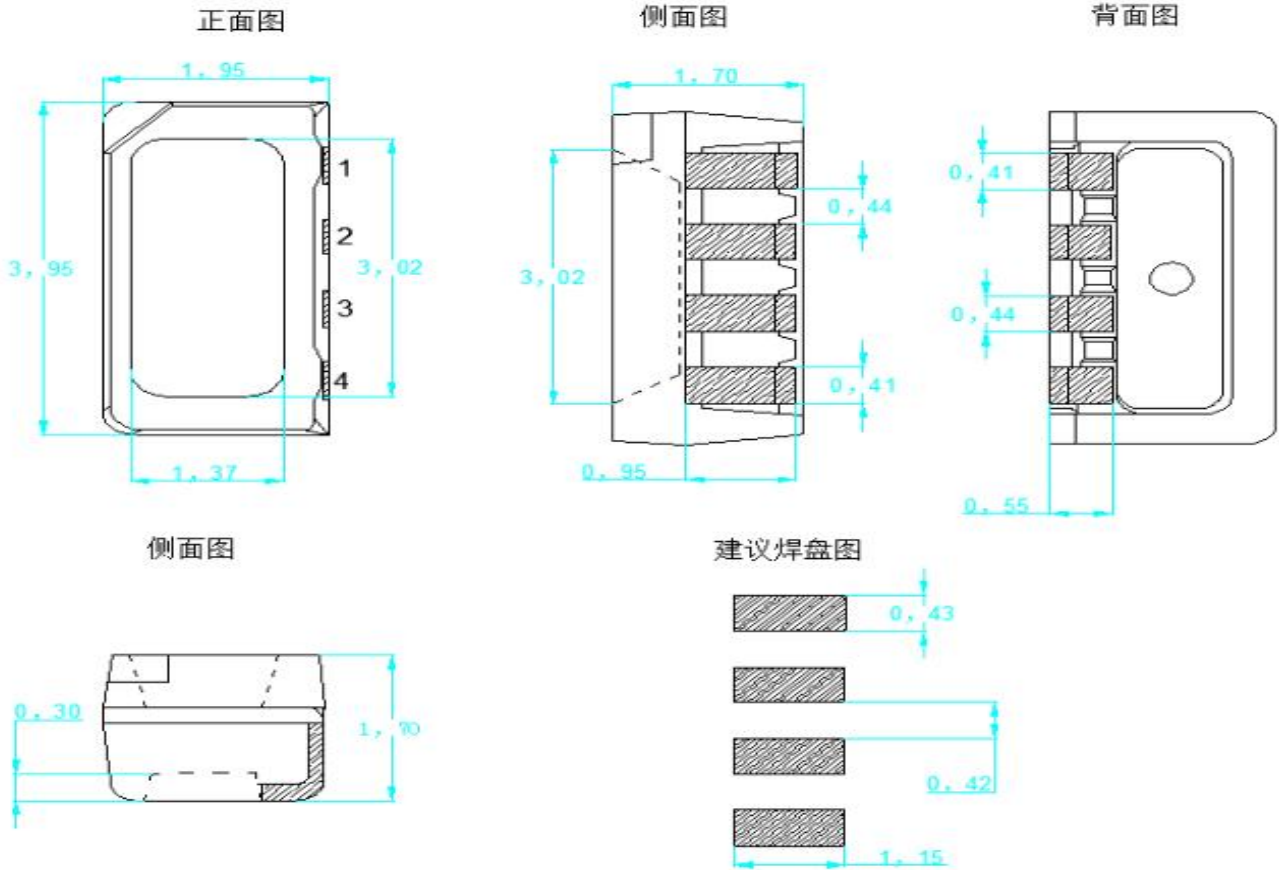

注: 1. 单位 : 毫米 (mm) Unit: mm
 2. 公差 : 如无特别标注则为± 0.1 mm Tolerances: ± 0.1 mm if unmarked.

脚位图 (4PIN) /Foot map(4PIN):

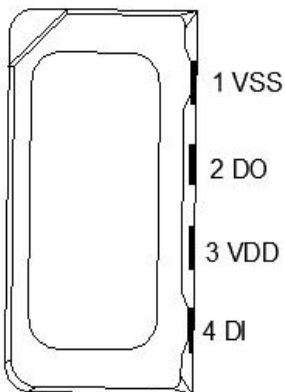

序号 Number	符号Symbol	功能描述 Function description
1	VSS	信号地及电源地Signal ground and power ground
2	DO	显示数据级联输出 (800K) Display data cascade output (800K)
3	VDD	内部N302B7电源正及RGB正Internal n302b7 power supply positive and RGB positive
4	DI	显示数据输入 (800K) Display data input (800K)

包装 (1)

Packaging (1)

编带包装 Fabric with packaging

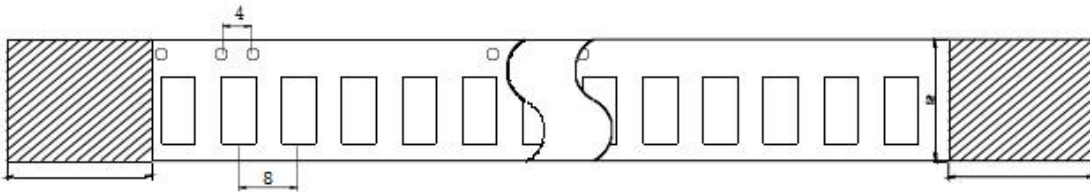

注:

1. 尺寸单位为毫米(mm)。
1. Size unit is mm (mm).
2. 尺寸公差是±0.1mm。
2. The dimensional tolerance is ± 0.1mm.

卷轴尺寸 Scroll size

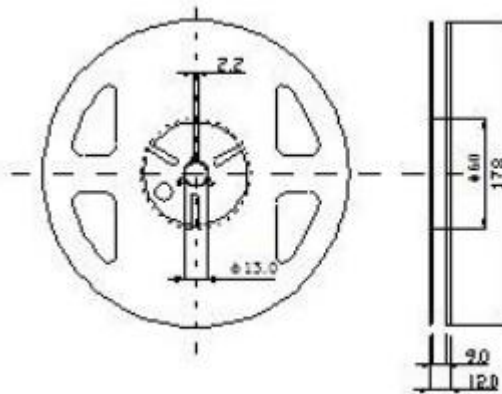

包装 (2)

Packaging (2)

◇ 防潮防静电包装 Moisture Proof and Anti-Electrostatic Foil Bag

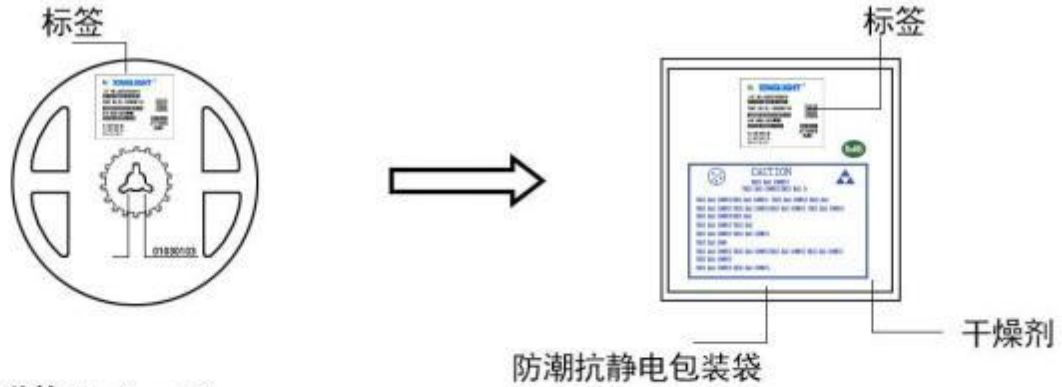

◇ 外包装箱 Cardboard Box

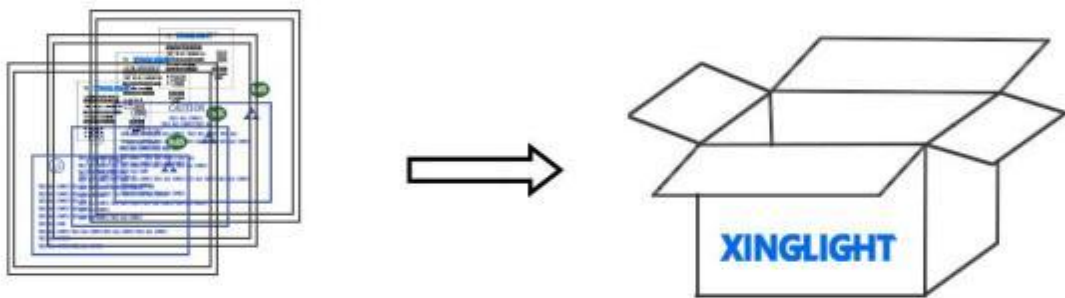

Capacity 5 or 10 reels per box (内箱容量: 50或100卷)

◇ 标签说明: Label Explanation

- LOT NO: 批次信息
- PART NO: 产品型号
- BIN CODE: 产品名称
- WL: 波长范围
- IV: 光强范围
- VF: 电压范围



焊接指导（1）

Guideline for Soldering (1)

回流焊注意事项 Attention to Reflow Welding:

1、无铅锡膏的温度曲线建议，作业前检查回流焊设备的峰值温度/时间是否控制在 $240 \pm 5^\circ\text{C} / \leq 10$ 秒！

The temperature curve of lead-free solder paste is recommended. Before operation, check whether the peak temperature / time of the reflow welding equipment is controlled at $240 \pm 5^\circ\text{C} / \leq 10$ seconds!

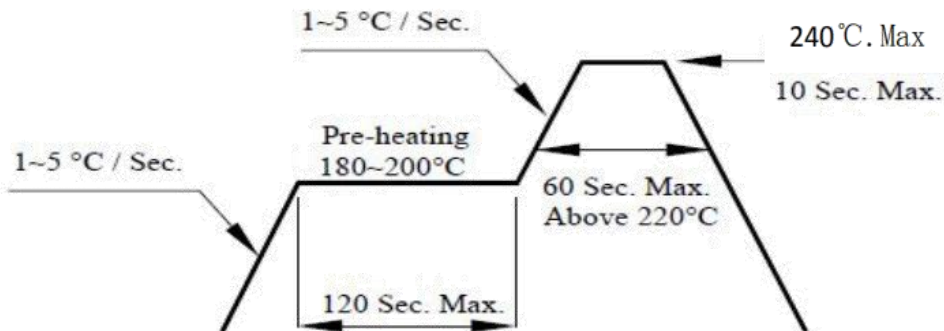

2、建议检查终端产品是否需要经历二次回流焊工艺，二次回流焊工艺具有一定品质风险性，如需请自行评估并尽量缩短二次回流焊间隔时间（建议不超过4小时）；

It is recommended to check whether the terminal product needs to undergo secondary reflow welding process. The secondary reflow welding process has certain quality risks. If you need to evaluate yourself and shorten the secondary reflow welding interval as much as possible (recommended not to exceed 4 hours);

3、焊接期间，加热时不要在 LEDs 上添加任何压力；

Do not add any pressure to the LEDs when heated during welding;

4、焊接后，正常回温至 40°C 以下后才可过电流。

After welding, the normal return temperature is below 40°C before the current can be passed.

焊接指导 (2)

Guideline for Soldering (2)

清洗 Cleaning

在焊接后推荐使用酒精进行清洗，在温度不高于 30°C 的条件下持续 3 分钟，不高于 50°C 的条件下持续 30 秒。使用其他类似溶剂清洗前，请先确认使用的溶剂不会对 LED 的封装和环氧树脂部分造成损伤。

超声波清洗也是有效的方法，一般最大功率不应超过 300W，否则可能对 LED 造成损伤。请根据具体的情况预先测试清洗条件是否会对 LED 造成损伤。

It is recommended that alcohol be used as a solvent for cleaning after soldering. Cleaning is to go under 30°C for 3 minutes or 50°C for 30 seconds. When using other solvents, it should be confirmed beforehand whether the solvents will dissolve the package and the resin or not.

Ultrasonic cleaning is also an effective way for cleaning. But the influence of Ultrasonic cleaning on LED depends on factors such as ultrasonic power. Generally, the ultrasonic power should not be higher than 300W. Before cleaning, a pretest should be done to confirm whether any damage to LEDs will occur.

- * **注意：** 此一般指导原则并不适用于所有 PCB 设计和焊接设备的配置。具体工艺受到诸多因素的影响，请根据特定的PCB设计和焊接设备来确定焊接方案。
- * **Note:** This general guideline may not apply to all PCB designs and configurations of all soldering equipment. The technics in practise is influenced by many factors, it should be specialized base on the PCB designs and configurations of the soldering equipment..

使用注意事项 (1)

Precautions (1)

存储要求: Storage requirements

1. 推荐储存环境: 温度: $5^{\circ}\text{C} - 30^{\circ}\text{C}$; 湿度: 相对湿度 60% 以下;

Recommended storage environment: temperature: $5^{\circ}\text{C} - 30^{\circ}\text{C}$; Humidity: Relative humidity below 60;

2. 防潮袋密封包装储存时间为15天, 起始时间以包装标签日期为准, 包装袋封口良好并无漏气现象, 如超过15天的LED需放进 $65 \pm 5^{\circ}\text{C}$; 相对湿度 $\leq 10\%RH$ 的烤箱烘烤, 烘烤时间: 24小时;

The storage time of the waterproof bag sealed packaging is 15 days. The starting time is based on the date of the packaging label. The packaging bag has a good sealing and no leakage. For example, LEDs over 15 days need to be put into $65 \pm 5^{\circ}\text{C}$; Relative humidity $\leq 10\% RH$ oven baking time: 24 hours;

3、表面贴装器件(SMDs)属于潮湿敏感性元件, 空气中的湿气通过扩散渗透到产品中。当 SMD 元件焊接到电路板上的过程是将其通过温度为 $150^{\circ}\text{C} - 260^{\circ}\text{C}$ 的回流焊, 在高温状态下, 渗入其中的湿气快速膨胀产生足够的蒸汽压力损伤或毁坏 LED 元件, 从而出现材料内胶裂、分层或金线损失等可靠性失效问题;

Surface mount devices(SMDs) are moist sensitive elements, and moisture in the air penetrates the product through diffusion. When the SMD component is welded to the circuit board, it is welded through a return welding at a temperature of $150^{\circ}\text{C} - 260^{\circ}\text{C}$. At a high temperature, the moisture that infiltrates it rapidly expands to produce enough steam pressure damage or damage to the LED component. Therefore, there are reliability failure problems such as internal cracking, delamination or gold wire loss;

4、除潮烘烤条件: 低温除湿, 即去除铝箔袋后将料盘放置在柜式干燥箱内进行 $65 \pm 5^{\circ}\text{C}$ / 相对湿度 $\leq 10\%RH$, 烘烤时间 ≥ 24 小时的除湿作业 (如属热风烤箱则建议除湿时关闭烤箱进风口开关, 关键确保箱内相对湿度 $\leq 10\%RH$)! 且回温过程必须在干燥的环境下进行! 建议产品除湿后在4个小时内完成贴片固焊作业;

Dehumidification baking conditions: low temperature dehumidification, that is, after removing aluminum foil bags, the tray is placed in a cabinet drying box for $65 \pm 5^{\circ}\text{C}$ / relative humidity of $10\% RH$, The baking time is a 12-hour dehumidification(in the case of a hot air oven, it is recommended to close the oven inlet switch when dehumidifying, and the key is to ensure that the relative humidity in the box is $10\% RH$)! And the warming process must be carried out in a dry environment! Recommends that the product be dehumidified and finished within 4 hours;

5、产品拆封后, LED 在温度 $\leq 30^{\circ}\text{C}$, 相对湿度 $\leq 60\%RH$ 的条件下, 请在 12H 内使用完, 若没有使用完的产品需以 $65 \pm 5^{\circ}\text{C} / 24H$ 除潮后密封, 建议放入干燥柜中存放;

After the product is unsealed, the LED is used within 12H under conditions of temperature $\leq 30^{\circ}\text{C}$ and relative humidity $\leq 60\% RH$. If the product is not used, it must be sealed after dehumidification with $65 \pm 5^{\circ}\text{C} / 24H$.
Suggestions for storage in drying cabinets;

使用注意事项 (2)

Precautions (2)

防护措施: Protection measures:

- 1、LED器件封装胶水采用的是硅树脂系原材，终端产品如需户外使用需对器件做二次防护措施并请特别注意：
/The packaging glue for LED devices is made of silicone. If the end product needs to be used outdoors, the device must be protected twice. Please pay special attention to it:
 - A、建议检查各个工艺流程环节应规避产品有堆叠及不规则棱角物伤及产品胶体； /It is recommended that the inspection of various process links should avoid products with stacking and irregular angular injuries and product colloids;
 - B、建议检查各个工艺流程环节应规避产品与硫、卤、酸、醇、碱、酮类强氧化物、塑化剂等腐蚀性物质接触； /It is recommended to avoid contact with corrosive substances such as sulfur, halogen, acid, alcohol, alkali, ketone strong oxide and plasticizer;
 - C、建议检查终端产品是否需要封盖、灌胶、裸板高温挤出、超声等二次封装工艺，如需请评估可能伤及LED器件的风险；是否需要刷胶、涂油、抹漆等二次涂装工艺，如需请评估可能导致器件胶体表面凹凸、污垢等因素影响发光、导热的风险。 /recommends checking whether the terminal product needs to cover, glue, bare plate high temperature extrusion, ultrasound and other secondary packaging process, if necessary, please assess the risk of possible damage to LED devices; If need brush glue, oil, paint and other secondary painting process, if you need to assess the device glue surface bump, dirt and other factors may affect the light emission, heat conductivity risk.

设计建议: Design suggestions:

- 1、电路设计时，建议使用定电流驱动设计，如以定电压设计，请考虑不同电压所造成的影响； /When designing a circuit, it is recommended to use a constant current drive design. If you design with a constant voltage, consider the impact of different voltages;
- 2、LED产品为单向导通性，使用安装前请确认产品极性，一般产品缺口边为产品负极，若反向安装，不能正常点亮，且在施加电压时容易造成LED芯片损伤或失效； /LED products are simple guides, please confirm the polarity of the product before using the installation. The general product gap edge is the negative electrode of the product. If it is installed in the opposite direction, it can not be lit normally, and it is easy to cause LED chip damage or failure when voltage is applied;
- 3、注意正确的电路设计，不当之设计与电流控制，易造成LED失效，如电流过大引起寿命问题甚至烧毁，电流过小引起亮度不足等； /Pay attention to the correct circuit design, improper design and current control, it is easy to cause LED failure, such as excessive current causing life problems or even burning, too small current causing insufficient brightness, etc.;
- 4、不同BIN号之LED建议分开使用，若需安装在同一个组件时，请先确认是否可满足相关电气及光学特性要求，如电流是否均衡，光色、亮度的一致性； /The LEDs of different BIN numbers are recommended to be used separately. If you need to install on the same component, please first confirm whether the relevant electrical and optical characteristics can be met, such as whether the current is balanced, the consistency of light color, brightness, etc
- 5、本规格书列出的产品是设计于普通电子产品的应用，例如电器‘可视化设备、通信产品等等。因此，建议这些产品不应该用于医疗设施、手术设备、航天器、核电控制系统、灾难/犯罪预防设备等类似的设备。这些产品的错误使用可能直接或间接导致威胁到人们的生命或者导致伤害及财产损失。 /The products listed in this specification are designed for applications of ordinary electronic products, such as electrical 'visual equipment, communication products, etc.. Therefore, it is recommended that these products should not be used for similar equipment such as medical facilities, surgical equipment, spacecraft, nuclear power control systems, and disaster-crime prevention equipment. Misuse of these products may directly or indirectly result in a threat to human life or lead to injury and loss of property.

使用注意事项 (3)

Precautions (3)

其他事项: Others

直接用手拿取产品不但会污染封装树脂表面, 也可能由于静电等因素导致产品性能的改变。过度的压力也可能直接影响封装内部的管芯和金线, 因此请勿对产品施加过度压力, 特别当产品处于高温状态下, 例如在回流焊接过程中。

When handling the product, touching the encapsulant with bare hands will not only contaminate its surface, but also affect on its optical characteristics. Excessive force to the encapsulant might result in catastrophic failure of the LEDs due to die breakage or wire deformation. For this reason, please do not put excessive stress on LEDs, especially when the LEDs are heated such as during Reflow Soldering.

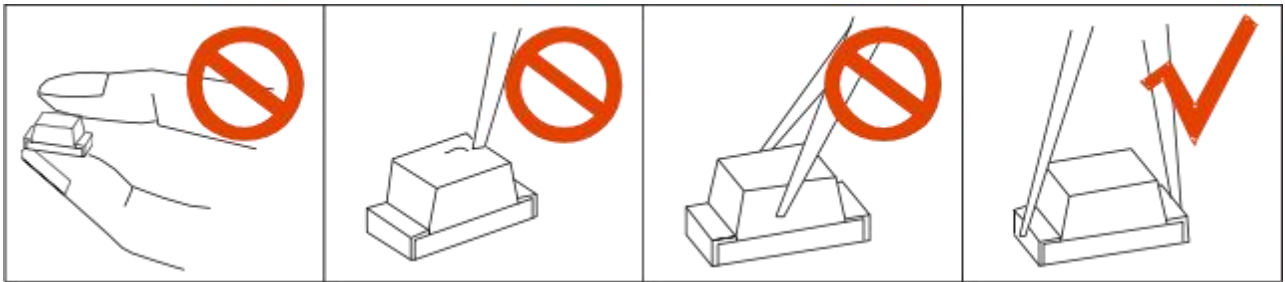

LED 的环氧树脂封装部分相当脆弱, 请勿用坚硬、尖锐的物体刮、擦封装树脂部分。在用镊子夹取的时候也应当小心注意。

The epoxy resin of encapsulant is fragile, so please avoid scratch or friction over the epoxy resin surface. While handling the product with tweezers, do not hold by the epoxy resin, be careful.

眼睛保护忠告: Safety Advice For Human Eyes

LED 发光时, 请勿直视发光光源, 特别是对于一些光强较高的 LED, 强光可能伤害你的眼睛。

Viewing direct to the light emitting center of the LEDs, especially those of great Luminous Intensity, will cause great hazard to human eyes. Please be careful.

X-ON Electronics

Largest Supplier of Electrical and Electronic Components

Click to view similar products for [Standard LEDs - SMD category](#):

Click to view products by [XINGLIGHT manufacturer](#):

Other Similar products are found below :

[LTST-C190KYKT](#) [LTST-C19GD2WT](#) [LTST-N683GBEW](#) [LTW-170ZDC](#) [LTW-M140SZS40](#) [598-8110-100F](#) [598-8170-100F](#) [598-8610-202F](#) [91-21SURC/S530-A3/TR10](#) [AAAF5060QBFSEEZGS](#) [ALMD-LB36-SV002](#) [APT1608QGW](#) [EAST2012YA0](#) [EASV1803BA0](#) [91-21UYC/S530-A3/TR10](#) [SML-512VWT86A](#) [SML-LX0606SISUGC/A](#) [SML-LXL1307SRC-TR](#) [SML-LXR851SIUPGUBC](#) [LT1ED53A](#) [AM27ZGC03](#) [APB3025SGNC](#) [APFA3010SURKCGKQBDC](#) [APHK1608VGCA](#) [APT2012QGW](#) [CLX6D-FKB-CN1R1H1BB7D3D3](#) [LTST-008BGEW](#) [LTST-C250KGKT](#) [LTW-010DCG](#) [LTW-020ZDCG](#) [LTW-21TS5](#) [LTW-220DS5](#) [42-21UYC/S530-A3/TR8](#) [598-8330-117F](#) [SML-LX0402IC-TR](#) [CMDA20AYAA7D1S](#) [CMDA16AYDR7A1X](#) [91-21SYGD/S530-E2/TR7](#) [598-8040-100F](#) [598-8070-100F](#) [598-8140-100F](#) [598-8610-200F](#) [EAST2012GA0](#) [EAPL3527GA5](#) [SML-LXL1209SYC/ATR](#) [EAST2012RA0](#) [EAST1608RGBA0](#) [LTW-008RGB2-PH1](#) [CMD91-21VRC/TR7](#) [SML-LXR851SGSIC-TR](#)