

XL-5050RGBC-SK6812B**技术数据表** Technical Data Sheet**5050幻彩六脚 贴片式发光二极管****特点 (Characteristic) :**

- * 外观尺寸 (L/W/H) :5.0*5.0*1.6mm
Outline Dimensions (L / w / h): 5.0 * 5.0* 1.6 mm
- * 发光颜色及胶体: 高亮度RGB/透明胶体
Luminous color and colloid: high brightness RGB / transparent colloid
- * 环保工艺符合ROHS标准
Environmental protection products Complied With RoHS Directive
- * EIA规范标准包装
EIA standard packaging
- * 适用于SMT贴片自动化生产
Suitable for SMT automatic production
- * 适用于回流焊制程
Suitable for reflow soldering process
- * 断点续传
Breakpoint resume

应用领域 (product application) :

- * LED全彩发光字灯串, LED全彩模组
LED full-color luminous character string, LED full-color module
- * LED全彩软灯条硬灯条
LED full-color soft light strip hard light strip
- * 电器设备跑马灯
Electric equipment marquee
- * 智能音箱, 风扇
Smart speaker, fan
- * 显示屏, 像素屏, 点光源, LED异形屏
Display screen, pixel screen, point light source, LED special-shaped screen
- * 各种电子产品
Various electronic products



目录

Catalogue

| | |
|--|----|
| 电性参数 Electrical Characteristics..... | 5 |
| 典型特性曲线 Typical Characteristic Curves..... | 8 |
| 可靠性实验 Reliability Test Items And Conditions..... | 12 |
| 外形尺寸 Outline Dimensions..... | 13 |
| 包装 Packaging..... | 14 |
| 焊接指导 Guideline for Soldering..... | 16 |
| 使用注意事项 Precautions..... | 18 |

产品概述: Product overview:

XL-5050 (6812) 是一个集控制电路与发光电路于一体的智能外控 LED 光源。其外型 与一个 5050LED 灯珠相同，每个元件即为一个像素点。像素点内部包含了智能数字接口数据锁存信号整形放大驱动电路，电源稳压电路，内置恒流电路，高精度 RC 振荡器，输出驱动采用专利 PWM 技术，有效保证了像素点内光的颜色高一致性。芯片采用单线通讯方式，采用归零码的方式发送信号。芯片在上电复位以后，接受 DIN 端打来的数据，接受够 24 bit 后，DOUT 端口开始转发数据，供下一个芯片提供输入数据。在转发之前，DOUT 口一直拉低。此时芯片将不接受新的数据，芯片 OUTF、OUTG、OUTB 三个 PWM 输出口根据接受到的 24 bit 数据，发出相应的不同占空比的信号，该信号周期在 4 ms。如果 DIN 端输入信号为 RESET 信号，芯片将接收到的数据送显示，芯片将在该信号结束后重新接受新的数据，在接受完开始的 24 bit 数据后，通过 DOUT 口转发数据，芯片在没有接受到 RESET 码前，OUTF、OUTG、OUTB 管脚原输出保持不变，当接受到 80μs 以上低电平 RESET 码后，芯片将刚才接收到的 24 bit PWM 数据脉宽输出到 OUTF、OUTG、OUTB 引脚上。除 DIN 外，芯片额外设计了 FDIN 输入端，接收上一个芯片的 DIN 数据，也就是上上一个芯片的 DOUT 数据。级联时，如果某一颗芯片损坏，不影响数据传输，后续芯片仍能正常接收数据。LED 具有低电压驱动，环保节能，亮度高，散射角度大，一致性好，超低功率，超长寿命等优点。将控制电路集成于 LED 上面，电路变得更加简单，体积小，安装更加简便。

XL-5050 (6812) is an intelligent external control LED light source integrating control circuit and luminous circuit. Its appearance is the same as a 5050 LED lamp bead, and each element is a pixel. The pixel contains an intelligent digital interface data latch signal shaping and amplification drive circuit, a power supply voltage stabilizing circuit, a built-in constant current circuit, a high-precision RC oscillator, and a patented PWM technology for output drive, which effectively ensures the high consistency of the color of the light in the pixel. The chip adopts single line communication mode, and sends signals by returning to zero code. After the chip is powered on and reset, it receives the data from the DIN terminal. After receiving enough 24 bits, the DOUT port starts to forward the data for the next chip to provide input data. The DOUT port is always pulled down before forwarding. At this time, the chip will not accept new data. The chip OUTF, OUTG, and OUTB PWM output ports will send corresponding signals with different duty cycles according to the received 24 bit data. The signal cycle is 4 ms. If the input signal at the DIN end is a RESET signal, the chip will send the received data to the display, and the chip will accept new data after the end of the signal. After receiving the initial 24 bit data, the chip will forward the data through the DOUT port. Before the chip receives the RESET code, the original output of OUTF, OUTG, OUTB pins will remain unchanged. When the chip receives the low-level RESET code above 80 μs, The chip outputs the 24 bit PWM data pulse width just received to OUTF, OUTG and OUTB pins. In addition to DIN, the chip is additionally designed with an FDIN input terminal to receive the DIN data of the previous chip, that is, the DOUT data of the previous chip. When cascading, if a chip is damaged, data transmission will not be affected, and subsequent chips can still receive data normally. LED has the advantages of low voltage drive, environmental protection and energy conservation, high brightness, large scattering angle, good consistency, ultra-low power, and ultra long life. The control circuit is integrated on the LED, which makes the circuit simpler, smaller and easier to install.

产品特征: Product characteristics

- 所有元件集成在 5050 封装中, 不需要任何其他外围元件构成一个完整的外控像素点。
- All components are integrated in the 5050 package, and no other peripheral components are required to form a complete external Controls pixel points.
- 断点续传, 单颗 IC 或灯珠损坏不影响后续整体显示效果。
- Continuous transmission of breakpoints. The damage of a single IC or lamp bead will not affect the subsequent overall display effect.
- 智能反接保护, 12V 电源接反时不会损坏元器件。
- Intelligent reverse connection protection, and components will not be damaged when 12V power supply is connected reversely.
- 内置信号数据整形电路, 接受完本单元数据自动将后续数据整形输出, 保证线路波形畸变不会累加。
- Built in signal data shaping circuit, automatically shaping and outputting the subsequent data after receiving the data of the unit It can be proved that the line waveform distortion will not be accumulated.
- 灰度调节电路 (256 级灰度可调) ●Gray scale adjustment circuit (256 levels of gray scale can be adjusted)
- 完成 16777216 种颜色的全真色彩显示
- Gray scale adjustment circuit (256 levels of gray scale can be adjusted)
- 端口扫描频率 2KHz/s。
- The port scanning frequency is 2KHz/s.
- 串行级联接口, 能通过一根信号线完成数据的接收与解码。
- Serial cascade interface, capable of receiving and decoding data through a signal line.
- 双输入串行级联接口 (DIN. FDIN.)
- Dual input serial cascade interface (DIN. FDIN.)
- 任意两点传输距离在不超过 5 米时无需增加任何电路。
- When the transmission distance between any two points does not exceed 5 meters, no additional circuit is required.
- 当刷新速率 30 帧/秒时, 级联数不小于 1024 点。
- When the refresh rate is 30 frames/second, the number of cascades shall not be less than 1024 points.
- 数据发送速度可达 800Kbps。
- The data transmission speed can reach 800Kbps.
- 输出恒流值 9mA, 便于降低内置灯珠功耗
- The output constant current value is 9mA, which is convenient to reduce the power consumption of the built-in lamp bead
- 内置高精度和高稳定性振荡器
- Built in high precision and high stability oscillator
- 光的颜色高度一致, 性价比高。
- The color of light is highly consistent and cost-effective.
- 采用高压CMOS工艺, 12V单点单控
- High voltage CMOS process, 12V single point single control
- 默认上电不亮灯
- Default power on does not light up

电性参数

Electrical Characteristics

光电参数 (Ta=25℃):

Electro-Optical Characteristics(Ta= 25℃)

| 参数 Parameter | 符号 Symbol | 最小值 Min. | 代表值 Typ. | 最大值 Max. | 单位 Unit |
|-------------------------------------|--------------|-------------|-------------|-------------|------------|
| 输入电压 input voltage | Vin | 10.8 | 12 | 13.2 | V |
| RGB 输出电流 RGB output current | Lol1 | 8.82 | 9 | 9.18 | MA |
| 高电平输入电压 High level input voltage | Vih | 4 | --- | --- | V |
| 低电平输入 Low level input | Vil | --- | --- | 1 | V |
| PWM 频率 PWM frequency | Fpwm | --- | 1.2 | --- | KHZ |
| 静态功耗 Static power consumption | LDD | --- | 2 | --- | MA |

开光说明 (如无特殊说明, TA=25℃,)

| 参数 Parameter | 符号 Symbol | 最小值 Min. | 代表值 Typ. | 最大值 Max. | 单位 Unit | 测试条件 Test conditions |
|-----------------------------------|--------------|-------------|-------------|-------------|------------|-------------------------|
| 数据传输速率 Data transmission rate | FDIN | --- | 800 | --- | kHz | --- |
| 传输延迟时间 Transmission delay time | tPLZ | --- | --- | 500 | ns | --- |

极限参数 (Ta=25℃)

Absolute Maximum Ratings (TA = 25 °C)

| 参数 Parameter | 符号 Symbol | 最大额定值 Maximum rating | 单位 Units |
|---|--------------|-------------------------|-------------|
| 逻辑电源电压 Logic supply voltage | Vin | +5.0~+24.0 | V |
| RGB 输出端口耐压 RGB output port withstand voltage | Vds | 26 | V |
| 逻辑输入电压 Logic input voltage | V1 | -0.5~5.5 | V |
| RGB 输出电流 RGB output current | Lol1 | 12 | MA |
| 工作温度 working temperature | Topt | -40~+80 | °C |
| 储存温度 Storage temperature | Tstg | -50~+150 | °C |
| ESD 耐压 ESD withstand voltage | Vesd | 4K | V |

亮度分档:

Brightness grading

| 颜色 Color | 代码 Code | 最小值 Min. | 最大值 Max. | 单位 Unit | 测试条件 Test conditions |
|-------------|------------|-------------|-------------|------------|-------------------------|
| 红Red | R14 | 500 | 700 | mcd | IF=20mA |
| 绿Green | Z03 | 1300 | 1800 | | |
| 蓝Blue | R13 | 300 | 500 | | |

电压分档:

Voltage grading

| 颜色 Color | 代码 Code | 最小值 Min. | 最大值 Max. | 单位 Unit | 测试条件 Test conditions |
|-------------|------------|-------------|-------------|------------|-------------------------|
| 红Red | A04 | 2.0 | 2.2 | V | IF=20mA |
| 绿Green | A09 | 3.0 | 3.2 | | |
| 蓝Blue | A09 | 3.0 | 3.2 | | |

色温分档:

Color temperature grading

| 颜色 Color | 代码 Code | 最小值 Min. | 最大值 Max. | 单位 Unit | 测试条件 Test conditions |
|-------------|------------|-------------|-------------|------------|-------------------------|
| 红Red | HR02 | 620 | 625 | nm | IF=20mA |
| 绿Green | HG24 | 520 | 525 | | |
| 蓝Blue | HB34 | 465 | 470 | | |

典型特性曲线

Typical Characteristics Curves

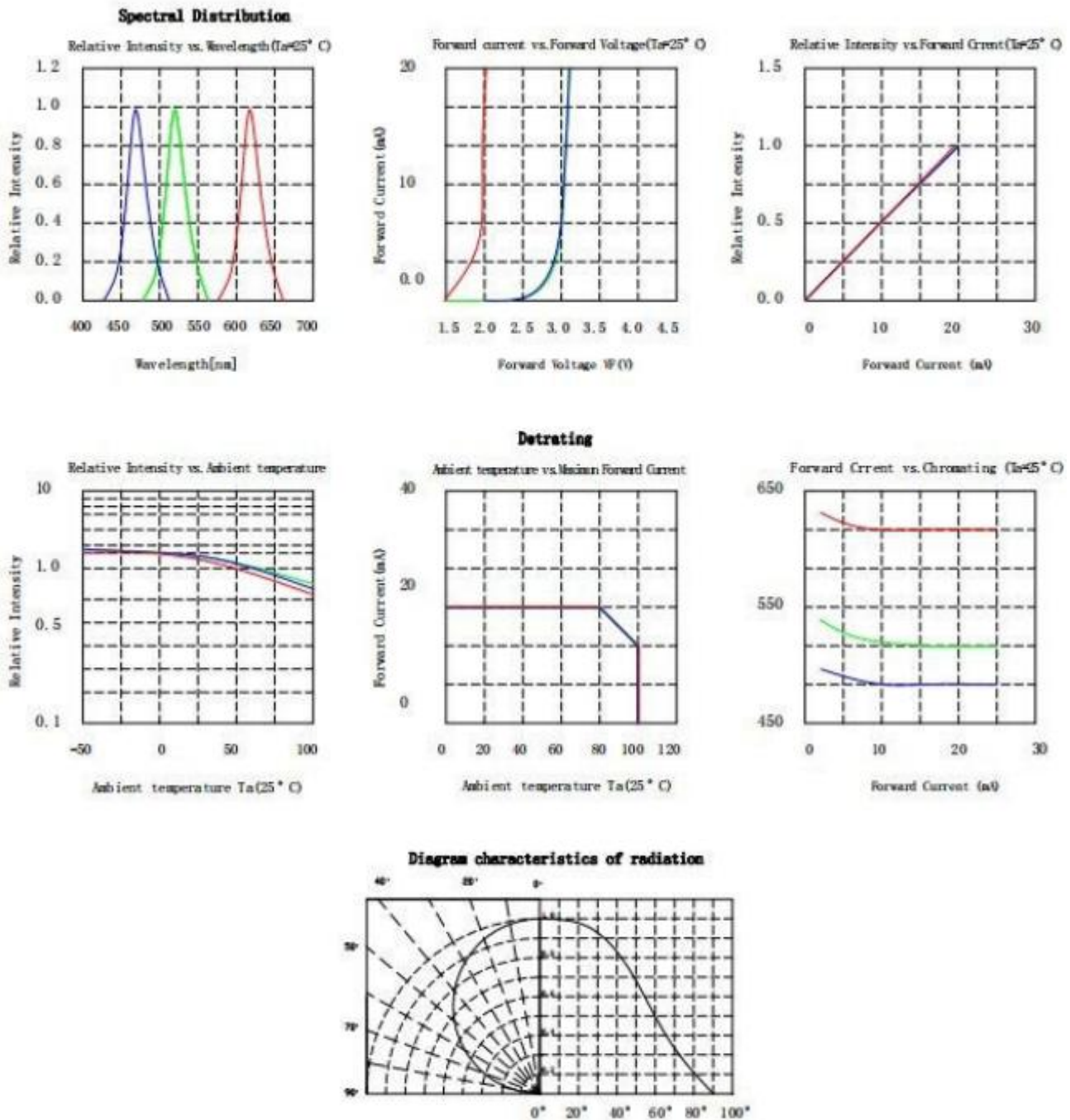

动态参数 (Ta=25℃)

Dynamic parameters (Ta=25 °C)

| 颜色 Color | 符号 Symbol | 典型值 Typical value | 单位 Unit | 测试条件 Test conditions |
|--------------------------------------|----------------|----------------------|------------|-------------------------|
| 数据传输速度 Data transmission speed | fDIN | 800 | KHZ | 5.2 |
| DOUT 传输延迟 DOUT transmission delay | TDLY | 500 | ns | 5.2 |
| R/G/B输出电流 | Iron/Igon/Ibon | 13.2 | mA | Vr/Vg/Vb=3v |

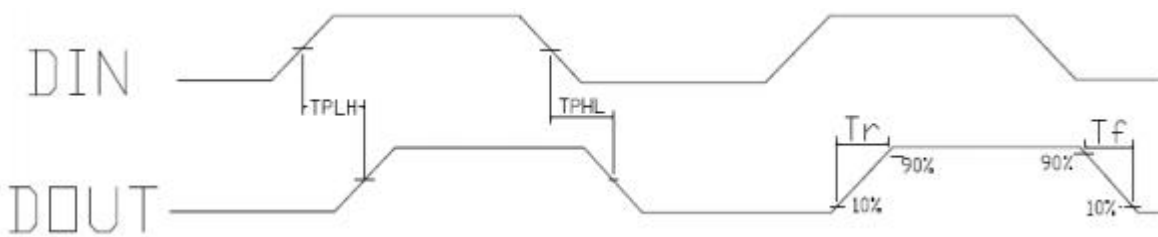

时序波形图 :Time sequence oscillogram

1. 输入码型:

Input code type:

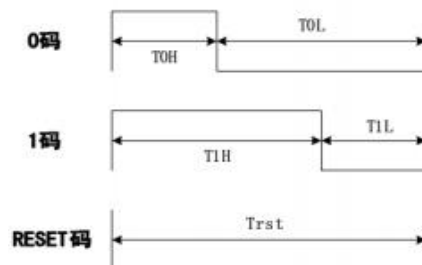

2. 码型时间: Code type time

| 时序表名称 Timeline name | 最小值 Min. | 典型值 Typical value | 最大值 Max. | 单位 Unit |
|------------------------|-------------|----------------------|-------------|------------|
| T | 0.89 | --- | --- | μs |
| TOH | --- | 0.3 | --- | μs |
| TOL | --- | 0.9 | --- | μs |
| T1H | --- | 0.9 | --- | μs |
| T1L | --- | 0.3 | --- | μs |
| TRST | 80 | --- | --- | μs |

注 1: 写程序时, 码元周期最低要求为 0.9us;

Note 1: When writing the program, the minimum code cycle is 0.9us;

2: 0 码、1 码的高电平时间需按照上表的规定范围, 0 码、1 码的低电平时间要求小于 15us;

2: The high level time of code 0 and code 1 shall be within the range specified in the table above, and the low level time of code 0 and code 1 shall be less than 15us;

3. 协议数据格式: Protocol Data Format

Trst+第一颗芯片 24bits 数据+第二颗芯片 24bits 数据+.....+第 N 颗芯片 24bits 数据

+Trst 24bit 灰度数据结构: 高位



数据传输方法

Data transmission method

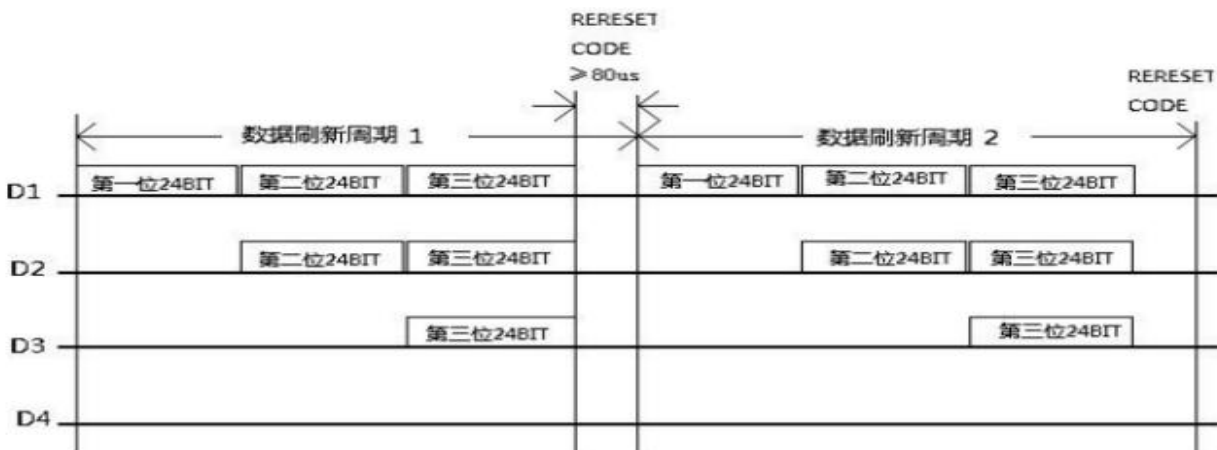

注: 其中 D1 为 MCU 端发送的数据, D2、D3、D4 为级联电路自动整形转发的数据。

Note: D1 is the data sent by MCU, D2, D3 and D4 are the data automatically shaped and forwarded by cascade circuit.

连接方式：
Connection mode:

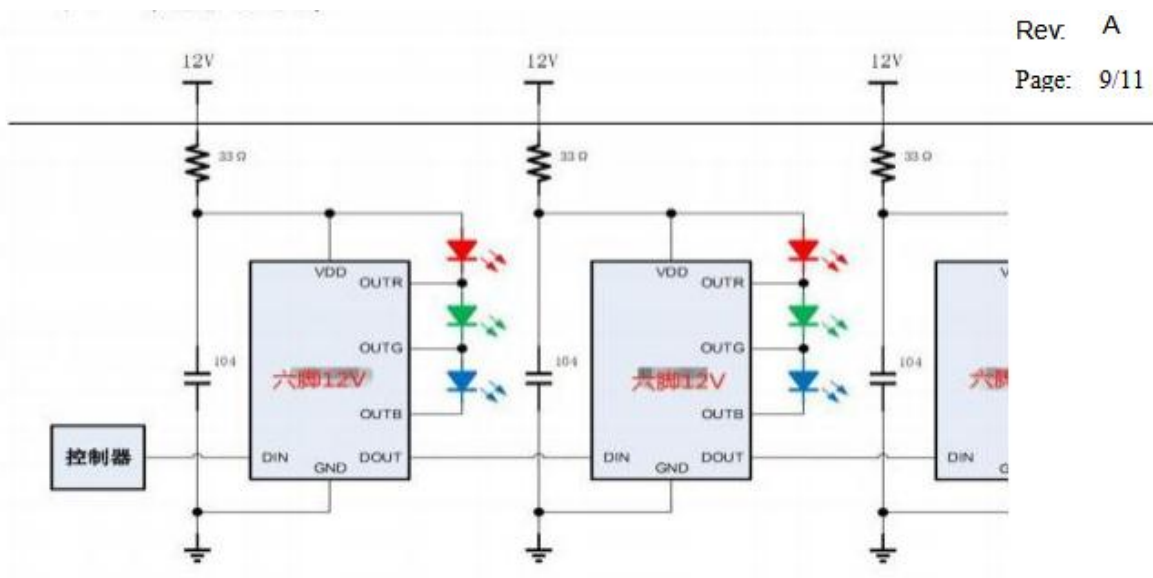
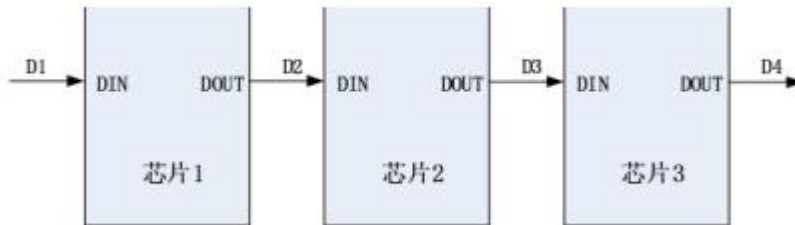

Rev: A

Page: 9/11

电容常规接 104 贴片电容

注：红色为线路跟焊盘 电容起滤波作用，贴片根据灯珠缺口位置贴。
如果线路需要更改根据脚位调整。

Connection mode: capacitor connected to 104 chip capacitor

Note: The red color indicates that the circuit and the pad capacitor play a filtering role, and the patch is pasted according to the position of the lamp bead gap.

If the line needs to be changed, adjust according to the foot position.

可靠性试验

Reliability Test Items And Conditions

| 类型 Type | 测试项目 Test items | 参考标准 Reference standard | 测试条件 Test conditions | 注释 notes | 失效 LED 数量 (PCS) Number of failed LEDs Quantity (PCS) |
|-----------------------------|--|----------------------------|---|-----------------------|--|
| 环境顺序 Environmental order | 回流焊耐热测试 Reflow soldering heat resistance test | JESD22-B106 | Tsld(回流焊温度)=260℃, 10sec | 2次 2 times | 0/22 |
| | 温度循环 Temperature cycle | JESD22-A104 | -40℃ 30min ↑↓ 5min 100℃ 30min | 100周期 100 cycles | 0/22 |
| | 冷热冲击 Thermal Shock | JESD22-A106 | -40℃ 15min ↑↓ 5min 100℃ 15min | 100周期 100 cycles | 0/22 |
| | 高温储存 High temperature storage | JESD22-A103 | Ta=100℃ | 1000小时 1000 hours | 0/22 |
| | 低温储存 Low temperature storage | JESD22-A119 | Ta=-40℃ | 1000小时 1000 hours | 0/22 |
| | 间断点亮测试 Intermittent lighting test | JESD22-A105 | On 5min -40℃ > 15min ↑↓<15min Off 5min 100℃ > 15min | 1000周期 1000 cycles | 0/22 |
| 操作顺序 Operation sequence | 老化寿命测试 Aging life test | JESD22-A108 | Ta=25℃ IF=5V | 1000小时 1000 hours | 0/22 |
| | 高温高湿老化测试 High temperature and humidity aging test | JESD22-A101 | 60℃RH=90% IF=5V | 1000小时 1000 hours | 0/22 |

失效标准 Test criteria

| 项目 project | 符号 Symbol | 测试条件 Test conditions | 失效标准 Failure criteria | |
|---------------------------------------|--------------|---|--|------------|
| | | | 最小 minimum | 最大 maximum |
| 发光强度 Luminous intensity | IV | DC=5V, 规格典型 电流 DC=5V, typical specification electric current | 初始数据 X0.7 Initial data X0.7 | --- |
| 耐焊接热 Resistance to welding heat | --- | DC=5V, 规格典型 电流 DC=5V, typical specification electric current | 无死灯或 明显损坏 No dead light or Obvious damage | --- |

外形尺寸

Outline Dimension

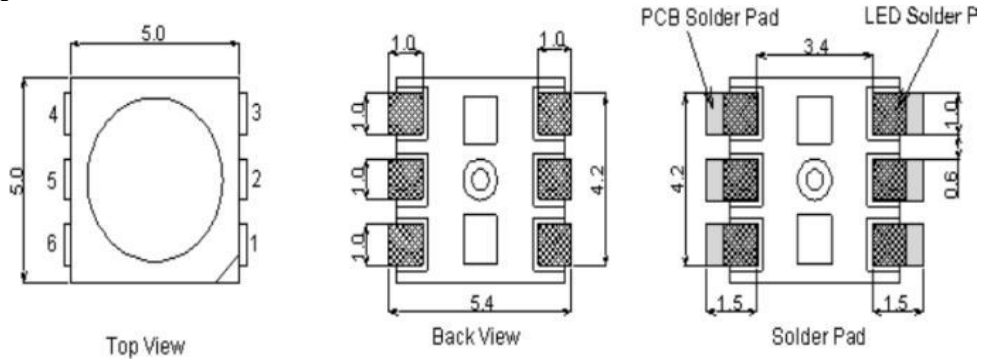

LED引脚示意图:

LED pin diagram:

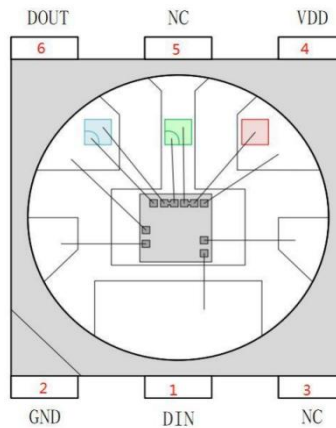

备注: 1. 以上尺寸单位均为mm

Remarks: All dimensions are in millimeters.

2. 未特别标注公差尺寸公差均为±0.25mm

Tolerance is ±0.25mm unless otherwise noted

LED引脚功能:

LED pin function:

| 引脚序号 Pin No | 符号 Symbol | 管脚名 Pin name | 功能描述 Function description |
|----------------|--------------|------------------|---|
| 1 | DIN | 数据输入 data input | 控制数据信号输入脚/辅助信号输出 Control data signal input pin/auxiliary signal output |
| 2 | GND | 地线 Ground wire | 接地 Grounding |
| 3 | NC | 空脚 Empty foot | PCB LAYOUT 时悬空处理, 连接到其他线路会引电路工作异常 When PCB is suspended, it will lead to abnormal circuit operation when connected to other lines |
| 4 | VDD | 电源 Power Supply | LED芯片电源 LED chip power |
| 5 | NC | 空脚 Empty foot | PCB LAYOUT 时悬空处理, 连接到其他线路会引电路工作异常 When PCB is suspended, it will lead to abnormal circuit operation when connected to other lines |
| 6 | DO | 数据输出 data output | 控制数据信号输入脚 Control data signal input pin |

包装 (1)

Packaging (1)

载带 Carrier Tape

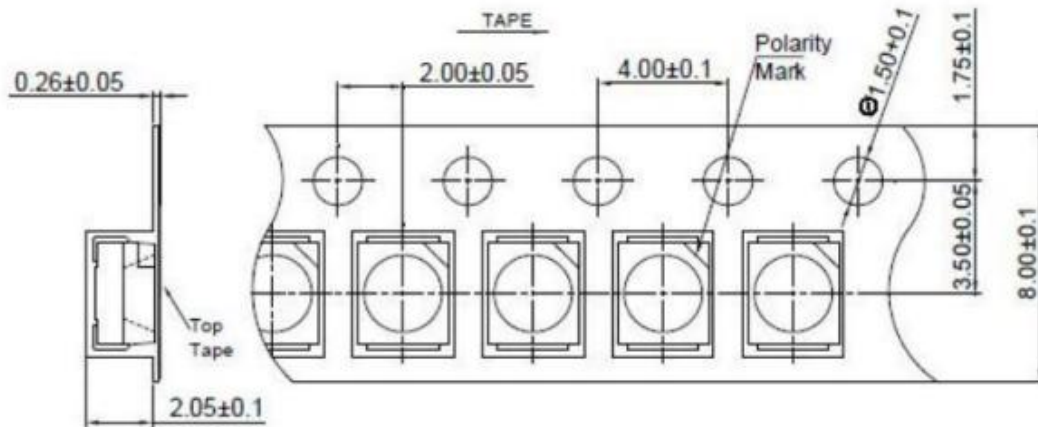

单位: mm, 未注公差: ± 0.1 mm

All dimensions in mm, tolerances unless mentioned is ± 0.1 mm.

◇ 带盘 Reel Dimension

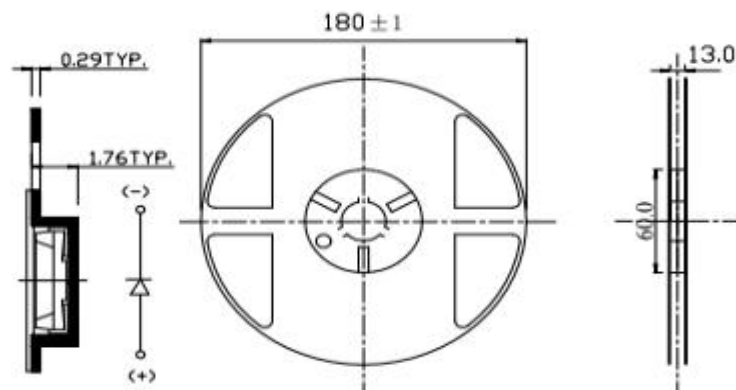

包装 (2)

Packaging (2)

◇ 防潮防静电包装 Moisture Proof and Anti-Electrostatic Foil Bag

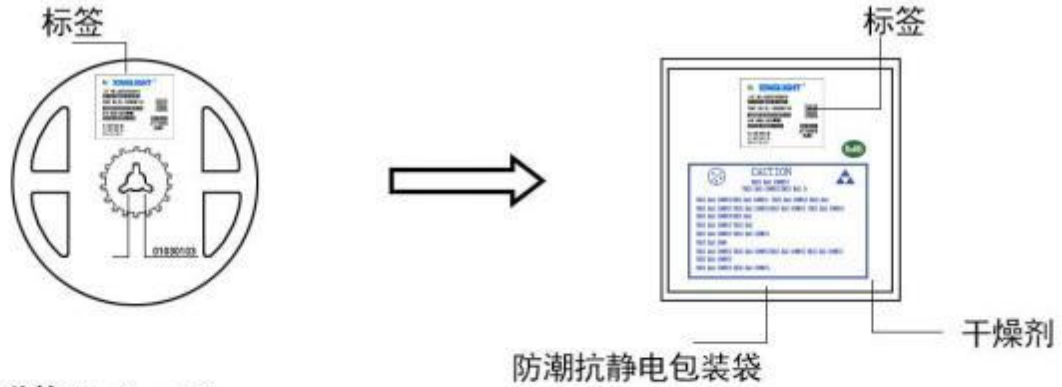

◇ 外包装箱 Cardboard Box

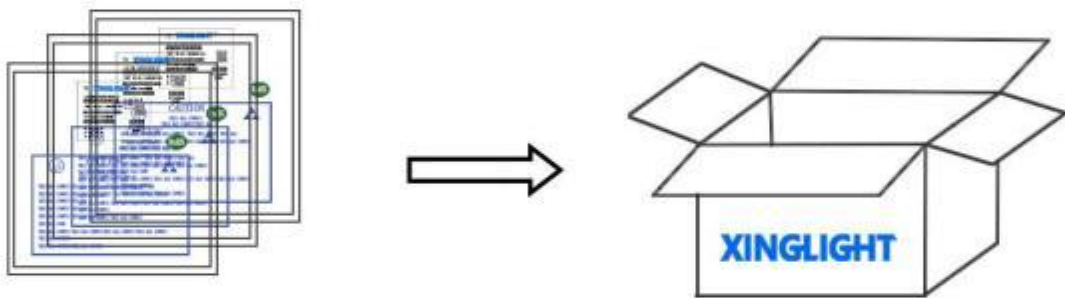

Capacity 5 or 10 reels per box (内箱容量: 50或100卷)

◇ 标签说明: Label Explanation

- LOT NO: 批次信息
- PART NO: 产品型号
- BIN CODE: 产品名称
- WL: 波长范围
- IV: 光强范围
- VF: 电压范围



焊接指导（1）

Guideline for Soldering (1)

1. 使用烙铁人手焊接

Hand Soldering

推荐使用功率低于 20W 的烙铁，焊接时烙铁的温度必须保持在 300℃ 以下，且每个电极只能进行一次焊接，每次焊接的持续时间不得超过 3 秒。

人手焊接过程中的不慎操作易引起 LED 产品的损坏，应当小心谨慎。

A soldering iron of less than 20W is recommended to be used in Hand Soldering. Please keep the temperature of the soldering iron under 300℃ while soldering. Each terminal of the LED is to go for less than 3 second and for one time only.

Be careful because the damage of the product is often started at the time of the hand soldering.

2. 回流焊接： 推荐使用以下无铅回流焊接温度图进行。

Reflow Soldering: Use the conditions shown in the under Figure of Pb-Free Reflow Soldering.

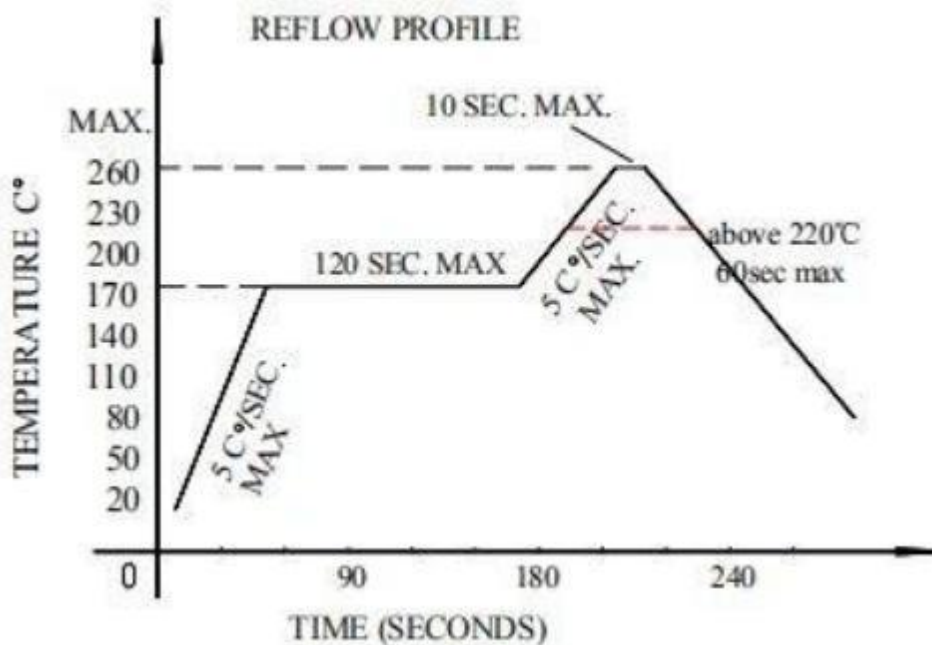

- 回流焊接最多只能进行两次。

Reflow soldering should not be done more than two times.

- 在回流焊接升温过程中，请不要对 LED 施加任何压力。

Stress on the LEDs should be avoided during heating in soldering process.

- 在焊接完成后，待产品温度下降到室温之后，再进行其他处理。

After soldering, do not deal with the product before its temperature drop down to room temperature.

焊接指导 (2)

Guideline for Soldering (2)

3. 清洗:

Cleaning

在焊接后推荐使用酒精进行清洗，在温度不高于 30°C 的条件下持续 3 分钟，不高于 50°C 的条件下持续 30 秒。使用其他类似溶剂清洗前，请先确认使用的溶剂不会对 LED 的封装和环氧树脂部分造成损伤。

超声波清洗也是有效的方法，一般最大功率不应超过 300W，否则可能对 LED 造成损伤。请根据具体的情况预先测试清洗条件是否会对 LED 造成损伤。

It is recommended that alcohol be used as a solvent for cleaning after soldering. Cleaning is to go under 30°C for 3 minutes or 50°C for 30 seconds. When using other solvents, it should be confirmed beforehand whether the solvents will dissolve the package and the resin or not.

Ultrasonic cleaning is also an effective way for cleaning. But the influence of Ultrasonic cleaning on LED depends on factors such as ultrasonic power. Generally, the ultrasonic power should not be higher than 300W. Before cleaning, a pretest should be done to confirm whether any damage to LEDs will occur.

4. 焊锡丝及锡膏的选择:

Selection of solder wire and solder paste:

不用含硫化物或溴化物的焊锡丝及锡膏，因为硫化物或溴化物会与支架表面电镀的银层进行化学反应，导致银层变黑，led 灯珠衰减就变大。

Selection of solder wire and solder paste: do not use solder wire and solder paste containing sulfide or bromide, because sulfide or bromide will chemically react with the silver layer plated on the surface of the support, causing the silver layer to become black, and the attenuation of led lamp beads will become larger.

*** 注意:** 此一般指导原则并不适用于所有 PCB 设计和焊接设备的配置。具体工艺受到诸多因素的影响，请根据特定的 PCB 设计和焊接设备来确定焊接方案。

*** Note:** This general guideline may not apply to all PCB designs and configurations of all soldering equipment. The technics in practise is influenced by many factors, it should be specialized base on the PCB designs and configurations of the soldering equipment..

使用注意事项（1）

Precautions (1)

1. 贮存：

Storage

- 本产品使用密封防潮抗静电袋包装，并附有干燥剂，未开封的产品有一年的保存时间。

Moisture proof and anti-electrostatic package with moisture absorbent material is used, to keep moisture to a minimum.

- 开封前，产品须存放在温度不高于 30℃，湿度不高于 60%RH 的环境中。

Before opening the package, the product should be kept at 30℃ or less and humidity less than 60% RH, and be used within a year.

- 开封后，产品须存放在温度不高于 30℃，湿度不高于 10%RH 的环境中，且应该在 168 小时（7 天）内使用完。建议工作环境为温度不高于 30℃，湿度不高于 60%RH。

After opening the package, the product should be stored at 30℃ or less and humidity less than 10%RH, and be soldered within 168 hours (7 days). It is recommended that the product be operated at the workshop condition of 30℃ or less and humidity less than 60%RH.

- 对于尚未焊接的 LED，如果吸湿剂或包装失效，或者产品没有符合以上有效存储条件，烘焙可以起到一定的性能恢复效果。烘焙条件：(60±5)℃，持续 24 小时。

If the moisture absorbent material has fade away or the LEDs have exceeded the storage time, baking treatment should be performed based on the following condition: (60±5)℃ for 24 hours.

2. 静电：

Static Electricity

静电和电涌会导致产品特性发生改变，例如正向电压降低等，如果情况严重甚至会损毁产品。所以在使用时必须采取有效的防静电措施。

所有相关的设备和机器都应该正确接地，同时必须采取其他防止静电和电涌的措施。

使用防静电手环，防静电垫子，防静电工作服、工作鞋、手套，防静电容器，都是有效的防止静电和电涌的措施。

Static electricity or surge voltage damages the LEDs. Damaged LEDs will show some unusual characteristic such as the forward voltage becomes lower, or the LEDs do not light at the low current. even not light.

All devices, equipment and machinery must be properly grounded. At the same time, it is recommended that wrist bands or anti-electrostatic gloves, anti-electrostatic containers be used when dealing with the LEDs.

使用注意事项 (2)

Precautions (2)

3. 设计建议:

Design Consideration

设计电路时，通过 LED 的电流不能超过规定的最大值，同时，还需使用保护电阻，否则，微小的电压变化将会引起较大的电流变化，可能导致产品损毁。

建议使用以下 (A) 电路，该电路能够很好的调节通过每个 LED 的电流；不推荐使用 (B) 电路，该电路在持续的电压驱动下，LED 的正向电压 (V_F) 发生变化，电流会随之而发生变化，可能使某些 LED 承受高于规定的电流值。

In designing a circuit, the current through each LED must not exceed the absolute maximum rating specified for each LED. In the meanwhile, resistors for protection should be applied, otherwise slight voltage shift will cause big current change, burn out may happen.

It is recommended to use Circuit A which regulates the current flowing through each LED rather than Circuit B. When driving LEDs with a constant voltage in Circuit B, the current through the LEDs may vary due to the variation in Forward Voltage (V_F) of the LEDs. In the worst case, some LED may be subjected to stresses in excess of the Absolute Maximum Rating.

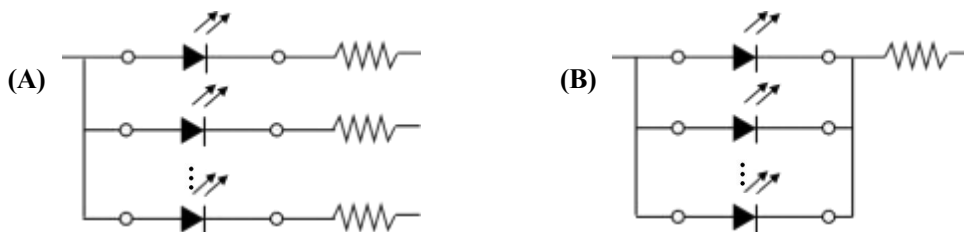

LED 的特性容易因为自身的发热和环境的温度的改变而发生改变。温度的升高会降低 LED 的发光效率、影响发光颜色等，所以在设计时应充分考虑散热的问题。

Thermal Design is paramount importance because heat generation may result in the Characteristics decline, such as brightness decreased, Color changed and so on. Please consider the heat generation of the LEDs when making the system design.

使用注意事项 (3)

Precautions (3)

4. 其他事项:

Others

直接用手拿取产品不但会污染封装树脂表面，也可能由于静电等因素导致产品性能的改变。过度的压力也可能直接影响封装内部的管芯和金线，因此请勿对产品施加过度压力，特别当产品处于高温状态下，例如在回流焊接过程中。

When handling the product, touching the encapsulant with bare hands will not only contaminate its surface, but also affect on its optical characteristics. Excessive force to the encapsulant might result in catastrophic failure of the LEDs due to die breakage or wire deformation. For this reason, please do not put excessive stress on LEDs, especially when the LEDs are heated such as during Reflow Soldering.

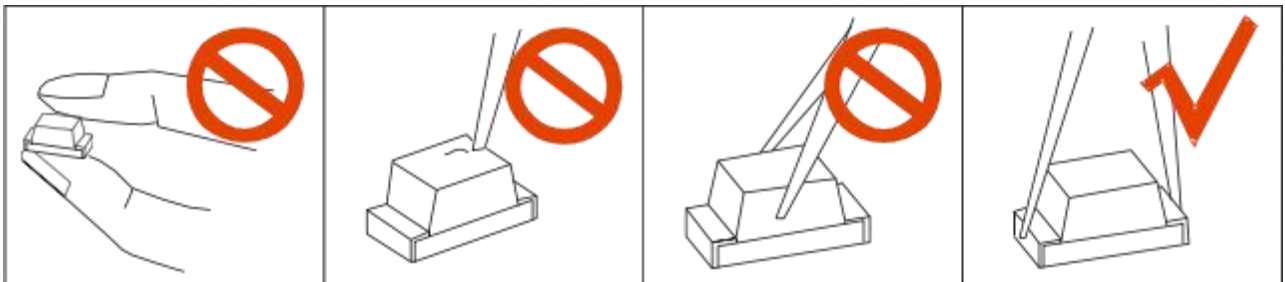

LED 的环氧树脂封装部分相当脆弱，请勿用坚硬、尖锐的物体刮、擦封装树脂部分。在用镊子夹取的时候也应当小心注意。

The epoxy resin of encapsulant is fragile, so please avoid scratch or friction over the epoxy resin surface. While handling the product with tweezers, do not hold by the epoxy resin, be careful.

5. 眼睛保护忠告:

Safety Advice For Human Eyes

LED 发光时，请勿直视发光光源，特别是对于一些光强较高的 LED，强光可能伤害你的眼睛。

Viewing direct to the light emitting center of the LEDs, especially those of great Luminous Intensity, will cause great hazard to human eyes. Please be careful.

X-ON Electronics

Largest Supplier of Electrical and Electronic Components

Click to view similar products for [Standard LEDs - SMD category](#):

Click to view products by [XINGLIGHT manufacturer](#):

Other Similar products are found below :

[LTST-C190KYKT](#) [LTST-C19GD2WT](#) [LTST-N683GBEW](#) [LTW-170ZDC](#) [LTW-M140SZS40](#) [LTW-M140ZVS](#) [598-8110-100F](#) [598-8170-100F](#) [598-8610-202F](#) [AAAF5060QBFSEEZGS](#) [ALMD-LB36-SV002](#) [APT1608QGWW](#) [EAST2012YA0](#) [EASV1803BA0](#) [SML-512VWT86A](#) [SML-LX0606SISUGC/A](#) [SML-LXL1307SRC-TR](#) [SML-LXR851SIUPGUBC](#) [LT1ED53A](#) [AM27ZGC03](#) [APB3025SGNC](#) [APFA3010SURKCGKQBDC](#) [APHK1608VGCA](#) [APT2012QGWW](#) [CLX6D-FKB-CN1R1H1BB7D3D3](#) [LTST-008BGEW](#) [LTW-020ZDCG](#) [LTW-21TS5](#) [LTW-220DS5](#) [598-8330-117F](#) [SML-LX0402IC-TR](#) [CMDA20AYAA7D1S](#) [CMDA16AYDR7A1X](#) [91-21SYGD/S530-E2/TR7](#) [598-8040-100F](#) [598-8070-100F](#) [598-8140-100F](#) [598-8610-200F](#) [EAST2012GA0](#) [EAPL3527GA5](#) [EAST2012RA0](#) [CMD91-21VRC/TR7](#) [SML-LXR851SGSIC-TR](#) [SML-512PWT86A](#) [SMF-2432GYC-TR](#) [LTST-C194TBKT-5A](#) [CLX6E-FKC-CH1M1D1BB7C3D3](#) [SML-LXL0805USBC-TR](#) [SML-LX2835SYSUGCTR](#) [CLMUC-FKA-CL81C1L51BB7C3C3](#)