

DATA SHEET

XA17-G4K: 20 MHz to 4.0 GHz GaAs SPDT Switch

Applications

- General purpose medium-power switches in telecommunication applications
- Transmit/receive switches in 802.11 b/g WLAN Bluetooth[®] systems

Features

- IP1dB = +30 dBm typical @ 3 V
- IP3 = +43 dBm typical @ 3 V
- Low insertion loss, 0.3 dB @ 0.9 GHz
- Low DC power consumption
- Ultra-miniature, SC-70 (6-pin, 2.00 x 1.25 mm) package (MSL1, 260 °C per JEDEC J-STD-020)

Description

The XA17-G4K is a pHEMT GaAs FET single-pole, double-throw (SPDT) switch. The device features low insertion loss and positive voltage operation with very low DC power consumption. The XA17-G4K is manufactured in a compact, low-cost 2.00 x 1.25 mm, 6-pin SC-70 package.

A functional block diagram is shown in Figure 1. The pin configuration and package are shown in Figure 2. Signal pin assignments and functional pin descriptions are provided in Table 1.

 Skyworks Green[™] products are compliant with all applicable legislation and are halogen-free. For additional information, refer to *Skyworks Definition of Green[™]*, document number SQ04-0074.

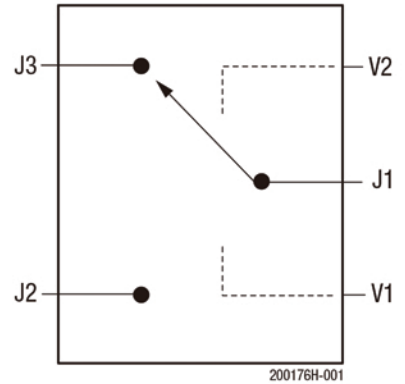

Figure 2. XA17-G4K Block Diagram

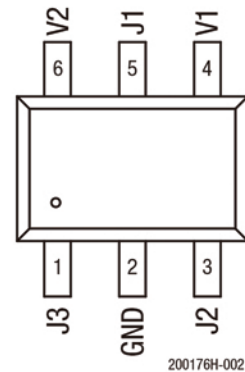

Figure 2. XA17-G4K Pinout (Top View)

Table 1. XA17-G4K Signal Descriptions¹

Pin	Name	Description	Pin	Name	Description
1	J3	RF output (Note 1)	4	V1	DC control voltage
2	GND	Ground	5	J1	RF output (Note 1)
3	J2	RF output (Note 1)	6	V2	DC control voltage

¹ A 100 pF blocking capacitor is required for >500 MHz operation. Use larger value capacitors for lower frequency operation.

Electrical and Mechanical Specifications

The absolute maximum ratings of the XA17-G4K are provided in Table 2. Electrical specifications are provided in Table 3. Typical performance characteristics are shown in Figures 3, 4, and 5.

Table 2. XA17-G4K Absolute Maximum Ratings¹

Parameter	Symbol	Minimum	Maximum	Units
Control voltage	V _{CTL}	-1.2	+8.0	V
RF input power (V _{CTL} = 0 to 7 V): >500 MHz <500 MHz			6 500	W mW
Operating temperature	T _{OP}	-40	+85	°C
Operating temperature (Pinmax < +32 dBm for T _{OP} = 105 °C)	T _{OP}	-40	+105	°C
Storage temperature	T _{STG}	-65	+150	°C

¹ Exposure to maximum rating conditions for extended periods may reduce device reliability. There is no damage to device with only one parameter set at the limit and all other parameters set at or below their nominal value.

CAUTION: Although this device is designed to be as robust as possible, electrostatic discharge (ESD) can damage this device. This device must be protected at all times from ESD. Static charges may easily produce potentials of several kilovolts on the human body or equipment, which can discharge without detection. Industry-standard ESD precautions should be used at all times.

Table 3. XA17-G4K Electrical Specifications¹ (1 of 2)

(V_{CTL} = 0 to 3 V, T_{OP} = +25 °C, Characteristic Impedance = 50 Ω, Unless Otherwise Noted)

Parameter	Symbol	Test Condition	Min	Typical	Max	Units
Insertion loss ^{2,3}	IL	0.02 to 1.0 GHz		0.3	0.4	dB
		1.0 to 2.0 GHz		0.4	0.5	dB
		2.0 to 3.0 GHz		0.4	0.6	dB
		3.0 to 4.0 GHz		0.5	0.7	dB
Isolation ³	ISO	0.02 to 1.0 GHz	22	25		dB
		1.0 to 2.0 GHz	22	25		dB
		2.0 to 3.0 GHz	20	23		dB
Return loss ^{3,4}	RL	0.02 to 1.0 GHz	15		20	dB
		1.0 to 2.0 GHz	15		20	dB
		2.0 to 3.0 GHz	14		17	dB
		3.0 to 4.0 GHz	13		15	dB
Switching characteristics: Rise/fall On/off Video feedthrough		10/90% or 90/10% RF		10		ns
		50% control to 90/10% RF		100		ns
		t _r = 1 ns, bandwidth = 500 MHz		25		mV

Table 3. XA17-G4K Electrical Specifications¹ (2 of 2)**(V_{CTL} = 0 to 3 V, T_{OP} = +25 °C, Characteristic Impedance = 50 Ω, Unless Otherwise Noted)**

Parameter	Symbol	Test Condition	Min	Typical	Max	Units
1 dB input compression point	IP1dB	@ 0.5 to 3.0 GHz V _{CTL} = 0 to 2 V V _{CTL} = 0 to 3 V V _{CTL} = 0 to 5 V		+26 +30 +34		dBm dBm dBm
		@ 48 MHz V _{CTL} = 0 to 3 V V _{CTL} = 0 to 5 V		+28.9 +29.5		dBm dBm
		@ 3.0 to 4.0 GHz V _{CTL} = 0 to 3 V V _{CTL} = 0 to 5 V		+29 +32		dBm dBm
Third order intercept point	IP3	+5 dBm two-tone input power @ 0.5 to 3.0 GHz V _{CTL} = 0 to 2 V V _{CTL} = 0 to 3 V V _{CTL} = 0 to 5 V		+43 +43 +50		dBm dBm dBm
		+5 dBm two-tone input power @3.0 to 4.0 GHz V _{CTL} = 5 V		+45		dBm
Thermal resistance				25		°C/W
Control voltage: Low (@ 20 μA max) High (@100 μA max) High (@ 200 μA max)	V _{CTL_L}		0		0.2	V
	V _{CTL_H}				2.0	V
	V _{CTL_H}				5.0	V

¹ Performance is guaranteed only under the conditions listed in this table.² Insertion loss changes by 0.003 dB/°C.³ Typical performance maintained with V_{CTL} = 0.2 V.⁴ Insertion loss state.

Typical Performance Characteristics

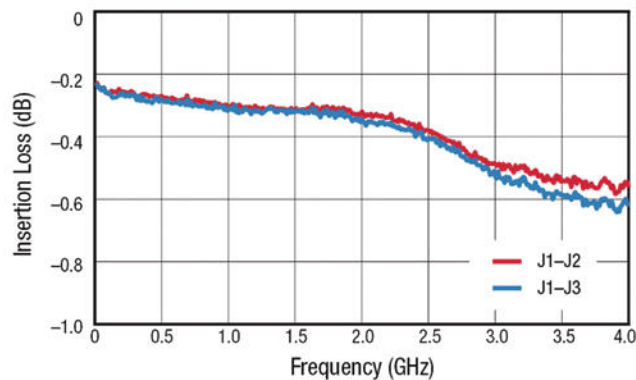
(V_{CTL} = 0 to 3 V, T_{OP} = +25 °C, P_{IN} = 0 dBm, Characteristic Impedance [Z₀] = 50 Ω, C_{BL} = 100 pF, Unless Otherwise Noted)**Figure 3. Insertion Loss vs Frequency**

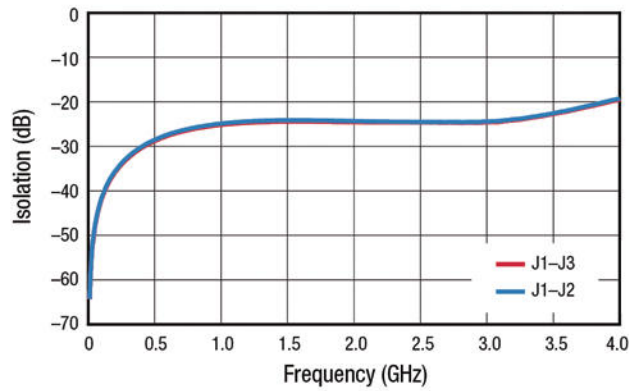

Figure 4. Isolation vs Frequency

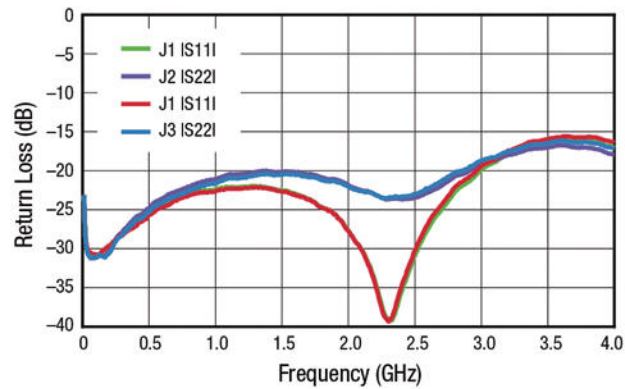

Figure 5. Return Loss vs Frequency

Table 4. Truth Table ($V_{HIGH} = 2$ to 5 V)¹

V1	V2	J1-J2	J1-J3
V_{HIGH}	0	Isolation	Insertion loss
0	V_{HIGH}	Insertion loss	Isolation

¹ Any state other than described in this table places the device in an undefined state. An undefined state does not damage the device.

Evaluation Board Description

The XA17-G4K Evaluation Board is used to test the performance of the XA17-G4K SPDT switch. An Evaluation Board schematic diagram is provided in Figure 6. An assembly drawing for the Evaluation Board is shown in Figure 7.

Package Dimensions

Package dimensions are shown in Figure 8, and tape and reel dimensions are provided in Figure 9.

Package and Handling Information

Instructions on the shipping container label regarding exposure to moisture after the container seal is broken must be followed. Otherwise, problems related to moisture absorption may occur when the part is subjected to high temperature during solder assembly.

The XA17-G4K is rated to Moisture Sensitivity Level 1 at 260 °C. It can be used for lead or lead-free soldering.

Care must be taken when attaching this product, whether it is done manually or in a production solder reflow environment. Production quantities of this product are shipped in a standard tape and reel format.

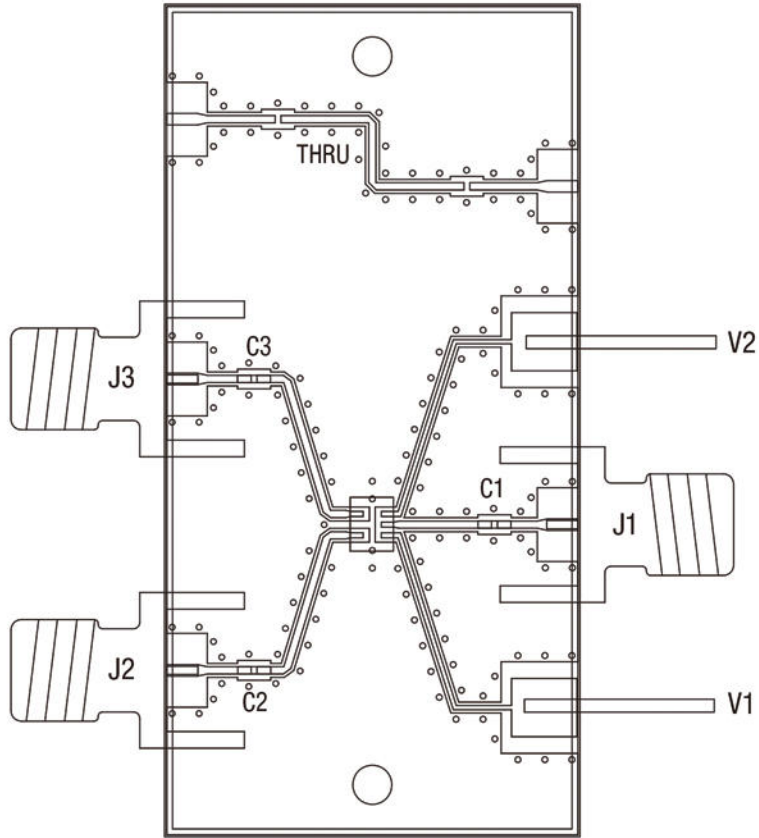
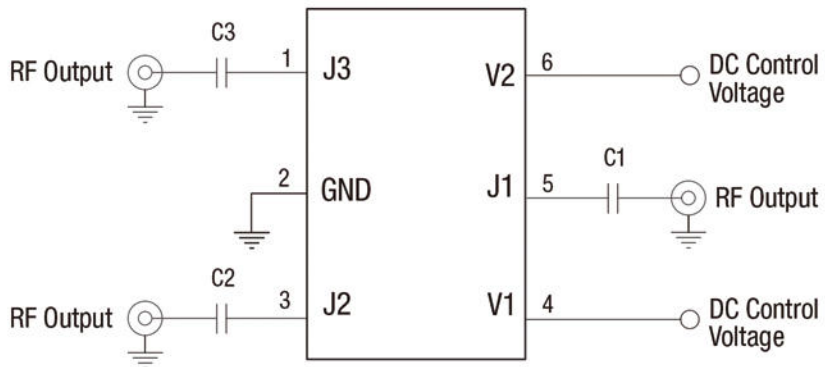

Figure 7. XA17-G4K Evaluation Board Assembly Diagram



Note: Use 100 pF blocking capacitors (C1, C2, C3) for >500 MHz operation. Higher values recommended for lower frequency operation. Exposed paddle must be grounded.

Use 10 nF blocking capacitors (C1, C2, C3) for <50 MHz operation.

Figure 6. XA17-G4K Evaluation Board Schematic

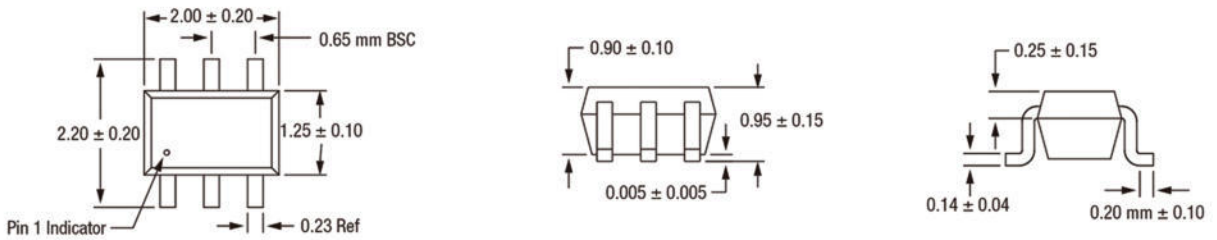

Notes:

All measurements are in millimeters.

Dimensions and tolerances according to ASME Y14.5M-1994.

Figure 8. XA17-G4K Package Dimensions

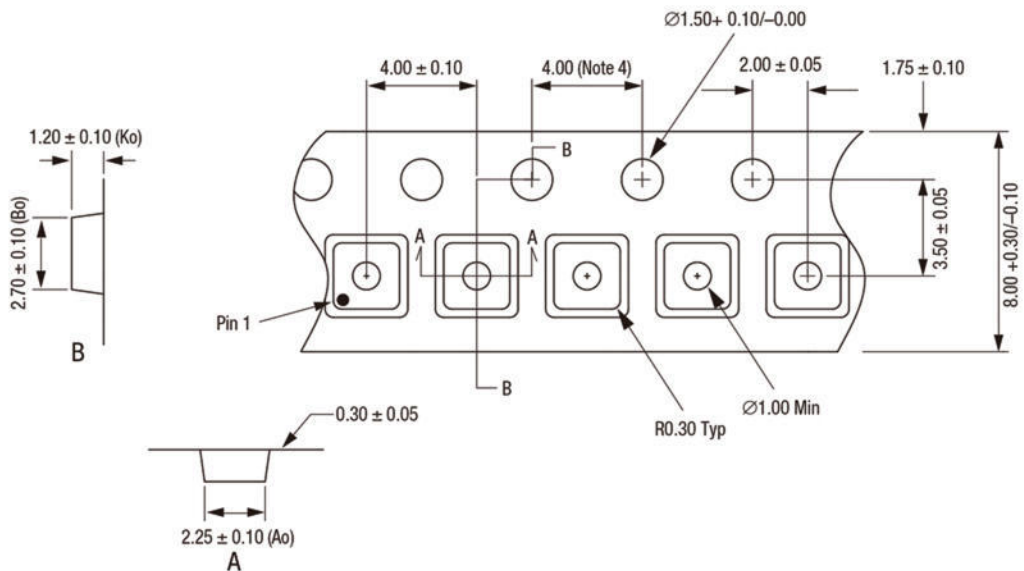

Notes:

1. Carrier tape: black conductive polystyrene.
2. Cover tape material: transparent conductive HSA.
3. Cover tape size: 5.40 mm width.
4. 10-sprocket hole pitch cumulative tolerance ± 0.20 mm.
5. All measurements are in millimeters.

Figure 9. XA17-G4K Tape and Reel Dimensions

Ordering Information

Model Name	Manufacturing Part Number	Evaluation Board Part Number
XA17-G4K : SPDT Switch	XA17-G4K	XA17-G4K-EVB

以上信息仅供参考. 如需帮助联系客服人员. 谢谢 XINLUDA

X-ON Electronics

Largest Supplier of Electrical and Electronic Components

Click to view similar products for [RF Switch ICs](#) category:

Click to view products by [XINLUDA](#) manufacturer:

Other Similar products are found below :

[MASW-007921-002SMB](#) [BGSA142GN12E6327XTSA1](#) [BGSA142MN12E6327XTSA1](#) [BGSA142M2N12E6327XTSA1](#) [MASW-004100-11930W](#) [MASW-008853-TR3000](#) [BGS13SN8E6327XTSA1](#) [BGSF18DM20E6327XUMA1](#) [BGSX210MA18E6327XTSA1](#) [BGSX212MA18E6327XTSA1](#) [SKY13446-374LF](#) [SW-227-PIN](#) [PE42524A-X](#) [CG2185X2](#) [CG2415M6](#) [MA4AGSW1A](#) [MA4AGSW2](#) [MA4AGSW3](#) [MA4AGSW5](#) [MA4SW210B-1](#) [MA4SW410](#) [MASW-002102-13580G](#) [BGS 12PL6 E6327](#) [BGS1414MN20E6327XTSA1](#) [BGS1515MN20E6327XTSA1](#) [BGSA11GN10E6327XTSA1](#) [BGSX28MA18E6327XTSA1](#) [HMC199AMS8](#) [HMC595AETR](#) [HMC986A](#) [SKY13374-397LF](#) [SKY13453-385LF](#) [CG2430X1-C2](#) [TGS4304](#) [UPG2162T5N-A](#) [CG2415M6-C2](#) [AS222-92LF](#) [SW-314-PIN](#) [UPG2162T5N-E2-A](#) [BGS18GA14E6327XTSA1](#) [MASWSS0204TR-3000](#) [MASWSS0201TR](#) [MASWSS0181TR-3000](#) [MASW-007588-TR3000](#) [MASW-007075-000100](#) [MASW-004103-13655P](#) [MASW-003102-13590G](#) [MASWSS0202TR-3000](#) [MASW-008543-TR3000](#) [MA4SW310B-1](#)