

XD124/XD224/XD324/XD2902N DIP14 XL124/XL224/XL324/XL2902 SOP14

FEATURES

- **2-kV ESD Protection for:**
 - XD224, XL224
 - XD324, XL324
 - XD2902, XL2902
- **Wide Supply Ranges**
 - **Single Supply:** 3 V to 32 V (26 V for XD2902)
 - **Dual Supplies:** ±1.5 V to ±16 V (±13 V for XL2902)
- **Low Supply-Current Drain Independent of Supply Voltage: 0.8 mA Typ**
- **Common-Mode Input Voltage Range Includes Ground, Allowing Direct Sensing Near Ground**
- **Low Input Bias and Offset Parameters**
 - **Input Offset Voltage:** 3 mV Typ
 A Versions: 2 mV Typ
 - **Input Offset Current:** 2 nA Typ
 - **Input Bias Current:** 20 nA Typ
 A Versions: 15 nA Typ
- **Differential Input Voltage Range Equal to Maximum-Rated Supply Voltage: 32 V (26 V for XD2902)**
- **Open-Loop Differential Voltage Amplification: 100 V/mV Typ**
- **Internal Frequency Compensation**
- **On Products Compliant to MIL-PRF-38535, All Parameters Are Tested Unless Otherwise Noted. On All Other Products, Production Processing Does Not Necessarily Include Testing of All Parameters.**

DESCRIPTION

These devices consist of four independent high-gain frequency-compensated operational amplifiers that are designed specifically to operate from a single supply over a wide range of voltages. Operation from split supplies also is possible if the difference between the two supplies is 3 V to 32 V (3 V to 26 V for the XD2902 device), and V_{CC} is at least 1.5 V more positive than the input common-mode voltage. The low supply-current drain is independent of the magnitude of the supply voltage.

Applications include transducer amplifiers, dc amplification blocks, and all the conventional operational-amplifier circuits that now can be more easily implemented in single-supply-voltage systems. For example, the XD124 device can be operated directly from the standard 5-V supply that is used in digital systems and provides the required interface electronics, without requiring additional ±15-V supplies.

XD124/XD224/XD324/XD2902N XL124/XL224/XL324/XL2902

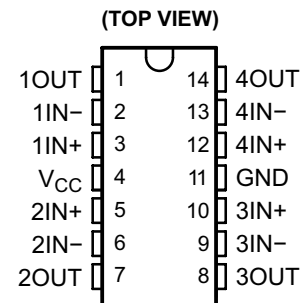

XD124/XD224/XD324/XD2902N DIP14 XL124/XL224/XL324/XL2902 SOP14

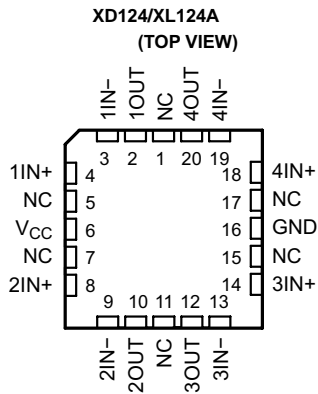

NC - No internal connection

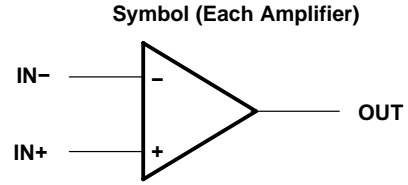

Schematic (Each Amplifier)

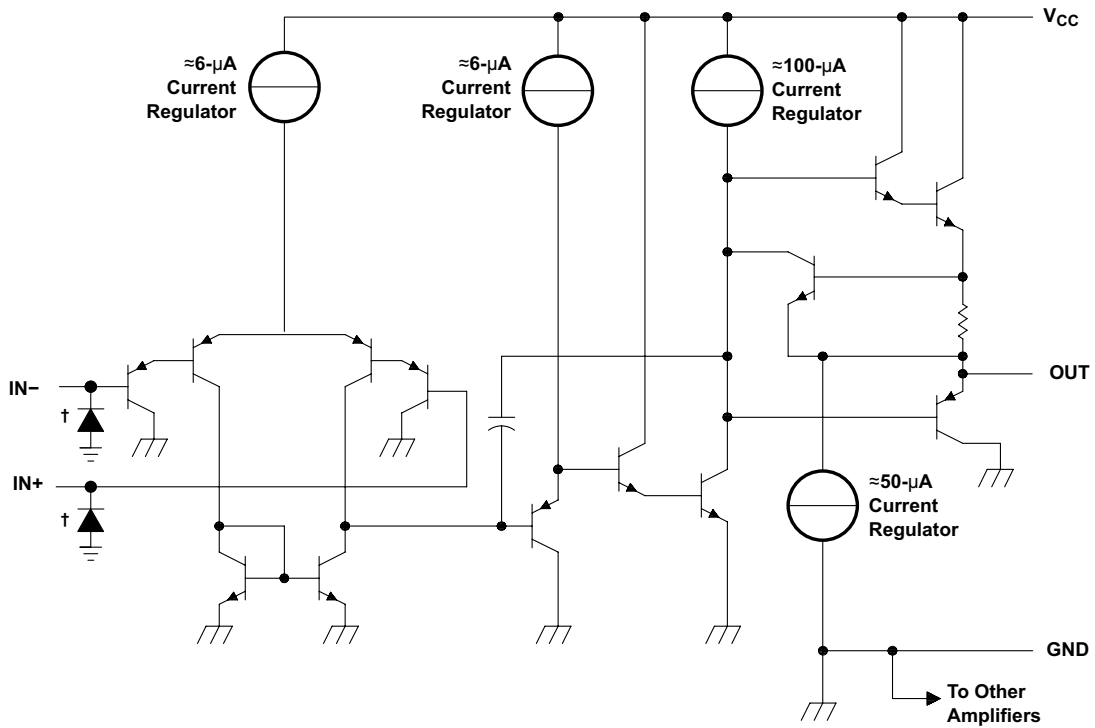

COMPONENT COUNT (total device)	
Epi-FET	1
Transistors	95
Diodes	4
Resistors	11
Capacitors	4

† ESD protection cells - available on XD324 and XL324 only

XD124/XD224/XD324/XD2902N DIP14 XL124/XL224/XL324/XL2902 SOP14

Absolute Maximum Ratings

over operating free-air temperature range (unless otherwise noted)⁽¹⁾

		XD2902	ALL OTHER DEVICES	UNIT
Supply voltage, V_{CC} ⁽²⁾		±13 or 26	±16 or 32	V
Differential input voltage, V_{ID} ⁽³⁾		±26	±32	V
Input voltage, V_I (either input)		-0.3 to 26	-0.3 to 32	V
Duration of output short circuit (one amplifier) to ground at (or below) $T_A = 25^\circ\text{C}$, $V_{CC} \leq 15\text{ V}$ ⁽⁴⁾		Unlimited	Unlimited	
Package thermal impedance, θ_{JA} ⁽⁴⁾⁽⁵⁾	D package	86	86	°C/W
	DB package	96	96	
	N package	80	80	
	NS package	76	76	
	PW package	113	113	
Package thermal impedance, θ_{JC} ⁽⁶⁾⁽⁷⁾	FK package		5.61	°C/W
	J package		15.05	
	W package		14.65	
Operating virtual junction temperature, T_J		150	150	°C
Case temperature for 60 seconds		FK package	260	°C
Lead temperature 1,6 mm (1/16 inch) from case for 60 seconds		J or W package	300	°C
Storage temperature range, T_{stg}		-65 to 150	-65 to 150	°C

- (1) Stresses beyond those listed under *Absolute Maximum Ratings* may cause permanent damage to the device. These are stress ratings only, and functional operation of the device at these or any other conditions beyond those indicated under *Recommended Operating Conditions* is not implied. Exposure to absolute-maximum-rated conditions for extended periods may affect device reliability.
- (2) All voltage values (except differential voltages and V_{CC} specified for the measurement of I_{OS}) are with respect to the network GND.
- (3) Differential voltages are at IN+, with respect to IN-.
- (4) Short circuits from outputs to V_{CC} can cause excessive heating and eventual destruction.
- (5) Maximum power dissipation is a function of $T_{J(max)}$, θ_{JA} , and T_A . The maximum allowable power dissipation at any allowable ambient temperature is $P_D = (T_{J(max)} - T_A)/\theta_{JA}$. Operating at the absolute maximum T_J of 150°C can affect reliability.
- (6) Maximum power dissipation is a function of $T_{J(max)}$, θ_{JA} , and T_C . The maximum allowable power dissipation at any allowable case temperature is $P_D = (T_{J(max)} - T_C)/\theta_{JC}$. Operating at the absolute maximum T_J of 150°C can affect reliability.
- (7) The package thermal impedance is calculated in accordance with MIL-STD-883

ESD Protection

TEST CONDITIONS		TYP	UNIT
Human-Body Model	XD224, XL224, XD324, XL324, XD2902, XL2902,	±2	kV

XD124/XD224/XD324/XD2902N DIP14 XL124/XL224/XL324/XL2902 SOP14

Electrical Characteristics

at specified free-air temperature, $V_{CC} = 5\text{ V}$ (unless otherwise noted)

PARAMETER	TEST CONDITIONS ⁽¹⁾	T_A ⁽²⁾	XD124, XD224			XD324 XL324			UNIT		
			MIN	TYP ⁽³⁾	MAX	MIN	TYP ⁽³⁾	MAX			
V_{IO} Input offset voltage	$V_{CC} = 5\text{ V to MAX}$, $V_{IC} = V_{ICRmin}$, $V_O = 1.4\text{ V}$	25°C		3	5		3	7	mV		
		Full range			7			9			
I_{IO} Input offset current	$V_O = 1.4\text{ V}$	25°C		2	30		2	50	nA		
		Full range			100			150			
I_{IB} Input bias current	$V_O = 1.4\text{ V}$	25°C		-20	-150		-20	-250	nA		
		Full range			-300			-500			
V_{ICR} Common-mode input voltage range	$V_{CC} = 5\text{ V to MAX}$	25°C		0 to $V_{CC} - 1.5$			0 to $V_{CC} - 1.5$		V		
		Full range		0 to $V_{CC} - 2$			0 to $V_{CC} - 2$				
V_{OH} High-level output voltage	$R_L = 2\text{ k}\Omega$	25°C		$V_{CC} - 1.5$			$V_{CC} - 1.5$			V	
		25°C		$V_{CC} - 1.5$			$V_{CC} - 1.5$				
	$V_{CC} = \text{MAX}$	$R_L = 2\text{ k}\Omega$	Full range		26			26			
		$R_L \geq 10\text{ k}\Omega$	Full range		27	28		27	28		
V_{OL} Low-level output voltage	$R_L \leq 10\text{ k}\Omega$	Full range		5	20		5	20	mV		
A_{VD} Large-signal differential voltage amplification	$V_{CC} = 15\text{ V}$, $V_O = 1\text{ V to }11\text{ V}$, $R_L \geq 2\text{ k}\Omega$	25°C		50	100		25	100	V/mV		
		Full range		25			15				
CMRR Common-mode rejection ratio	$V_{IC} = V_{ICRmin}$	25°C		70	80		65	80	dB		
k_{SVR} Supply-voltage rejection ratio ($\Delta V_{CC}/\Delta V_{IO}$)		25°C		65	100		65	100	dB		
V_{O1}/V_{O2} Crosstalk attenuation	$f = 1\text{ kHz to }20\text{ kHz}$	25°C		120			120			dB	
I_O Output current	$V_{CC} = 15\text{ V}$, $V_{ID} = 1\text{ V}$, $V_O = 0$	Source	25°C		-20	-30	-60	-20	-30	-60	mA
			Full range		-10			-10			
	$V_{CC} = 15\text{ V}$, $V_{ID} = -1\text{ V}$, $V_O = 15\text{ V}$	Sink	25°C		10	20		10	20		
			Full range		5			5			
	$V_{ID} = -1\text{ V}$, $V_O = 200\text{ mV}$	25°C		12	30		12	30	μA		
I_{OS} Short-circuit output current	V_{CC} at 5 V, $V_O = 0$, GND at -5 V	25°C		± 40	± 60		± 40	± 60	mA		
I_{CC} Supply current (four amplifiers)	$V_O = 2.5\text{ V}$, No load	Full range		0.7	1.2		0.7	1.2	mA		
	$V_{CC} = \text{MAX}$, $V_O = 0.5 V_{CC}$, No load	Full range		1.4	3		1.4	3			

- (1) All characteristics are measured under open-loop conditions, with zero common-mode input voltage, unless otherwise specified. MAX V_{CC} for testing purposes is 26 V for XD2902 and 30 V for the others.
- (2) Full range is -55°C to 125°C for LM124, -25°C to 85°C for LM224, and 0°C to 70°C for XD324.
- (3) All typical values are at $T_A = 25^\circ\text{C}$

XD124/XD224/XD324/XD2902N DIP14 XL124/XL224/XL324/XL2902 SOP14

Electrical Characteristics

at specified free-air temperature, $V_{CC} = 5\text{ V}$ (unless otherwise noted)

PARAMETER	TEST CONDITIONS ⁽¹⁾		T_A ⁽²⁾	XD2902			XL2902			UNIT
				MIN	TYP ⁽³⁾	MAX	MIN	TYP ⁽³⁾	MAX	
V_{IO} Input offset voltage	$V_{CC} = 5\text{ V to MAX,}$ $V_{IC} = V_{ICRmin},$ $V_O = 1.4\text{ V}$	Non-A-suffix devices	25°C	3 7			3 7			mV
			Full range	10			10			
		A-suffix devices	25°C				1 2			
			Full range				4			
$\Delta V_{IO}/\Delta T$ Input offset voltage temperature drift	$R_S = 0\ \Omega$		Full range				7			$\mu\text{V}/^\circ\text{C}$
I_{IO} Input offset current	$V_O = 1.4\text{ V}$		25°C	2 50			2 50			nA
			Full range	300			150			
$\Delta I_{IO}/\Delta T$ Input offset voltage temperature drift			Full range				10			$\text{pA}/^\circ\text{C}$
I_{IB} Input bias current	$V_O = 1.4\text{ V}$		25°C	-20 -250			-20 -250			nA
			Full range	-500			-500			
V_{ICR} Common-mode input voltage range	$V_{CC} = 5\text{ V to MAX}$		25°C	0 to $V_{CC} - 1.5$			0 to $V_{CC} - 1.5$			V
			Full range	0 to $V_{CC} - 2$			0 to $V_{CC} - 2$			
V_{OH} High-level output voltage	$R_L = 2\text{ k}\Omega$ $R_L = 10\text{ k}\Omega$ $V_{CC} = \text{MAX}$		25°C							V
			25°C	$V_{CC} - 1.5$			$V_{CC} - 1.5$			
		$R_L = 2\text{ k}\Omega$ $R_L \geq 10\text{ k}\Omega$	Full range	22			26			
			Full range	23 24			27			
V_{OL} Low-level output voltage	$R_L \leq 10\text{ k}\Omega$		Full range	5 20			5 20			mV
A_{VD} Large-signal differential voltage amplification	$V_{CC} = 15\text{ V,}$ $V_O = 1\text{ V to }11\text{ V,}$ $R_L \geq 2\text{ k}\Omega$		25°C	25 100			25 100			V/mV
			Full range	15			15			
CMRR Common-mode rejection ratio	$V_{IC} = V_{ICRmin}$		25°C	50 80			60 80			dB
k_{SVR} Supply-voltage rejection ratio ($\Delta V_{CC}/\Delta V_{IO}$)			25°C	50 100			60 100			dB
V_{O1}/V_{O2} Crosstalk attenuation	$f = 1\text{ kHz to }20\text{ kHz}$		25°C	120			120			dB
I_O Output current	$V_{CC} = 15\text{ V,}$ $V_{ID} = 1\text{ V,}$ $V_O = 0$	Source	25°C	-20 -30 -60			-20 -30 -60			mA
			Full range	-10			-10			
	$V_{CC} = 15\text{ V,}$ $V_{ID} = -1\text{ V,}$ $V_O = 15\text{ V}$	Sink	25°C	10 20			10 20			
			Full range	5			5			
	$V_{ID} = -1\text{ V, }V_O = 200\text{ mV}$		25°C	30			12 40			μA
I_{OS} Short-circuit output current	V_{CC} at 5 V, $V_O = 0$, GND at -5 V		25°C	± 40 ± 60			± 40 ± 60			mA
I_{CC} Supply current (four amplifiers)	$V_O = 2.5\text{ V, No load}$		Full range	0.7 1.2			0.7 1.2			mA
	$V_{CC} = \text{MAX, }V_O = 0.5 V_{CC},$ No load		Full range	1.4 3			1.4 3			

- (1) All characteristics are measured under open-loop conditions, with zero common-mode input voltage, unless otherwise specified. MAX V_{CC} for testing purposes is 26 V for XD2902 and 32 V for XL2902.
- (2) Full range is -40°C to 125°C for XD2902.
- (3) All typical values are at $T_A = 25^\circ\text{C}$.

XD124/XD224/XD324/XD2902N DIP14 XL124/XL224/XL324/XL2902 SOP14

Electrical Characteristics

at specified free-air temperature, $V_{CC} = 5\text{ V}$ (unless otherwise noted)

PARAMETER	TEST CONDITIONS ⁽¹⁾		T_A ⁽²⁾	XD124			XD224			XD324, XL324			UNIT						
				MIN	TYP ⁽³⁾	MAX	MIN	TYP ⁽³⁾	MAX	MIN	TYP ⁽³⁾	MAX							
V_{IO} Input offset voltage	$V_{CC} = 5\text{ V to }30\text{ V}$, $V_{IC} = V_{ICRmin}$, $V_O = 1.4\text{ V}$		25°C			2		2	3		2	3	mV						
			Full range			4		4				5							
I_{IO} Input offset current	$V_O = 1.4\text{ V}$		25°C					2	15		2	30	nA						
			Full range					30	30			75							
I_{IB} Input bias current	$V_O = 1.4\text{ V}$		25°C			-50		-15	-80		-15	-100	nA						
			Full range			-100		-100				-200							
V_{ICR} Common-mode input voltage range	$V_{CC} = 30\text{ V}$		25°C	0 to $V_{CC} - 1.5$			0 to $V_{CC} - 1.5$			0 to $V_{CC} - 1.5$			V						
			Full range	0 to $V_{CC} - 2$			0 to $V_{CC} - 2$			0 to $V_{CC} - 2$									
V_{OH} High-level output voltage	$R_L = 2\text{ k}\Omega$ $V_{CC} = 30\text{ V}$	$R_L = 2\text{ k}\Omega$ $R_L \geq 10\text{ k}\Omega$	25°C	$V_{CC} - 1.5$			$V_{CC} - 1.5$			$V_{CC} - 1.5$			V						
			Full range	26			26			26									
V_{OL} Low-level output voltage	$R_L \leq 10\text{ k}\Omega$		25°C	20			5			20			mV						
			Full range	20			5			20									
A_{VD} Large-signal differential voltage amplification	$V_{CC} = 15\text{ V}$, $V_O = 1\text{ V to }11\text{ V}$, $R_L \geq 2\text{ k}\Omega$		25°C	50	100		50	100		25	100		V/mV						
			Full range	25			25			15									
CMRR	$V_{IC} = V_{ICRmin}$		25°C	70			70	80		65	80		dB						
k_{SVR}	Supply-voltage rejection ratio ($\Delta V_{CC} / \Delta V_{IO}$)		25°C	65			65	100		65	100		dB						
V_{O1} / V_{O2}	Crosstalk attenuation		$f = 1\text{ kHz to }20\text{ kHz}$	25°C	120			120			120			dB					
I_O Output current	$V_{CC} = 15\text{ V}$, $V_{ID} = 1\text{ V}$, $V_O = 0$	Source	25°C	-20			-20			-30			-60			mA			
			Full range	-10			-10			-10									
		Sink	25°C	10			10			20			1				20		
			Full range	5			5			5			5						
I_{OS} Short-circuit output current	V_{CC} at 5 V, GND at -5 V, $V_O = 0$		25°C	± 40			± 40			± 40			± 60			mA			
			Full range	± 40			± 40			± 40			± 60						
I_{CC} Supply current (four amplifiers)	$V_O = 2.5\text{ V}$, No load		Full range	0.7			1.2			0.7			1.2			mA			
	$V_{CC} = 30\text{ V}$, $V_O = 15\text{ V}$, No load		Full range	1.4			3			1.4			3						

- (1) All characteristics are measured under open-loop conditions, with zero common-mode input voltage, unless otherwise specified.
(2) Full range is -55°C to 125°C for XD124A, -25°C to 85°C for XD224, and 0°C to 70°C for XD324.
(3) All typical values are at $T_A = 25^\circ\text{C}$.

XD124/XD224/XD324/XD2902N DIP14 XL124/XL224/XL324/XL2902 SOP14

Operating Conditions

$V_{CC} = \pm 15\text{ V}$, $T_A = 25^\circ\text{C}$

PARAMETER	TEST CONDITIONS	TYP	UNIT
SR Slew rate at unity gain	$R_L = 1\text{ M}\Omega$, $C_L = 30\text{ pF}$, $V_I = \pm 10\text{ V}$ (see Figure 1)	0.5	V/ μs
B_1 Unity-gain bandwidth	$R_L = 1\text{ M}\Omega$, $C_L = 20\text{ pF}$ (see Figure 1)	1.2	MHz
V_n Equivalent input noise voltage	$R_S = 100\ \Omega$, $V_I = 0\text{ V}$, $f = 1\text{ kHz}$ (see Figure 2)	35	nV/ $\sqrt{\text{Hz}}$

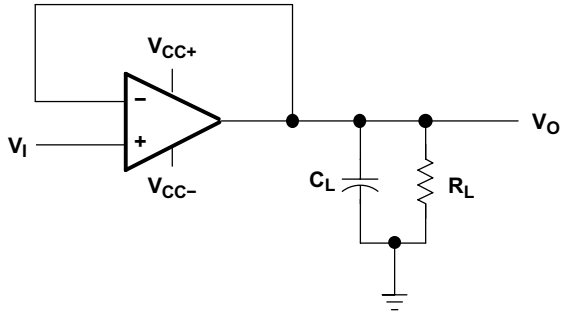

Figure 1. Unity-Gain Amplifier

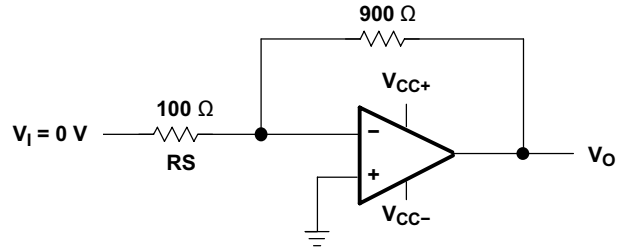

Figure 2. Noise-Test Circuit

以上信息仅供参考. 如需帮助联系客服人员。谢谢 XINLUDA

X-ON Electronics

Largest Supplier of Electrical and Electronic Components

Click to view similar products for [Operational Amplifiers - Op Amps](#) category:

Click to view products by [XINLUDA](#) manufacturer:

Other Similar products are found below :

[OPA2991IDSGR](#) [OPA607IDCKT](#) [007614D](#) [633773R](#) [635798C](#) [635801A](#) [702115D](#) [709228FB](#) [741528D](#) [NCV33072ADR2G](#)
[SC2902DTBR2G](#) [SC2903DR2G](#) [SC2903VDR2G](#) [LM258AYDT](#) [LM358SNG](#) [430227FB](#) [430228DB](#) [460932C](#) [AZV831KTR-G1](#) [409256CB](#)
[430232AB](#) [LM2904DR2GH](#) [LM358YDT](#) [LT1678IS8](#) [042225DB](#) [058184EB](#) [070530X](#) [SC224DR2G](#) [SC239DR2G](#) [SC2902DG](#)
[SCYA5230DR2G](#) [714228XB](#) [714846BB](#) [873836HB](#) [MIC918YC5-TR](#) [TS912BIYDT](#) [NCS2004MUTAG](#) [NCV33202DMR2G](#)
[M38510/13101BPA](#) [NTE925](#) [SC2904DR2G](#) [SC358DR2G](#) [LM358EDR2G](#) [AZV358MTR-G1](#) [AP4310AUMTR-AG1](#) [HA1630D02MMEL-E](#)
[NJM358CG-TE2](#) [HA1630S01LPEL-E](#) [LM324AWPT](#) [HA1630Q06TELL-E](#)