

XD13700 DIP16 / XL13700 SOP16

1 Features

- g_m Adjustable Over 6 Decades
- Excellent g_m Linearity
- Excellent Matching Between Amplifiers
- Linearizing Diodes for reduced output distortion
- High Impedance Buffers
- High Output Signal-to-Noise Ratio

2 Applications

- Current-Controlled Amplifiers
- Stereo Audio Amplifiers
- Current-Controlled Impedances
- Current-Controlled Filters
- Current-Controlled Oscillators
- Multiplexers
- Timers
- Sample-and-Hold Circuits

3 Description

The XD13700 series consists of two current-controlled transconductance amplifiers, each with differential inputs and a push-pull output. The two amplifiers share common supplies but otherwise operate independently. Linearizing diodes are provided at the inputs to reduce distortion and allow higher input levels. The result is a 10-dB signal-to-noise improvement referenced to 0.5 percent THD. High impedance buffers are provided which are especially designed to complement the dynamic range of the amplifiers. The output buffers of the XD13700 differ from those of the XL13700 in that their input bias currents (and thus their output DC levels) are independent of I_{ABC} . This may result in performance superior to that of the XL13700 in audio applications.

Device Information⁽¹⁾

PART NUMBER	PACKAGE	BODY SIZE (NOM)
13700	SOIC (16)	3.91 mm × 9.90 mm
	PDIP (16)	6.35 mm × 19.304 mm

Connection Diagram

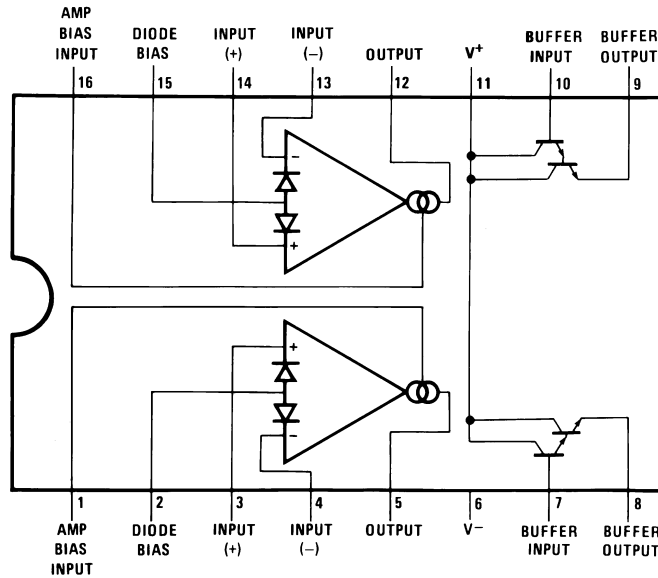

XD13700 DIP16 / XL13700 SOP16

5 Pin Configuration and Functions

**D or NFG Package
16-Pin SOIC or PDIP
Top View**

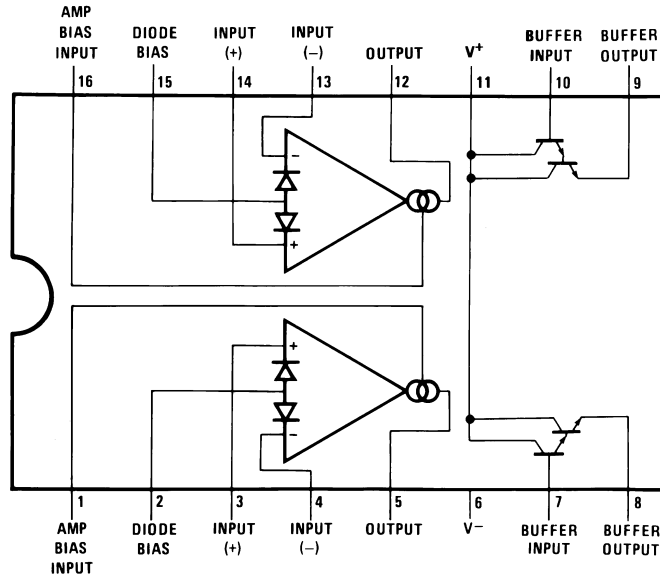

Pin Functions

PIN		I/O	DESCRIPTION
NAME	NO.		
Amp bias input	1, 16	A	Current bias input
Buffer input	7, 10	A	Buffer amplifier input
Buffer output	8, 9	A	Buffer amplifier output
Diode bias	2, 15	A	Linearizing diode bias input
Input+	3, 14	A	Positive input
Input-	4, 13	A	Negative input
Output	5, 12	A	Unbuffered output
V ⁺	11	P	Positive power supply
V ⁻	6	P	Negative power supply

XD13700 DIP16 / XL13700 SOP16

6 Specifications

6.1 Absolute Maximum Ratings

over operating free-air temperature range (unless otherwise noted)⁽¹⁾

	MIN	MAX	UNIT
Supply voltage		36 V _{DC} or ±18	V
DC input voltage	+V _S	-V _S	V
Differential input voltage		±5	V
Diode bias current (I _D)		2	mA
Amplifier bias current (I _{ABC})		2	mA
Buffer output current ⁽²⁾		20	mA
Power dissipation ⁽³⁾ T _A = 25°C – XD13700		570	mW
Output short circuit duration		Continuous	
Storage temperature, T _{stg}	-65	150	°C

(1) Stresses beyond those listed under *Absolute Maximum Ratings* may cause permanent damage to the device. These are stress ratings only, which do not imply functional operation of the device at these or any other conditions beyond those indicated under *Recommended Operating Conditions*. Exposure to absolute-maximum-rated conditions for extended periods may affect device reliability.

(2) Buffer output current should be limited so as to not exceed package dissipation.

(3) For operation at ambient temperatures above 25°C, the device must be derated based on a 150°C maximum junction temperature and a thermal resistance, junction to ambient, as follows: XD13700, 90°C/W; XL13700, 110°C/W.

6.2 Recommended Operating Conditions

over operating free-air temperature range (unless otherwise noted)

		MIN	MAX	UNIT
V+ (single-supply configuration)		9.5	32	V
V+ (dual-supply configuration)		4.75	16	V
V- (dual-supply configuration)		-16	-4.75	V
Operating temperature, T _A	XD13700	0	70	°C

6.3 Thermal Information

THERMAL METRIC ⁽¹⁾		XD13700		UNIT
		D (SOIC)	NFG (PDIP)	
		16 PINS	16 PINS	
R _{θJA}	Junction-to-ambient thermal resistance	83.0	43.8	°C/W
R _{θJC(top)}	Junction-to-case (top) thermal resistance	44.0	34.9	°C/W
R _{θJB}	Junction-to-board thermal resistance	40.5	28.3	°C/W
Ψ _{JT}	Junction-to-top characterization parameter	11.5	19.1	°C/W
Ψ _{JB}	Junction-to-board characterization parameter	40.2	28.2	°C/W

XD13700 DIP16 / XL13700 SOP16

6.4 Electrical Characteristics

These specifications apply for $V_S = \pm 15\text{ V}$, $T_A = 25^\circ\text{C}$, amplifier bias current (I_{ABC}) = 500 μA , pins 2 and 15 open unless otherwise specified. The inputs to the buffers are grounded and outputs are open.

PARAMETER	TEST CONDITIONS	MIN	TYP	MAX	UNIT
Input offset voltage (V_{OS})	Over specified temperature range		0.4	4	mV
	$I_{ABC} = 5\ \mu\text{A}$		0.3	4	
V_{OS} including diodes	Diode bias current (I_D) = 500 μA		0.5	5	mV
Input offset change	$5\ \mu\text{A} \leq I_{ABC} \leq 500\ \mu\text{A}$		0.1	3	mV
Input offset current			0.1	0.6	μA
Input bias current			0.4	5	μA
	Over specified temperature range		1	8	
Forward transconductance (g_m)		6700	9600	13000	μS
	Over specified temperature range	5400			
g_m tracking			0.3		dB
Peak output current	$R_L = 0$, $I_{ABC} = 5\ \mu\text{A}$		5		μA
	$R_L = 0$, $I_{ABC} = 500\ \mu\text{A}$	350	500	650	
	$R_L = 0$, Over Specified Temp Range	300			
Supply current	$I_{ABC} = 500\ \mu\text{A}$, both channels		2.6		mA
CMRR		80	110		dB
Common-mode range		± 12	± 13.5		V
Crosstalk	Referred to input ⁽¹⁾ 20 Hz < f < 20 kHz		100		dB
Differential input current	$I_{ABC} = 0$, input = $\pm 4\text{ V}$		0.02	100	nA
Leakage current	$I_{ABC} = 0$ (refer to test circuit)		0.2	100	nA
Input resistance		10	26		k Ω
Open-loop bandwidth			2		MHz
Slew rate	Unity gain compensated		50		V/ μs
Buffer input current	See ⁽¹⁾		0.5	2	μA
Peak buffer output voltage	See ⁽¹⁾	10			V
PEAK OUTPUT VOLTAGE					
Positive	$R_L = \infty$, $5\ \mu\text{A} \leq I_{ABC} \leq 500\ \mu\text{A}$	12	14.2		V
Negative	$R_L = \infty$, $5\ \mu\text{A} \leq I_{ABC} \leq 500\ \mu\text{A}$	-12	-14.4		V
V_{OS} SENSITIVITY					
Positive	$\Delta V_{OS}/\Delta V^+$		20	150	$\mu\text{V}/\text{V}$
Negative	$\Delta V_{OS}/\Delta V^-$		20	150	$\mu\text{V}/\text{V}$

(1) These specifications apply for $V_S = \pm 15\text{ V}$, $I_{ABC} = 500\ \mu\text{A}$, $R_{OUT} = 5\text{-k}\Omega$ connected from the buffer output to $-V_S$ and the input of the buffer is connected to the transconductance amplifier output.

6.5 Typical Characteristics

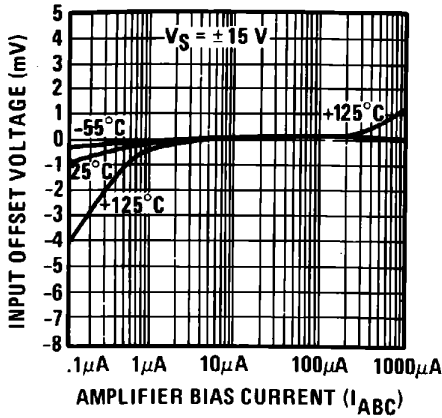

Figure 1. Input Offset Voltage

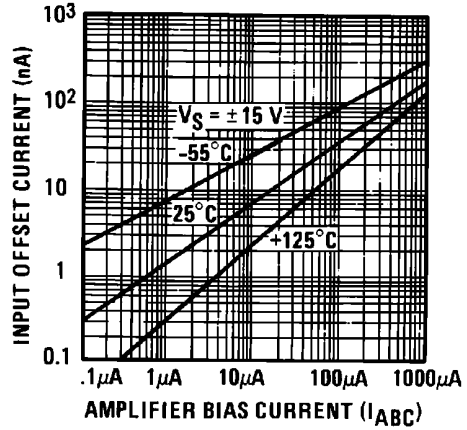

Figure 2. Input Offset Current

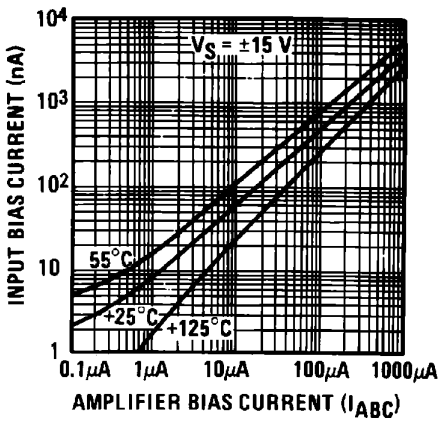

Figure 3. Input Bias Current

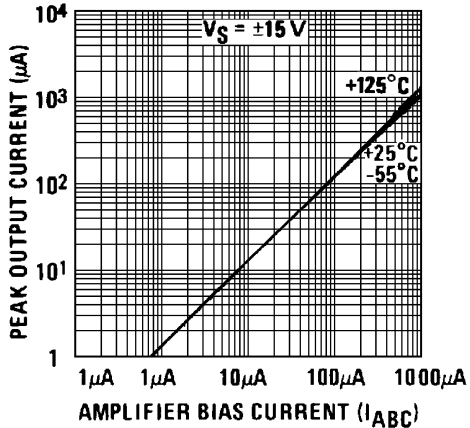

Figure 4. Peak Output Current

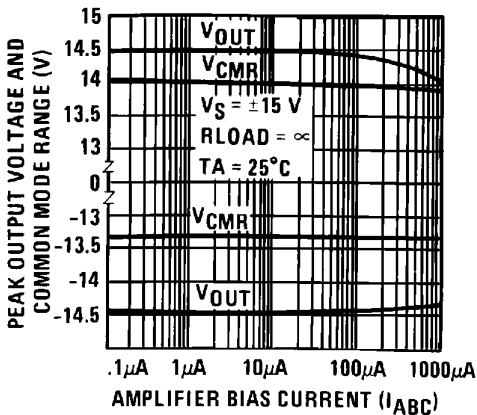

Figure 5. Peak Output Voltage and Common Mode Range

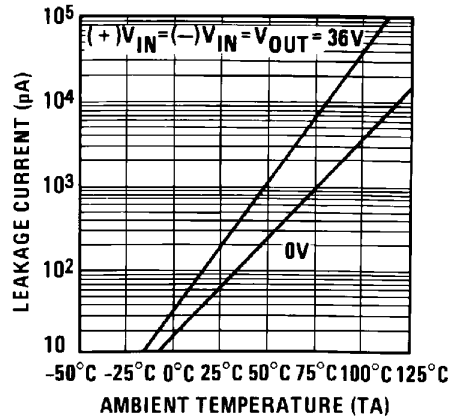

Figure 6. Leakage Current

Typical Characteristics (continued)

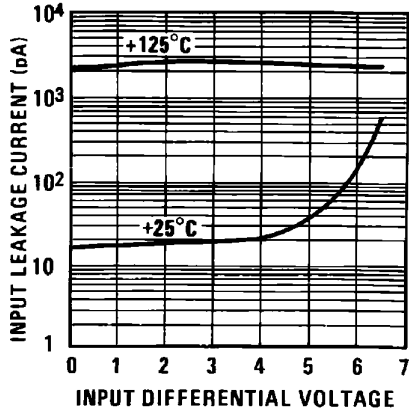

Figure 7. Input Leakage

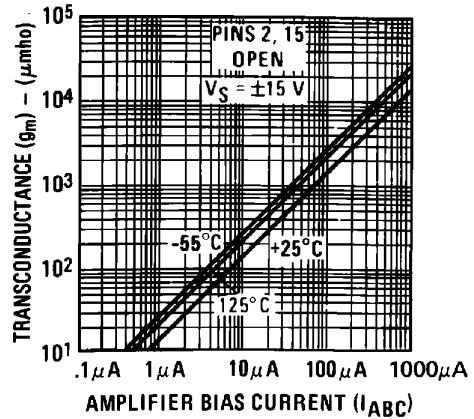

Figure 8. Transconductance

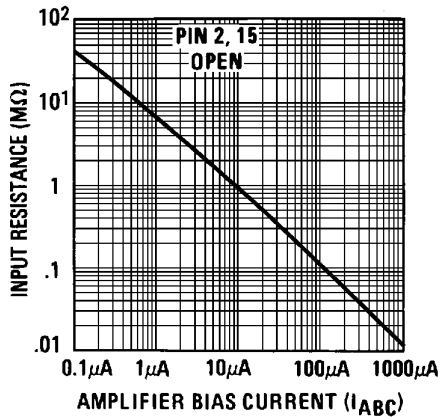

Figure 9. Input Resistance

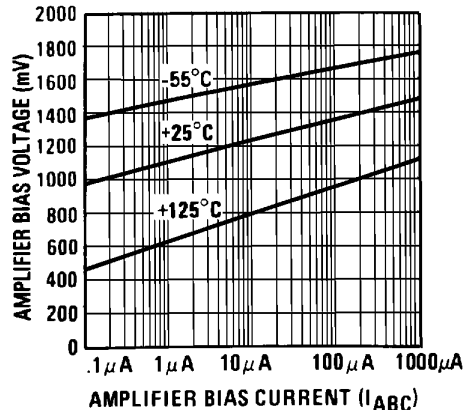

Figure 10. Amplifier Bias Voltage vs. Amplifier Bias Current

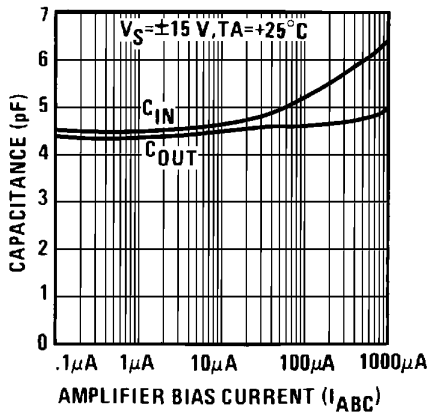

Figure 11. Input and Output Capacitance

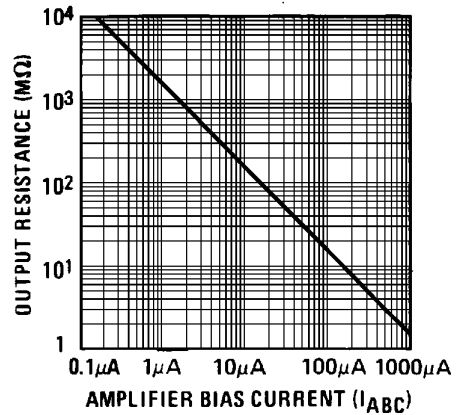

Figure 12. Output Resistance

Typical Characteristics (continued)

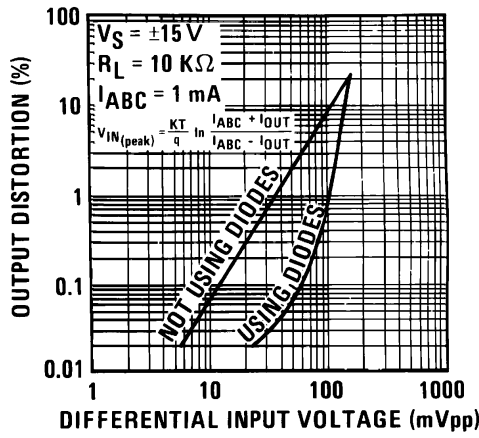

Figure 13. Distortion vs. Differential Input Voltage

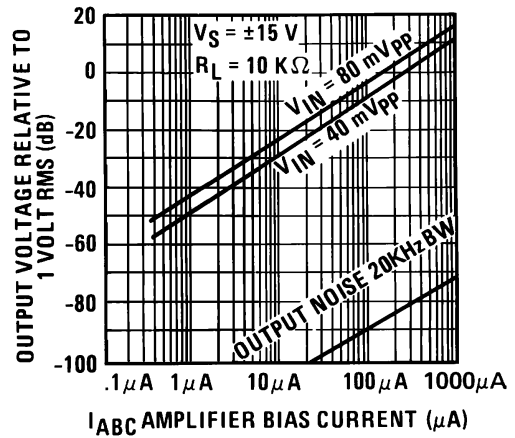

Figure 14. Voltage vs. Amplifier Bias Current

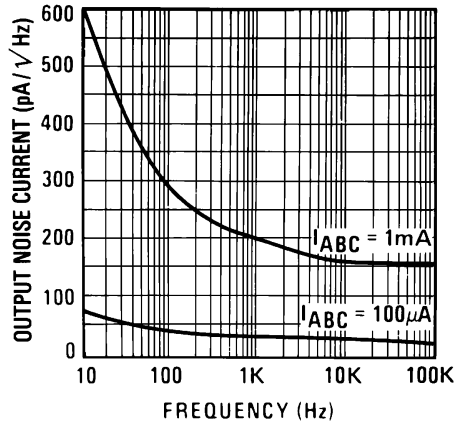

Figure 15. Output Noise vs Frequency

7 Detailed Description

7.1 Overview

The XD13700 is a two channel current controlled differential input transconductance amplifier with additional output buffers. The inputs include linearizing diodes to reduce distortion, and the output current is controlled by a dedicated pin. The outputs can sustain a continuous short to ground.

7.2 Functional Block Diagram

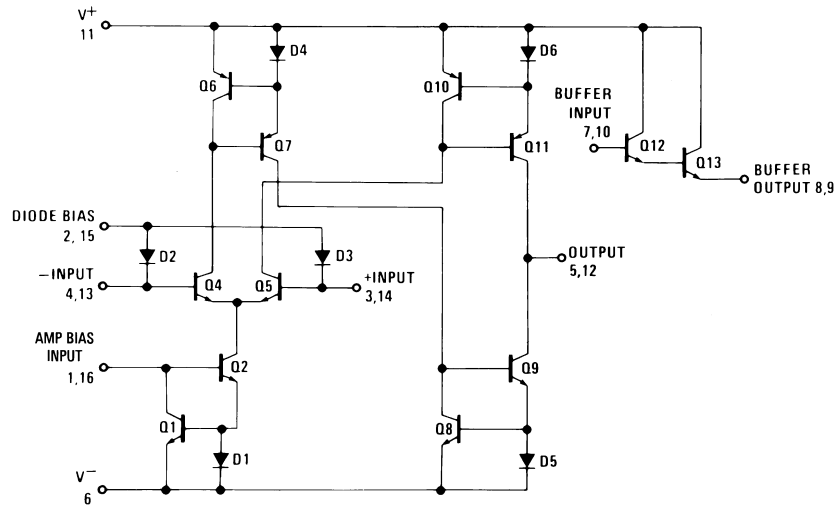

Figure 16. One Operational Transconductance Amplifier

7.3 Feature Description

7.3.1 Circuit Description

The differential transistor pair Q_4 and Q_5 form a transconductance stage in that the ratio of their collector currents is defined by the differential input voltage according to the transfer function:

$$V_{IN} = \frac{kT}{q} \ln \frac{I_5}{I_4} \quad (1)$$

where V_{IN} is the differential input voltage, kT/q is approximately 26 mV at 25°C and I_5 and I_4 are the collector currents of transistors Q_5 and Q_4 respectively. With the exception of Q_{12} and Q_{13} , all transistors and diodes are identical in size. Transistors Q_1 and Q_2 with Diode D_1 form a current mirror which forces the sum of currents I_4 and I_5 to equal I_{ABC} :

$$I_4 + I_5 = I_{ABC} \quad (2)$$

where I_{ABC} is the amplifier bias current applied to the gain pin.

For small differential input voltages the ratio of I_4 and I_5 approaches unity and the Taylor series of the \ln function is approximated as:

$$\begin{aligned} \frac{kT}{q} \ln \frac{I_5}{I_4} &\approx \frac{kT}{q} \frac{I_5 - I_4}{I_4} \\ I_4 \approx I_5 &\approx \frac{I_{ABC}}{2} \end{aligned} \quad (3)$$

$$V_{IN} \left[\frac{I_{ABC}^q}{2kT} \right] = I_5 - I_4 \quad (4)$$

Feature Description (continued)

Collector currents I_4 and I_5 are not very useful by themselves and it is necessary to subtract one current from the other. The remaining transistors and diodes form three current mirrors that produce an output current equal to I_5 minus I_4 thus:

$$V_{IN} \left[\frac{I_{ABC}^q}{2kT} \right] = I_{OUT} \quad (5)$$

The term in brackets is then the transconductance of the amplifier and is proportional to I_{ABC} .

7.3.2 Linearizing Diodes

For differential voltages greater than a few millivolts, Equation 3 becomes less valid and the transconductance becomes increasingly nonlinear. Figure 19 demonstrates how the internal diodes can linearize the transfer function of the amplifier. For convenience assume the diodes are biased with current sources and the input signal is in the form of current I_S . Since the sum of I_4 and I_5 is I_{ABC} and the difference is I_{OUT} , currents I_4 and I_5 is written as follows:

$$I_4 = \frac{I_{ABC}}{2} - \frac{I_{OUT}}{2}, \quad I_5 = \frac{I_{ABC}}{2} + \frac{I_{OUT}}{2} \quad (6)$$

Since the diodes and the input transistors have identical geometries and are subject to similar voltages and temperatures, the following is true:

$$\frac{kT}{q} \ln \frac{\frac{I_D}{2} + I_S}{\frac{I_D}{2} - I_S} = \frac{kT}{q} \ln \frac{\frac{I_{ABC}}{2} + \frac{I_{OUT}}{2}}{\frac{I_{ABC}}{2} - \frac{I_{OUT}}{2}}$$

$$\therefore I_{OUT} = I_S \left(\frac{2I_{ABC}}{I_D} \right) \text{ for } |I_S| < \frac{I_D}{2} \quad (7)$$

Notice that in deriving Equation 7 no approximations have been made and there are no temperature-dependent terms. The limitations are that the signal current not exceed $I_D / 2$ and that the diodes be biased with currents. In practice, replacing the current sources with resistors will generate insignificant errors.

7.4 Device Functional Modes

Use in single ended or dual supply systems requires minimal changes. The outputs can support a sustained short to ground. Note that use of the XD13700 in ± 5 V supply systems requires will reduce signal dynamic range; this is due to the PNP transistors having a higher V_{BE} than the NPN transistors.

7.4.1 Output Buffers

Each channel includes a separate output buffer which consists of a Darlington pair transistor that can drive up to 20mA.

8 Application and Implementation

8.1 Application Information

An OTA is a versatile building block analog component that can be considered an ideal transistor. The XD13700 can be used in a wide variety of applications, from voltage-controlled amplifiers and filters to VCOs. The 2 well-matched, independent channels make the XL13700 well suited for stereo audio applications.

8.2 Typical Application

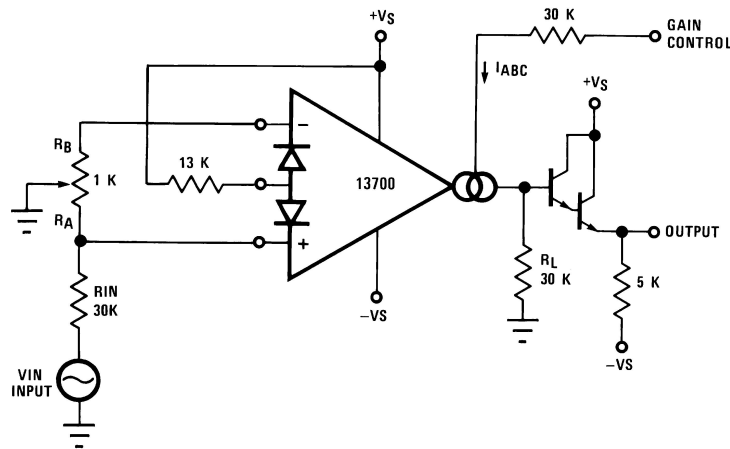

Figure 17. Voltage Controlled Amplifier

8.2.1 Design Requirements

For this example application, the system requirements provide a volume control for a $1 V_P$ input signal with a THD < 0.1% using $\pm 15 V$ supplies. The volume control varies between -13 V and 15 V and needs to provide an adjustable gain range of >30dB.

8.2.2 Detailed Design Procedure

Using the linearizing diodes is recommended for most applications, as they greatly reduce the output distortion. It is required that the diode bias current, I_D be greater than twice the input current, I_S . As the input voltage has a DC level of 0 V, the Diode Bias input pins are 1 diode drop above 0 V, which is +0.7 V. Tying the bias to the clean V_+ supply, results in a voltage drop of 14.3 V across R_D . Using the recommended 1mA for I_D is appropriate here, and with $V_S = +15 V$, the voltage drop is 14.3 V, and so using the standard value of 13-k Ω is acceptable and will provide the desired gain control.

To obtain the <0.1% THD requirement, the differential input voltage must be <60mV_{pp} when the linearizing diodes are used. The input divider on the input will reduce the $1 V_P$ input to 33mV_{pp}, which is within the desired spec.

Next, set I_{BIAS} . The Bias Input pins (pins 1 or 16), are 2 diode drops above the negative supply, and therefore $V_{BIAS} = 2(V_{BE}) + V_-$, which for this application is -13.6 V. To set I_{BIAS} to 1ma when $V_C = 15 V$ requires a 28.6-k Ω ; 30-k Ω is a standard value and is used for this application. The gain will be linear with the applied voltage.

Typical Application (continued)

8.2.3 Application Curve

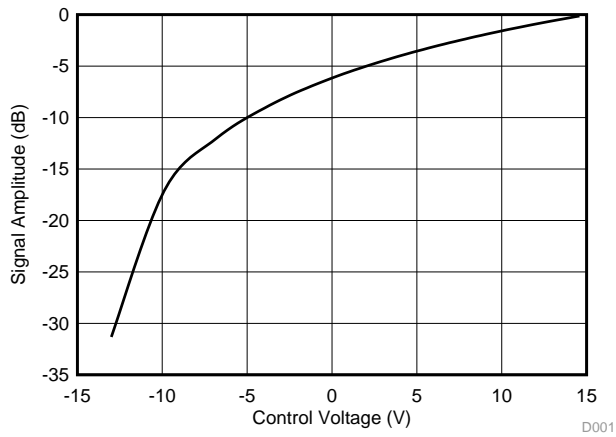

Figure 18. Signal Amplitude vs Control Voltage

8.3 System Examples

8.3.1 Voltage-Controlled Amplifiers

Figure 20 shows how the linearizing diodes is used in a voltage-controlled amplifier. To understand the input biasing, it is best to consider the 13-kΩ resistor as a current source and use a Thevenin equivalent circuit as shown in Figure 21. This circuit is similar to Figure 19 and operates the same. The potentiometer in Figure 20 is adjusted to minimize the effects of the control signal at the output.

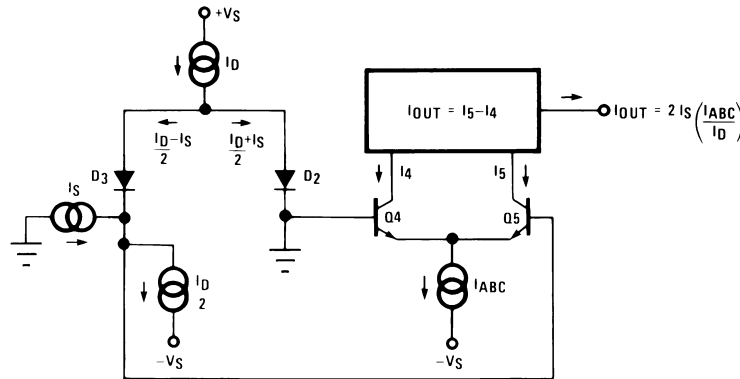

Figure 19. Linearizing Diodes

For optimum signal-to-noise performance, I_{ABC} should be as large as possible as shown by the Output Voltage vs Amplifier Bias Current graph. Larger amplitudes of input signal also improve the S/N ratio. The linearizing diodes help here by allowing larger input signals for the same output distortion as shown by the Distortion vs. Differential Input Voltage graph. S/N may be optimized by adjusting the magnitude of the input signal via R_{IN} (Figure 20) until the output distortion is below the desired level. The output voltage swing can then be set at any level by selecting R_L .

Although the noise contribution of the linearizing diodes is negligible relative to the contribution of the amplifier's internal transistors, I_D should be as large as possible. This minimizes the dynamic junction resistance of the diodes (r_e) and maximizes their linearizing action when balanced against R_{IN} . A value of 1 mA is recommended for I_D unless the specific application demands otherwise.

X-ON Electronics

Largest Supplier of Electrical and Electronic Components

Click to view similar products for [Operational Amplifiers - Op Amps](#) category:

Click to view products by [XINLUDA](#) manufacturer:

Other Similar products are found below :

[OPA2991IDSGR](#) [OPA607IDCKT](#) [007614D](#) [633773R](#) [635798C](#) [635801A](#) [702115D](#) [709228FB](#) [741528D](#) [NCV33072ADR2G](#)
[SC2902DTBR2G](#) [SC2903DR2G](#) [SC2903VDR2G](#) [LM258AYDT](#) [LM358SNG](#) [430227FB](#) [430228DB](#) [460932C](#) [AZV831KTR-G1](#) [409256CB](#)
[430232AB](#) [LM2904DR2GH](#) [LM358YDT](#) [LT1678IS8](#) [042225DB](#) [058184EB](#) [070530X](#) [SC224DR2G](#) [SC239DR2G](#) [SC2902DG](#)
[SCYA5230DR2G](#) [714228XB](#) [714846BB](#) [873836HB](#) [MIC918YC5-TR](#) [TS912BIYDT](#) [NCS2004MUTAG](#) [NCV33202DMR2G](#)
[M38510/13101BPA](#) [NTE925](#) [SC2904DR2G](#) [SC358DR2G](#) [LM358EDR2G](#) [AZV358MTR-G1](#) [AP4310AUMTR-AG1](#) [HA1630D02MMEL-E](#)
[NJM358CG-TE2](#) [HA1630S01LPEL-E](#) [LM324AWPT](#) [HA1630Q06TELL-E](#)