

# XD331 DIP-8 / XL331 SOP8 / XD231 DIP-8

## 1 Features

- Ensured Linearity 0.01% Maximum
- Improved Performance in Existing Voltage-to-Frequency Conversion Applications
- Split or Single-Supply Operation
- Operates on Single 5-V Supply
- Pulse Output Compatible With All Logic Forms
- Excellent Temperature Stability:  $\pm 50$  ppm/ $^{\circ}\text{C}$  Maximum
- Low Power Consumption: 15 mW Typical at 5 V
- Wide Dynamic Range, 100 dB Minimum at 10-kHz Full Scale Frequency
- Wide Range of Full Scale Frequency: 1 Hz to 100 kHz
- Low-Cost

## 2 Applications

- Voltage to Frequency Conversions
- Frequency to Voltage Conversions
- Remote-Sensor Monitoring
- Tachometers

## 3 Description

The XDx31 family of voltage-to-frequency converters are ideally suited for use in simple low-cost circuits for analog-to-digital conversion, precision frequency-to-voltage conversion, long-term integration, linear frequency modulation or demodulation, and many other functions. The output when used as a voltage-to-frequency converter is a pulse train at a frequency precisely proportional to the applied input voltage. Thus, it provides all the inherent advantages of the voltage-to-frequency conversion techniques, and is easy to apply in all standard voltage-to-frequency converter applications.

## 4 Device Information<sup>(1)</sup>

PART NUMBER	PACKAGE
XD331-231	DIP8
XL331	SOP8

**Schematic Diagram**

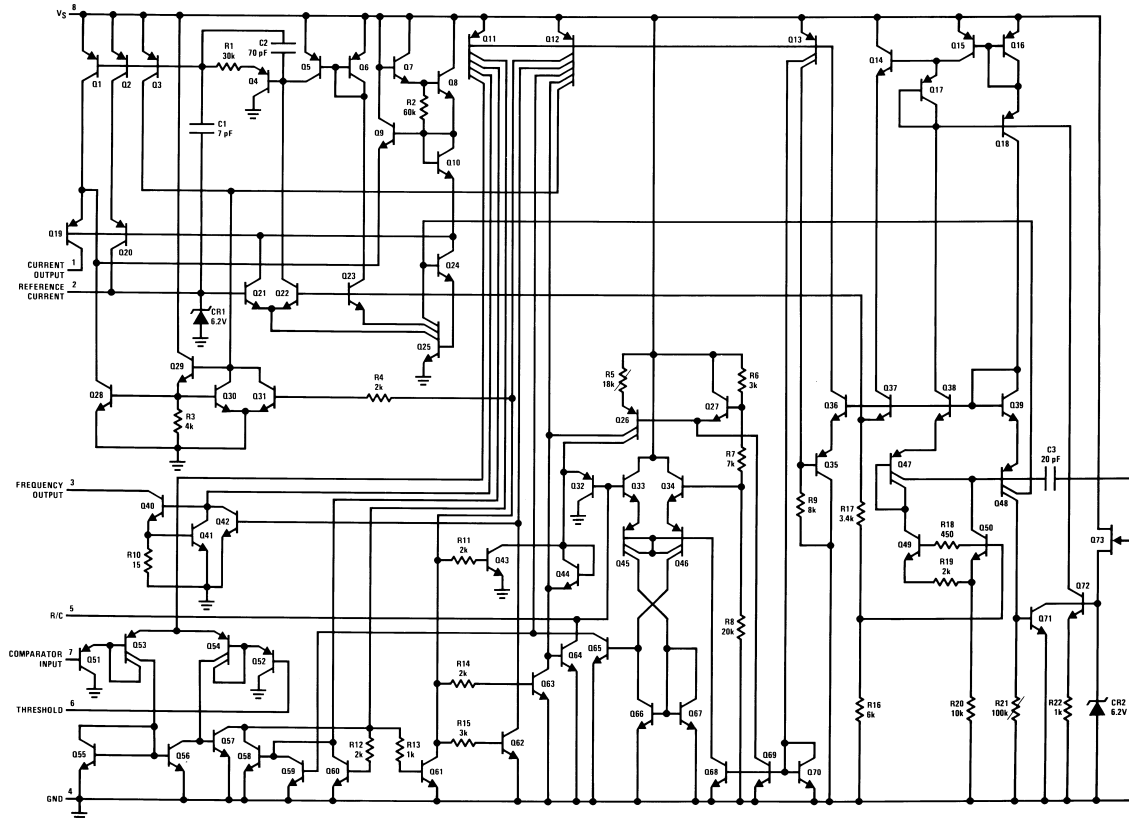

# XD331 DIP-8 / XL331 SOP8 / XD231 DIP-8

## 5 Pin Configuration and Functions

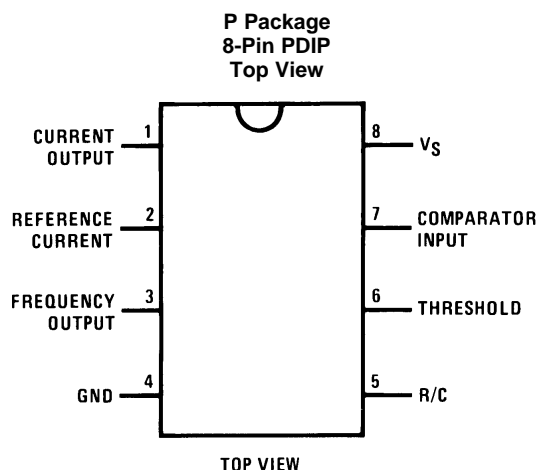

**Pin Functions**

PIN		I/O	DESCRIPTION
NAME	NO.		
IOUT	1	O	Current Output
IREF	2	I	Reference Current
FOUT	3	O	Frequency Output. This output is an open-collector output and requires a pullup resistor.
GND	4	G	Ground
RC	5	I	R-C filter input
THRESH	6	I	Threshold input
COMPIN	7	I	Comparator Input
VS	8	P	Supply Voltage

## 6 Specifications

### 6.1 Absolute Maximum Ratings<sup>(1)(2)(3)</sup>

		MIN	MAX	UNIT
Supply Voltage, $V_S$			40	V
Output Short Circuit to Ground		Continuous		
Output Short Circuit to $V_{CC}$		Continuous		
Input Voltage		-0.2	+ $V_S$	V
Lead Temperature (Soldering, 10 sec.)	PDIP		260	°C

- (1) Stresses beyond those listed under *Absolute Maximum Ratings* may cause permanent damage to the device. These are stress ratings only, which do not imply functional operation of the device at these or any other conditions beyond those indicated under *Recommended Operating Conditions*. Exposure to absolute-maximum-rated conditions for extended periods may affect device reliability.
- (2) All voltages are measured with respect to GND = 0 V, unless otherwise noted.

### 6.2 ESD Ratings

		VALUE	UNIT
$V_{(ESD)}$	Electrostatic discharge	Human body model (HBM), per ANSI/ESDA/JEDEC JS-001 <sup>(1)(2)</sup>	±500 V

- (1) JEDEC document JEP155 states that 500-V HBM allows safe manufacturing with a standard ESD control process.
- (2) Human body model, 100 pF discharged through a 1.5-kΩ resistor.

# XD331 DIP-8 / XL331 SOP8 / XD231 DIP-8

## 6.3 Recommended Operating Conditions

		MIN	MAX	UNIT
Operating Ambient Temperature	XD231	-25	85	°C
	XD331 XL331	0	70	°C
Supply Voltage, $V_S$ <sup>(1)</sup>		4	40	V

(1) All voltages are measured with respect to GND = 0 V, unless otherwise noted.

## 6.4 Thermal Information

THERMAL METRIC <sup>(1)</sup>		XD331 XL331	UNIT
		P (PDIP)	
		8 PINS	
$R_{\theta JA}$	Junction-to-ambient thermal resistance	100	°C/W

(1) For more information about traditional and new thermal metrics, see the *Semiconductor and IC Package Thermal Metrics* application report, SPRA953.

## 6.5 Electrical Characteristics

PARAMETER		TEST CONDITIONS	MIN	TYP	MAX	UNIT
VFC Non-Linearity <sup>(1)</sup>		$4.5\text{ V} \leq V_S \leq 20\text{ V}$		±0.003	±0.01	% Full-Scale
		$T_{MIN} \leq T_A \leq T_{MAX}$		±0.006	±0.02	% Full-Scale
VFC Non-Linearity in Circuit of Figure 14		$V_S = 15\text{ V}$ , $f = 10\text{ Hz to } 11\text{ kHz}$		±0.024	±0.14	% Full-Scale
Conversion Accuracy Scale Factor (Gain)	XD231	$V_{IN} = -10\text{ V}$ , $R_S = 14\text{ k}\Omega$	0.95	1	1.05	kHz/V
	XD331, XL331		0.9	1	1.1	kHz/V
Temperature Stability of Gain	XDx31	$T_{MIN} \leq T_A \leq T_{MAX}$ $4.5\text{ V} \leq V_S \leq 20\text{ V}$		±30	±150	ppm/°C
	XDx31			±20	±50	ppm/°C
Change of Gain with $V_S$		$4.5\text{ V} \leq V_S \leq 10\text{ V}$		0.01	0.1	%/V
		$10\text{ V} \leq V_S \leq 40\text{ V}$		0.006	0.06	%/V
Rated Full-Scale Frequency		$V_{IN} = -10\text{ V}$	10.0			kHz
Gain Stability vs. Time (1000 Hours)		$T_{MIN} \leq T_A \leq T_{MAX}$		±0.02		% Full-Scale
Over Range (Beyond Full-Scale) Frequency		$V_{IN} = -11\text{ V}$	10%			
<b>INPUT COMPARATOR</b>						
Offset Voltage				±3	±10	mV
	XD231	$T_{MIN} \leq T_A \leq T_{MAX}$		±4	±14	mV
	XD331/XL331	$T_{MIN} \leq T_A \leq T_{MAX}$		±3	±10	mV
Bias Current				-80	-300	nA
Offset Current				±8	±100	nA
Common-Mode Range		$T_{MIN} \leq T_A \leq T_{MAX}$	-0.2		$V_{CC} - 2$	V
<b>TIMER</b>						
Timer Threshold Voltage, Pin 5			$0.63 \times V_S$	$0.667 \times V_S$	$0.7 \times V_S$	
Input Bias Current, Pin 5		$V_S = 15\text{ V}$				
	All Devices	$0\text{ V} \leq V_{PIN\ 5} \leq 9.9\text{ V}$		±10	±100	nA
	XD231	$V_{PIN\ 5} = 10\text{ V}$		200	1000	nA
	XD331/XL331	$V_{PIN\ 5} = 10\text{ V}$		200	500	nA
$V_{SAT\ PIN\ 5}$ (Reset)		$I = 5\text{ mA}$		0.22	0.5	V

(1) Non-linearity is defined as the deviation of  $f_{OUT}$  from  $V_{IN} \times (10\text{ kHz}/-10\text{ V}_{DC})$  when the circuit has been trimmed for zero error at 10 Hz and at 10 kHz, over the frequency range 1 Hz to 11 kHz. For the timing capacitor,  $C_T$ , use NPO ceramic, Teflon®, or polystyrene.

# XD331 DIP-8 / XL331 SOP8 / XD231 DIP-8

## Electrical Characteristics (continued)

PARAMETER		TEST CONDITIONS	MIN	TYP	MAX	UNIT
<b>CURRENT SOURCE (PIN 1)</b>						
Output Current	XD231	$R_S = 14\text{ k}\Omega, V_{\text{PIN } 1} = 0$	126	135	144	$\mu\text{A}$
	XD331, XL331		116	136	156	$\mu\text{A}$
Change with Voltage		$0\text{V} \leq V_{\text{PIN } 1} \leq 10\text{ V}$		0.2	1	$\mu\text{A}$
Current Source OFF Leakage	XD231 XD331 XL331			0.02	10	nA
	All Devices	$T_A = T_{\text{MAX}}$		2	50	nA
Operating Range of Current (Typical)			(10 to 500)			$\mu\text{A}$
<b>REFERENCE VOLTAGE (PIN 2)</b>						
XD231			1.76	1.89	2.02	$V_{\text{DC}}$
XD331, XL331			1.7	1.89	2.08	$V_{\text{DC}}$
Stability vs. Temperature				$\pm 60$		ppm/ $^{\circ}\text{C}$
Stability vs. Time, 1000 Hours				$\pm 0.1\%$		
<b>LOGIC OUTPUT (PIN 3)</b>						
$V_{\text{SAT}}$	$I = 5\text{ mA}$			0.15	0.5	V
	$I = 3.2\text{ mA}$ (2 TTL Loads), $T_{\text{MIN}} \leq T_A \leq T_{\text{MAX}}$			0.1	0.4	V
OFF Leakage				$\pm 0.05$	1	$\mu\text{A}$
<b>SUPPLY CURRENT</b>						
XD231	$V_S = 5\text{ V}$		2	3	4	mA
	$V_S = 40\text{ V}$		2.5	4	6	mA
XD331, XL331	$V_S = 5\text{ V}$		1.5	3	6	mA
	$V_S = 40\text{ V}$		2	4	8	mA

## 6.6 Dissipation Ratings

	VALUE	UNIT
Package Dissipation at 25 $^{\circ}\text{C}$ <sup>(1)</sup>	1.25	W

- (1) The absolute maximum junction temperature ( $T_{\text{Jmax}}$ ) for this device is 150 $^{\circ}\text{C}$ . The maximum allowable power dissipation is dictated by  $T_{\text{Jmax}}$ , the junction-to-ambient thermal resistance ( $\theta_{\text{JA}}$ ), and the ambient temperature  $T_A$ , and can be calculated using the formula  $P_{\text{Dmax}} = (T_{\text{Jmax}} - T_A) / \theta_{\text{JA}}$ . The values for maximum power dissipation will be reached only when the device is operated in a severe fault condition (e.g., when input or output pins are driven beyond the power supply voltages, or the power supply polarity is reversed). Obviously, such conditions should always be avoided.

# XD331 DIP-8 / XL331 SOP8 / XD231 DIP-8

## 6.7 Typical Characteristics

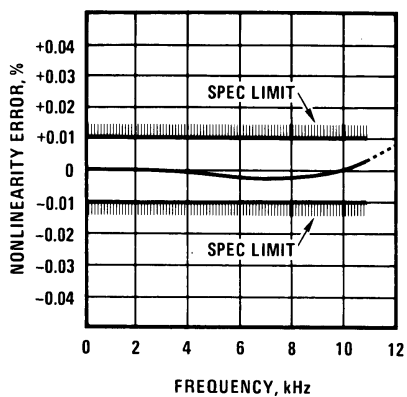

Figure 1. Non-Linearity Error as Precision V-to-F Converter

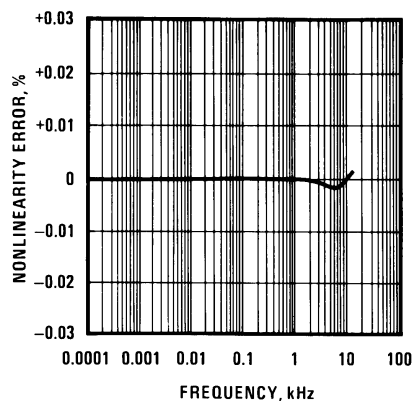

Figure 2. Non-Linearity Error

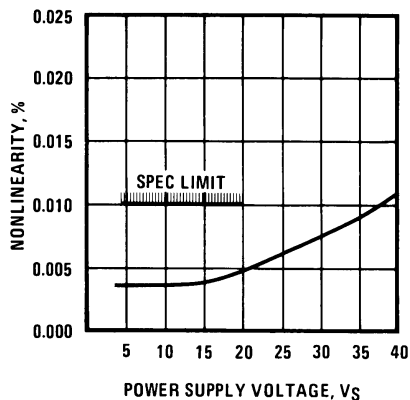

Figure 3. Non-Linearity Error vs. Power Supply Voltage

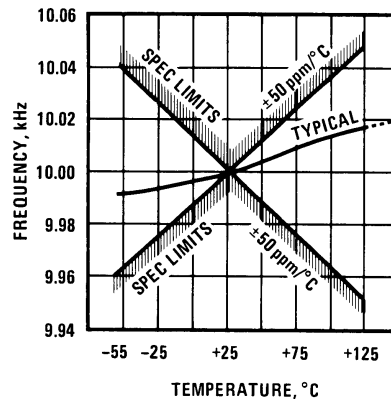

Figure 4. Frequency vs. Temperature

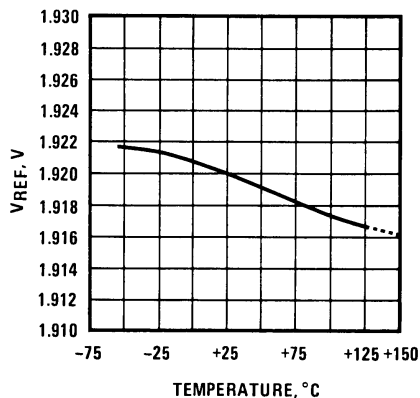

Figure 5.  $V_{REF}$  vs. Temperature

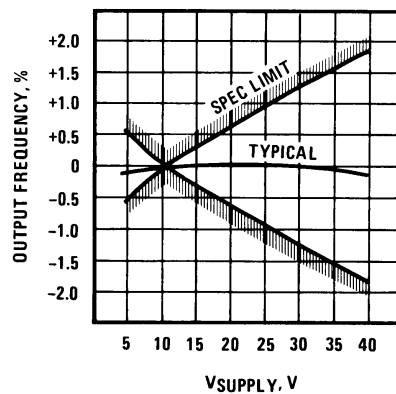

Figure 6. Output Frequency vs.  $V_{SUPPLY}$

# XD331 DIP-8 / XL331 SOP8 / XD231 DIP-8

## Typical Characteristics (continued)

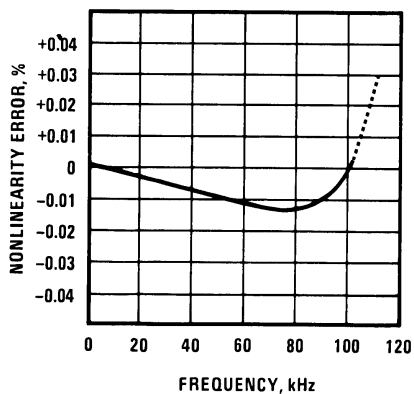

Figure 7. 100 kHz Non-Linearity Error

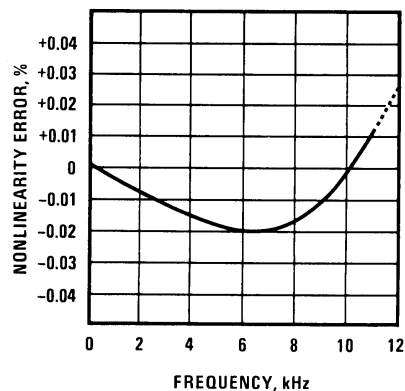

Figure 8. Non-Linearity Error (Figure 14)

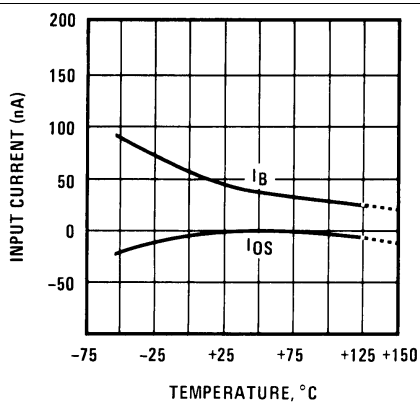

Figure 9. Input Current (Pins 6,7) vs. Temperature

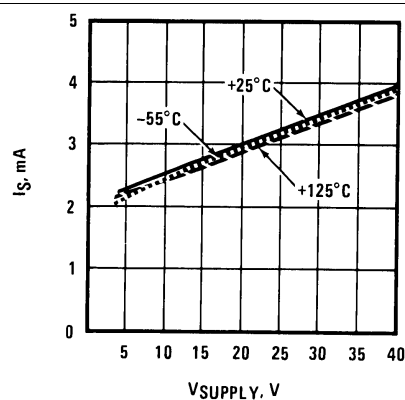

Figure 10. Power Drain vs.  $V_{SUPPLY}$

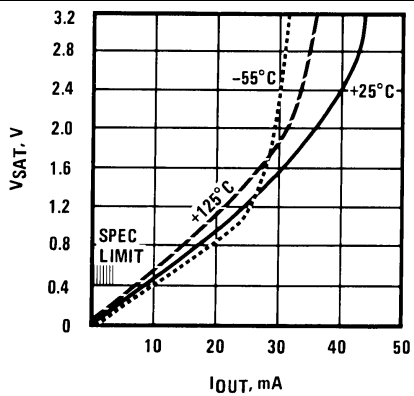

Figure 11. Output Saturation Voltage vs.  $I_{OUT}$  (Pin 3)

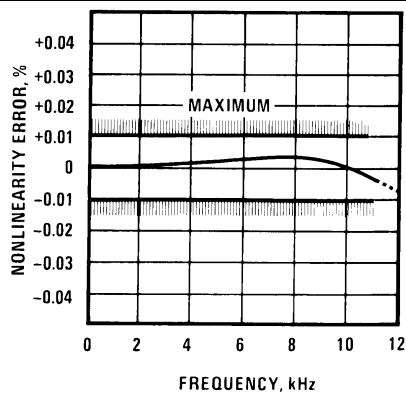

Figure 12. Non-Linearity Error, Precision F-to-V Converter

# XD331 DIP-8 / XL331 SOP8 / XD231 DIP-8

## 7 Detailed Description

### 7.1 Overview

#### 7.1.1 Detail of Operation, Functional Block Diagram

The *Functional Block Diagram* shows a band gap reference which provides a stable 1.9-V<sub>DC</sub> output. This 1.9 V<sub>DC</sub> is well regulated over a V<sub>S</sub> range of 3.9 V to 40 V. It also has a flat, low temperature coefficient, and typically changes less than ½% over a 100°C temperature change.

The current pump circuit forces the voltage at pin 2 to be at 1.9 V, and causes a current  $i = 1.90 \text{ V}/R_S$  to flow. For  $R_S=14 \text{ k}$ ,  $i=135 \mu\text{A}$ . The precision current reflector provides a current equal to  $i$  to the current switch. The current switch switches the current to pin 1 or to ground, depending upon the state of the R-S flip-flop.

The timing function consists of an R-S flip-flop and a timer comparator connected to the external R<sub>t</sub>C<sub>t</sub> network. When the input comparator detects a voltage at pin 7 higher than pin 6, it sets the R-S flip-flop which turns ON the current switch and the output driver transistor. When the voltage at pin 5 rises to ⅔ V<sub>CC</sub>, the timer comparator causes the R-S flip-flop to reset. The reset transistor is then turned ON and the current switch is turned OFF.

However, if the input comparator still detects the voltage on pin 7 as higher than pin 6 when pin 5 crosses ⅔ V<sub>CC</sub>, the flip-flop will not be reset, and the current at pin 1 will continue to flow, trying to make the voltage at pin 6 higher than pin 7. This condition will usually apply under start-up conditions or in the case of an overload voltage at signal input. During this sort of overload the output frequency will be 0. As soon as the signal is restored to the working range, the output frequency will be resumed.

#### 7.2 Functional Block Diagram

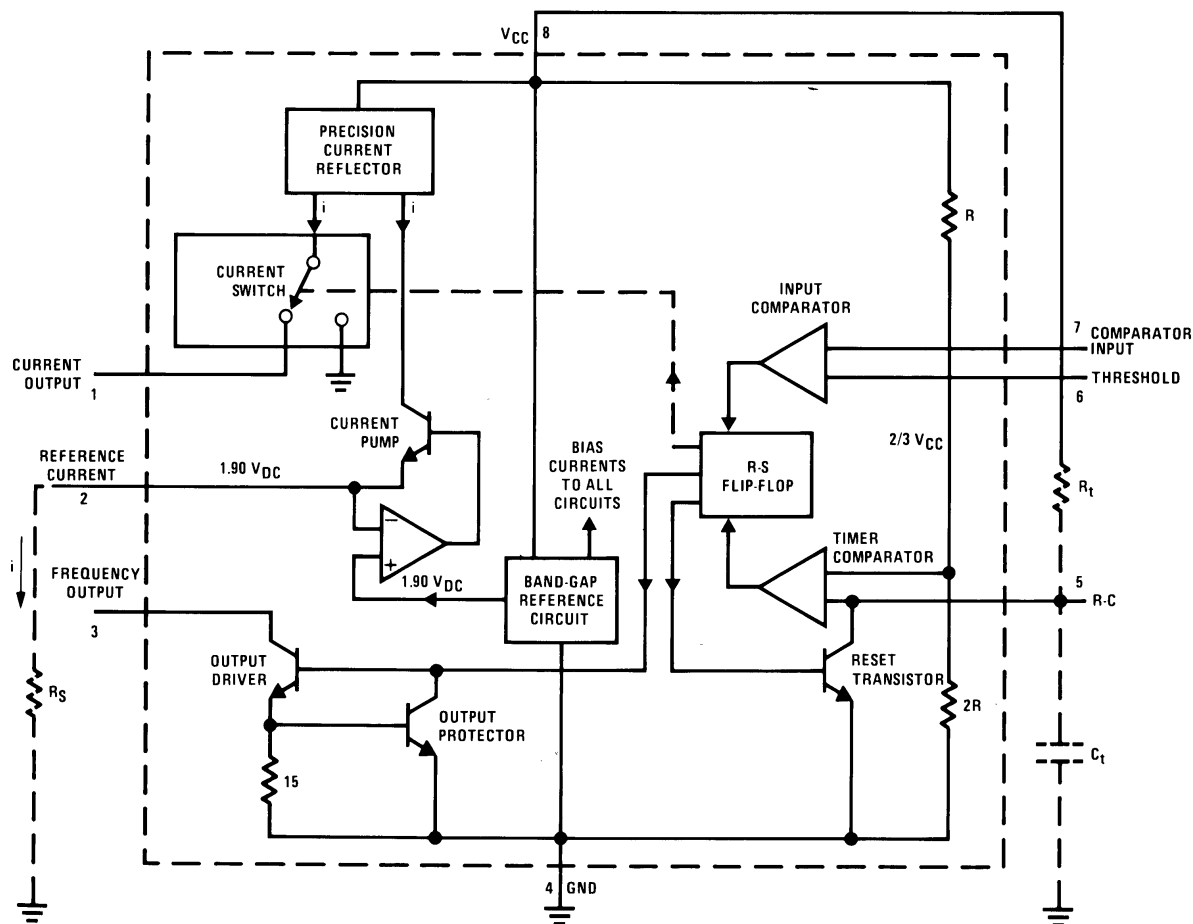

## 8 Application and Implementation

### 8.1 Application Information

#### 8.1.1 Simplified Voltage-to-Frequency Converter

The operation of these blocks is best understood by going through the operating cycle of the basic V-to-F converter, Figure 13, which consists of the simplified block diagram of the XDx31 and the various resistors and capacitors connected to it.

The voltage comparator compares a positive input voltage,  $V_1$ , at pin 7 to the voltage,  $V_x$ , at pin 6. If  $V_1$  is greater, the comparator will trigger the 1-shot timer. The output of the timer will turn ON both the frequency output transistor and the switched current source for a period  $t = 1.1 R_t C_t$ . During this period, the current  $i$  will flow out of the switched current source and provide a fixed amount of charge,  $Q = i \times t$ , into the capacitor,  $C_L$ . This will normally charge  $V_x$  up to a higher level than  $V_1$ . At the end of the timing period, the current  $i$  will turn OFF, and the timer will reset itself.

Now there is no current flowing from pin 1, and the capacitor  $C_L$  will be gradually discharged by  $R_L$  until  $V_x$  falls to the level of  $V_1$ . Then the comparator will trigger the timer and start another cycle.

The current flowing into  $C_L$  is exactly  $I_{AVE} = i \times (1.1 \times R_t C_t) \times f$ , and the current flowing out of  $C_L$  is exactly  $V_x / R_L \approx V_{IN} / R_L$ . If  $V_{IN}$  is doubled, the frequency will double to maintain this balance. Even a simple V-to-F converter can provide a frequency precisely proportional to its input voltage over a wide range of frequencies.

#### 9.1.2 Principles of Operation

The XDx31 are monolithic circuits designed for accuracy and versatile operation when applied as voltage-to-frequency (V-to-F) converters or as frequency-to-voltage (F-to-V) converters. A simplified block diagram of the XDx31 is shown in Figure 13 and consists of a switched current source, input comparator, and 1-shot timer.

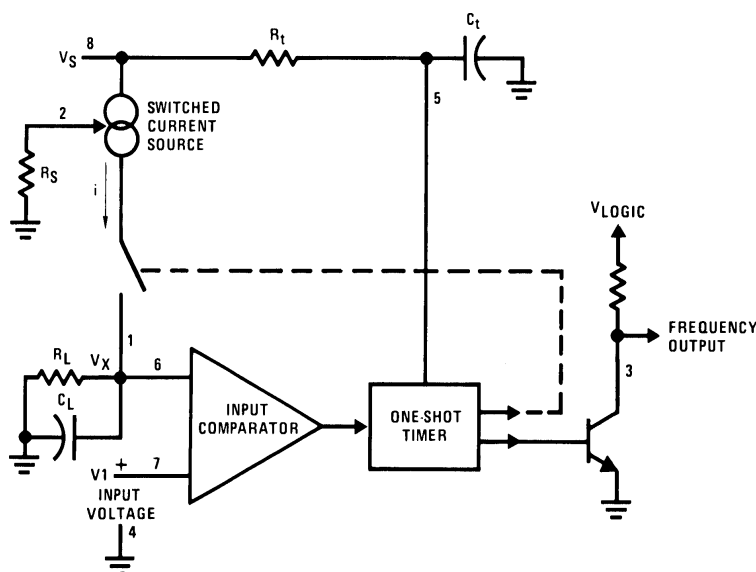

**Figure 13. Simplified Block Diagram of Stand-Alone Voltage-to-Frequency Converter and External Components**



## 8.2 Typical Applications

### 8.2.1 Basic Voltage-to-Frequency Converter

The simple stand-alone V-to-F converter shown in Figure 14 includes all the basic circuitry of Figure 13 plus a few components for improved performance.

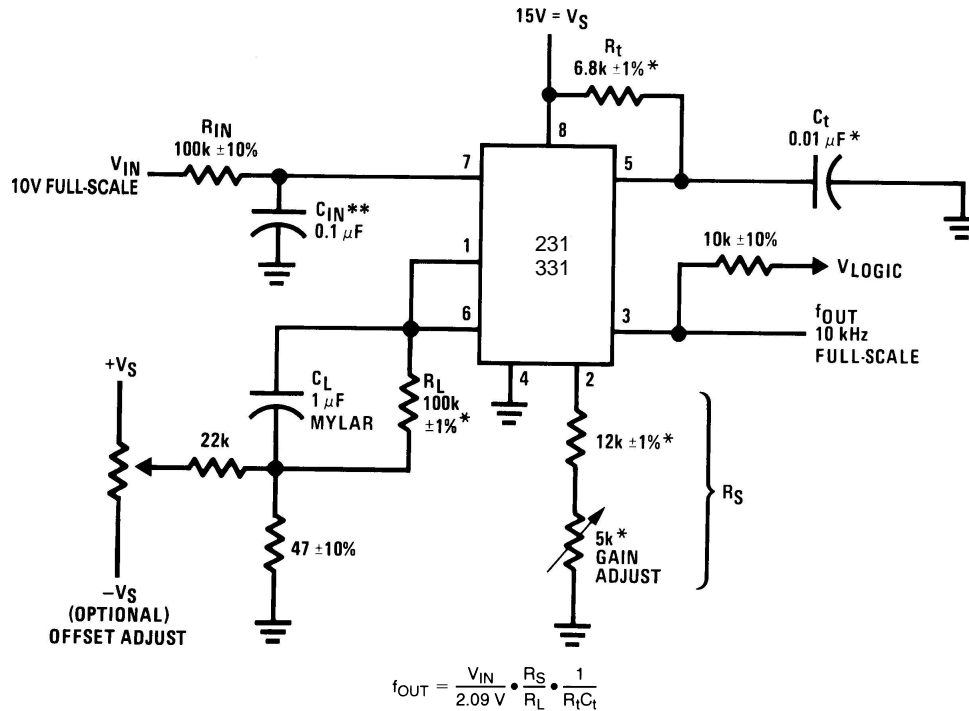

\*Use stable components with low temperature coefficients. See *Application Information*.

\*\*0.1 μF or 1 μF, See *Typical Applications*.

**Figure 14. Simple Stand-Alone V-to-F Converter with ±0.03% Typical Linearity (f = 10 Hz to 11 kHz)**

#### 8.2.1.1 Design Requirements

For this example, the system requirements are 0.05% linearity over an output frequency range of 10 Hz to 4 kHz with an input voltage range of 25 mV to 12.5 V. The available supply voltage is 15.0 V.

#### 8.2.1.2 Detailed Design Procedure

A capacitor  $C_{IN}$  is added from pin 7 to ground to act as a filter for  $V_{IN}$ , use of a 0.1 μF is appropriate for this application. A value of 0.01 μF to 0.1 μF will be adequate in most cases; however, in cases where better filtering is required, a 1-μF capacitor can be used. When the RC time constants are matched at pin 6 and pin 7, a voltage step at  $V_{IN}$  will cause a step change in  $f_{OUT}$ . If  $C_{IN}$  is much less than  $C_L$ , a step at  $V_{IN}$  may cause  $f_{OUT}$  to stop momentarily.

Next, we cancel the comparator bias current by setting  $R_{IN}$  to 100 kΩ to match  $R_L$ . This will help to minimize any frequency offset.

For best results, all the components should be stable low-temperature-coefficient components, such as metal-film resistors. The capacitor should have low dielectric absorption; depending on the temperature characteristics desired, NPO ceramic, polystyrene, Teflon or polypropylene are best suited.

The resistance  $R_S$  at pin 2 is made up of a 12-kΩ fixed resistor plus a 5-kΩ (cermet, preferably) gain adjust rheostat. The function of this adjustment is to trim out the gain tolerance of the XDx31, and the tolerance of  $R_T$ ,  $R_L$  and  $C_T$ .

## X-ON Electronics

Largest Supplier of Electrical and Electronic Components

*Click to view similar products for [Analog to Digital Converters - ADC category](#):*

*Click to view products by [XINLUDA manufacturer](#):*

Other Similar products are found below :

[017539FB](#) [020296DB](#) [ADC0820CNEN](#) [AD7916BRMZ-RL7](#) [AD9257TCPZ-65-EP](#) [ADC0804LCD](#) [ADC0808](#) [MCP37211-200I/TE](#)  
[512761G](#) [AD9695BCPZ-625](#) [AD9695BCPZ-1300](#) [MX574AKEQI](#) [MAX15511TGTL+](#) [MAX11156ETC+T](#) [MAX1111EEE/V+](#) [AD7175-](#)  
[8BCPZ-RL7](#) [AD9530BCPZ](#) [MAX1436BECQ+D](#) [MAX16924GGM/VY+](#) [MAX11108AVB+T](#) [MAX11647EUA+T](#) [MCP33141-10T-E/MS](#)  
[MCP33141D-05T-E/MS](#) [MCP33151D-05T-E/MS](#) [MCP3202T-CI/MS](#) [MAX11137ATI+T](#) [MAX11136ATI+T](#) [MAX11612EUA+T](#)  
[MAX11212AEUB+T](#) [MAX11101EUB+T](#) [AD4001BCPZ-RL7](#) [MAX14002AAP+T](#) [MCP33141-05T-E/MS](#) [MAX11636EEE+T](#) [MCP33141D-](#)  
[10T-E/MS](#) [MCP33151-05T-E/MS](#) [MCP33151-10T-E/MS](#) [MCP33151D-10T-E/MS](#) [MAX11259AWX+T](#) [AD7091R-5BRUZ-RL7](#)  
[ADE1201ACCZ](#) [ADE1202ACCZ](#) [LTC1864CS8#PBF](#) [LTC2418CGNPBF](#) [LTC2433-1IMS#PBF](#) [LTC2442CGPBF](#) [LTC2400CS8#PBF](#)  
[LTC2414CGNPBF](#) [TC7109ACKW](#) [TC7109CLW](#)