

XD2917-8/XD2907-8/XD2907-14/XD2917-14 DIP XL2907-8/XL2917-8/XL2907-14/XL2917-14 SOP

1 Features

- Ground Referenced Tachometer Input Interfaces Directly With Variable Reluctance Magnetic Pickups
- Op Amp Has Floating Transistor Output
- 50-mA Sink or Source to Operate Relays, Solenoids, Meters, or LEDs
- Frequency Doubling For Low Ripple
- Tachometer Has Built-In Hysteresis With Either Differential Input or Ground Referenced Input
- $\pm 0.3\%$ Linearity (Typical)
- Ground-Referenced Tachometer is Fully Protected From Damage Due to Swings Above V_{CC} and Below Ground
- Output Swings to Ground For Zero Frequency Input
- Easy to Use; $V_{OUT} = f_{IN} \times V_{CC} \times R1 \times C1$
- Zener Regulator on Chip allows Accurate and Stable Frequency to Voltage or Current Conversion (XD2917)

2 Applications

- Over- and Under-Speed Sensing
- Frequency-to-Voltage Conversion (Tachometer)
- Speedometers
- Breaker Point Dwell Meters
- Hand-Held Tachometers
- Speed Governors
- Cruise Control
- Automotive Door Lock Control
- Clutch Control
- Horn Control
- Touch or Sound Switches

3 Description

The XD2907 and XD2917 devices are monolithic frequency-to-voltage converters with a high gain op amp designed to operate a relay, lamp, or other load when the input frequency reaches or exceeds a selected rate. The tachometer uses a charge pump technique and offers frequency doubling for low-ripple, full-input protection in two versions (8-pin XD2907 and XD2917), and its output swings to ground for a zero frequency input.

The op amp is fully compatible with the tachometer and has a floating transistor as its output. This feature allows either a ground or supply referred load of up to 50 mA. The collector may be taken above V_{CC} up to a maximum V_{CE} of 28 V.

The two basic configurations offered include an 8-pin device with a *ground-referenced tachometer* input and an internal connection between the tachometer output and the op amp noninverting input. This version is well suited for single speed or frequency switching or fully buffered frequency-to-voltage conversion applications.

4 Device Information⁽¹⁾

PART NUMBER	PACKAGE	BODY SIZE (NOM)
2917 2907	PDIP (8)	6.35 mm x 9.81 mm
	PDIP (14)	6.35 mm x 19.177 mm
	SOIC (8)	3.91 mm x 4.90 mm
	SOIC (14)	3.91 mm x 8.65 mm

(1) For all available packages, see the orderable addendum at the end of the data sheet.

Minimum Component Tachometer Diagram

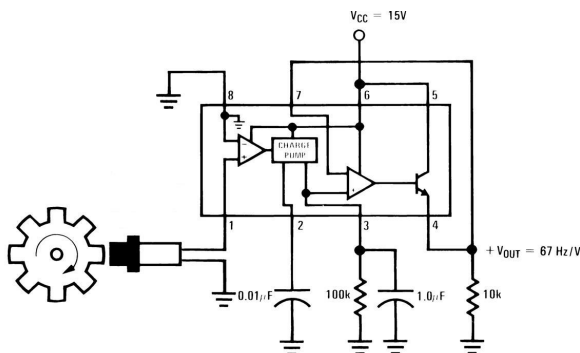

XD2917-8/XD2907-8/XD2907-14/XD2917-14 DIP
 XL2907-8/XL2917-8/XL2907-14/XL2917-14 SOP

5 Description (continued)

The more versatile configurations provide differential tachometer input and uncommitted op amp inputs. With this version the tachometer input may be floated and the op amp becomes suitable for active filter conditioning of the tachometer output.

Both of these configurations are available with an active shunt regulator connected across the power leads. The regulator clamps the supply such that stable frequency-to-voltage and frequency-to-current operations are possible with any supply voltage and a suitable resistor.

6 Pin Configuration and Functions

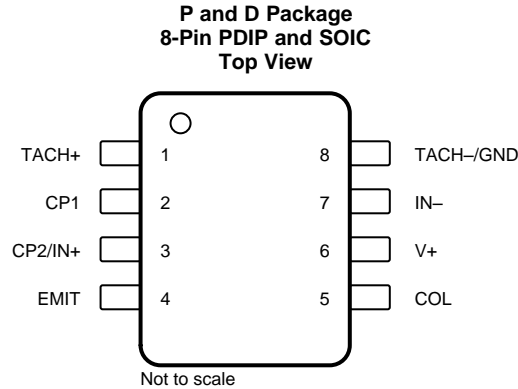

Pin Functions: 8 Pins

PIN		I/O	DESCRIPTION
NAME	NO.		
COL	5	I	The collector of the bipolar junction transistor
CP1	2	O	A capacitor placed on this pin will be charged up to $V_{CC}/2$ by a constant current source of $180 \mu\text{A}$ typical at the start of every positive half cycle. At the beginning of negative half cycles this capacitor is discharged the same amount at the same rate.
CP2/IN+	3	I/O	See pins CP1 and IN+. On 8-pin devices (8-pin XD2907 and XD2917) these two nodes share a pin and are internally connected.
EMIT	4	O	The emitter of the bipolar junction transistor
GND	—	G	Ground
IN+	—	I	The noninverting input to the high gain op amp
IN-	7	I	The inverting input to the high gain op amp
NC	—	—	No connect
TACH+	1	I	Positive terminal for the input signal that leads to the noninverting terminal of the internal Schmitt-Trigger comparator.
TACH-/GND	8	I	Negative terminal for the input signal that leads to the noninverting terminal of the internal Schmitt-Trigger comparator. (NOTE: On 8-pin devices, XD2907 and XD2917, this pin is internally connected to ground and must be tied to ground externally to provide the reference voltage of the device).
V+	6	I	Supply voltage

XD2917-8/XD2907-8/XD2907-14/XD2917-14 DIP
 XL2907-8/XL2917-8/XL2907-14/XL2917-14 SOP

**NFF and D Package
 14-Pin PDIP and SOIC
 Top View**

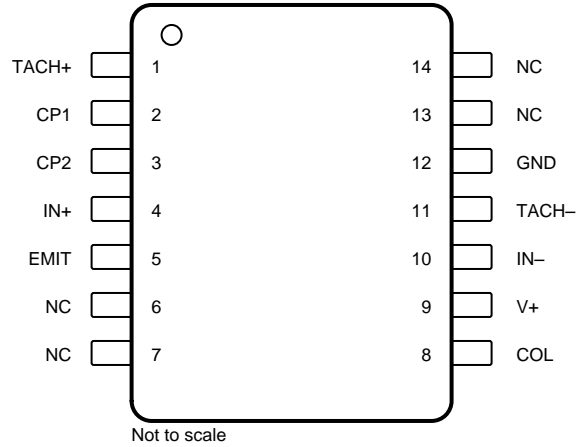

Pin Functions: 14 Pins

PIN		I/O	DESCRIPTION
NAME	NO.		
COL	8	I	The collector of the bipolar junction transistor
CP1	2	O	A capacitor placed on this pin will be charged up to $V_{CC}/2$ by a constant current source of $180 \mu\text{A}$ typical at the start of every positive half cycle. At the beginning of negative half cycles this capacitor is discharged the same amount at the same rate.
CP2	3	O	The charge pump sources current out of this pin equal to the absolute value of the capacitor current on CP1. A resistor and capacitor in parallel connected to this pin filters the current pulses into the output voltage.
EMIT	5	O	The emitter of the bipolar junction transistor
GND	12	G	Ground
IN+	4	I	The noninverting input to the high gain op amp
IN-	10	I	The inverting input to the high gain op amp
NC	6, 7, 13, 14	—	No connect
TACH+	1	I	Positive terminal for the input signal that leads to the noninverting terminal of the internal Schmitt-Trigger comparator.
TACH-	11	I	Negative terminal for the input signal that leads to the noninverting terminal of the internal Schmitt-Trigger comparator.
V+	9	I	Supply voltage

XD2917-8/XD2907-8/XD2907-14/XD2917-14 DIP
 XL2907-8/XL2917-8/XL2907-14/XL2917-14 SOP

7 Specifications

7.1 Absolute Maximum Ratings

over operating free-air temperature range (unless otherwise noted)⁽¹⁾⁽²⁾

			MIN	MAX	UNIT
Supply voltage				28	V
Supply current (Zener options)				25	mA
Collector voltage				28	V
Differential input voltage		Tachometer, op amp, and comparator		28	V
Input voltage	Tachometer	XD2907 (8), XD2917 (8)	-28	28	V
		XD2907 (14), XD2917 (14)	0	28	
	Op amp and comparator		0	28	
Power dissipation	XD29x7 (8)			1200	mW
	XD29x7 (14)			1580	
Soldering information	PDIP package	Soldering (10 s)		260	°C
	SOIC package	Vapor phase (60 s)		215	
		Infrared (15 s)		220	
Operating temperature, T _J			-40	85	°C
Storage temperature, T _{stg}			-65	150	°C

- (1) Stresses beyond those listed under *Absolute Maximum Ratings* may cause permanent damage to the device. These are stress ratings only, which do not imply functional operation of the device at these or any other conditions beyond those indicated under *Recommended Operating Conditions*. Exposure to absolute-maximum-rated conditions for extended periods may affect device reliability.

7.2 ESD Ratings

			VALUE	UNIT
V _(ESD)	Electrostatic discharge	Human-body model (HBM), per ANSI/ESDA/JESD22-A114 ⁽¹⁾	±1000	V
		Charged-device model (CDM), per JEDEC specification JESD22-C101 ⁽²⁾	±250	

- (1) JEDEC document JEP155 states that 500-V HBM allows safe manufacturing with a standard ESD control process.
 (2) JEDEC document JEP157 states that 250-V CDM allows safe manufacturing with a standard ESD control process.

7.3 Recommended Operating Conditions

over operating free-air temperature range (unless otherwise noted)

			MIN	NOM	MAX	UNIT
Input voltage	XD2907 (8), XD2917 (8)		-28		28	V
	XD2907 (14), XD2917 (14)		0		28	V
Output sink current					50	mA

XD2917-8/XD2907-8/XD2907-14/XD2917-14 DIP
 XL2907-8/XL2917-8/XL2907-14/XL2917-14 SOP

7.4 Thermal Information

THERMAL METRIC ⁽¹⁾		XD2907, XD2917				UNIT
		P (PDIP)	D (SOIC)	NFF (PDIP)	D (SOIC)	
		8 PINS	8 PINS	14 PINS	14 PINS	
R _{θJA}	Junction-to-ambient thermal resistance	77.6	110	69.1	83.7	°C/W
R _{θJC(top)}	Junction-to-case (top) thermal resistance	80.5	53.9	64.8	42.1	°C/W
R _{θJB}	Junction-to-board thermal resistance	54.8	50.4	49.1	38	°C/W
ψ _{JT}	Junction-to-top characterization parameter	37.6	9.1	35.1	7.7	°C/W
ψ _{JB}	Junction-to-board characterization parameter	54.8	49.9	49	37.7	°C/W
R _{θJC(bot)}	Junction-to-case (bottom) thermal resistance	—	—	—	—	°C/W

(1) For more information about traditional and new thermal metrics, see the *Semiconductor and IC Package Thermal Metrics* application report.

7.5 Electrical Characteristics

V_{CC} = 12 V_{DC}, T_A = 25°C, see test circuit

PARAMETER	TEST CONDITIONS	MIN	TYP	MAX	UNIT
TACHOMETER					
Input thresholds	V _{IN} = 250 mVp-p at 1 kHz ⁽¹⁾	±10	±25	±40	mV
Hysteresis	V _{IN} = 250 mVp-p at 1 kHz ⁽¹⁾		30		mV
XD29x7 offset voltage	V _{IN} = 250 mVp-p at 1 kHz ⁽¹⁾		3.5	10	mV
	V _{IN} = 250 mVp-p at 1 kHz (8-pin XD29x7) ⁽¹⁾		5	15	
Input bias current	V _{IN} = ±50 mV _{DC}		0.1	1	μA
V _{OH}	High level output voltage For CP1, V _{IN} = 125 mV _{DC} ⁽²⁾		8.3		V
V _{OL}	Low level output voltage For CP1, V _{IN} = -125 mV _{DC} ⁽²⁾		2.3		V
I ₂ , I ₃	Output current V ₂ = V ₃ = 6 V ⁽³⁾	140	180	240	μA
I ₃	Leakage current I ₂ = 0, V ₃ = 0			0.1	μA
K	Gain constant See ⁽²⁾	0.9	1	1.1	
Linearity	f _{IN} = 1 kHz, 5 kHz, or 10 kHz ⁽⁴⁾	-1%	0.3%	1%	
OP AMP AND COMPARATOR					
V _{OS}	Input offset voltage V _{IN} = 6 V		3	10	mV
I _{BIAS}	Bias current V _{IN} = 6 V		50	500	nA
Input common-mode voltage		0		V _{CC} -1.5	V
Voltage gain			200		V/mV
Output sink current	V _C = 1	40	50		mA
Output source current	V _E = V _{CC} - 2		10		mA
Saturation voltage	I _{SINK} = 5 mA		0.1	0.5	V
	I _{SINK} = 20 mA			1	V
	I _{SINK} = 50 mA		1	1.5	V
ZENER REGULATOR					
Regulator voltage	R _{DROP} = 470 Ω		7.56		V
Series resistance			10.5	15	Ω
Temperature stability			1		mV/°C
Total supply current			3.8	6	mA

- (1) Hysteresis is the sum V_{TH} - (-V_{TH}), offset voltage is their difference. See test circuit.
- (2) V_{OH} = 0.75 × V_{CC} - 1 V_{BE} and V_{OL} = 0.25 × V_{CC} - 1 V_{BE}, therefore V_{OH} - V_{OL} = V_{CC} / 2. The difference (V_{OH} - V_{OL}) and the mirror gain (I₂ / I₃) are the two factors that cause the tachometer gain constant to vary from 1.
- (3) Ensure that when choosing the time constant R1 × C1 that the maximum anticipated output voltage at CP2/IN+ can be reached with I₃ × R1. The maximum value for R1 is limited by the output resistance of CP2/IN+ which is greater than 10 MΩ typically.
- (4) Nonlinearity is defined as the deviation of V_{OUT} (at CP2/IN+) for f_{IN} = 5 kHz from a straight line defined by the V_{OUT} at 1 kHz and V_{OUT} at 10 kHz. C1 = 1000 pF, R1 = 68 kΩ and C2 = 0.22 μF.

7.6 Typical Characteristics

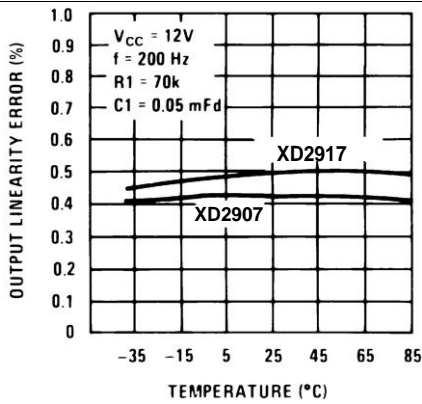

Figure 1. Tachometer Linearity vs Temperature

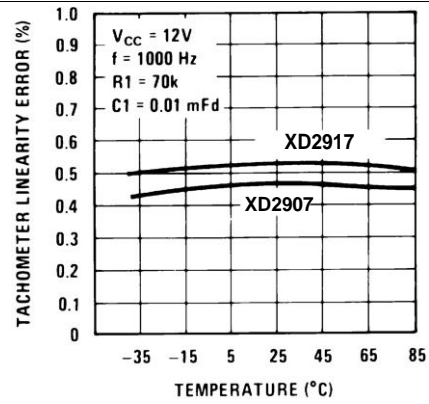

Figure 2. Tachometer Linearity vs Temperature

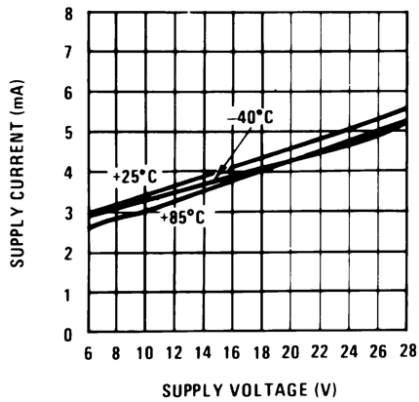

Figure 3. Total Supply Current

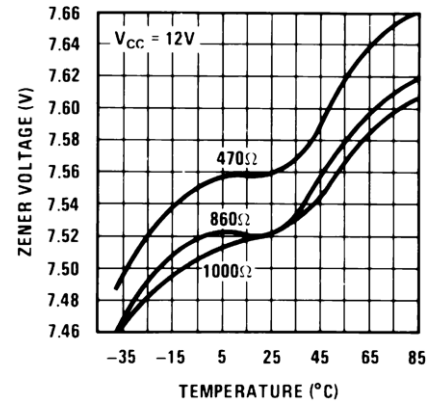

Figure 4. Zener Voltage vs Temperature

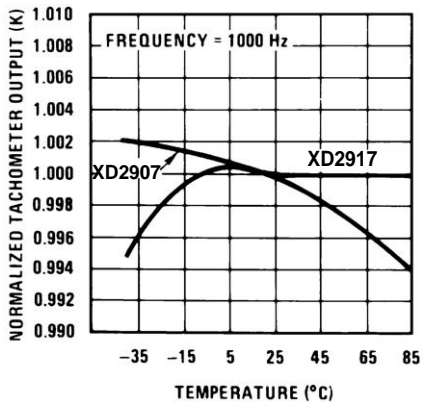

Figure 5. Normalized Tachometer Output (K) vs Temperature

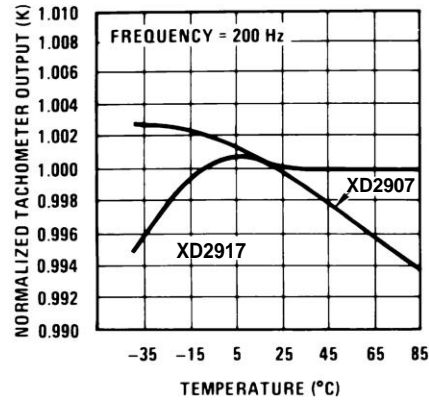

Figure 6. Normalized Tachometer Output (K) vs Temperature

Typical Characteristics (continued)

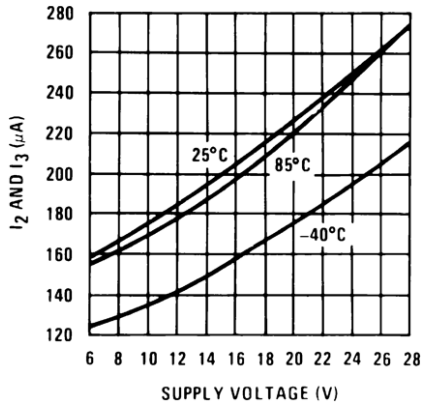

Figure 7. Tachometer Currents I_2 and I_3 vs Supply Voltage

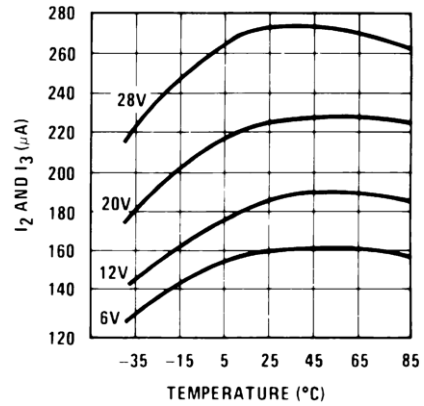

Figure 8. Tachometer Currents I_2 and I_3 vs Temperature

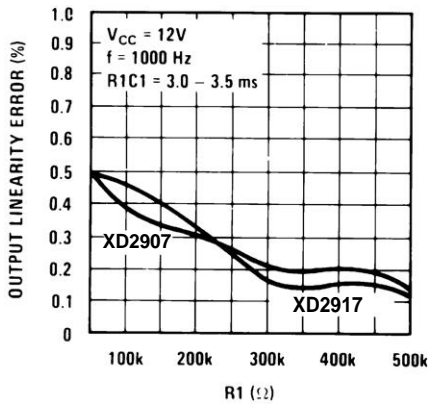

Figure 9. Tachometer Linearity vs R_1

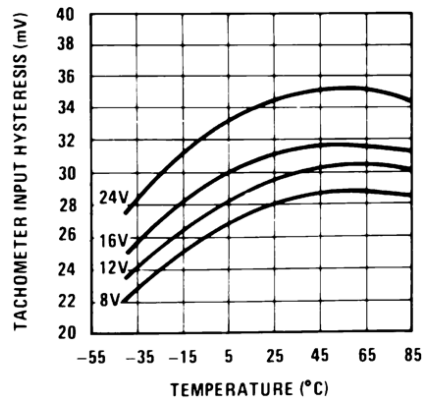

Figure 10. Tachometer Input Hysteresis vs Temperature

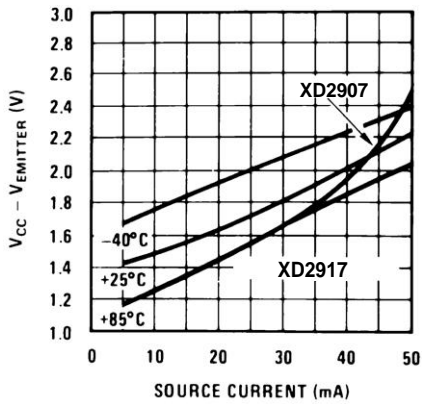

Figure 11. Op Amp Output Transistor Characteristics

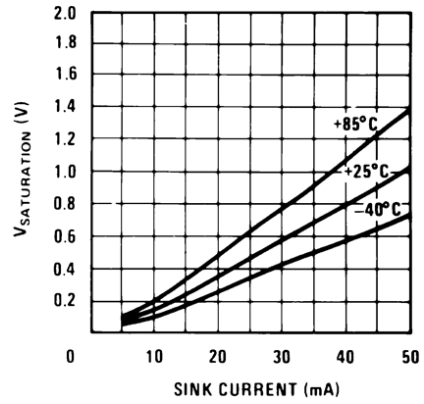

Figure 12. Op Amp Output Transistor Characteristics

8 Parameter Measurement Information

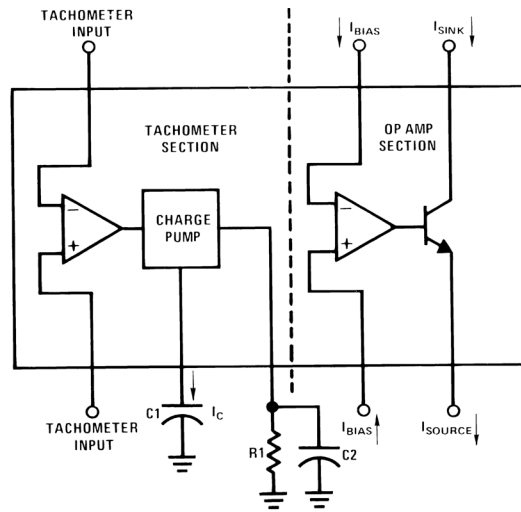

Figure 13. Test Circuit

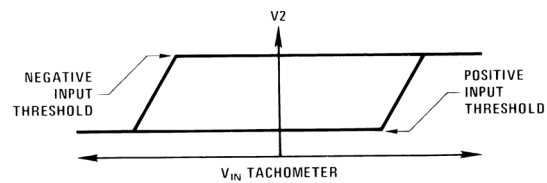

Figure 14. Tachometer Input Threshold Measurement

9 Detailed Description

9.1 Overview

The XD29x7 frequency-to-voltage converter features two separate inputs to monitor the signal. In the 8-pin devices, one of these inputs is internally grounded and therefore it monitors the remaining input for zero crossings. In the 14-pin devices, both of these inputs are open and it instead detects whenever the differential voltage switches polarity. Therefore, the input comparator outputs a square wave of equal frequency to the input.

A charge pump system is used to translate the frequency of this square wave to a voltage. At the start of every positive half cycle of the input signal a 180- μ A constant current charges C1 until its voltage has increased by $V_{CC}/2$. The capacitor is held at that voltage until the input signal begins a negative half cycle. Then the 180- μ A constant current discharges capacitor C1 until its voltage has dropped by $V_{CC}/2$. This voltage is held until the next positive half cycle and the process repeats. This generates pulses of current flowing into and out of capacitor C1 at the same frequency as the input signal. For every full cycle, the charge pump mirrors both current pulses as positive current pulses into the parallel combination of resistor R1 and capacitor C2. Therefore every full cycle, the amount of charge leaving pin 3 is equal to the sum of the charge entering C1 and leaving C1. Because the voltage at pin 3 is equal to $I3(\text{avg}) \times R1$, $I(\text{avg})$ is calculated in Equation 1.

$$I3(\text{avg}) = Q/t = (Q_{\text{charge}} + Q_{\text{discharge}}) / (1/f) = 2 \times Q \times f = 2 \times C1 \times (V_{CC}/2) \times f = C1 \times V_{CC} \times f \quad (1)$$

This average current will be flowing across R1, giving the output voltage in Equation 2.

$$V_o = R1 \times C1 \times V_{CC} \times f \quad (2)$$

C2 acts as a filter to smooth the pulses of current and does not affect the output voltage. However, the size of C2 determines both the output response time for changes in frequency and the amount of output voltage ripple.

The voltage generated is then fed in a high gain op amp. This op amp drives a bipolar transistor whose collector and emitter are each broken out to a pin. The XD29x7 has the flexibility to be configured a variety of ways to meet system requirements including voltage output, driving loads, operating a relay, and more.

9.2 Functional Block Diagram

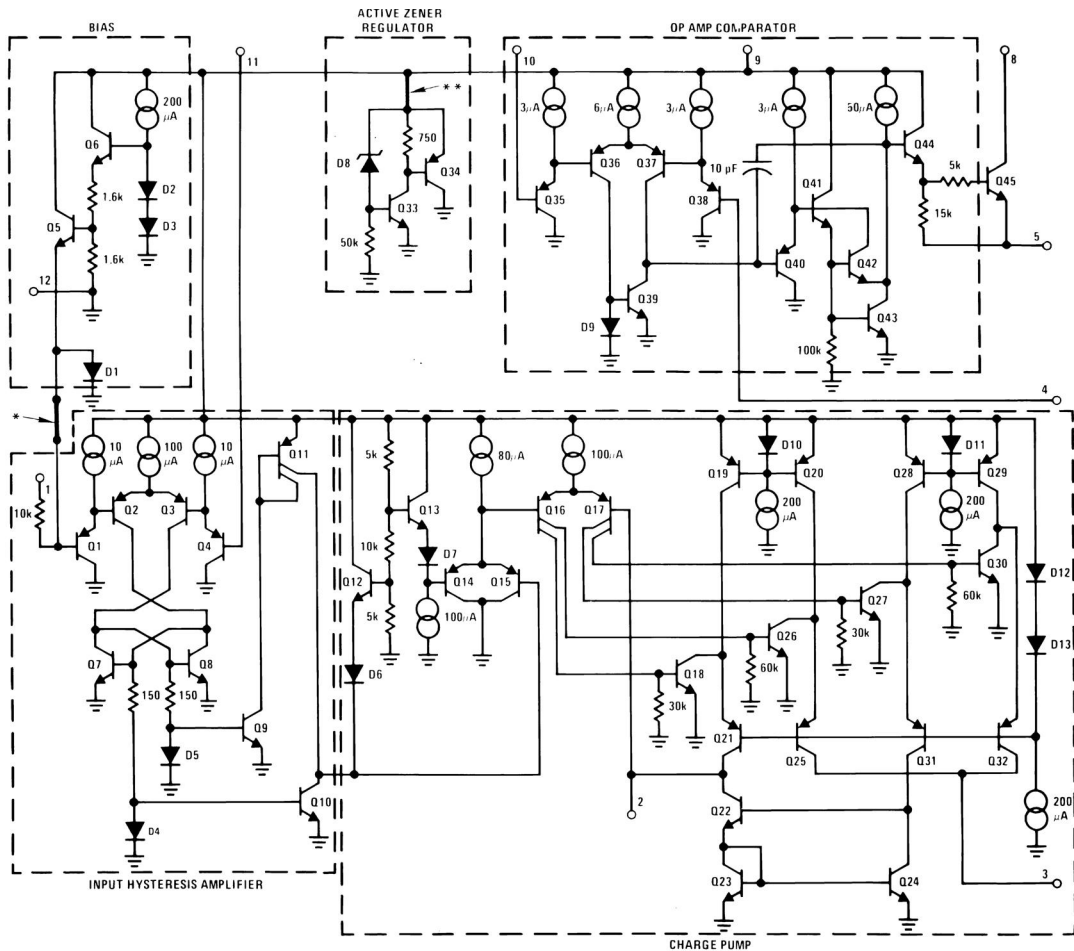

9.3 Feature Description

9.3.1 Differential Input

This device features a Schmitt-Trigger comparator that is the first stage in converting the input signal. Every time the output of the comparator flips between high and low correlates to a half cycle elapsing on the input signal. On the XD29x7-8 devices, one terminal of this comparator is internally connected to ground. This requires that the input signal cross zero volts in order for device to detect the frequency. On the XD29x7 devices, the input terminals to the Schmitt-Trigger comparator are both available for use. This open terminal allows the potential at which the comparator's output is flipped to be applied externally. This allows the device to accept signals with DC offset or compare differential inputs.

9.3.2 Configurable

While the ratio of output voltage to input frequency is dependent on supply voltage, it is easily adjusted through the combination of one resistor and one capacitor, R1 and C1. The formula for calculating the expected output voltage is in Equation 3.

$$V_{OUT} = V_{CC} \times f \times C1 \times R1. \tag{3}$$

The sizes of R1 and C1 have other effects on the system such as maximum frequency and output linearity. See *Choosing R1 and C1* for detailed instructions on sizing components.

Feature Description (continued)

9.3.3 Output Stage

The output voltage generated by the charge pump is fed in the noninverting terminal of a high gain op amp. This op amp then drives an uncommitted bipolar junction transistor. This allows the XD2907 to be configured a variety of ways to meet system needs. The output voltage can be buffered and used to drive a load (see Figure 15) or an output threshold can be given to trigger a load switch (see Figure 18).

9.4 Device Functional Modes

9.4.1 Grounded Input Devices (8-Pin XD2907 and XD2917)

These devices have one of the two Schmitt-Trigger comparator inputs internally grounded and must be externally connected to the system ground as well. This configuration monitors the remaining terminal for zero crossings.

9.4.2 Differential Input Devices XD2907 and XD2917

These devices have both inputs to the Schmitt-Trigger comparator available and broken out to pins 1 and 11. This configuration allows a new switching threshold provided in the case of signals with DC offset or to intake a differential pair and switch based on voltage difference.

X-ON Electronics

Largest Supplier of Electrical and Electronic Components

Click to view similar products for [Analog to Digital Converters - ADC category](#):

Click to view products by [XINLUDA manufacturer](#):

Other Similar products are found below :

[017539FB](#) [020296DB](#) [ADC0820CNEN](#) [AD7916BRMZ-RL7](#) [AD9257TCPZ-65-EP](#) [ADC0804LCD](#) [ADC0808](#) [MCP37211-200I/TE](#)
[512761G](#) [AD9695BCPZ-625](#) [AD9695BCPZ-1300](#) [MX574AKEQI](#) [MAX15511TGTL+](#) [MAX11156ETC+T](#) [MAX1111EEE/V+](#) [AD7175-](#)
[8BCPZ-RL7](#) [AD9530BCPZ](#) [MAX1436BECQ+D](#) [MAX16924GGM/VY+](#) [MAX11108AVB+T](#) [MAX11647EUA+T](#) [MCP33141-10T-E/MS](#)
[MCP33141D-05T-E/MS](#) [MCP33151D-05T-E/MS](#) [MCP3202T-CI/MS](#) [MAX11137ATI+T](#) [MAX11136ATI+T](#) [MAX11612EUA+T](#)
[MAX11212AEUB+T](#) [MAX11101EUB+T](#) [AD4001BCPZ-RL7](#) [MAX14002AAP+T](#) [MCP33141-05T-E/MS](#) [MAX11636EEE+T](#) [MCP33141D-](#)
[10T-E/MS](#) [MCP33151-05T-E/MS](#) [MCP33151-10T-E/MS](#) [MCP33151D-10T-E/MS](#) [MAX11259AWX+T](#) [AD7091R-5BRUZ-RL7](#)
[ADE1201ACCZ](#) [ADE1202ACCZ](#) [LTC1864CS8#PBF](#) [LTC2418CGNPBF](#) [LTC2433-1IMS#PBF](#) [LTC2442CGPBF](#) [LTC2400CS8#PBF](#)
[LTC2414CGNPBF](#) [TC7109ACKW](#) [TC7109CLW](#)