

## XL386 SOP8/XD386-1 DIP8/XL386-MS MSOP-8

### 1 Features

- Battery Operation
- Minimum External Parts
- Wide Supply Voltage Range: 4 V–12 V or 5 V–18 V
- Low Quiescent Current Drain: 4 mA
- Voltage Gains from 20 to 200
- Ground-Referenced Input
- Self-Centering Output Quiescent Voltage
- Low Distortion: 0.2% ( $A_V = 20$ ,  $V_S = 6\text{ V}$ ,  $R_L = 8\ \Omega$ ,  $P_O = 125\text{ mW}$ ,  $f = 1\text{ kHz}$ )
- Available in 8-Pin MSOP Package

### 2 Applications

- AM-FM Radio Amplifiers
- Portable Tape Player Amplifiers
- Intercoms
- TV Sound Systems
- Line Drivers
- Ultrasonic Drivers
- Small Servo Drivers
- Power Converters

### 3 Description

The 386 are power amplifiers designed for use in low voltage consumer applications. The gain is internally set to 20 to keep external part count low, but the addition of an external resistor and capacitor between pins 1 and 8 will increase the gain to any value from 20 to 200.

The inputs are ground referenced while the output automatically biases to one-half the supply voltage. The quiescent power drain is only 24 mW when operating from a 6-V supply, making the 386 ideal for battery operation.

### 4 Schematic

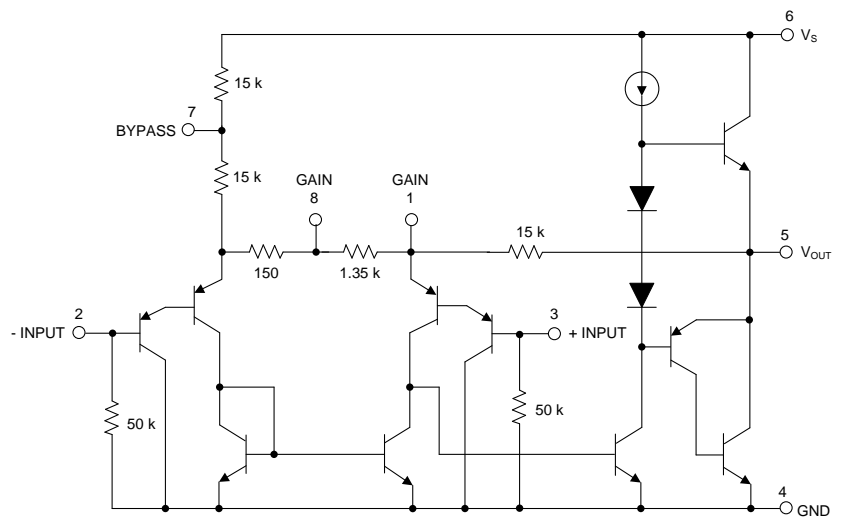

## 5 Pin Configuration and Functions

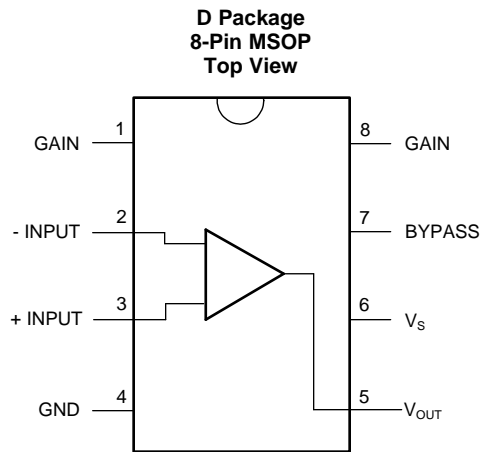

**Pin Functions**

PIN		TYPE	DESCRIPTION
NAME	NO.		
GAIN	1	–	Gain setting pin
–INPUT	2	I	Inverting input
+INPUT	3	I	Noninverting input
GND	4	P	Ground reference
V <sub>OUT</sub>	5	O	Output
V <sub>S</sub>	6	P	Power supply voltage
BYPASS	7	O	Bypass decoupling path
GAIN	8	–	Gain setting pin

## 6 Specifications

### 6.1 Absolute Maximum Ratings

over operating free-air temperature range (unless otherwise noted)<sup>(1)</sup>

		MIN	MAX	UNIT
Supply Voltage, V <sub>CC</sub>	XD386-1.XL386		15	V
			22	
Package Dissipation	XD386		1.25	W
	XL386		0.73	
	XL386-MS		0.595	
Input Voltage, V <sub>I</sub>		–0.4	0.4	V
Storage temperature, T <sub>stg</sub>		–65	150	°C

(1) Stresses beyond those listed under *Absolute Maximum Ratings* may cause permanent damage to the device. These are stress ratings only, which do not imply functional operation of the device at these or any other conditions beyond those indicated under *Recommended Operating Conditions*. Exposure to absolute-maximum-rated conditions for extended periods may affect device reliability.

### 6.2 ESD Ratings

		VALUE	UNIT
V <sub>(ESD)</sub> Electrostatic discharge	Human-body model (HBM), per ANSI/ESDA/JEDEC JS-001 <sup>(1)</sup>	±1000	V
	Charged-device model (CDM), per JEDEC specification JESD22-C101 <sup>(2)</sup>	±1000	

### 6.3 Recommended Operating Conditions

over operating free-air temperature range (unless otherwise noted)

		MIN	NOM	MAX	UNIT
V <sub>CC</sub>	Supply Voltage	4		12	V
	386	5		18	V
	Speaker Impedance	4			Ω
V <sub>I</sub>	Analog input voltage	-0.4		0.4	V
T <sub>A</sub>	Operating free-air temperature	0		70	°C

### 6.4 Thermal Information

THERMAL METRIC <sup>(1)</sup>		XL386	XL386	XD386	UNIT
		D (MSOP)	DGK (SOP)	P (DIP)	
		8	8	8	
R <sub>θJA</sub>	Junction-to-ambient thermal resistance	115.7	169.3	53.4	°C/W
R <sub>θJC(top)</sub>	Junction-to-case (top) thermal resistance	59.7	73.1	42.1	°C/W
R <sub>θJB</sub>	Junction-to-board thermal resistance	56.2	100.2	30.6	°C/W
ψ <sub>JT</sub>	Junction-to-top characterization parameter	12.4	9.2	19.0	°C/W
ψ <sub>JB</sub>	Junction-to-board characterization parameter	55.6	99.1	50.5	°C/W

### 6.5 Electrical Characteristics

over operating free-air temperature range (unless otherwise noted)

PARAMETER		TEST CONDITIONS	MIN	TYP	MAX	UNIT
V <sub>S</sub>	Operating Supply Voltage	XD386 XL386 XL386-MS	4		12	V
		XD386	5		18	
I <sub>Q</sub>	Quiescent Current	V <sub>S</sub> = 6 V, V <sub>IN</sub> = 0		4	8	mA
P <sub>OUT</sub>	Output Power	V <sub>S</sub> = 6 V, R <sub>L</sub> = 8 Ω, THD = 10% XD386 XL386 XL386-MS	250	325		mW
		V <sub>S</sub> = 9 V, R <sub>L</sub> = 8 Ω, THD = 10%	500	700		
		V <sub>S</sub> = 16 V, R <sub>L</sub> = 32 Ω, THD = 10%	700	100		
A <sub>V</sub>	Voltage Gain	V <sub>S</sub> = 6 V, f = 1 kHz		26		dB
		10 μF from Pin 1 to 8		46		
BW	Bandwidth	V <sub>S</sub> = 6 V, Pins 1 and 8 Open		300		kHz
THD	Total Harmonic Distortion	V <sub>S</sub> = 6 V, R <sub>L</sub> = 8 Ω, P <sub>OUT</sub> = 125 mW f = 1 kHz, Pins 1 and 8 Open		0.2%		
PSRR	Power Supply Rejection Ratio	V <sub>S</sub> = 6 V, f = 1 kHz, CBYPASS = 10 μF Pins 1 and 8 Open, Referred to Output		50		dB
R <sub>IN</sub>	Input Resistance			50		kΩ
I <sub>BIAS</sub>	Input Bias Current	V <sub>S</sub> = 6 V, Pins 2 and 3 Open		250		nA

6.6 Typical Characteristics

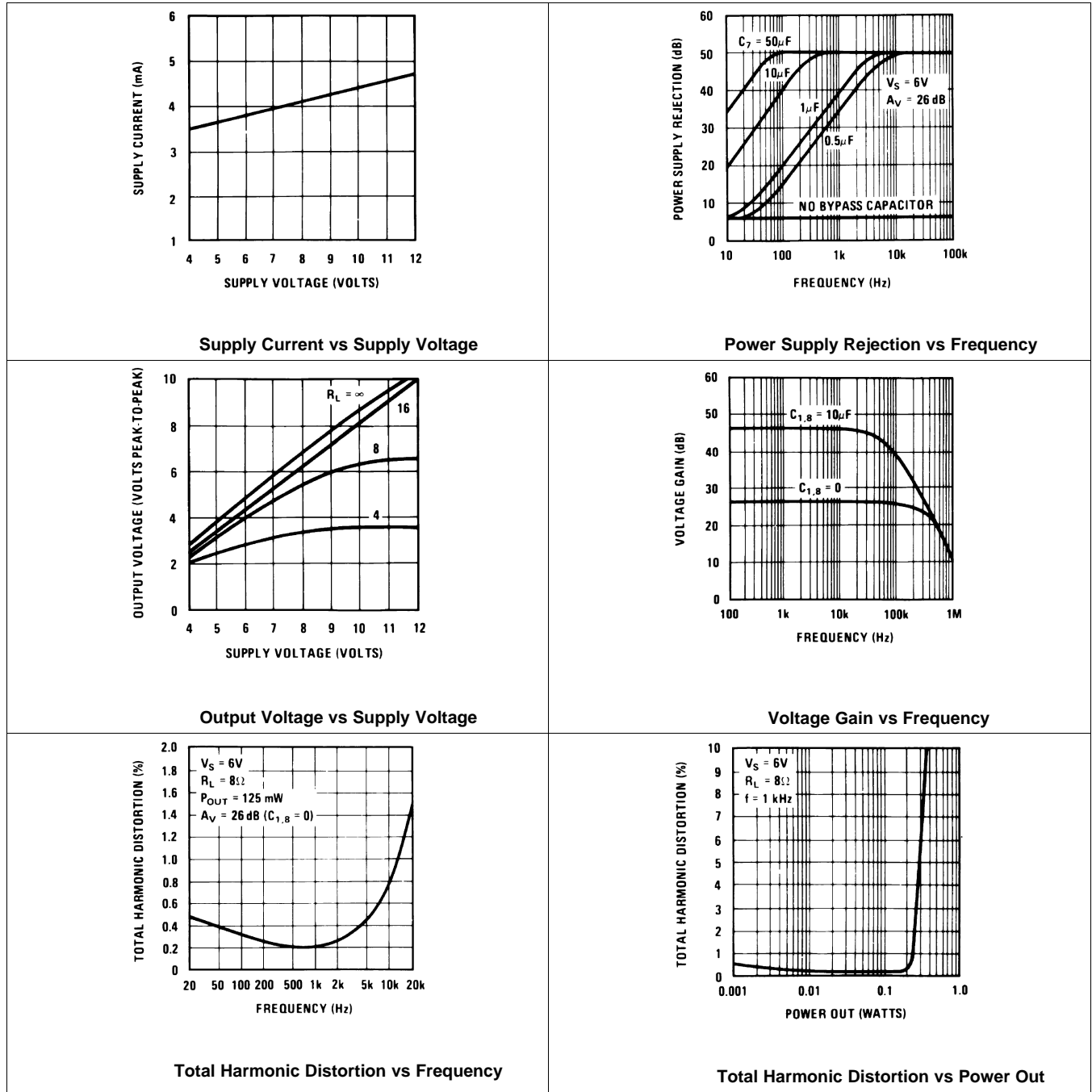

Typical Characteristics (continued)

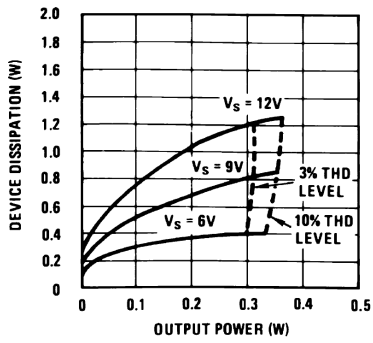

Device Dissipation vs Output Power

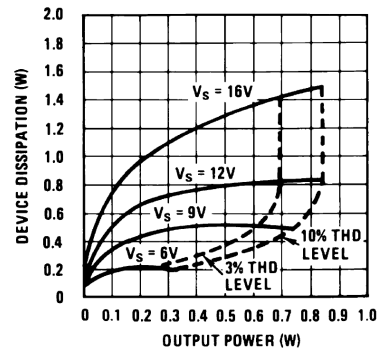

Device Dissipation vs Output Power

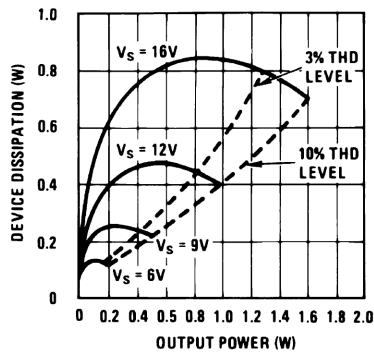

Device Dissipation vs Output Power

## 7 Detailed Description

### 7.1 Overview

The 386 is a mono low voltage amplifier that can be used in a variety of applications. It can drive loads from 4  $\Omega$  to 32  $\Omega$ . The gain is internally set to 20 but it can be modified from 20 to 200 by placing a resistor and capacitor between pins 1 and 8. This device comes in three different 8-pin packages as PDIP, SOIC and VSSOP to fit in different applications.

### 7.2 Functional Block Diagram

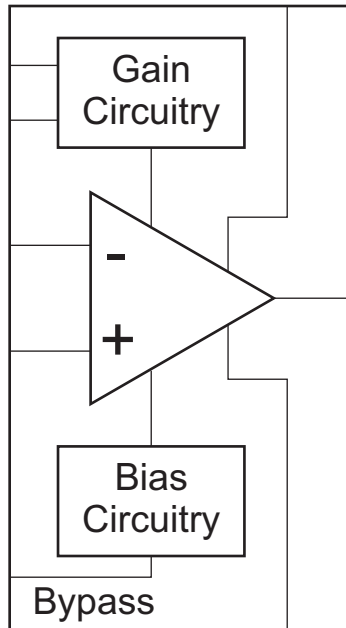

### 7.3 Feature Description

There is an internal 1.35-K $\Omega$  resistor that sets the gain of this device to 20. The gain can be modified from 20 to 200. Detailed information about gain setting can be found in the *Detailed Design Procedure* section.

### 7.4 Device Functional Modes

As this is an Op Amp it can be used in different configurations to fit in several applications. The internal gain setting resistor allows the 386 to be used in a very low part count system. In addition a series resistor can be placed between pins 1 and 5 to modify the gain and frequency response for specific applications.

## 8 Application and Implementation

### 8.1 Application Information

Below are shown different setups that show how the 386 can be implemented in a variety of applications.

### 8.2 Typical Application

#### 8.2.1 386 with Gain = 20

Figure 10 shows the minimum part count application that can be implemented using 386. Its gain is internally set to 20.

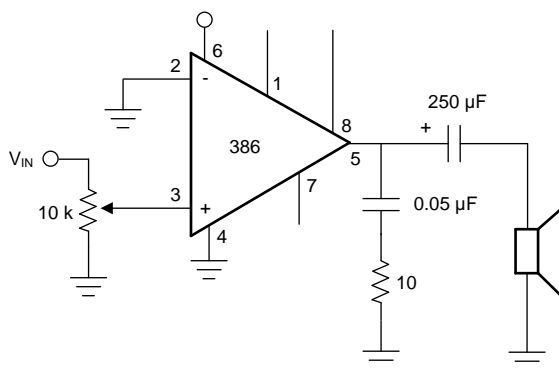

386 with Gain = 20

#### 8.2.1.1 Design Requirements

Table 1. Design Parameters

DESIGN PARAMETER	EXAMPLE VALUE
Load Impedance	4 Ω to 32 Ω
Supply Voltage	5 V to 12 V

#### 8.2.1.2 Detailed Design Procedure

##### 8.2.1.2.1 Gain Control

To make the 386 a more versatile amplifier, two pins (1 and 8) are provided for gain control. With pins 1 and 8 open the 1.35-kΩ resistor sets the gain at 20 (26 dB). If a capacitor is put from pin 1 to 8, bypassing the 1.35-kΩ resistor, the gain will go up to 200 (46 dB). If a resistor is placed in series with the capacitor, the gain can be set to any value from 20 to 200. Gain control can also be done by capacitively coupling a resistor (or FET) from pin 1 to ground.

Additional external components can be placed in parallel with the internal feedback resistors to tailor the gain and frequency response for individual applications. For example, we can compensate poor speaker bass response by frequency shaping the feedback path. This is done with a series RC from pin 1 to 5 (paralleling the internal 15-kΩ resistor). For 6 dB effective bass boost:  $R \approx 15 \text{ k}\Omega$ , the lowest value for good stable operation is  $R = 10 \text{ k}\Omega$  if pin 8 is open. If pins 1 and 8 are bypassed then  $R$  as low as 2 kΩ can be used. This restriction is because the amplifier is only compensated for closed-loop gains greater than 9.

**8.2.1.2.2 Input Biasing**

The schematic shows that both inputs are biased to ground with a 50 kΩ resistor. The base current of the input transistors is about 250 nA, so the inputs are at about 12.5 mV when left open. If the dc source resistance driving the 386 is higher than 250 kΩ it will contribute very little additional offset (about 2.5 mV at the input, 50 mV at the output). If the dc source resistance is less than 10 kΩ, then shorting the unused input to ground will keep the offset low (about 2.5 mV at the input, 50 mV at the output). For dc source resistances between these values we can eliminate excess offset by putting a resistor from the unused input to ground, equal in value to the dc source resistance. Of course all offset problems are eliminated if the input is capacitively coupled.

When using the 386 with higher gains (bypassing the 1.35 kΩ resistor between pins 1 and 8) it is necessary to bypass the unused input, preventing degradation of gain and possible instabilities. This is done with a 0.1 μF capacitor or a short to ground depending on the dc source resistance on the driven input.

**8.2.1.3 Application Curve**

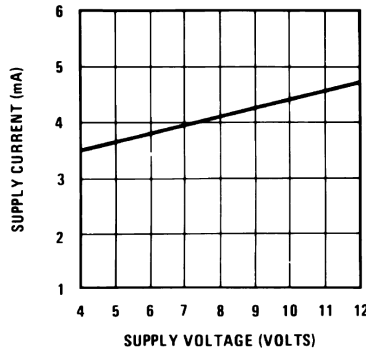

**Supply Current vs Supply Voltage**



## X-ON Electronics

Largest Supplier of Electrical and Electronic Components

*Click to view similar products for [Audio Amplifiers](#) category:*

*Click to view products by [XINLUDA](#) manufacturer:*

Other Similar products are found below :

[LV47002P-E](#) [MP7747DQ-LF-P](#) [AZ386MTR-E1](#) [NCP2811AFCT1G](#) [NCP2890AFCT2G](#) [NJM8068RB1-TE1](#) [NJW1194V-TE1](#) [LA4282-E](#)  
[LA4814JA-AE](#) [LC706200CM](#) [SSM2377ACBZ-R7](#) [FDA2100LV](#) [TDA2541](#) [TDA7385H](#) [TDA7391LV](#) [TDA7575BPDTR](#) [TDA7718NTR](#)  
[IS31AP2121-LQLS1](#) [IS31AP4915A-QFLS2-TR](#) [LA74309FA-BH](#) [421067X](#) [480263C](#) [NCP2820FCT2G](#) [STPA001](#) [TDA1515AQ](#) [TDA1520B](#)  
[TDA1591T](#) [TDA2051H](#) [TDA4850](#) [TDA7391PDUTR](#) [TDA7563BH](#) [TDA7718B](#) [LA4425F-E](#) [LA4742-E](#) [TDA7391PDU](#)  
[TDA7491MV13TR](#) [TDA749213TR](#) [TDA7563AH](#) [TDA7850H](#) [STK433-070GN-E](#) [E-TDA7391PDTR](#) [SSM2529ACBZ-R7](#) [SSM2518CBZ-](#)  
[R7](#) [MAX9890BEBL+T](#) [MAX98303EWE+T](#) [MAX98358EWL+](#) [MAX98304DEWL+T](#) [MAX97220DETE+T](#) [TS4962MEIJT](#) [TS4990EIJT](#)