

FEATURES

- 8-bit parallel storage register inputs
- Shift register has direct overriding load and clear
- Output capability: standard
- I_{CC} category: MSI

GENERAL DESCRIPTION

The 74HC597 are high-speed Si-gate CMOS devices and are pin compatible with low power Schottky TTL (LSTTL). They are specified in compliance with JEDEC standard no. 7A.

The 74HC597 consist each of an 8-bit storage register feeding a parallel-in, serial-out 8-bit shift register. Both the storage register and the shift register have positive edge-triggered clocks. The shift register also has direct load (from storage) and clear inputs.

QUICK REFERENCE DATA

GND = 0 V; T_{amb} = 25 °C; t_r = t_f = 6 ns

SYMBOL	PARAMETER	CONDITIONS	TYPICAL		UNIT
			HC	HCT	
t _{PHL} / t _{PLH}	propagation delay SH _{CP} to Q	C _L = 15 pF; V _{CC} = 5 V	17	20	ns
	ST _{CP} to Q		25	29	ns
	\overline{PL} to Q		21	26	ns
f _{max}	maximum clock frequency SH _{CP}		96	83	MHz
C _I	input capacitance		3.5	3.5	pF
C _{PD}	power dissipation capacitance per package	notes 1 and 2	29	32	pF

Notes

1. C_{PD} is used to determine the dynamic power dissipation (P_D in μW):

$$P_D = C_{PD} \times V_{CC}^2 \times f_i + \sum (C_L \times V_{CC}^2 \times f_o)$$
 where:
 f_i = input frequency in MHz
 f_o = output frequency in MHz
 $\sum (C_L \times V_{CC}^2 \times f_o)$ = sum of outputs
 C_L = output load capacitance in pF
 V_{CC} = supply voltage in V
2. For HC the condition is V_I = GND to V_{CC}
 For HCT the condition is V_I = GND to V_{CC} – 1.5 V

XD74HC597 DIP16 / XL74HC597 SOP16

PIN DESCRIPTION

PIN NO.	SYMBOL	NAME AND FUNCTION
8	GND	ground (0 V)
9	Q	serial data output
10	\overline{MR}	asynchronous reset input (active LOW)
11	SH _{CP}	shift clock input (LOW-to-HIGH, edge-triggered)
12	ST _{CP}	storage clock input (LOW-to-HIGH, edge-triggered)
13	\overline{PL}	parallel load input (active LOW)
14	D _S	serial data input
15, 1, 2, 3, 4, 5, 6, 7	D ₀ to D ₇	parallel data inputs
16	V _{CC}	positive supply voltage

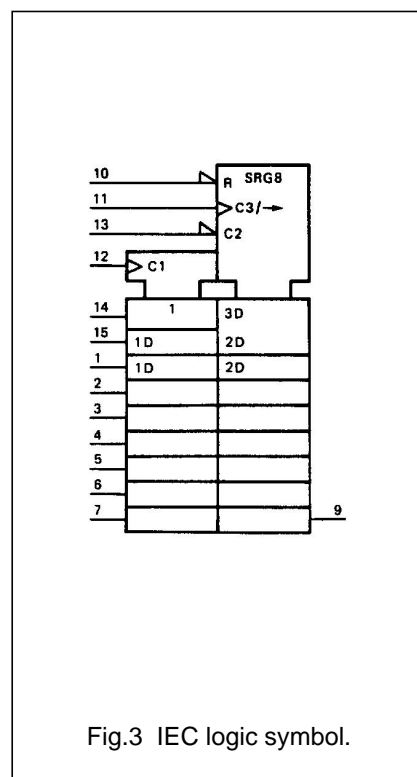
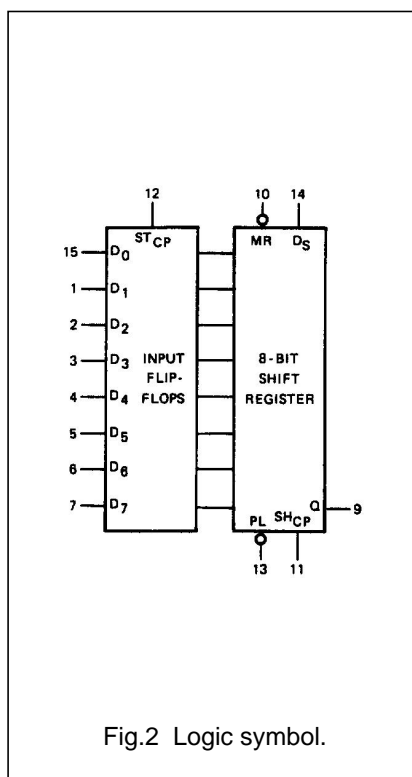
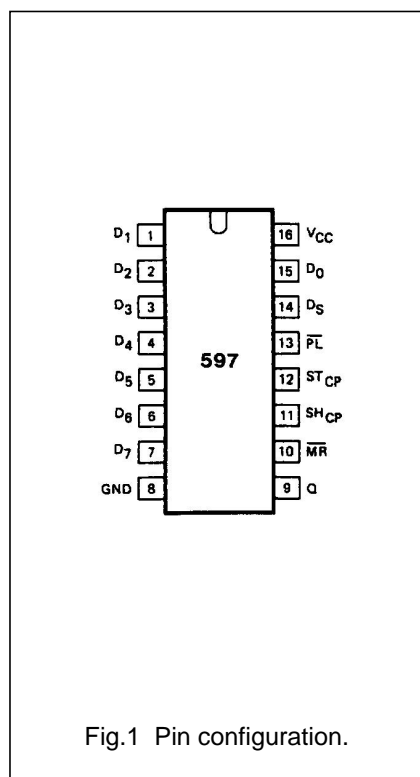

XD74HC597 DIP16 / XL74HC597 SOP16

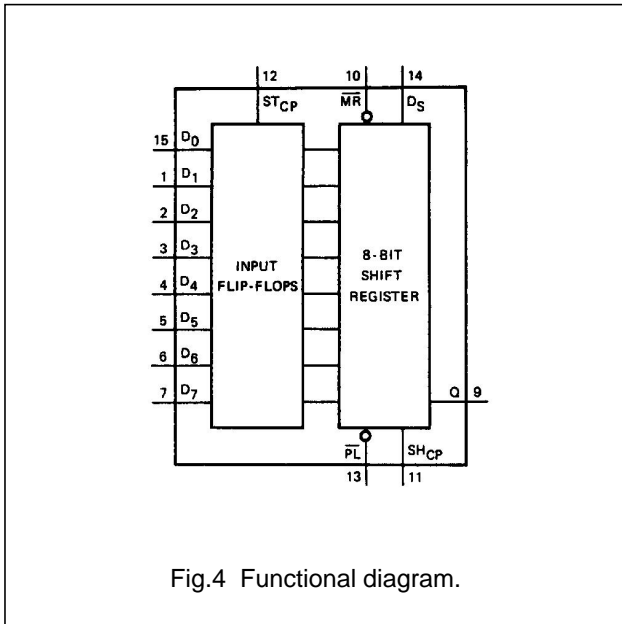

FUNCTION TABLE

ST _{CP}	SH _{CP}	\overline{PL}	\overline{MR}	FUNCTION
↑	X	X	X	data loaded to input latches
↑	X	L	H	data loaded from inputs to shift register
no clock edge	X	L	H	data transferred from input flip-flops to shift register
X	X	L	L	invalid logic, state of shift register indeterminate when signals removed
X	X	H	L	shift register cleared
X	↑	H	H	shift register clocked $Q_n = Q_{n-1}$, $Q_0 = D_S$

Notes

- H = HIGH voltage level
 L = LOW voltage level
 X = don't care
 ↑ = LOW-to-HIGH CP transition

XD74HC597 DIP16 / XL74HC597 SOP16

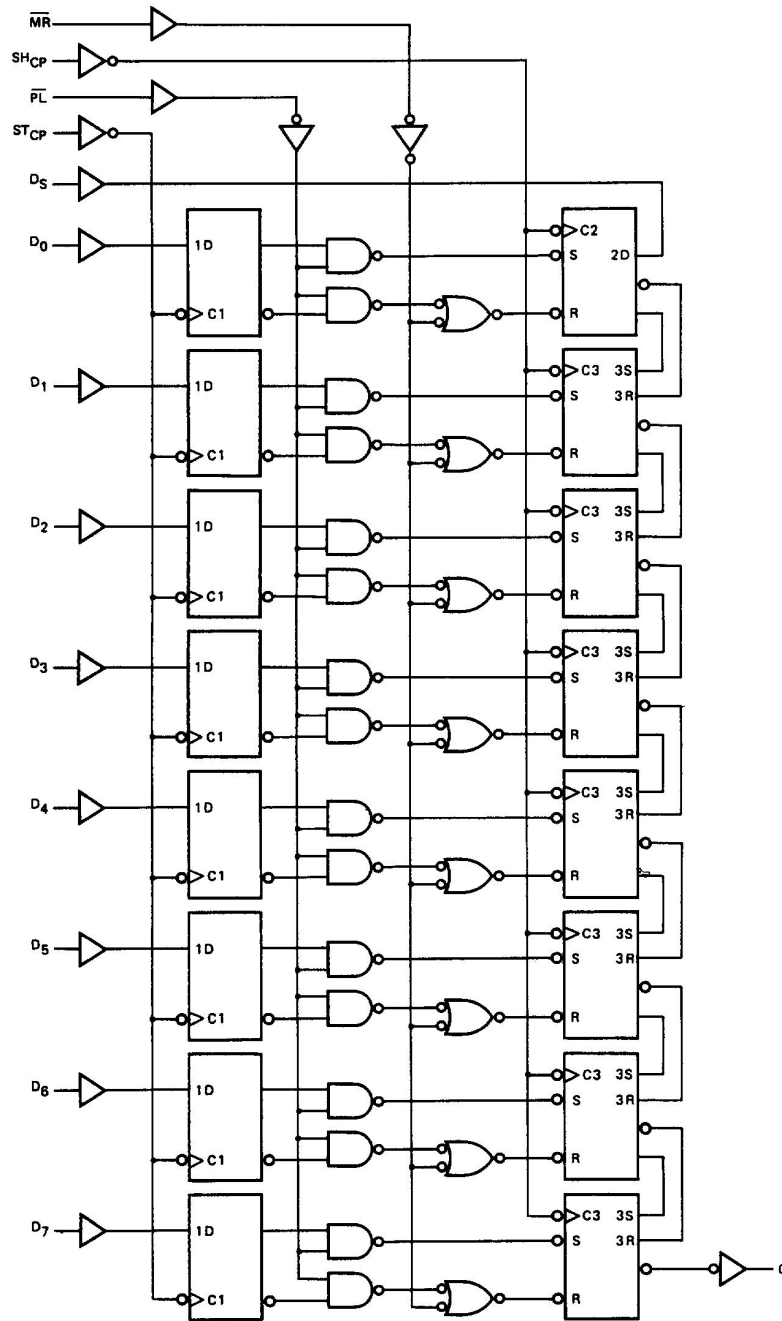

Fig.5 Logic diagram.

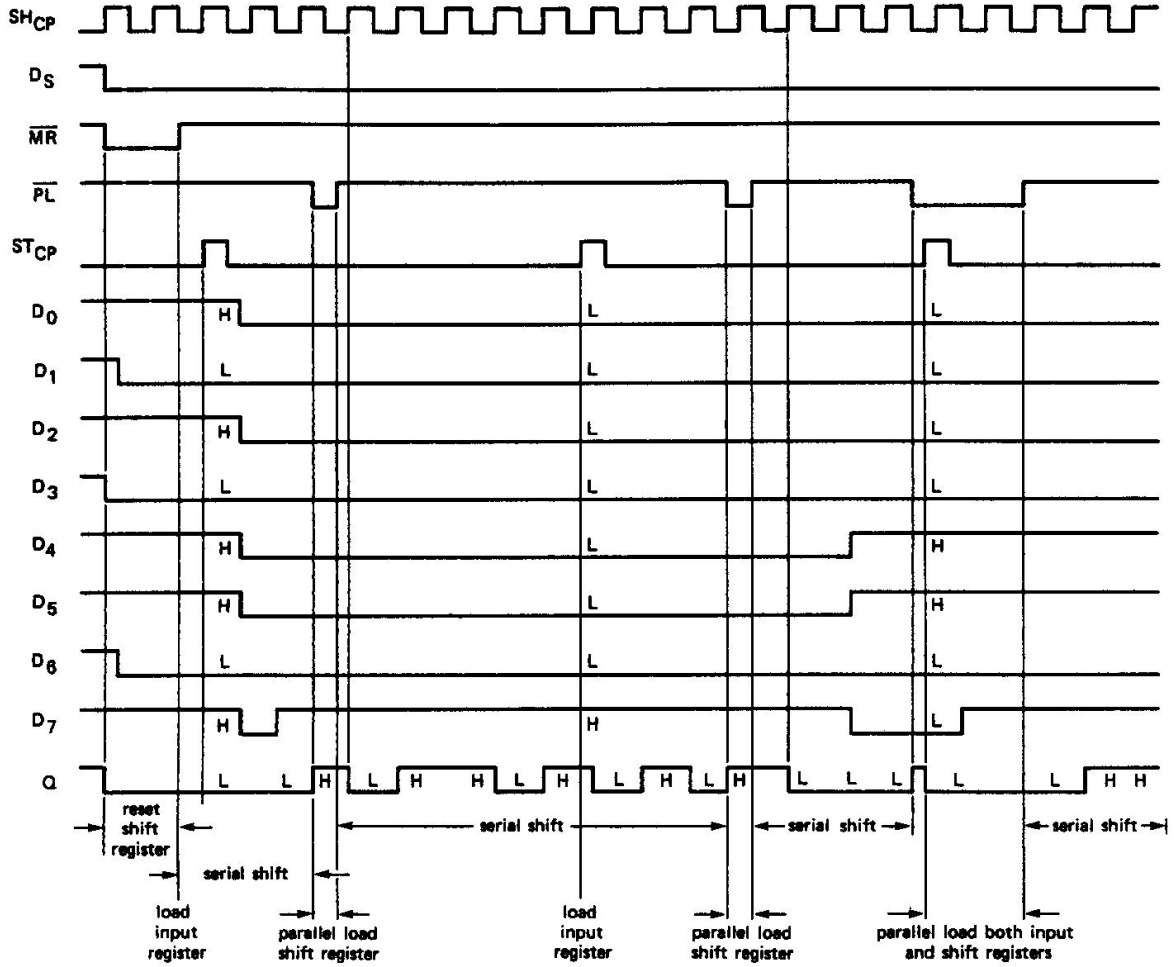

Fig.6 Timing diagram.

XD74HC597 DIP16 / XL74HC597 SOP16

Output capability: standard
 I_{CC} category: MSI

AC CHARACTERISTICS FOR 74HC

GND = 0 V; $t_r = t_f = 6$ ns; $C_L = 50$ pF

SYMBOL	PARAMETER	T_{amb} (°C)						UNIT	TEST CONDITIONS		
		74HC597							V_{CC} (V)	WAVEFORMS	
		+25			-40 to +85		-40 to +125				
		min.	typ.	max.	min.	max.	min.				max.
t_{PHL}/t_{PLH}	propagation delay SH _{CP} to Q		55 20 16	175 35 30		220 44 37		265 53 45	ns	2.0 4.5 6.0	Fig.7
t_{PHL}	propagation delay MR to Q		58 21 17	175 35 30		220 44 37		265 53 45	ns	2.0 4.5 6.0	Fig.8
t_{PHL}/t_{PLH}	propagation delay ST _{CP} to Q		80 29 23	250 50 43		315 63 54		375 75 64	ns	2.0 4.5 6.0	Fig.7
t_{PHL}/t_{PLH}	propagation delay PL to Q		69 25 20	215 43 37		270 54 46		325 65 55	ns	2.0 4.5 6.0	Fig.9
t_{THL}/t_{TLH}	output transition time		19 7 6	75 15 13		95 19 16		110 22 19	ns	2.0 4.5 6.0	Fig.9
t_W	ST _{CP} pulse width HIGH or LOW	80 16 14	11 4 3		100 20 17		120 24 20		ns	2.0 4.5 6.0	Fig.7
t_W	SH _{CP} pulse width HIGH or LOW	80 16 14	14 5 4		100 20 17		120 24 20		ns	2.0 4.5 6.0	Fig.7
t_W	MR pulse width LOW	80 16 14	22 8 6		100 20 17		120 24 20		ns	2.0 4.5 6.0	Fig.8
t_W	PL pulse width LOW	80 16 14	22 8 6		100 20 17		120 24 20		ns	2.0 4.5 6.0	Fig.9
t_{rem}	removal time MR to SH _{CP}	60 12 10	-3 -1 -1		75 15 13		90 18 15		ns	2.0 4.5 6.0	Fig.10
t_{su}	set-up time D _n to ST _{CP}	60 12 10	8 3 2		75 15 13		90 18 15		ns	2.0 4.5 6.0	Fig.11

XD74HC597 DIP16 / XL74HC597 SOP16

SYMBOL	PARAMETER	T _{amb} (°C)							UNIT	TEST CONDITIONS	
		74HC597								V _{CC} (V)	WAVEFORMS
		+25			-40 to +85		-40 to +125				
		min.	typ.	max.	min.	max.	min.	max.			
t _{su}	set-up time D _S to SH _{CP}	60 12 10	11 4 3		75 15 13		90 18 15		ns	2.0 4.5 6.0	Fig.11
t _{su}	set-up time \overline{PL} to SH _{CP}	60 12 10	11 4 3		75 15 13		90 18 15		ns	2.0 4.5 6.0	Fig.12
t _h	hold time D _n to ST _{CP}	5 5 5	-3 -1 -1		5 5 5		5 5 5		ns	2.0 4.5 6.0	Fig.11
t _h	hold time \overline{PL} , D _S to SH _{CP}	5 5 5	-6 -2 -2		5 5 5		5 5 5		ns	2.0 4.5 6.0	Fig.11
f _{max}	maximum pulse frequency SH _{CP}	6.0 30 35	29 87 104		4.8 24 28		4.0 20 24		MHz	2.0 4.5 6.0	Fig.7

Note to HCT types

The value of additional quiescent supply current (ΔI_{CC}) for a unit load of 1 is given in the family specifications. To determine ΔI_{CC} per input, multiply this value by the unit load coefficient shown in the table below.

INPUT	UNIT LOAD COEFFICIENT
D _S	0.25
D _n	0.30
\overline{PL} , \overline{MR}	1.50
ST _{CP} , SH _{CP}	1.50

XD74HC597 DIP16 / XL74HC597 SOP16

AC WAVEFORMS FOR 74HC597

GND = 0 V; $t_r = t_f = 6$ ns; $C_L = 50$ pF

SYMBOL	PARAMETER	T _{amb} (°C)								UNIT	TEST CONDITIONS	
		74HC597									V _{CC} (V)	WAVEFORMS
		+25			-40 to +85		-40 to +125					
		min.	typ.	max.	min.	max.	min.	max.				
t _{PHL} / t _{PLH}	propagation delay SH _{CP} to Q		23	40		50		60	ns	4.5	Fig.7	
t _{PHL}	propagation delay MR to Q		28	49		61		74	ns	4.5	Fig.8	
t _{PHL} / t _{PLH}	propagation delay ST _{CP} to Q		33	57		71		86	ns	4.5	Fig.7	
t _{PHL} / t _{PLH}	propagation delay PL to Q		30	52		65		78	ns	4.5	Fig.9	
t _{THL} / t _{TLH}	output transition time		7	15		19		22	ns	4.5	Fig.9	
t _w	SH _{CP} pulse width HIGH or LOW	16	7		20		24		ns	4.5	Fig.7	
t _w	ST _{CP} pulse width HIGH or LOW	16	6		20		24		ns	4.5	Fig.7	
t _w	$\overline{\text{MR}}$ pulse width LOW	25	14		31		38		ns	4.5	Fig.8	
t _w	$\overline{\text{PL}}$ pulse width LOW	20	10		25		30		ns	4.5	Fig.9	
t _{rem}	removal time $\overline{\text{MR}}$ to SH _{CP}	12	-2		15		18		ns	4.5	Fig.10	
t _{su}	set-up time D _n to ST _{CP}	12	5		15		18		ns	4.5	Fig.11	
t _{su}	set-up time D _S to SH _{CP}	12	2		15		18		ns	4.5	Fig.11	
t _{su}	set-up time $\overline{\text{PL}}$ to SH _{CP}	12	4		15		18		ns	4.5	Fig.12	
t _h	hold time D _n to ST _{CP}	5	-1		5		5		ns	4.5	Fig.11	
t _h	hold time $\overline{\text{PL}}$, D _S to SH _{CP}	5	-2		5		5		ns	4.5	Fig.11	
f _{max}	maximum pulse frequency SH _{CP}	30	75		24		20		MHz	4.5	Fig.7	

AC WAVEFORMS

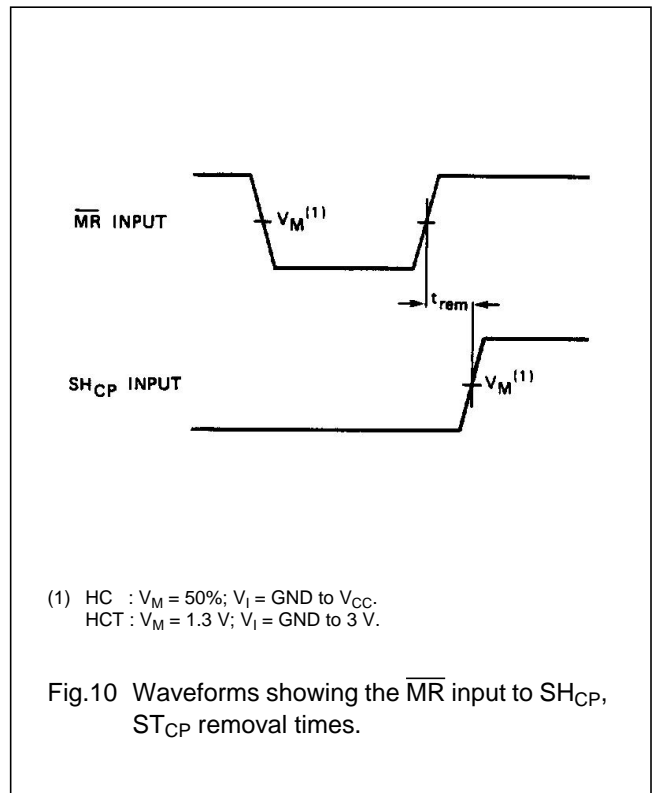
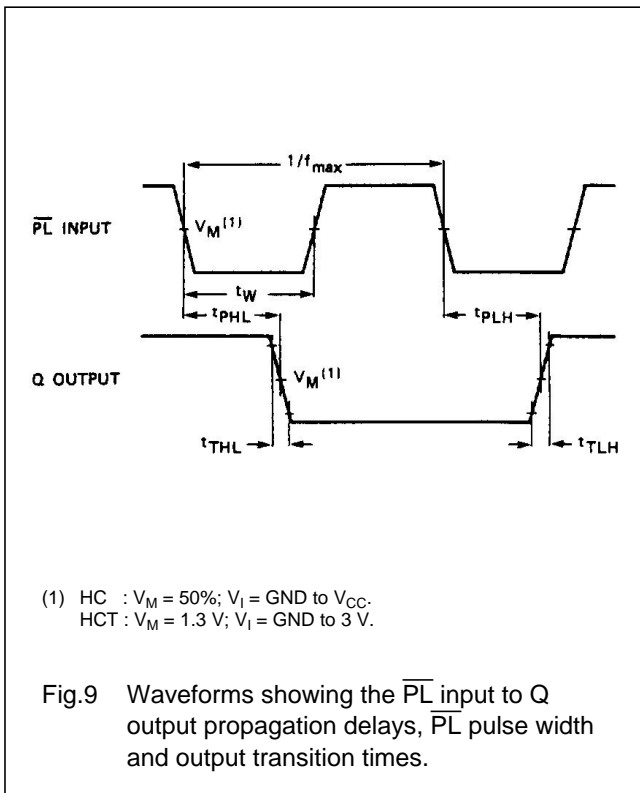
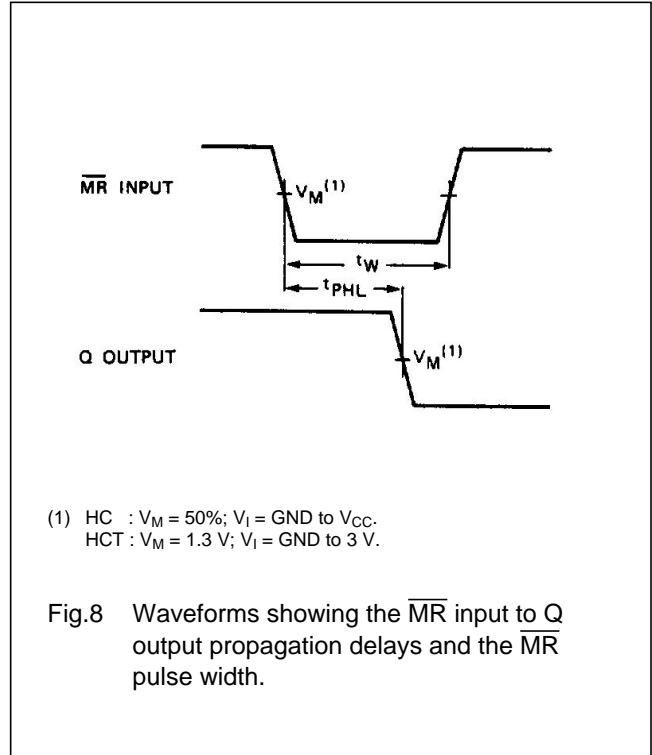
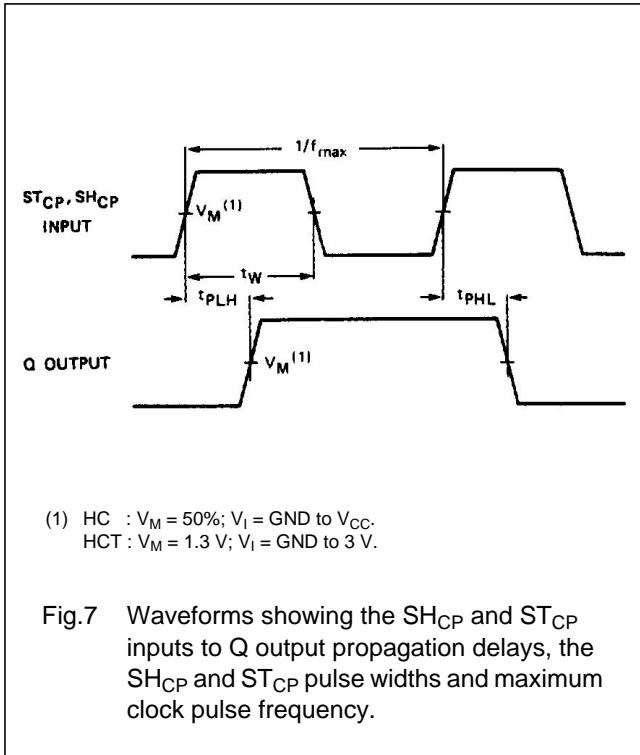

XD74HC597 DIP16 / XL74HC597 SOP16

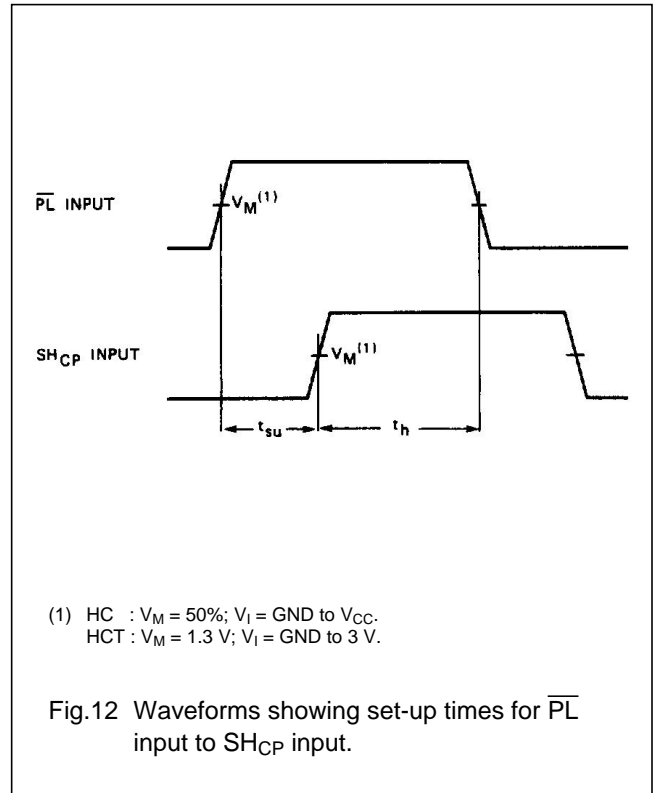
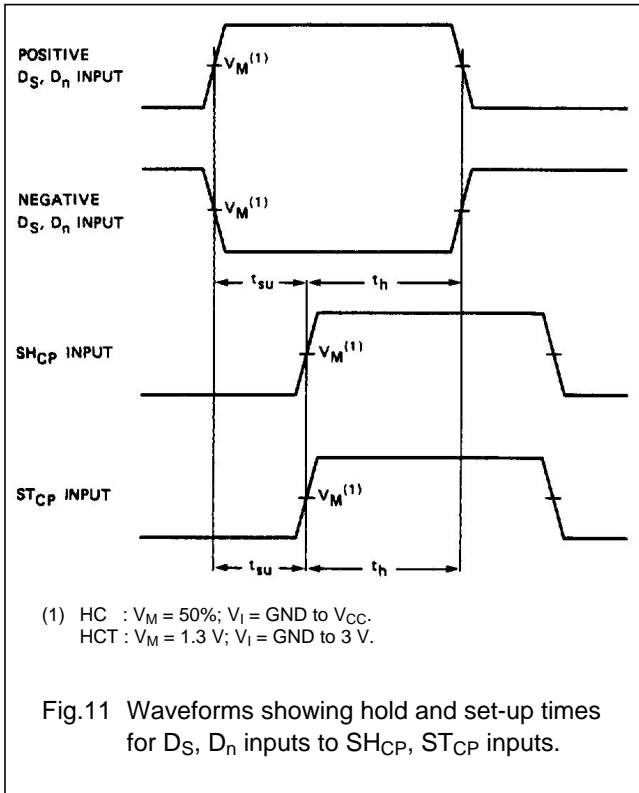

XD74HC597 DIP16 / XL74HC597 SOP16

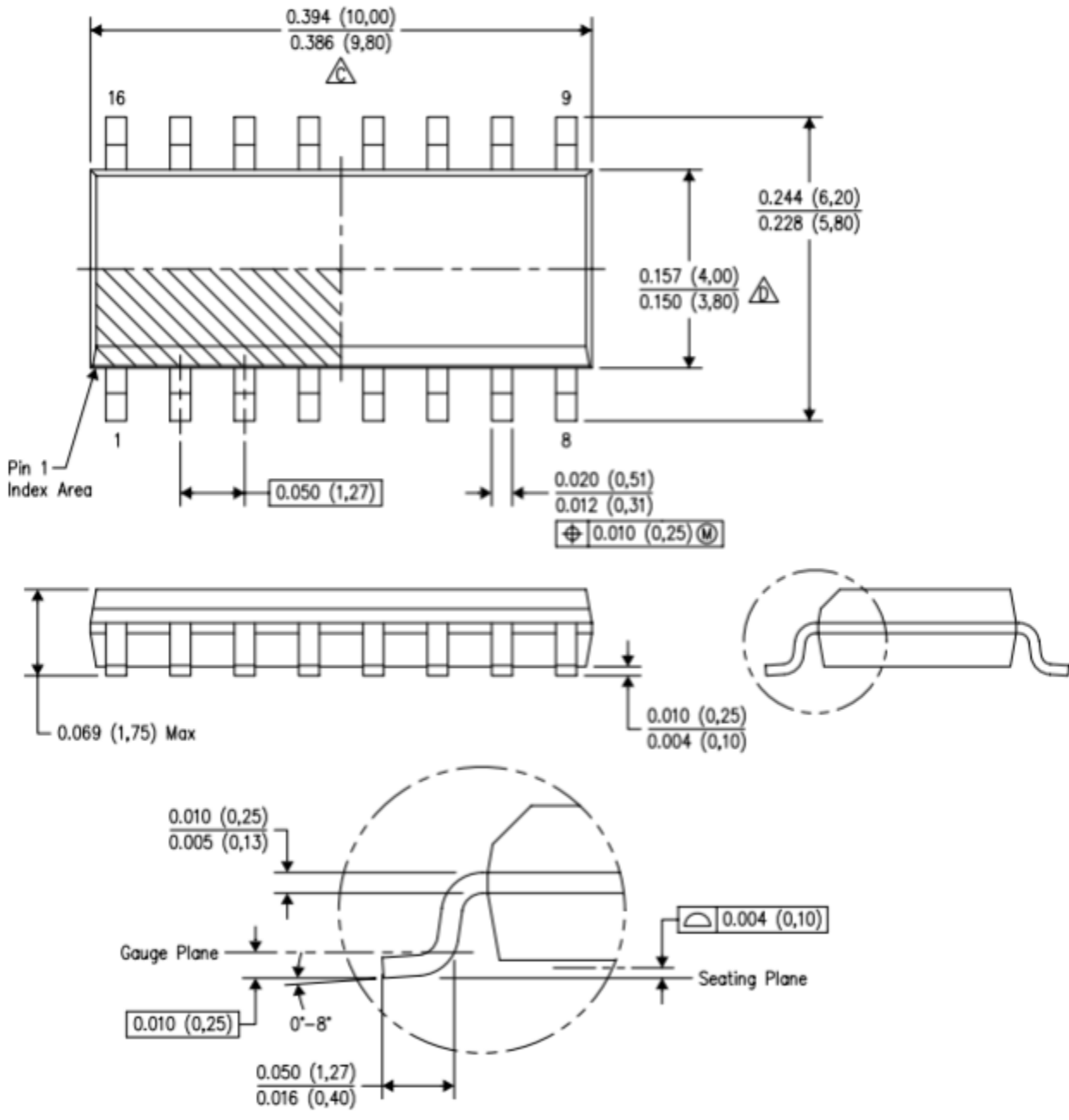

XD74HC597 DIP16 / XL74HC597 SOP16

DIP16

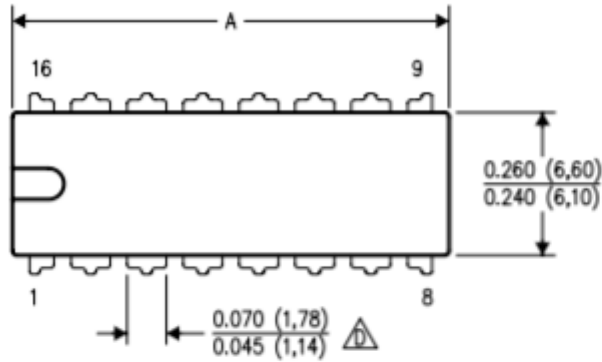

DIM \ PINS **	14	16	18	20
A MAX	0.775 (19,69)	0.775 (19,69)	0.920 (23,37)	1.060 (26,92)
A MIN	0.745 (18,92)	0.745 (18,92)	0.850 (21,59)	0.940 (23,88)
MS-001 VARIATION	AA	BB	AC	AD

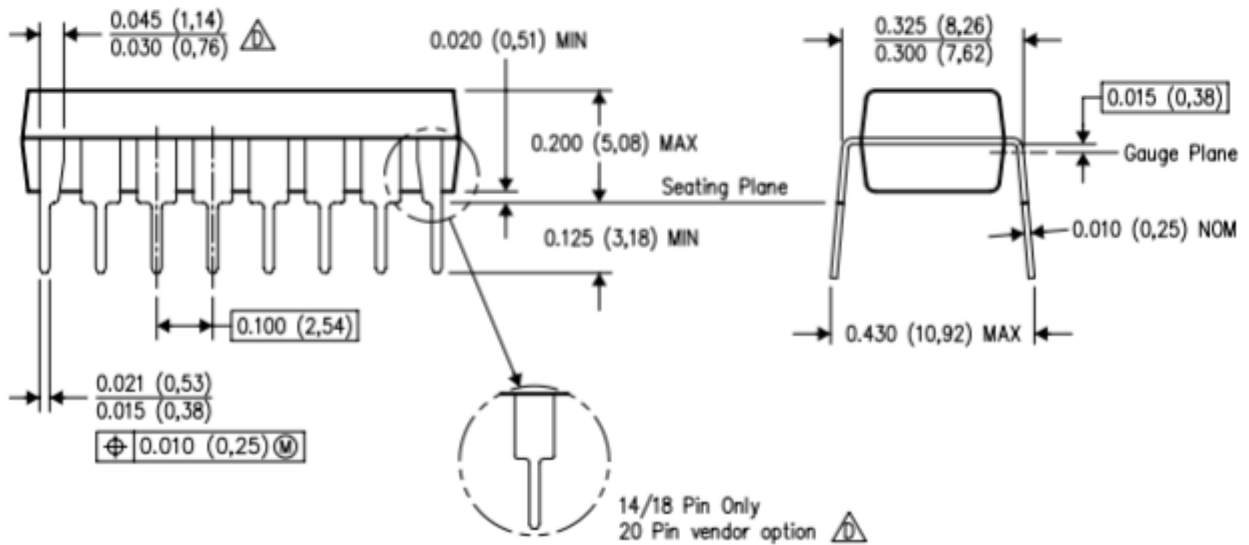

以上信息仅供参考. 如需帮助联系客服人员。谢谢 XINLUDA

X-ON Electronics

Largest Supplier of Electrical and Electronic Components

Click to view similar products for [Counter Shift Registers](#) category:

Click to view products by [XINLUDA](#) manufacturer:

Other Similar products are found below :

[5962-8956101EA](#) [MC10E446FNG](#) [74HC195N](#) [74HC4516N](#) [74HCT182N](#) [HEF4021BD](#) [HEF4534BP](#) [MC144111P](#) [NLV74HC165ADTR2G](#)
[5962-9172201M2A](#) [MC74HC597ADG](#) [MC100EP142MNG](#) [MC100EP016AMNG](#) [5962-9172201MFA](#) [MC74HC164BDR2G](#)
[TC74HC165AP\(F\)](#) [74AHC164T14-13](#) [MC74LV594ADR2G](#) [NLV14094BDTR2G](#) [NLV74HC595ADTG](#) [MC74HC165AMNTWG](#)
[TPIC6C595PWG4](#) [74VHC164MTCX](#) [CD74HC195M96](#) [CD4073BM96](#) [CD4053BM96](#) [MM74HC595MTCX](#) [74HCT164T14-13](#)
[74HCT164S14-13](#) [74HC4094D-Q100J](#) [NLV14014BFELG](#) [NLV74HC165ADR2G](#) [NLV74HC589ADTR2G](#) [NPIC6C595D-Q100,11](#)
[NPIC6C595PW,118](#) [NPIC6C596ADJ](#) [NPIC6C596APW-Q100J](#) [NPIC6C596D-Q100,11](#) [BU4094BCF-E2](#) [BU4094BCFV-E2](#) [74HC164D14](#)
[74HC164T14-13](#) [TPIC6C596PWRG4](#) [STPIC6D595MTR](#) [STP08CP05MTR](#) [CD74HC123E](#) [74HC164D.653](#) [74HC165D.653](#)
[74HCT165D.652](#) [74HCT164D.652](#)