

This monolithic decimal decoder consists of eight inverters and ten four-input NAND gates. The inverters are connected in pairs to make BCD input data available for decoding by NAND gates. Full decoding of valid input logic ensures that all outputs remain off for all invalid input conditions.

Pin Arrangement

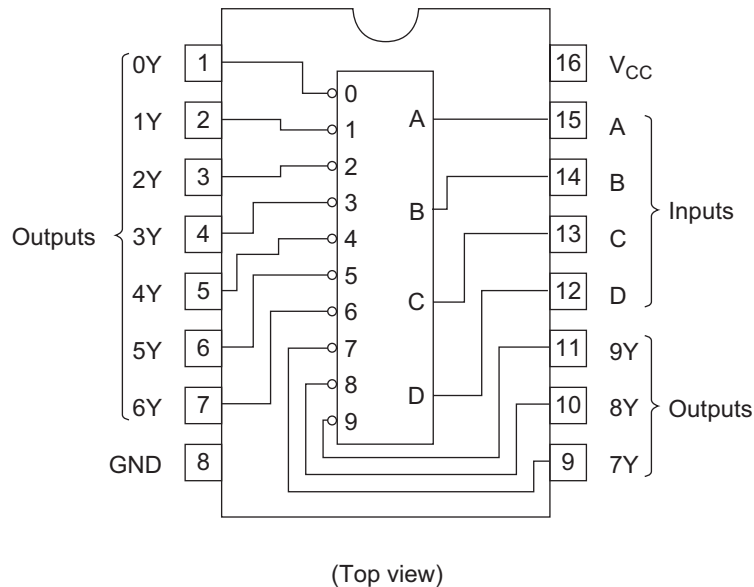

Function Table

No.	BCD input				Decimal output									
	D	C	B	A	0	1	2	3	4	5	6	7	8	9
0	L	L	L	L	L	H	H	H	H	H	H	H	H	H
1	L	L	L	H	H	L	H	H	H	H	H	H	H	H
2	L	L	H	L	H	H	L	H	H	H	H	H	H	H
3	L	L	H	H	H	H	H	L	H	H	H	H	H	H
4	L	H	L	L	H	H	H	H	L	H	H	H	H	H
5	L	H	L	H	H	H	H	H	H	L	H	H	H	H
6	L	H	H	L	H	H	H	H	H	H	L	H	H	H
7	L	H	H	H	H	H	H	H	H	H	H	L	H	H
8	H	L	L	L	H	H	H	H	H	H	H	H	L	H
9	H	L	L	H	H	H	H	H	H	H	H	H	H	L
Invalid	H	L	H	L	H	H	H	H	H	H	H	H	H	H
	H	L	H	H	H	H	H	H	H	H	H	H	H	H
	H	H	L	L	H	H	H	H	H	H	H	H	H	H
	H	H	L	H	H	H	H	H	H	H	H	H	H	H
	H	H	H	L	H	H	H	H	H	H	H	H	H	H

H; high level, L; low level

Block Diagram

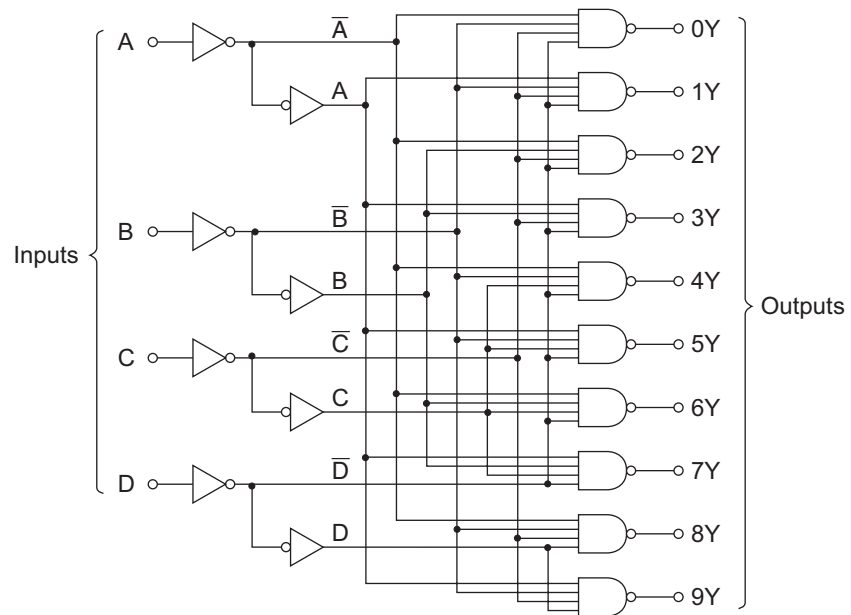

Absolute Maximum Ratings

Item	Symbol	Ratings	Unit
Supply voltage	V_{CC}	7	V
Input voltage	V_{IN}	7	V
Power dissipation	P_T	400	mW
Storage temperature	T_{stg}	-65 to +150	°C

Note: Voltage value, unless otherwise noted, are with respect to network ground terminal.

Recommended Operating Conditions

Item	Symbol	Min	Typ	Max	Unit
Supply voltage	V_{CC}	4.75	5.00	5.25	V
Output current	I_{OH}	—	—	-400	μA
	I_{OL}	—	—	8	mA
Operating temperature	T_{opr}	-20	25	75	$^{\circ}C$

Electrical Characteristics

(Ta = -20 to +75 $^{\circ}C$)

Item	Symbol	min.	typ.*	max.	Unit	Condition
Input voltage	V_{IH}	2.0	—	—	V	
	V_{IL}	—	—	0.8	V	
Output voltage	V_{OH}	2.7	—	—	V	$V_{CC} = 4.75 V, V_{IH} = 2 V, V_{IL} = 0.8 V, I_{OH} = -400 \mu A$
	V_{OL}	—	—	0.5	V	$V_{CC} = 4.75 V, V_{IH} = 2 V, V_{IL} = 0.8 V$
		—	—	0.4		
Input current	I_{IH}	—	—	20	μA	$V_{CC} = 5.25 V, V_I = 2.7 V$
	I_{IL}	—	—	-0.4	mA	$V_{CC} = 5.25 V, V_I = 0.4 V$
	I_I	—	—	0.1	mA	$V_{CC} = 5.25 V, V_I = 7 V$
Short-circuit output current	I_{OS}	-20	—	-100	mA	$V_{CC} = 5.25 V$
Supply current	I_{CC}^{**}	—	7	13	mA	$V_{CC} = 5.25 V$
Input clamp voltage	V_{IK}	—	—	-1.5	V	$V_{CC} = 4.75 V, I_{IN} = -18 mA$

Notes: * $V_{CC} = 5 V, T_a = 25^{\circ}C$ ** V_{CC} is measured with all outputs and all inputs grounded.

Switching Characteristics

(V_{CC} = 5 V, Ta = 25 $^{\circ}C$)

Item	Symbol	min.	typ.	max.	Unit	Condition
Propagation delay time	2 Stage	—	15	25	ns	$C_L = 15 pF, R_L = 2 k\Omega$
	3 Stage		20	30		
	2 Stage	—	15	25	ns	
	3 Stage		20	30		

Testing Method

Test Circuit

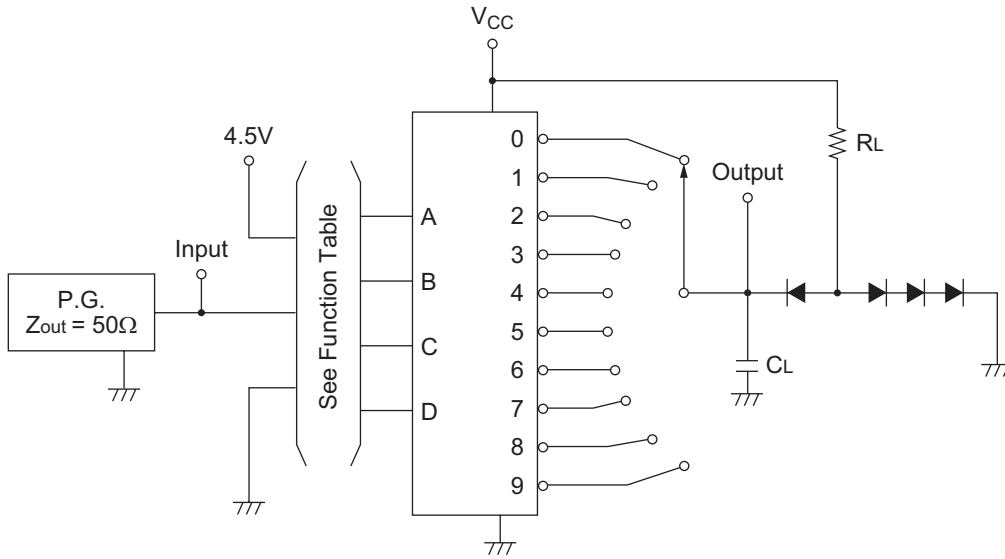

- Notes:
1. All diodes are 1S2074(H).
 2. C_L includes probe and jig capacitance.

Waveform

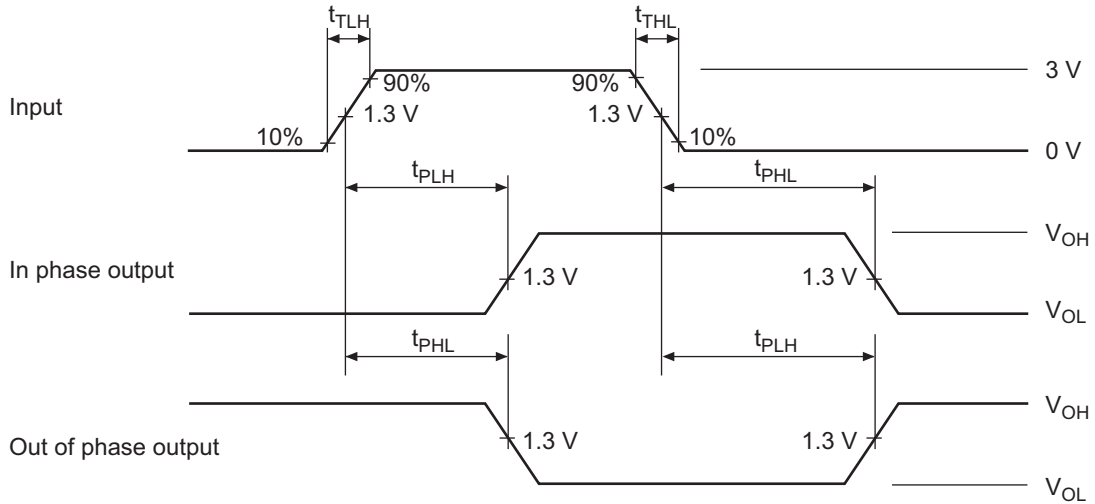

Note: Input pulse: $t_{TLH} \leq 15 \text{ ns}$, $t_{THL} \leq 6 \text{ ns}$, $\text{PRR} = 1 \text{ MHz}$, duty cycle 50%.

DIP16

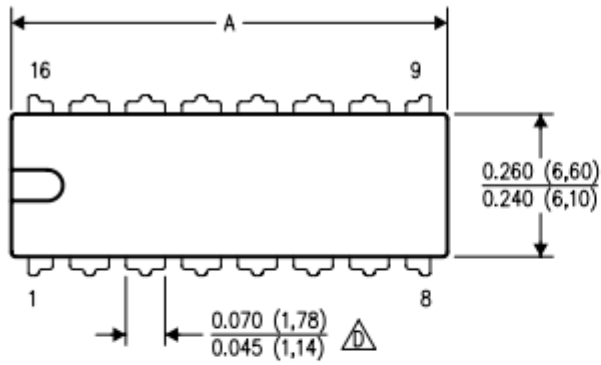

DIM \ PINS **	14	16	18	20
A MAX	0.775 (19,69)	0.775 (19,69)	0.920 (23,37)	1.060 (26,92)
A MIN	0.745 (18,92)	0.745 (18,92)	0.850 (21,59)	0.940 (23,88)
MS-001 VARIATION	AA	BB	AC	AD

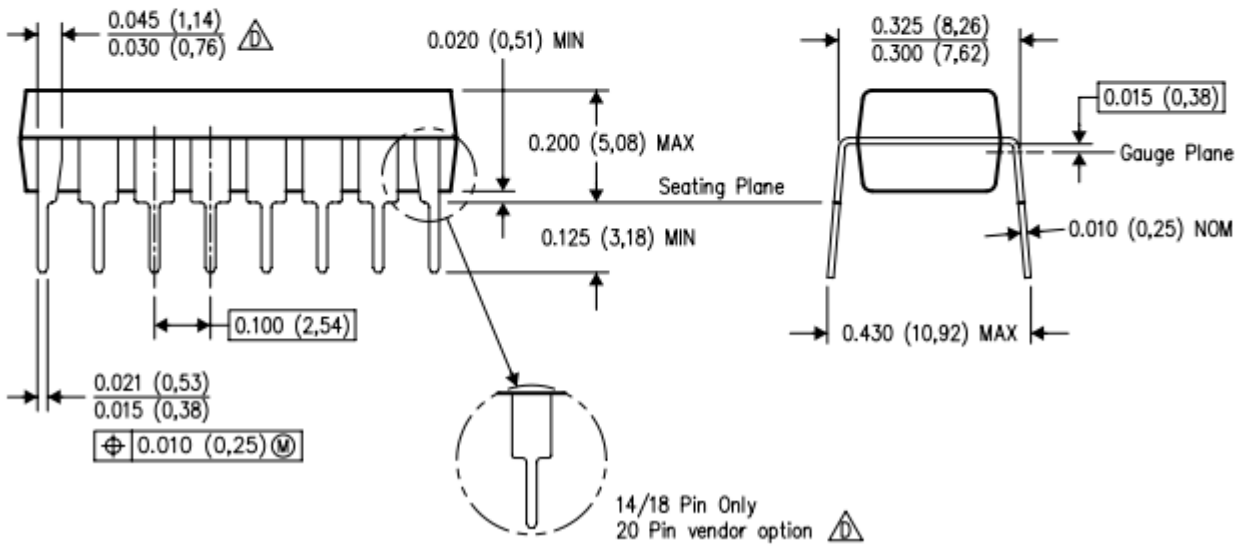

以上信息仅供参考. 如需帮助联系客服人员。谢谢 XINLUDA

X-ON Electronics

Largest Supplier of Electrical and Electronic Components

Click to view similar products for [Interface - CODECs](#) category:

Click to view products by [XINLUDA](#) manufacturer:

Other Similar products are found below :

[CS4205-KQZ](#) [ZL38015QCG1](#) [MAX98090AEWJ+T](#) [WM9713CLGEFLV](#) [LE58QL061BVC](#) [MAX9867ETJ+G3U](#) [ADAU1777BCBZRL](#)
[WM8944BECS/R](#) [TDA7293V-E](#) [WM8998ECS/R](#) [WM8778SEDS/V](#) [CS42L73-CRZR](#) [WM8750CJLGEFL](#) [STA529Q](#) [SSM2603CPZ-REEL](#)
[TLV320AIC14IDBT](#) [TLV320AIC23BIPWRQ1](#) [TLV320AIC23IPW](#) [TVP5151PBSR](#) [MAX98090BETL+](#) [MAX98089ETN+](#)
[MAX98089ETNT](#) [TLV320AIC34IZASR](#) [TLV320AIC3262IYZFR](#) [SA612AD/01.112](#) [ADAU1372BCPZ-RL](#) [MAX98090AETL+](#)
[MAX9880AETM](#) [WM8962ECSN/R](#) [TLV320DAC3203IRGER](#) [WM8904CGEFL/RV](#) [6PAIC3106IRGZRQ1](#) [CS42436-DMZ](#)
[TSCS25A3X1NDGXZAX](#) [BU94502CMUV-E2](#) [TDA8932BT/N2.112](#) [TDA8954J/N1.112](#) [ICS512MLF](#) [92HD73C1T5PRGIC1X](#)
[92HD73C1X5PRGXC1X](#) [SSM2167-1RMZ](#) [AD1836AASZ](#) [AD1836ACSZ](#) [AD1928YSTZ](#) [AD1937WBSTZ](#) [AD1938WBSTZ](#)
[AD1939WBSTZ](#) [AD73311ARSZ](#) [AD73311ARZ](#) [AD73311LARUZ](#)