

## Description

XDXL/17358 series are dual operational amplifier that provide high gain and internal phase compensation, with single power supply. They can be widely applied to control equipments and to general use.

## Features

- Wide range of supply voltage, and single power supply used
- Wide range of common mode voltage, and possible to operate with an input about 0 V, and output around 0 V is available
- Frequency characteristics and input bias current are temperature compensated
- Low electro-magnetic susceptibility level

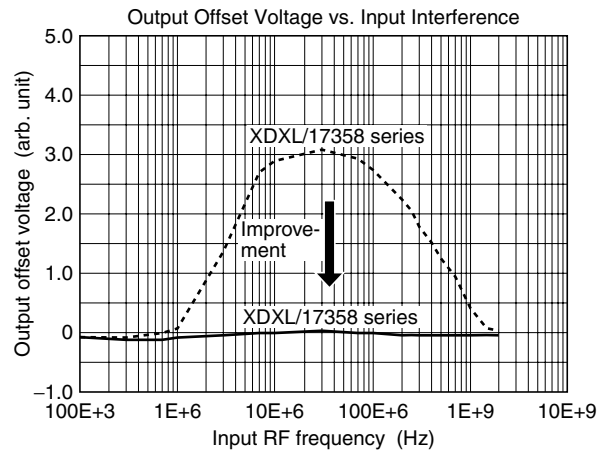
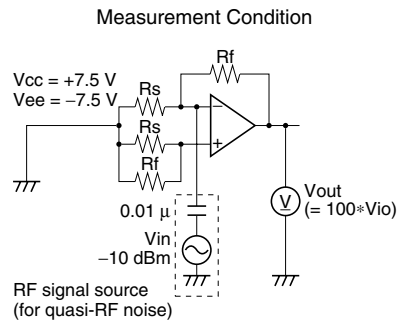

**Pin Arrangement**

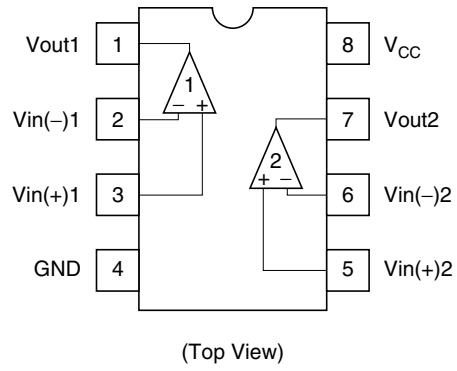

**Circuit Schematic (1/2)**

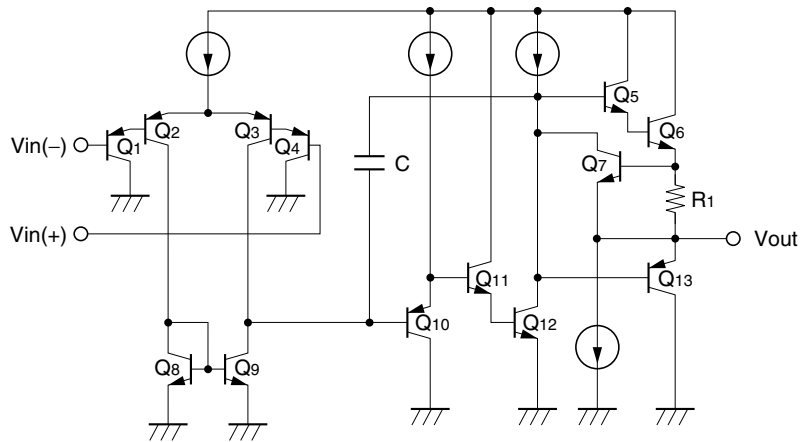

**Absolute Maximum Ratings**

(Ta = 25°C)

Item	Symbol	Ratings	
		XDXL/17358	Unit
Supply voltage	V <sub>CC</sub> 32	V	
Sink current	I <sub>sink</sub>	50	mA
Power dissipation	P <sub>T</sub>	570 * <sup>1</sup>	mW
Common mode input voltage	V <sub>CM</sub>	-0.3 to V <sub>CC</sub>	V
Differential input voltage	V <sub>in</sub> (diff)	±V <sub>CC</sub>	V
Operating temperature	T <sub>opr</sub>	-40 to +85	°C
Storage temperature	T <sub>stg</sub>	-55 to +125	°C

- Notes: 1. This is the allowable values up to Ta = 50°C. Derate by 8.3 mW/°C.  
 2. These are the allowable values up to Ta = 25°C mounting in air.  
 When it is mounted on glass epoxy board of 40 mm × 40 mm × 1.5 mmt with 30% wiring density, the allowable value is 570 mW up to Ta = 45°C. If Ta > 45°C, derate by 7.14 mW/°C.

**Electrical Characteristics** $(V_{CC} = +15\text{ V}, T_a = 25^\circ\text{C})$ 

Item	Symbol	Min	Typ	Max	Unit	Test Conditions
Input offset voltage	$V_{IO}$	—	3	7	mV	$V_{CM} = 7.5\text{V}, R_S = 50\Omega, R_f = 50\text{k}\Omega$
Input offset current	$I_{IO}$	—	5	50	nA	$V_{CM} = 7.5\text{V}, I_{IO} =  I_{I(+)} - I_{I(-)} $
Input bias current	$I_{IB}$	—	30	250	nA	$V_{CM} = 7.5\text{V}$
Power source rejection ratio	PSRR	—	93	—	dB	$R_S = 1\text{k}\Omega, R_f = 100\text{k}\Omega$
Voltage gain	$A_{VD}$	75	90	—	dB	$R_L = \infty, R_S = 1\text{k}\Omega, R_f = 100\text{k}\Omega$
Common mode rejection ratio	CMR	—	80	—	dB	$R_S = 50\Omega, R_f = 5\text{k}\Omega$
Common mode input voltage range	$V_{CM(+)}$	13.5	—	—	V	$R_S = 1\text{k}\Omega, R_f = 100\text{k}\Omega$
	$V_{CM(-)}$	—	—	-0.3	V	$R_S = 1\text{k}\Omega, R_f = 100\text{k}\Omega$
Peak-to-peak output voltage	$V_{op-p}$	—	13.6	—	V	$f = 100\text{Hz}, R_L = 20\text{k}\Omega, R_S = 1\text{k}\Omega, R_f = 100\text{k}\Omega$
Output source current	$I_{osource}$	20	40	—	mA	$V_{IN}^+ = 1\text{V}, V_{IN}^- = 0\text{V}, V_{OH} = 10\text{V}$
Output sink current	$I_{osink}$	10	20	—	mA	$V_{IN}^- = 1\text{V}, V_{IN}^+ = 0\text{V}, V_{OL} = 2.5\text{V}$
Output sink current	$I_{osink}$	15	50	—	$\mu\text{A}$	$V_{IN}^- = 1\text{V}, V_{IN}^+ = 0\text{V}, V_{out} = 200\text{mV}$
Supply current	$I_{CC}$	—	0.8	2	mA	$V_{IN} = \text{GND}, R_L = \infty$
Slew rate	SR	—	0.2	—	V/ $\mu\text{s}$	$R_L = \infty, V_{CM} = 7.5\text{V}, f = 1.5\text{kHz}$
Channel separation	CS	—	120	—	dB	$f = 1\text{kHz}$

### Characteristic Curves

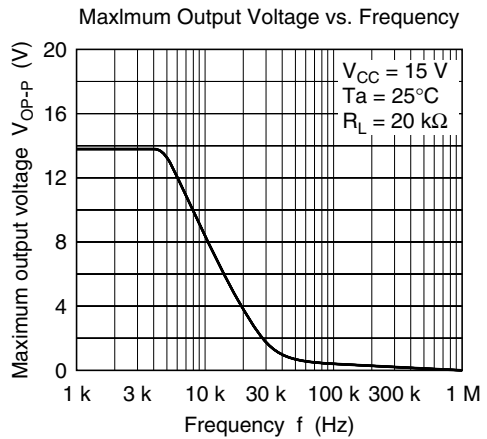
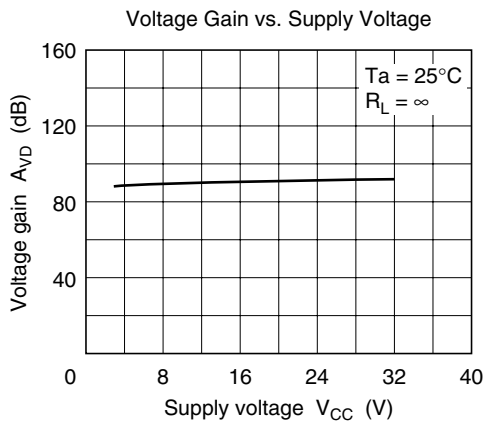
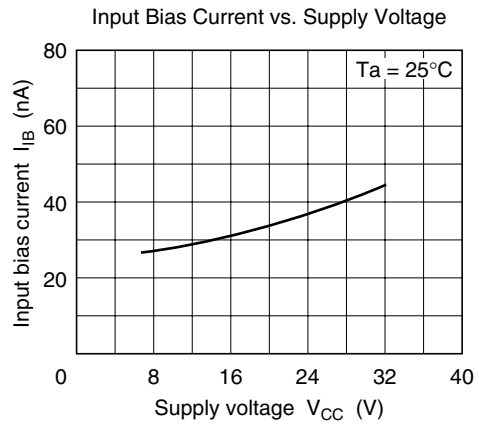
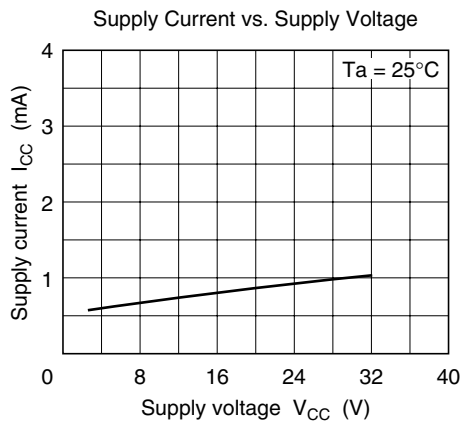
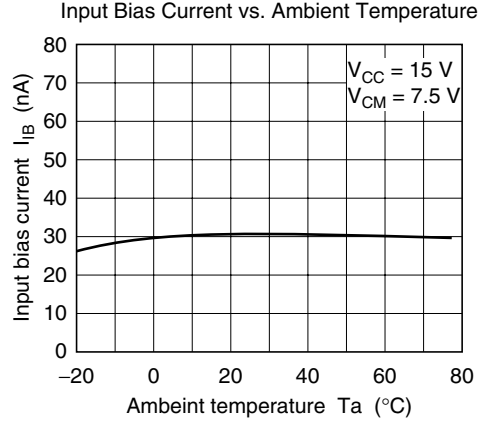
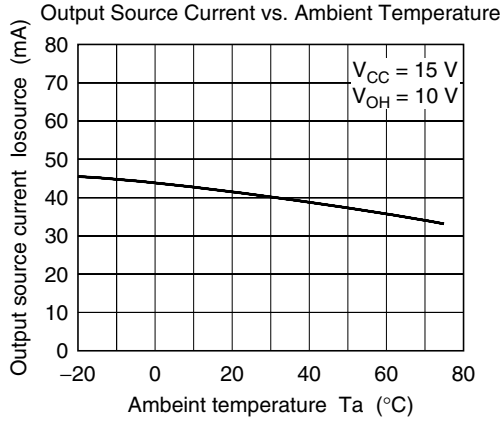

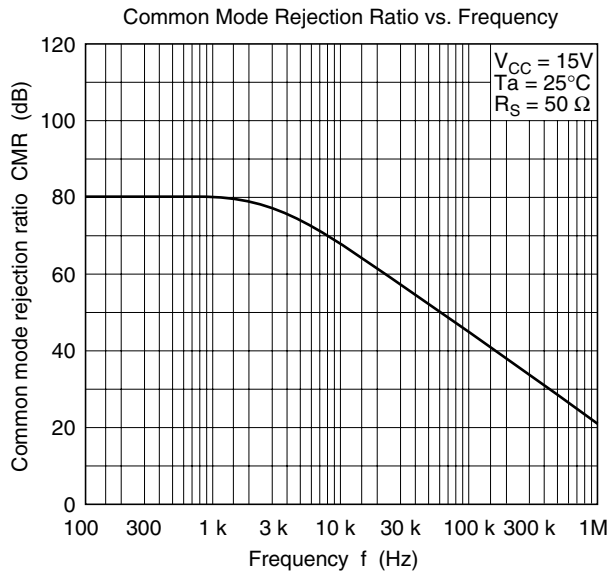
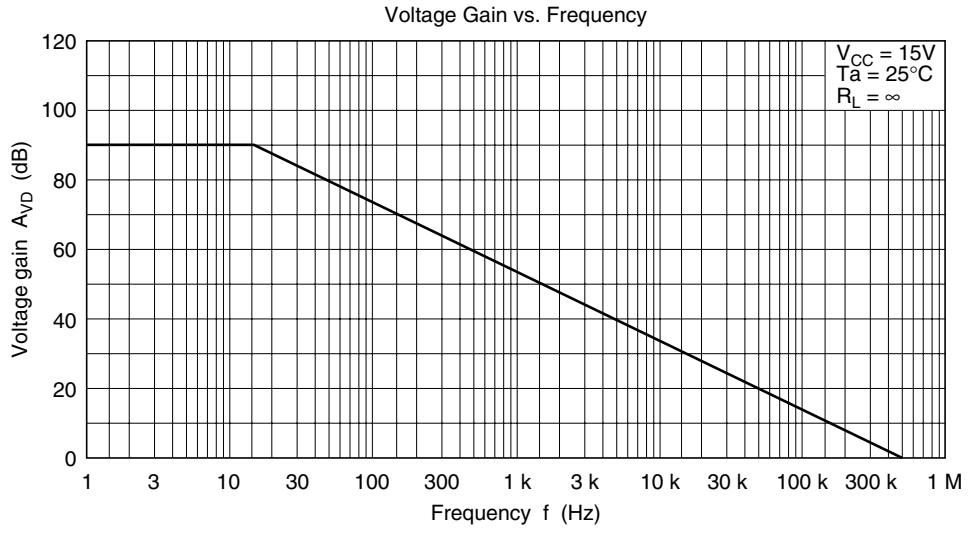

## Solder Mounting Method

1. Small and light surface-mount packages require special attentions on solder mounting.  
On solder mounting, pre-heating before soldering is needed.  
The following figure show an example of infrared rays reflow.  
The following figure show an example of infrared rays reflow.
2. The difference of thermal expansion coefficient between mounted substrates and IC leads may cause a failure like solder peeling or solder wet, and electrical characteristics may change by thermal stress.  
Therefore, mounting should be done after sufficient confirmation for especially in case of ceramic substrates.

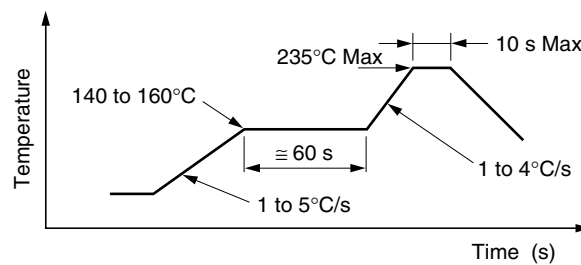

**Figure 1 An Example of Infrared Rays Reflow Conditions**

Package Dimensions

Unit: mm

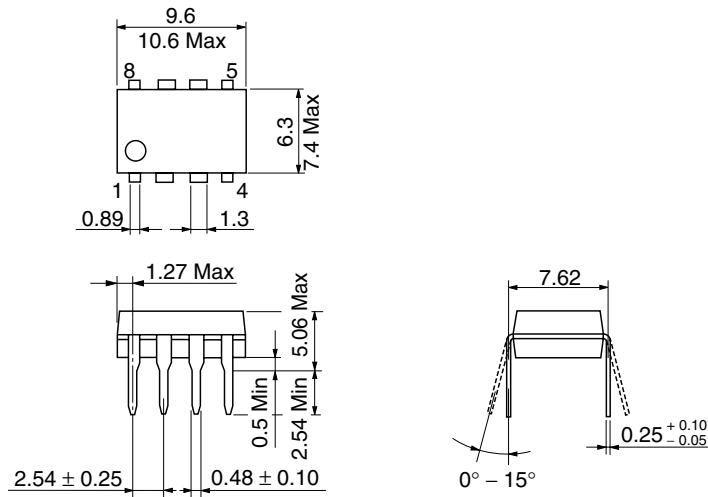

Unit: mm

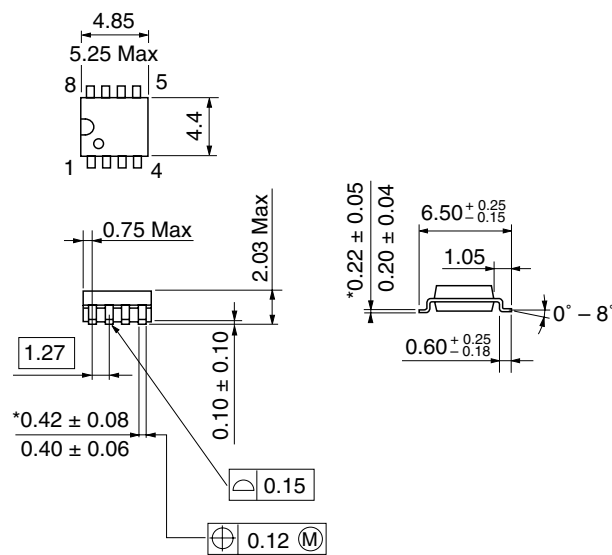

以上信息仅供参考. 如需帮助联系客服人员. 谢谢 XINLUDA



## X-ON Electronics

Largest Supplier of Electrical and Electronic Components

*Click to view similar products for [Operational Amplifiers - Op Amps](#) category:*

*Click to view products by [XINLUDA](#) manufacturer:*

Other Similar products are found below :

[OPA2991IDSGR](#) [OPA607IDCKT](#) [007614D](#) [633773R](#) [635798C](#) [635801A](#) [702115D](#) [709228FB](#) [741528D](#) [NCV33072ADR2G](#)  
[SC2902DTBR2G](#) [SC2903DR2G](#) [SC2903VDR2G](#) [LM258AYDT](#) [LM358SNG](#) [430227FB](#) [430228DB](#) [460932C](#) [AZV831KTR-G1](#) [409256CB](#)  
[430232AB](#) [LM2904DR2GH](#) [LM358YDT](#) [LT1678IS8](#) [042225DB](#) [058184EB](#) [070530X](#) [SC224DR2G](#) [SC239DR2G](#) [SC2902DG](#)  
[SCYA5230DR2G](#) [714228XB](#) [714846BB](#) [873836HB](#) [MIC918YC5-TR](#) [TS912BIYDT](#) [NCS2004MUTAG](#) [NCV33202DMR2G](#)  
[M38510/13101BPA](#) [NTE925](#) [SC2904DR2G](#) [SC358DR2G](#) [LM358EDR2G](#) [AZV358MTR-G1](#) [AP4310AUMTR-AG1](#) [HA1630D02MMEL-E](#)  
[NJM358CG-TE2](#) [HA1630S01LPEL-E](#) [LM324AWPT](#) [HA1630Q06TELL-E](#)