

## 1. DESCRIPTION

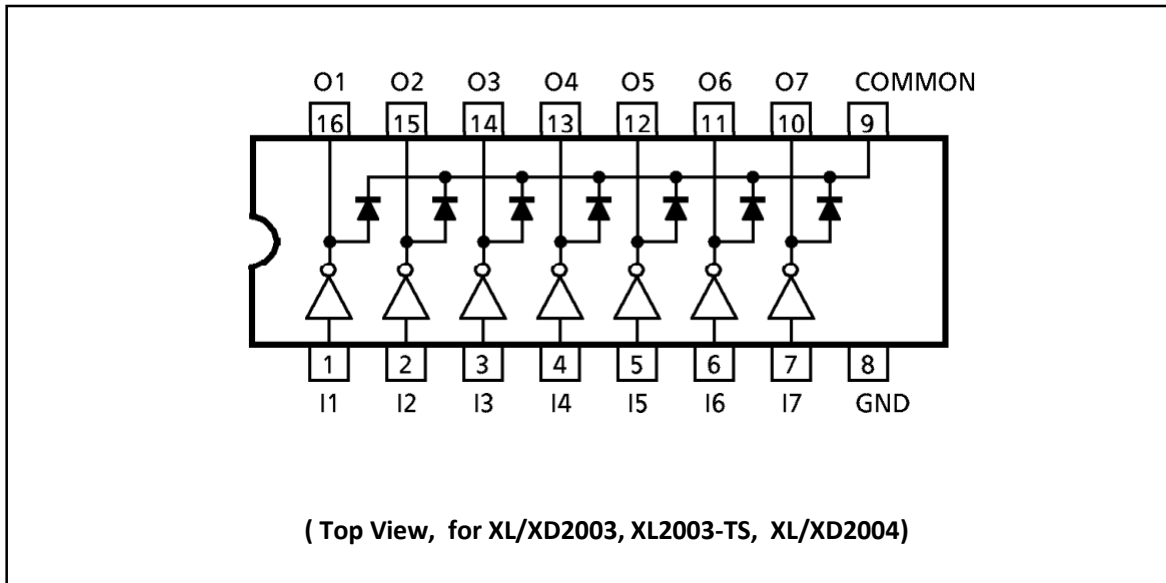
The 2003/2004 Series are high-voltage, high-current Darlington arrays each containing seven open collector Darlington pairs with common emitters. Each channel is rated at 500 mA. Suppression diodes are included for inductive load driving and the inputs are pinned opposite the outputs to simplify board layout.

The versions interface to all common logic families: XL/XD2003 (5 V TTL, CMOS), XL/XD2004 (6~15 V CMOS, PMOS). These versatile devices are useful for driving a wide range of loads including solenoids, relay DC motors, LED display filament lamps, thermal printheads etc.

## 2. FEATURES

- Rated Collector Output current (single output) up to 500 mA
- High- voltage outputs: 50V
- Integrated suppression diodes for inductive
- loads Inputs compatible with various types of logic
- Input pins placed opposite to output pins to simplify layout
- Package type include: SOP16、TSSOP16、DIP16

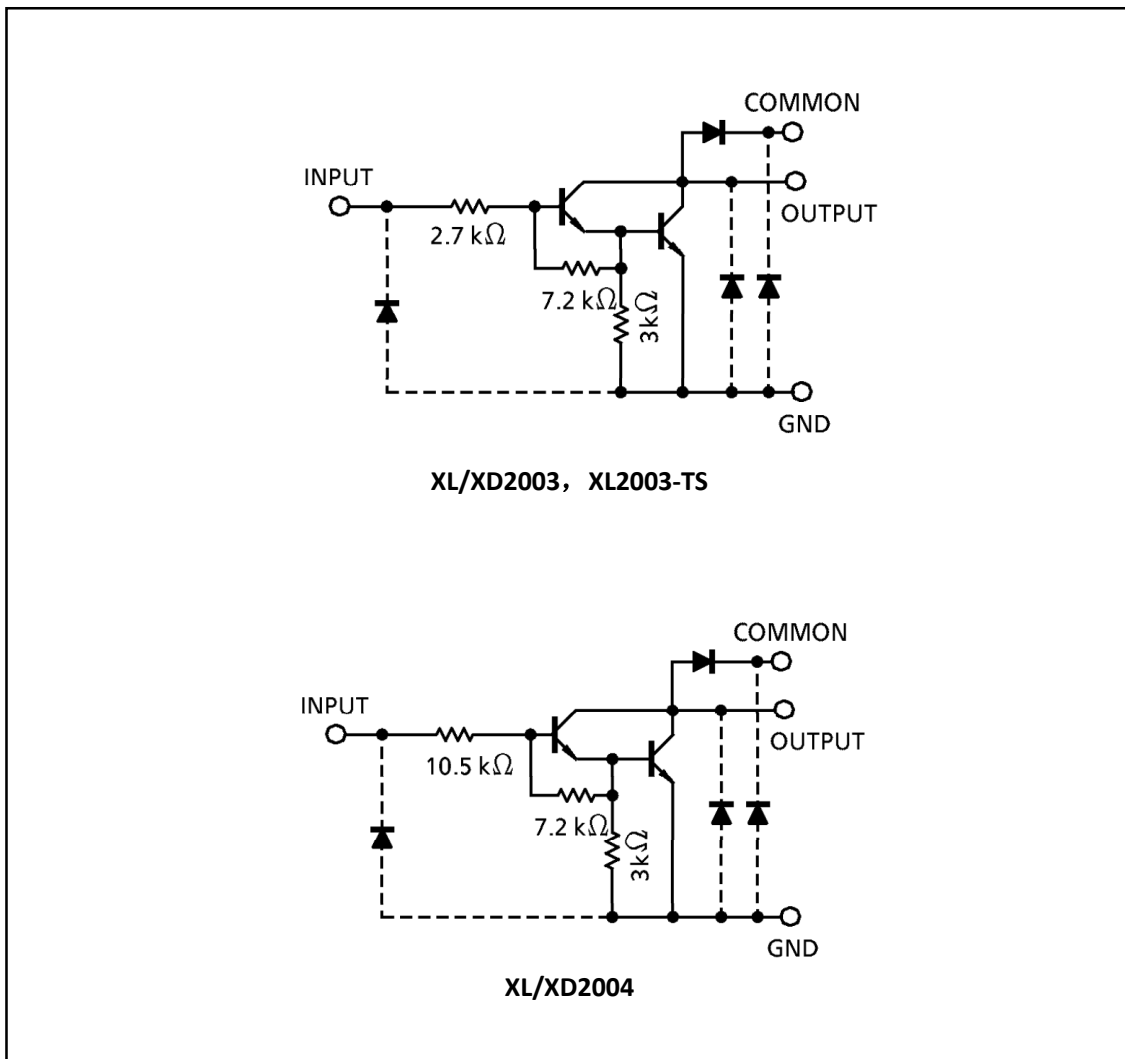
### 3. PIN CONFIGURATIONS AND FUNCTIONS



PIN		I/O	FUNCTION DESCRIPTIONS
NAME	NO.		
I1	1	I	Channel 1 through 7 Darlington base input
I2	2		
I3	3		
I4	4		
I5	5		
I6	6		
I7	7		
O1	16	O	Channel 1 through 7 Darlington collector output
O2	15		
O3	14		
O4	13		
O5	12		
O6	11		
O7	10		
COMMON	9	—	Common cathode node for flyback diodes (required for inductive loads)
GND	8	—	Common emitter shared by all channels (typically tied to ground)

( Note: I = Input, O = Output )

#### 4. SCHEMATICS (EACH DRIVER)



( Note: The input and output parasitic diodes can not be used as clamp diodes. )

TYPE	INPUT BASE RESISTOR	DESIGNATION
XL/XD2003, XL2003-TS	2.7 kΩ	TTL, 5 V CMOS
XL/XD2004	10.5 kΩ	6~15V PMOS, CMOS

## 5. SPECIFICATIONS

### 5.1. Absolute Maximum Ratings

**Table 1. Absolute maximum ratings**

Symbol	Parameter	Value	Unit
V <sub>O</sub>	Collector-emitter output voltage	50	V
V <sub>I</sub>	Input voltage	30	V
I <sub>C</sub>	Continuous collector current	500	mA
I <sub>B</sub>	Continuous base current	25	mA
I <sub>F</sub>	Clamping diode continuous current	350	mA
V <sub>R</sub>	Clamping diode reverse voltage	50	V
T <sub>A</sub>	Operating ambient temperature range	-20 to 85	°C
T <sub>STG</sub>	Storage temperature range	-40 to 125	°C
T <sub>J</sub>	Junction temperature	150	°C
ESD	Electrostatic discharge rating - HBM	0.8	kV

**Table 2. Thermal data**

Symbol	Parameter	DIP-16	SO-16	TSSOP16	Unit
R <sub>thJA</sub>	Thermal resistance junction-ambient, Max.	78	69.3	105.7	°C/W
R <sub>thJC</sub>	Thermal resistance junction-case (top), Max.		29	36.9	°C/W
R <sub>thJB</sub>	Thermal resistance junction-board, Max.		37.5	72.8	°C/W

*Note: Maximum power dissipation is a function of T<sub>J(max)</sub>, R<sub>thJA</sub> and T<sub>A</sub>. The maximum allowable power dissipation at any allowable ambient temperature is P<sub>D</sub> = (T<sub>J(max)</sub> - T<sub>A</sub>) / R<sub>thJA</sub>. Operating at the absolute maximum T<sub>J</sub> of +150°C can affect reliability.*

**5.2 Electrical characteristic** ( TA = 25 °C unless otherwise specified )

Symbol	Parameter	Test condition	Min.	Typ.	Max.	Unit
I <sub>CEX</sub>	Output leakage current	V <sub>CE</sub> = 50 V, (Figure 3)			60	μA
		T <sub>A</sub> = -20 °C, V <sub>CE</sub> = 50 V (Figure 3)			95	
		T <sub>A</sub> = 85 °C, V <sub>CE</sub> = 50 V, V <sub>I</sub> = 5 V (Figure 4)			600	
		T <sub>A</sub> = -20 °C, V <sub>CE</sub> = 50 V, V <sub>I</sub> = 5V (Figure 4)			500	
V <sub>CE(SAT)</sub>	Collector-emitter saturation voltage (Figure 5)	I <sub>C</sub> = 100 mA, I <sub>B</sub> = 250 μA		0.8	1.2	V
		I <sub>C</sub> = 200 mA, I <sub>B</sub> = 350 μA		1.2	1.4	
		I <sub>C</sub> = 350 mA, I <sub>B</sub> = 500 μA		1.4	1.8	
		for XL/XD2003, V <sub>I</sub> = 3.85 V		0.95	1.5	
		for XL/XD2004, V <sub>I</sub> = 5 V V <sub>I</sub> = 12 V		0.35 1.1	0.7 1.6	
I <sub>I(OFF)</sub>	Input current (Figure 7)	T <sub>A</sub> = 85 °C, I <sub>C</sub> = 500 μA		70		μA
V <sub>I(ON)</sub>	Input voltage (Figure 8)	for XL/XD2003, XL2003-TS				
		I <sub>C</sub> = 200 mA			2.7	V
		I <sub>C</sub> = 250 mA			2.9	V
		I <sub>C</sub> = 300 mA			3.2	V
		for XL/XD2004				
		I <sub>C</sub> = 125 mA			5	V
		I <sub>C</sub> = 200 mA			6	V
I <sub>C</sub> = 275 mA			7	V		
I <sub>C</sub> = 350 mA			8	V		
h <sub>FE</sub>	DC Forward current gain (Figure 5)	V <sub>CE</sub> = 2 V, I <sub>C</sub> = 350 mA	1000			
C <sub>I</sub>	Input capacitance			15	30	pF
t <sub>PLH</sub>	Turn-on delay time	0.5 V <sub>I</sub> to 0.5 V <sub>O</sub>		0.25	1.2	μs
t <sub>PHL</sub>	Turn-off delay time	0.5 V <sub>I</sub> to 0.5 V <sub>O</sub>		0.25	1.2	μs
I <sub>R</sub>	Clamp diode leakage current (Figure 9)	V <sub>R</sub> = 50 V			70	μA
		T <sub>A</sub> = 85 °C, V <sub>R</sub> = 50 V			120	
V <sub>F</sub>	Clamp diode forward voltage (Figure 10)	I <sub>F</sub> = 350 mA		1.8	2.3	V

5.3 Measurement circuits

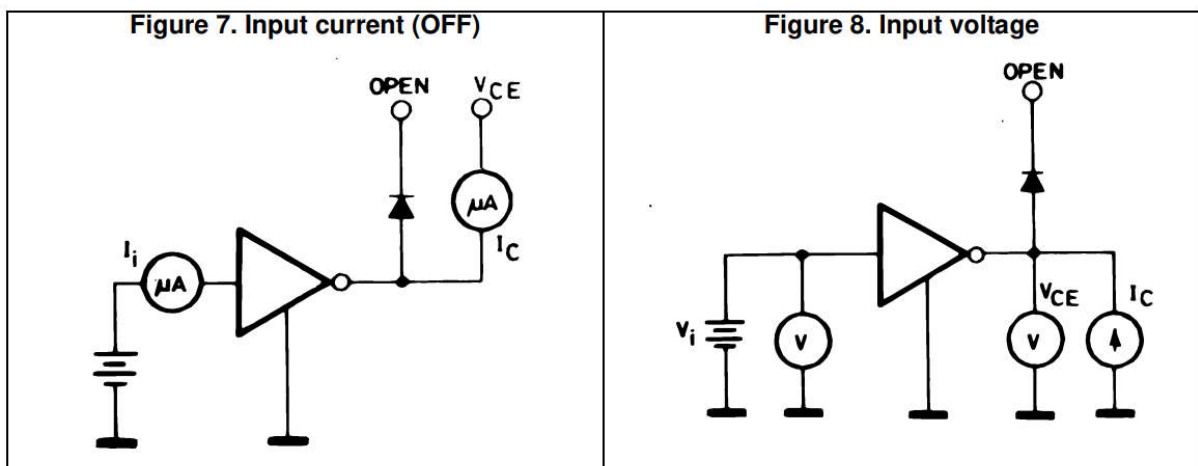
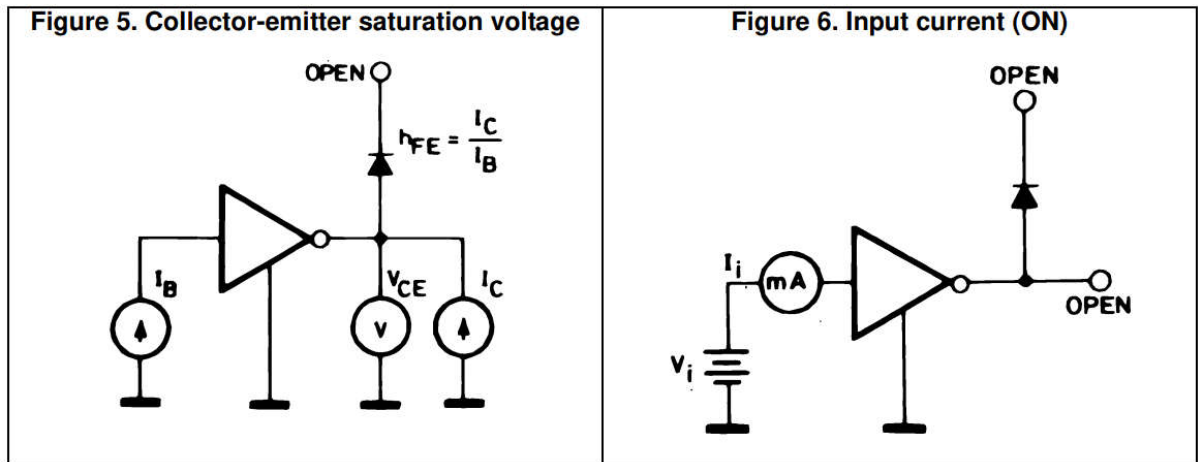
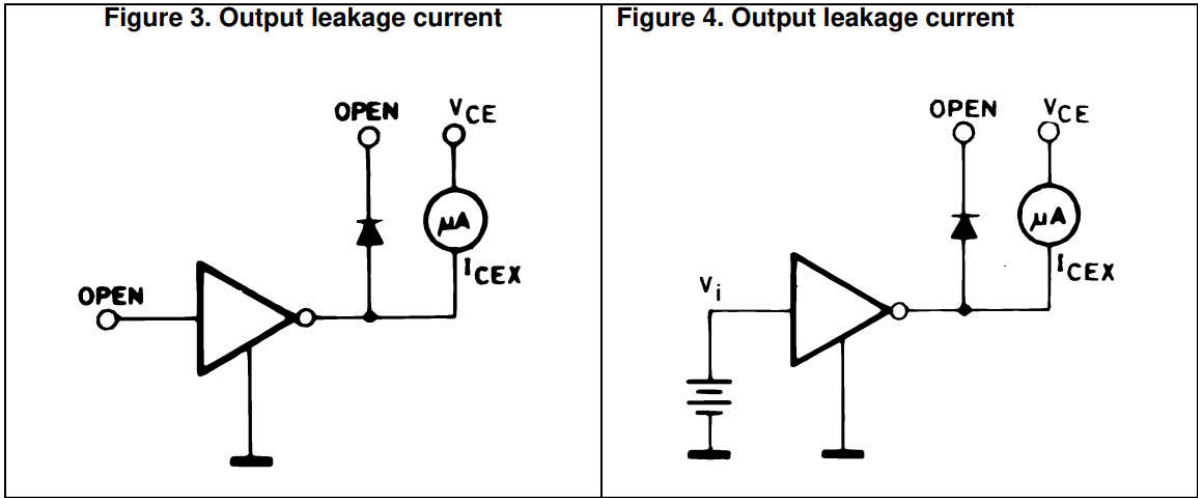


Figure 9. Clamp diode leakage current

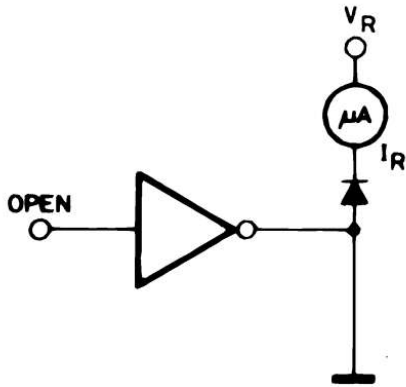
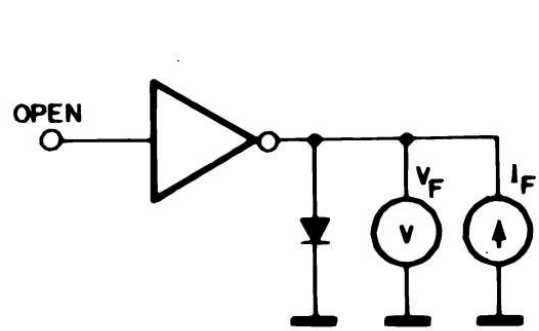
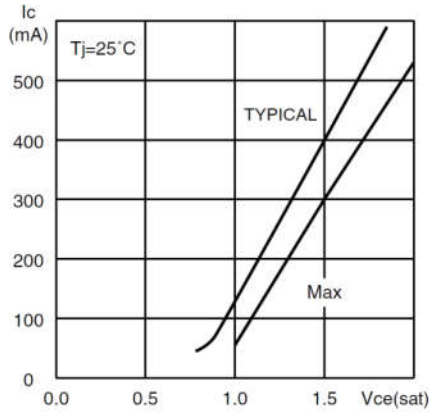


Figure 10. Clamp diode forward voltage

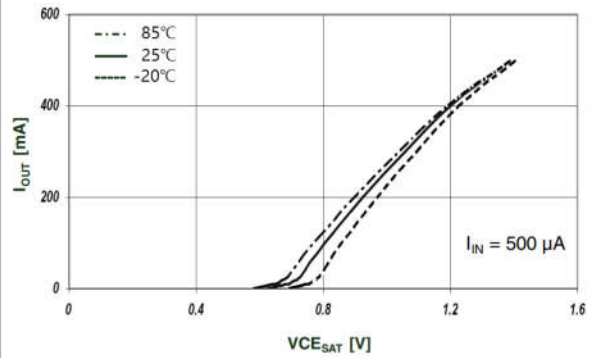


## 6. TYPICAL PERFORMANCE CHARACTERISTICS

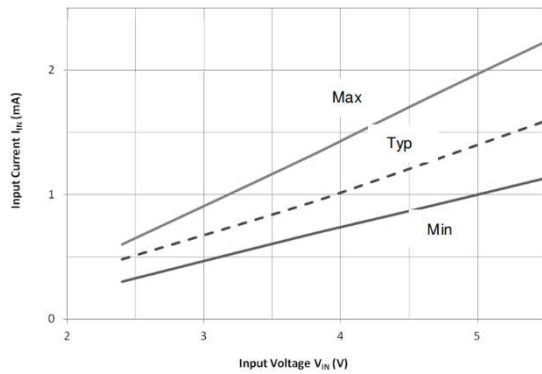
**Figure 11. Collector current vs. saturation voltage ( $T_J = 25^\circ\text{C}$ )**



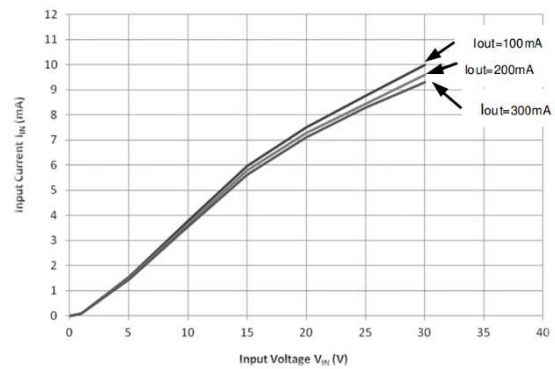
**Figure 12. Collector current vs. saturation voltage**



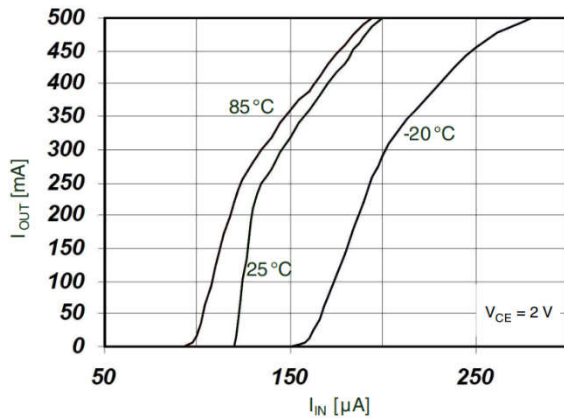
**Figure 13. Input current vs. input voltage**



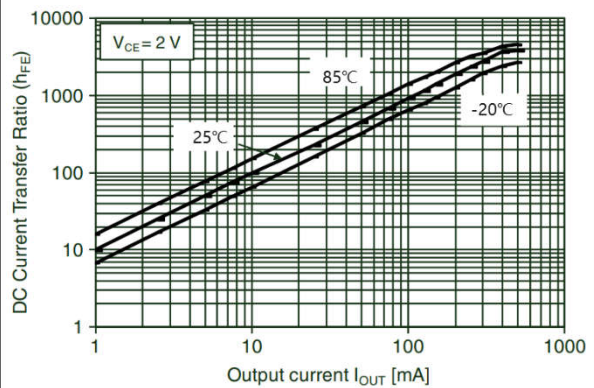
**Figure 14. Input current vs. input voltage ( $T_a = 25^\circ\text{C}$ )**



**Figure 15. Collector current vs. input current**

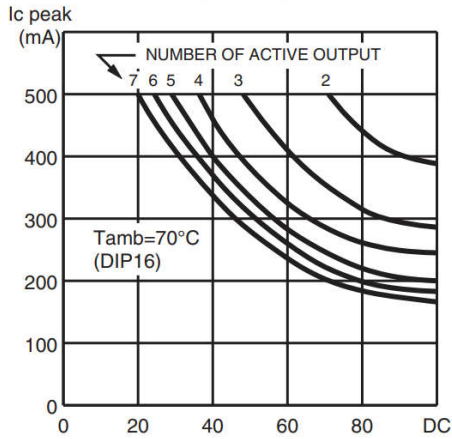


**Figure 16.  $h_{FE}$  vs. output current**

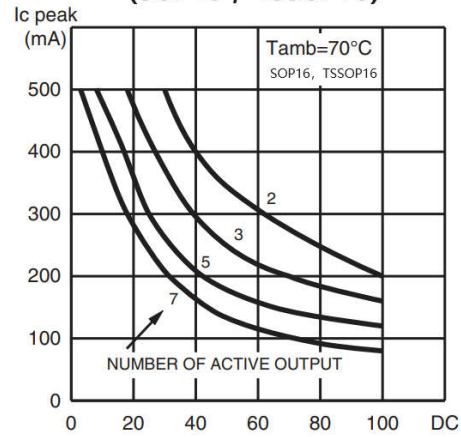




**Figure 17. Peak collector current vs. duty cycle (DIP16)**



**Figure 18. Peak collector current vs. duty cycle (SOP16, TSSOP16)**

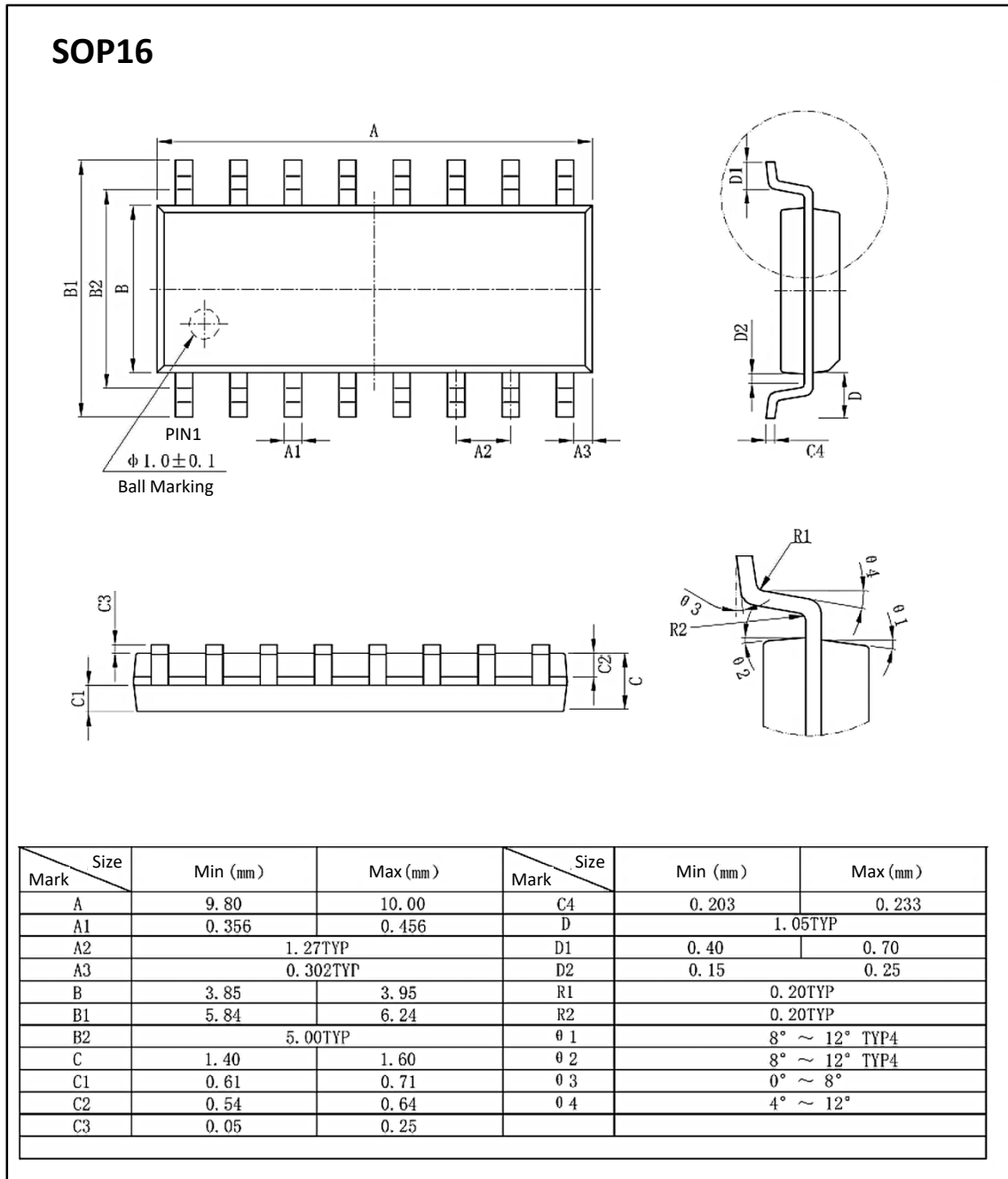


## 7. ORDERING INFORMATION

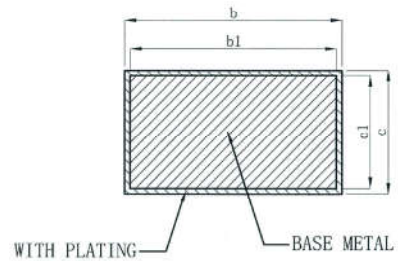
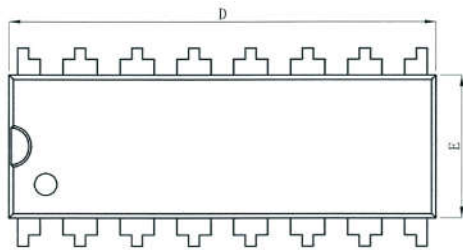
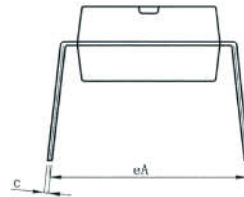
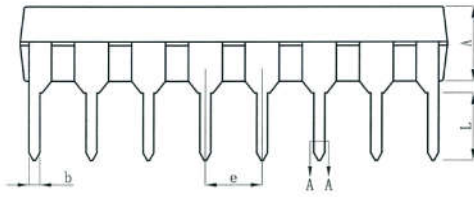
### Ordering Information

Part Number	Device Marking	Package Type	Body size (mm)	Temperature (°C)	MSL	Transport Media	Package Quantity
XL2003-TS	XL2003-TS	TSSOP16	5.00 * 3.90	- 20 to 85	MSL3	T&R	2500
XL2003	XL2003	SOP16	10.00 * 3.95	- 20 to 85	MSL3	T&R	2500
XD2003	XD2003	DIP16	19.05 * 6.35	- 20 to 85	MSL3	Tube 25	1000
XL2004	XL2004	SOP16	10.00 * 3.95	- 20 to 85	MSL3	T&R	2500
XD2004	XD2004	DIP16	19.05 * 6.35	- 20 to 85	MSL3	Tube 25	1000

## 8. DIMENSIONAL DRAWINGS



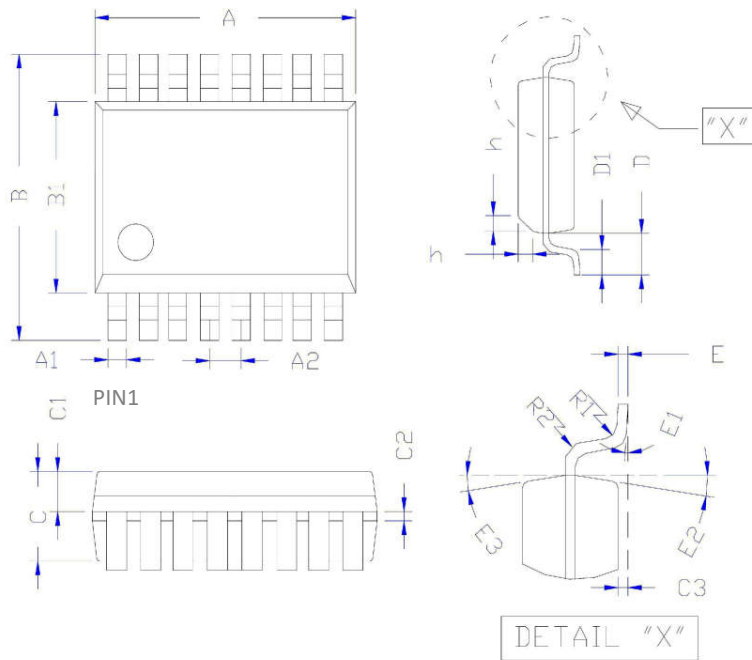
## DIP16



PIN1

symbol	millimeter		
	Min	Nom	Max
A	3.20	3.30	3.40
b	0.44	---	0.53
b1	0.43	0.46	0.49
c	0.25	---	0.30
c1	0.24	0.25	0.26
D	18.95	19.05	19.15
E	6.25	6.35	6.45
e	2.54BSC		
eA	8.30	8.80	9.30
L	3.00	---	---

## TSSOP16



Symbol	Indicate	MIN	NOM	MAX
A	Overall length	4.95	5.00	5.05
A1	Foot width	0.20	0.22	0.24
A2	Foot spacing	0.60	0.65	0.70
B	Span	5.70	6.00	6.30
B1	Colloid width	3.80	3.90	4.00
C	Colloid thickness	0.95	1.00	1.05
C1	Thickness of upper colloid	0.40	0.41	0.42
C2		0.05	0.15	0.25
C3	Stand height	0.02	0.08	0.10
D	Fingle-sided Factory	0.85	1.05	1.25
D1	Foot length	0.40	0.65	0.85
E	Foot Thickness	0.15	0.20	0.25
E2	Foot Angle	0°		8°
h		0.30	0.40	0.50

[ if you need help contact customer service staff Xinluda reserves the right to change the above information without prior notice ]

## X-ON Electronics

Largest Supplier of Electrical and Electronic Components

*Click to view similar products for [Darlington Transistors](#) category:*

*Click to view products by [XINLUDA](#) manufacturer:*

Other Similar products are found below :

[BDV64B](#) [SBSP52T1G](#) [Jantx2N6058](#) [LB1205-L-E](#) [2N6053](#) [MPSA63](#) [NTE256](#) [TIP120](#) [MJ11028](#) [TIP127](#) [Jantx2N6352](#) [NJVBUB323ZT4G](#)  
[ULN2003](#) [ULN2803QN](#) [GN2003B](#) [MJD127T4G-JSM](#) [KID65004AF-EL/P](#) [ULN2803](#) [ULN2803CDWR](#) [HT62783ARTZ](#) [ULN2803A](#)  
[GN2803A](#) [MC1413BM/TR](#) [ULN2003AN](#) [ULN2003LVM/TR](#) [HT1413ARZ](#) [ULN2803A](#) [ULN2003](#) [ULN2803](#) [IK62783N](#) [IK62083N](#)  
[ULN2003AL](#) [MMBTA63](#) [ULN2001D](#) [ULN2004N](#) [ULN2003A](#) [TIP127-JSM](#) [2N6052](#) [2SB1560](#) [2SB852KT146B](#) [2SD2560](#) [TIP112TU](#)  
[BCV27](#) [MMBTA13-TP](#) [MMBTA14-TP](#) [MMSTA28T146](#) [BSP50H6327XTSA1](#) [NTE2557](#) [NJVNJD35N04T4G](#) [MPSA29-D26Z](#)