

1. DESCRIPTION

The XZ298N/XL298P is an integrated monolithic circuit in a 15-lead ZIP and HSOP20 packages. It is a high voltage, high current dual full-bridge driver designed to accept standard TTL logic levels and drive inductive loads such as relays, solenoids, DC and stepping motors. Two enable inputs are provided to enable or disable the device independently of the input signals. The emitters of the lower transistors of each bridge are connected together and the corresponding external terminal can be used for the con-lower voltage.

2. FEATURES

- OPERATING SUPPLY VOLTAGE UP TO 42 V
- TOTAL DC CURRENT UP TO 3.5 A
- LOW SATURATION VOLTAGE
- OVERTEMPERATURE PROTECTION
- LOGICAL "0" INPUT VOLTAGE UP TO 1.5 V (HIGH NOISE IMMUNITY)

3. PIN CONFIGURATIONS AND FUNCTIONS

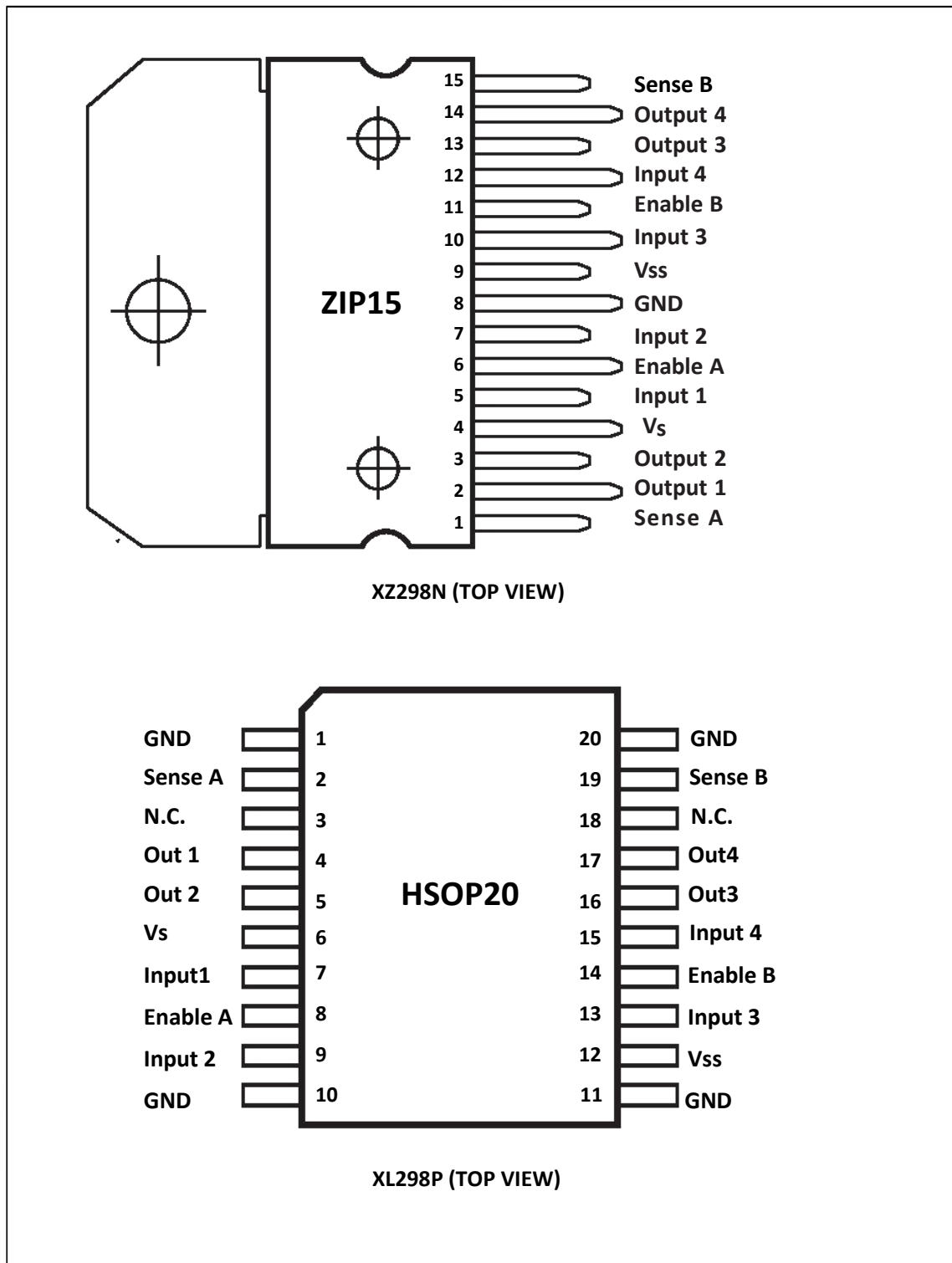

Figure 1. PIN CONFIGURATIONS

Table 1. Pin Functions

ZIP15	HSOP20	Name	Function
1;15	2;19	Sense A; Sense B	Between this pin and ground is connected the sense resistor to control the current of the load.
2;3	4;5	Out 1; Out 2	Outputs of the Bridge A; the current that flows through the load connected between these two pins is monitored at pin 1.
4	6	Vs	Supply Voltage for the Power Output Stages. A non-inductive 100nF capacitor must be connected between this pin and ground.
5;7	7;9	Input 1; Input 2	TTL Compatible Inputs of the Bridge A.
6;11	8;14	Enable A; Enable B	TTL Compatible Enable Input: the L state disables the bridge A (enable A) and/or the bridge B (enable B).
8	1,10,11,20	GND	Ground.
9	12	Vss	Supply Voltage for the Logic Blocks. A100nF capacitor must be connected between this pin and ground.
10;12	13;15	Input 3; Input 4	TTL Compatible Inputs of the Bridge B.
13;14	16;17	Out 3; Out 4	Outputs of the Bridge B. The current that flows through the load connected between these two pins is monitored at pin 15.
-	3;18	N.C.	Not Connected

4. BLOCK DIAGRAM

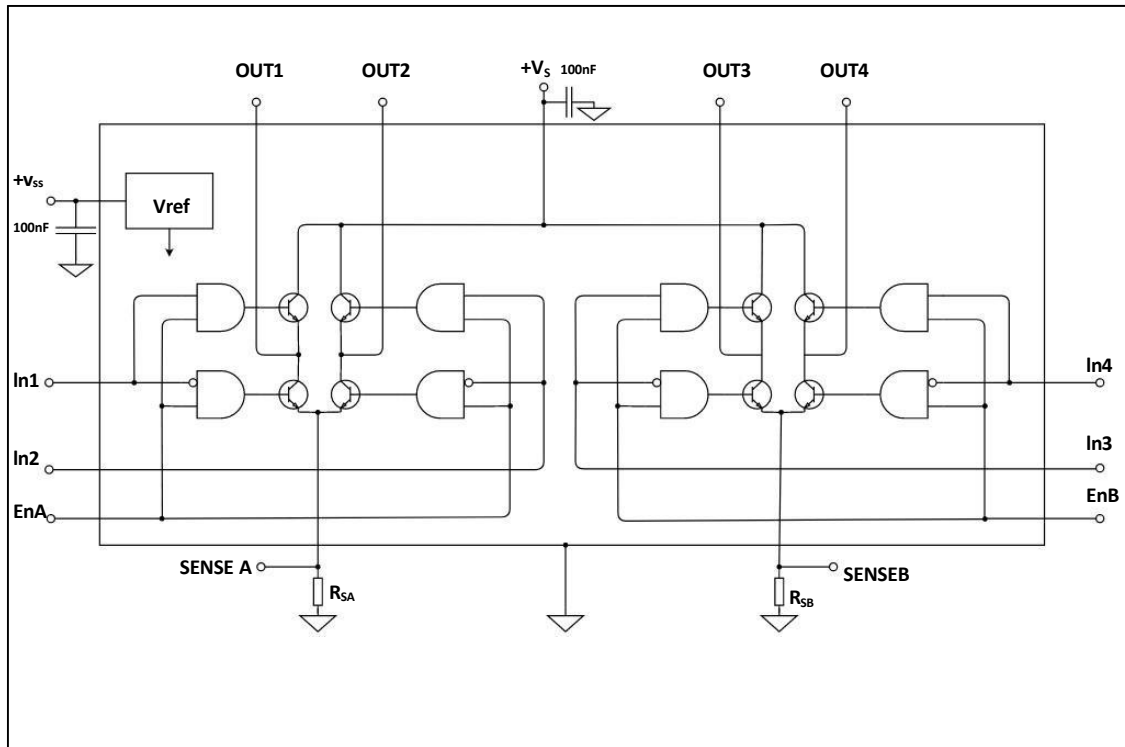

Figure 2. Block Diagram

5. SPECIFICATIONS

5.1. Absolute Maximum Ratings

Symbol	Parameter	Value	Unit
V _s	Power Supply	48	V
V _{SS}	Logic Supply Voltage	7	V
V _I ,V _{en}	Input and Enable Voltage	-0.3 to 7	V
I _o	Peak Output Current (each Channel) – Non Repetitive (t = 100μs) – Repetitive (80% on –20% off; ton = 10ms) – DC Operation	3	A
		2.5	A
		2	A
V _{sens}	Sensing Voltage	-1 to 2.3	V
P _{tot}	Total Power Dissipation (T _{case} = 75 °C)	25	W
T _{op}	Junction Operating Temperature	-25 to 120	°C
T _{stg} , T _j	Storage and Junction Temperature	-40 to 130	°C

5.2. Thermal Data

Symbol	Parameter		HSOP20	ZIP15	Unit
R _{thj-case}	Thermal Resistance Junction-case	Max.	—	5	°C/W
R _{thj-amb}	Thermal Resistance Junction-ambient	Max.	15 ^[1]	37	°C/W

[1] Mounted on aluminum substrat

5.3. Electrical Characteristics (V_S = 36V; V_{SS} = 5V, T_j = 25 °C; unless otherwise specified)

Symbol	Parameter	Test Conditions	Min.	Typ.	Max.	Unit
	Supply Voltage (pin 4)	Operative Condition	V _{IH} +2.5		42	V
V _{SS}	Logic Supply Voltage (pin 9)		4.5	5	7	V
I _s	Quiescent Supply Current (pin 4)	V _{en} = H; I _L = 0V _I = L V _I = H		13	22	mA
				50	70	mA
		V _{en} = LV _I = X			4	mA
I _{SS}	Quiescent Current from V _{SS} (pin 9)	V _{en} = H; I _L = 0V _I = L V _I = H		24	36	mA
				7	12	mA
		V _{en} = L V _I = X			6	mA
V _{IL}	Input Low Voltage (pins 5, 7, 10, 12)		-0.3		1.5	V
V _{IH}	Input High Voltage (pins 5, 7, 10, 12)		2.3		V _{SS}	V
I _{IL}	Low Voltage Input Current (pins 5, 7, 10, 12)	V _I = L			-10	μA
I _{IH}	High Voltage Input Current (pins 5, 7, 10, 12)	V _I = H V _{SS} = -0.6V		30	100	μA
V _{en} = L	Enable Low Voltage (pins 6, 11)		-0.3		1.5	V
V _{en} = H	Enable High Voltage (pins 6, 11)		2.3		V _{SS}	V
I _{en} = L	Low Voltage Enable Current (pins 6, 11)	V _{en} = L			-10	μA
I _{en} = H	High Voltage Enable Current (pins 6, 11)	V _{en} = H V _{SS} = -0.6V		30	100	μA

Electrical Characteristics (continued)

Symbol	Parameter	Test Conditions	Min.	Typ.	Max.	Unit
V _{CEsat(H)}	Source Saturation Voltage	I _L = 1A	0.95	1.35	1.7	V
		I _L = 2A		2	2.7	V
V _{CEsat(L)}	Sink Saturation Voltage	I _L = 1A (5)	0.85	1.2	1.6	V
		I _L = 2A (5)		1.7	2.3	V
V _{CEsat}	Total Drop	I _L = 1A (5)	1.80		3.2	V
		I _L = 2A (5)			4.9	V
V _{sens}	Sensing Voltage (pins 1, 15)		-1 (1)		2	V
T ₁ (V _i)	Source Current Turn-off Delay	0.5 V _i to 0.9 I _L (2); (4)		1.5		μs
T ₂ (V _i)	Source Current Fall Time	0.9 I _L to 0.1 I _L (2); (4)		0.2		μs
T ₃ (V _i)	Source Current Turn-on Delay	0.5 V _i to 0.1 I _L (2); (4)		2		μs
T ₄ (V _i)	Source Current Rise Time	0.1 I _L to 0.9 I _L (2); (4)		0.7		μs
T ₅ (V _i)	Sink Current Turn-off Delay	0.5 V _i to 0.9 I _L (3); (4)		0.7		μs
T ₆ (V _i)	Sink Current Fall Time	0.9 I _L to 0.1 I _L (3); (4)		0.25		μs
T ₇ (V _i)	Sink Current Turn-on Delay	0.5 V _i to 0.9 I _L (3); (4)		1.6		μs
T ₈ (V _i)	Sink Current Rise Time	0.1 I _L to 0.9 I _L (3); (4)		0.2		μs
f _c (V _i)	Commutation Frequency	I _L = 2A		25	40	μs
T ₁ (V _{en})	Source Current Turn-off Delay	0.5 V _{en} to 0.9 I _L (2); (4)		3		μs
T ₂ (V _{en})	Source Current Fall Time	0.9 I _L to 0.1 I _L (2); (4)		1		μs
T ₃ (V _{en})	Source Current Turn-on Delay	0.5 V _{en} to 0.1 I _L (2); (4)		0.3		μs
T ₄ (V _{en})	Source Current Rise Time	0.1 I _L to 0.9 I _L (2); (4)		0.4		μs
T ₅ (V _{en})	Sink Current Turn-off Delay	0.5 V _{en} to 0.9 I _L (3); (4)		2.2		μs
T ₆ (V _{en})	Sink Current Fall Time	0.9 I _L to 0.1 I _L (3); (4)		0.35		μs
T ₇ (V _{en})	Sink Current Turn-on Delay	0.5 V _{en} to 0.9 I _L (3); (4)		0.25		μs
T ₈ (V _{en})	Sink Current Rise Time	0.1 I _L to 0.9 I _L (3); (4)		0.1		μs

- [1] Sensing voltage can be -1 V for t ≤ 50 μsec; in steady state V_{sens} min ≥ -0.5 V.
- [2] See fig. 2.
- [3] See fig. 4.
- [4] The load must be a pure resist

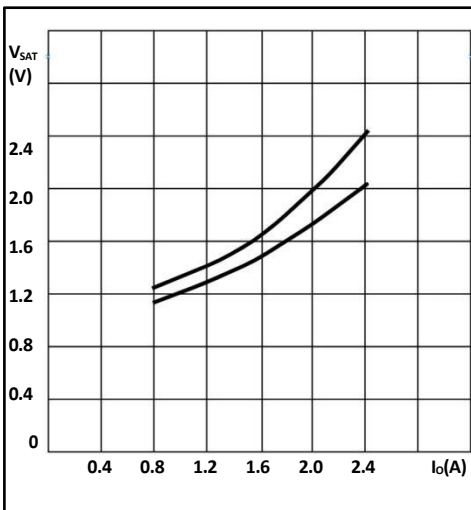
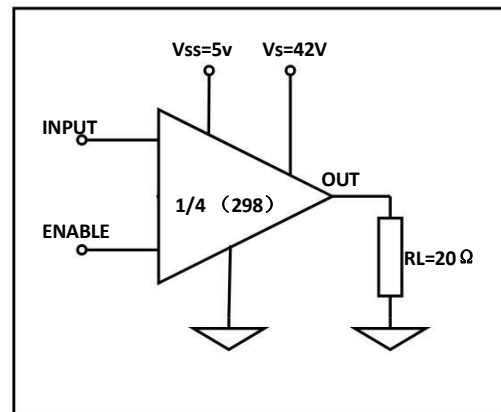

Figure 3 : Typical Saturation Voltages. Output Current.



Note : For INPUT Switching, set EN = H
For ENABLE Switching, set IN = L

Figure 4 : Switching Times Test Circuits.

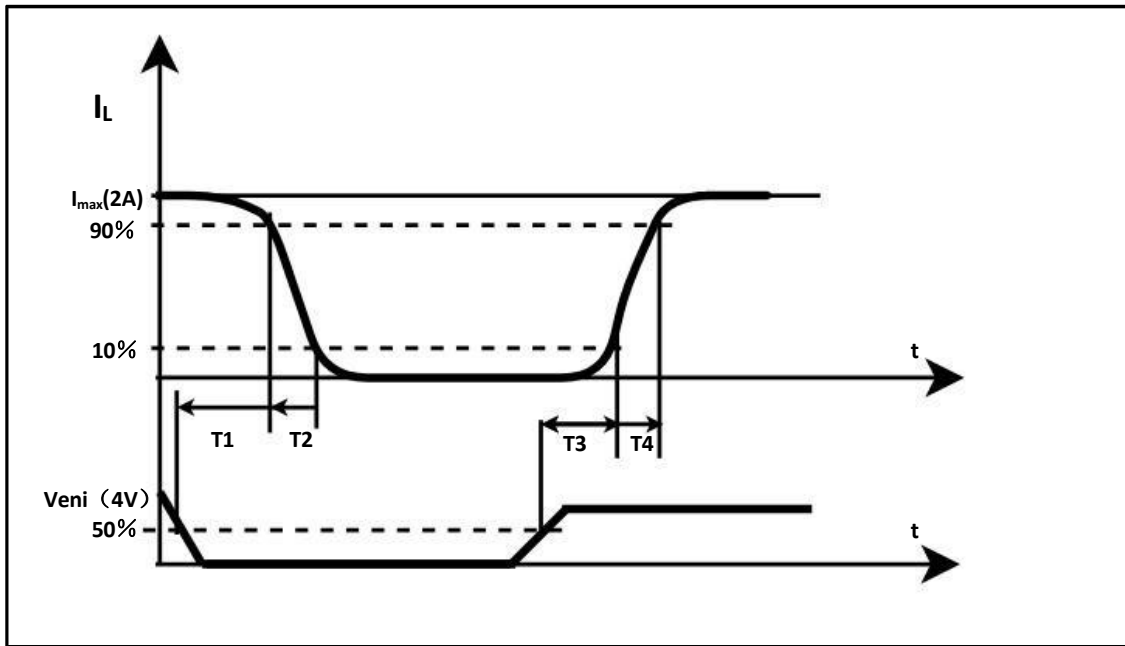
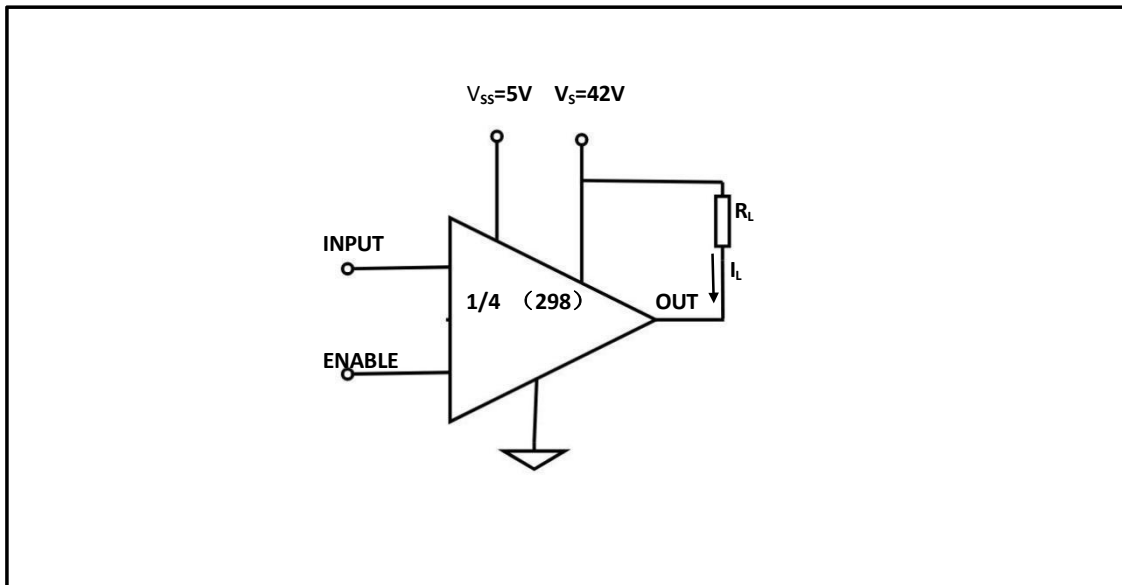

Figure 5 : Source Current Delay Times vs. Input or Enable Switching.



Note : For INPUT Switching, set EN = H
 For ENABLE Switching, set IN = H

Figure 6 : Switching Times Test Circuits.

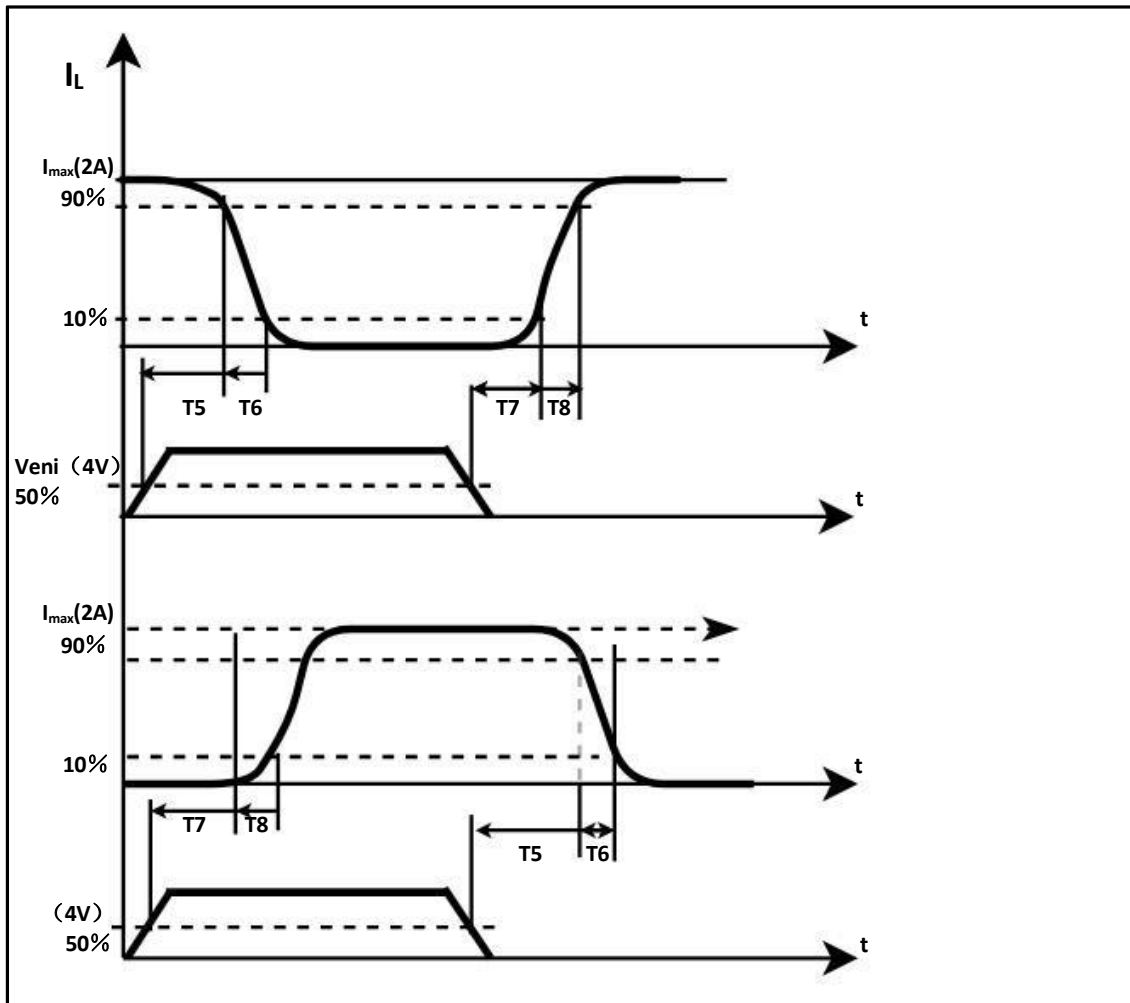

Figure 7 : Sink Current Delay Times vs. Input 0 V Enable Switching.

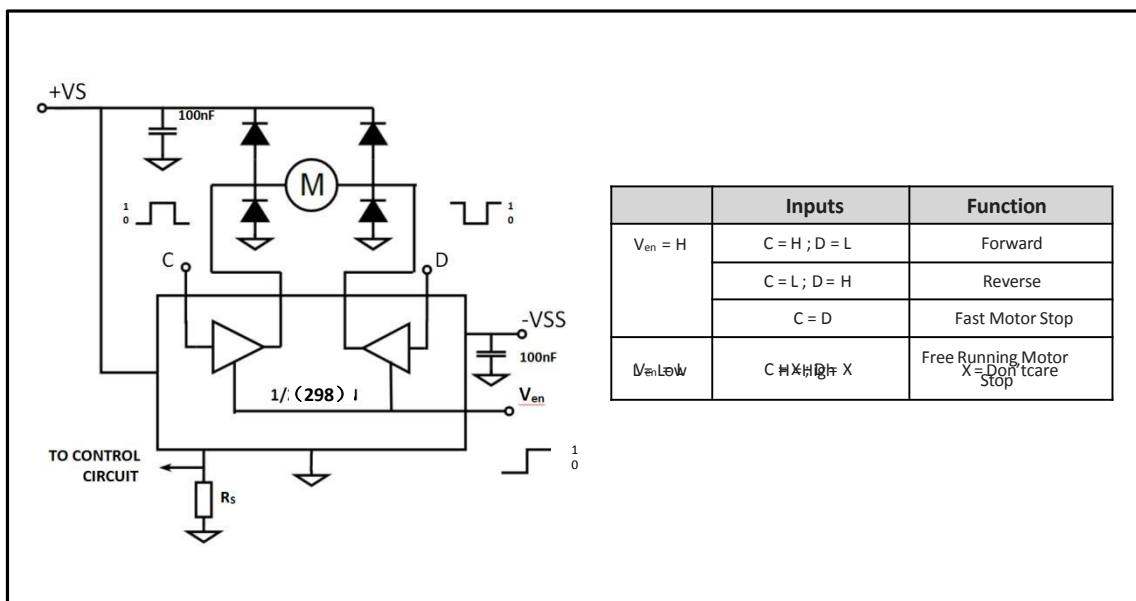

Figure 8 : Bidirectional DC Motor Control.

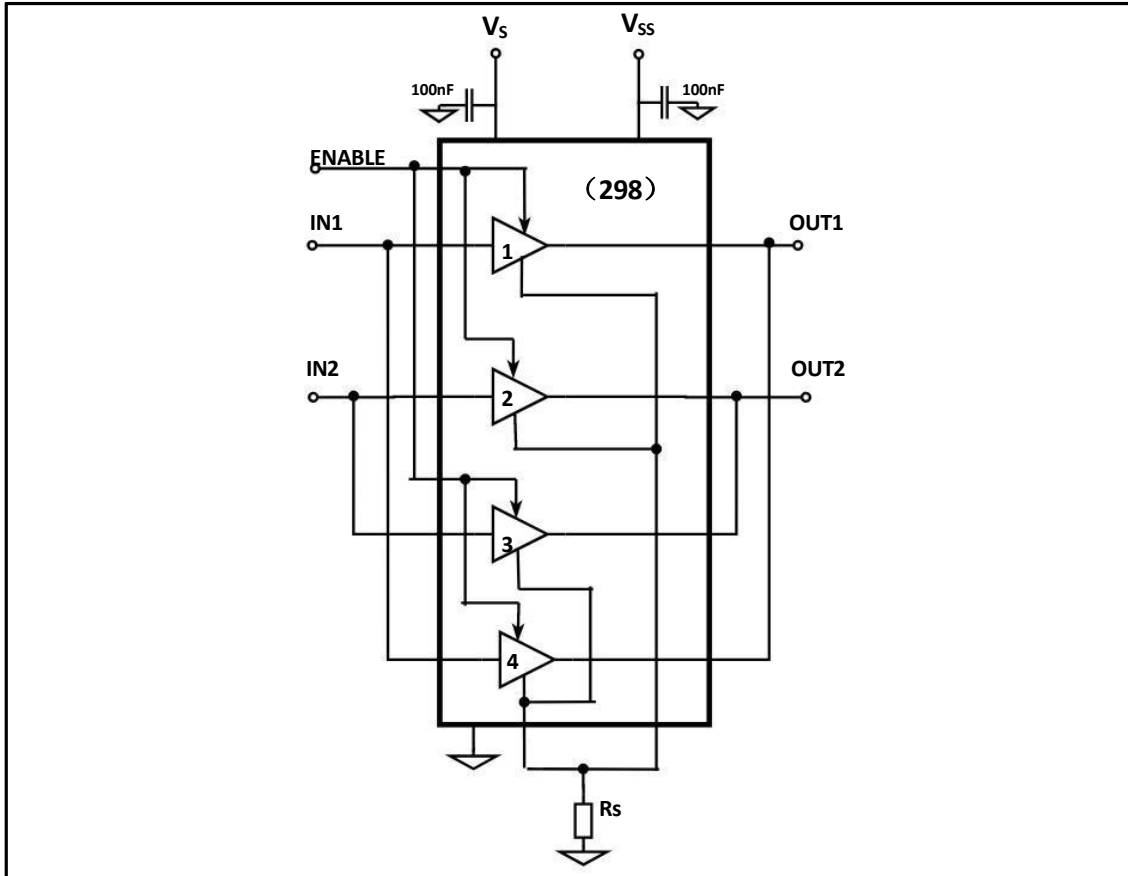

Figure 9 : For higher currents, outputs can be paralleled. Take care to parallel channel 1 with channel 4 and channel 2 with channel 3.

6. Application Information

6.1. POWER OUTPUT STAGE

The XZ298N/XL298P integrates two power outputs stages (A; B). The power output stage is a bridge configuration and its outputs can drive an inductive load in common or differential mode, depending on the state of the inputs. The current that flows through the load comes out from the bridge at the sense output : an external resistor (RSA ; RSB.) allows to detect the intensity of this current.

6.2. INPUT STAGE

Each bridge is driven by means of four gates the input of which are In1 ; In2 ; EnA and In3 ; In4 ; EnB. The In inputs set the bridge state when The En input is high; a low state of the En input inhibits the bridge. All the inputs are TTL compatible.

6.3. SUGGESTIONS

A non inductive capacitor, usually of 100 nF, must be foreseen between both Vs and Vss, to ground, as near as possible to GND pin. When the large capacitor of the power supply is too far from the IC, a second smaller one must be foreseen near the XZ298N/XL298P.

The sense resistor, not of a wire wound type, must be grounded near the negative pole of Vs that must be near the GND pin of the I.C.

Each input must be connected to the source of the driving signals by means of a very short path.

Turn-On and Turn-Off : Before to Turn ON the Supply Voltage and before to Turn it OFF, the Enable input must be driven to the Low state.

6.4. APPLICATIONS

Fig 8 shows a bidirectional DC motor control Schematic Diagram for which only one bridge is needed. The external bridge of diodes D1 to D4 is made by four fast recovery elements ($t_{rr} \leq 200$ nsec) that must be chosen of a VF as low as possible at the worst case of the load current.

The sense output voltage can be used to control the current amplitude by chopping the inputs, or to provide over current protection by switching low the enable input.

The brake function (Fast motor stop) requires that the Absolute Maximum Rating of 2 Amps must never be overcome.

When the repetitive peak current needed from the load is higher than 2 Amps, a paralleled configuration can be chosen (See Fig.11).

An external bridge of diodes are required when inductive loads are driven and when the inputs of the IC are chopped; Schottky diodes would be preferred.

This solution can drive until 3 Amps in DC operation and until 3.5 Amps of a repetitive peak current.

On Fig 10 it is shown the driving of a two phase bipolar stepper motor ; the needed signals to drive the in- puts of the XZ298N/XL298P are generated, in this example, from the IC XD297.

Fig 11 shows an example of P.C.B. designed for the application of Fig 10.

Fig 12 shows a second two phase bipolar stepper motor control circuit where the current is controlled by the I.C. L6506.

This circuit drives bipolar stepper motors with winding currents up to 2 A. The diodes are fast 2 A types.

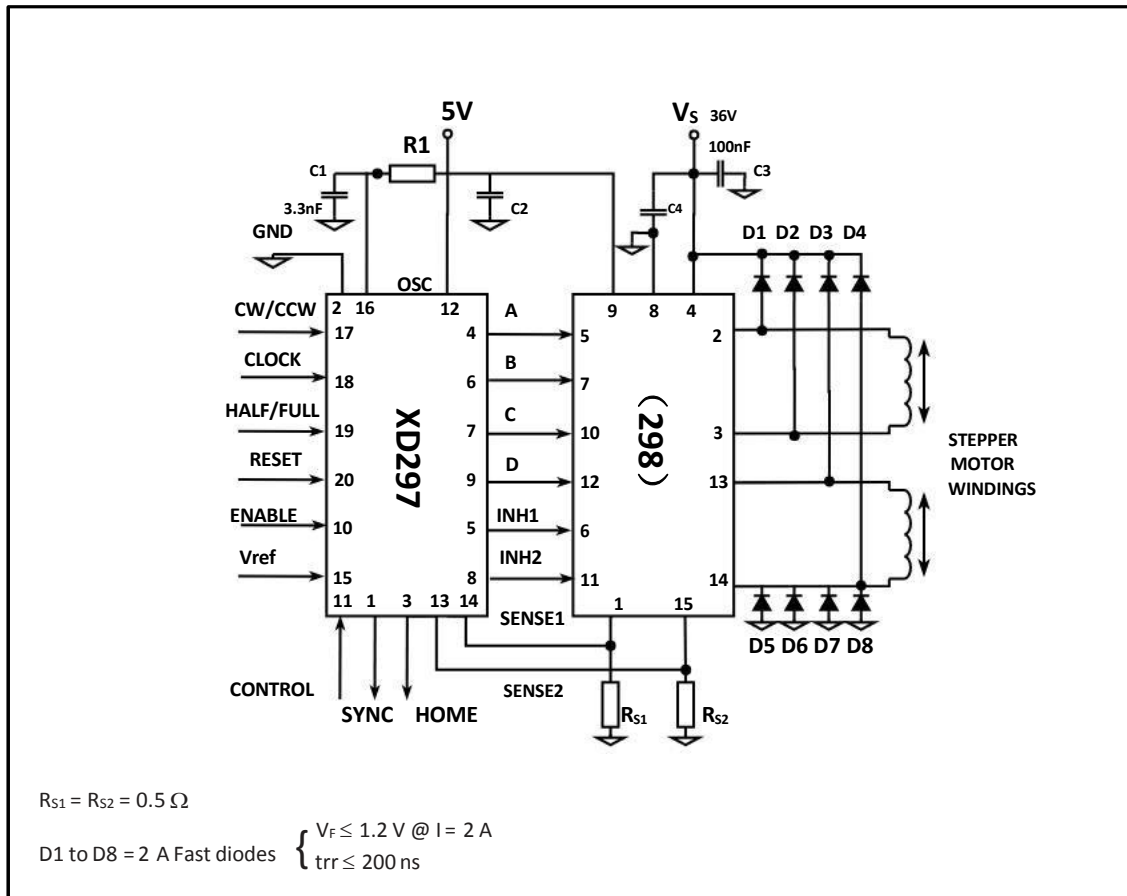

Figure 10 : Two Phase Bipolar Stepper Motor Circuit.

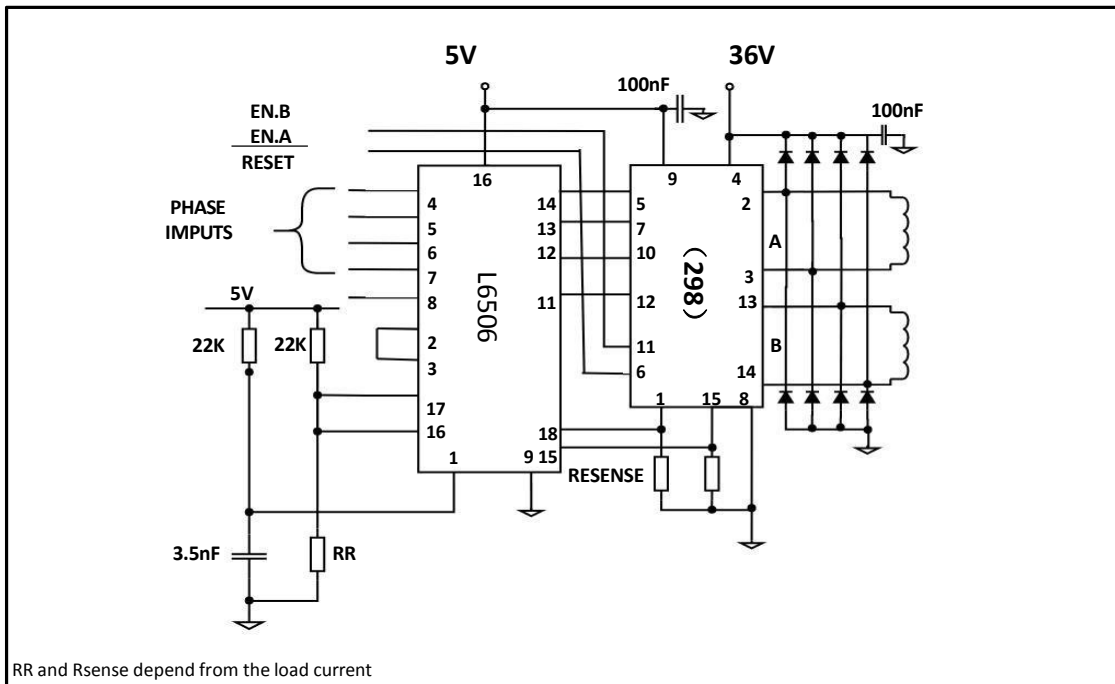

Figure 11 : Two Phase Bipolar Stepper Motor Control Circuit by Using the Current Controller L6506.

7. ORDERING INFORMATION

Ordering Information

Part Number	Device Marking	Package Type	Body size (mm)	Temperature (°C)	MSL	Transport Media	Package Quantity
XZ298N	XZ298N	ZIP15	20.00 * 25.00	-40 to +85	MSL3	Tube 25	500
XL298P	XL298P	HSOP20	15.90 * 11.00	-40 to +85	MSL3	T&R	500

8. DIMENSIONAL DRAWINGS

HSOP20

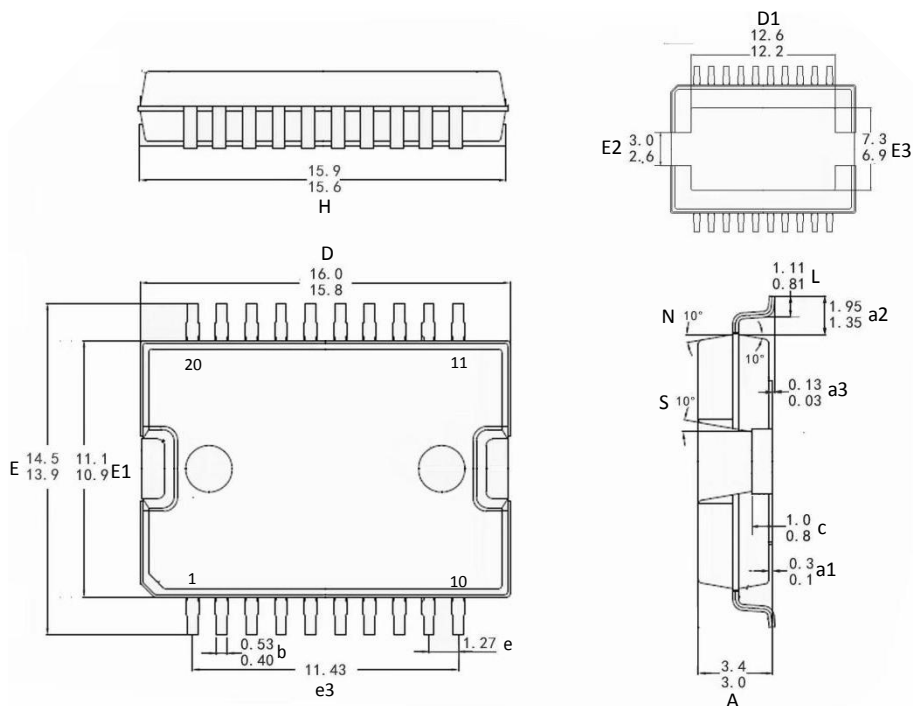

NOTE: Not to scale.

DIM.	mm			inch		
	MIN.	TYP.	MAX.	MIN.	TYP.	MAX.
A	3.0		3.4	0.118		0.134
a1			0.3	0.004		0.012
a2	1.35		1.95	0.053		0.077
a3	0.03		0.13	0.001		0.005
b	0.4		0.53	0.016		0.021
c	0.8		1.1	0.031		0.043
D	15.8		16.0	0.622		0.630
D1	12.2		12.6	0.480		0.496
E	13.9		14.5	0.547		0.570
e		1.27			0.050	
e3		11.43			0.450	
E1	10.9		11.1	0.429		0.437
E2	2.6		3.0	0.102		0.118
E3	6.9		7.3	0.271		0.287
H	15.6		15.9	0.614		0.626
L	0.8		1.1	0.031		0.043
N	10° (max.)					
S	10° (max.)					

ZIP15

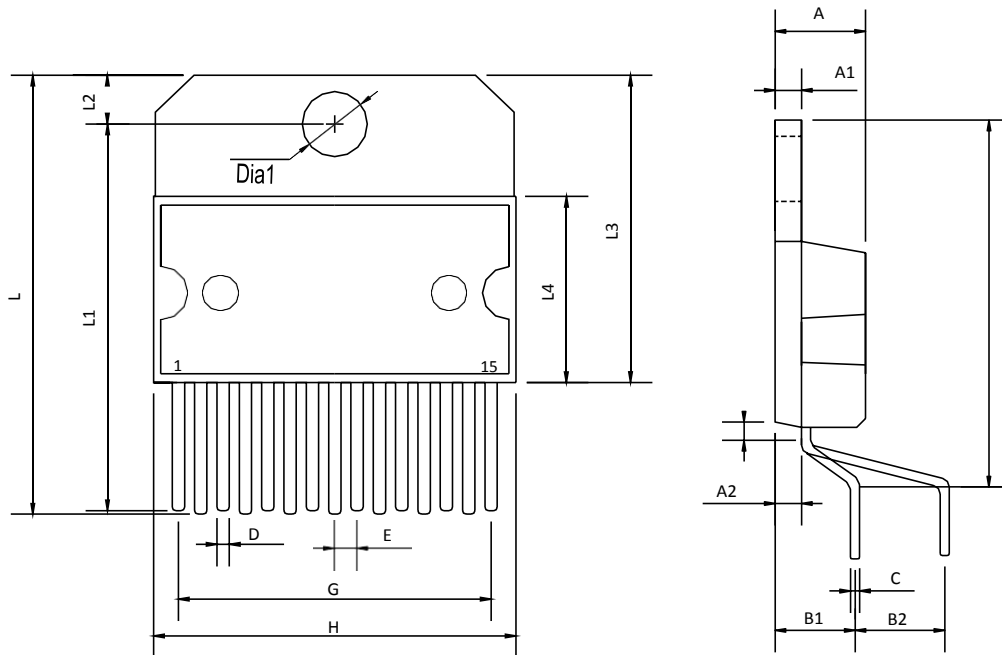

NOTE: Not to scale.

UNIT	A	A1	A2	B1	B2	C	D	E	G	H
mm	5.0	1.6	2.65	4.85	5.43	0.55	0.75	1.52	18.03	21.6
	4.4	1.4	2.45	4.25	4.73	0.49	0.66	1.02	17.53	19.6

UNIT	L	L1	L2	L3	L4	L5	L6	Dia1
mm	25.40	22.50	2.90	17.75	10.9	1.1	21.00	3.85
	24.55	21.69	2.66	17.25	10.3	0.9	20.05	3.65

X-ON Electronics

Largest Supplier of Electrical and Electronic Components

Click to view similar products for [Gate Drivers](#) category:

Click to view products by [XINLUDA](#) manufacturer:

Other Similar products are found below :

[00053P0231](#) [56956](#) [57.404.7355.5](#) [LT4936](#) [57.904.0755.0](#) [5882900001](#) [00600P0005](#) [5951900000](#) [0131700000](#) [00-2240](#) [LTP70N06](#)
[LVP640](#) [5J0-1000LG-SIL](#) [LY2-US-AC240](#) [LY3-UA-DC24](#) [00576P0020](#) [LZNQ2-US-DC12](#) [LZP40N10](#) [0207100000](#) [0207400000](#)
[60100564](#) [60249-1-CUT-TAPE](#) [0134220000](#) [6035](#) [60713816](#) [M15730061](#) [61161-90](#) [61278-0020](#) [6131-204-23149P](#) [6131-205-17149P](#)
[6131-209-15149P](#) [6131-218-17149P](#) [6131-220-21149P](#) [6131-260-2358P](#) [6131-265-11149P](#) [CS1HCPU63](#) [6150300002](#) [6150-5001](#) [CSK-38-](#)
[60006](#) [CSK-38-60008](#) [621A](#) [622-4053LF](#) [6273](#) [M37730026](#) [M40N08MA-H](#) [M55155/29XH06](#) [64-807](#) [65003](#) [65-1930-6](#) [M82310002](#)