

## 1. DESCRIPTION

The 3232 series devices device consists of two line drivers, two line receivers, and a dual charge-pump circuit with 15-kV ESD protection pin to pin (serial-port connection pins, including GND). The device meets the requirements of TIA/EIA-232-F and provides the electrical interface between an asynchronous communication controller and the serial-port connector. The charge pump and four small external capacitors allow operation from a single 3-V to 5.5-V supply. The devices operate at data signaling rates up to 250 kbit/s and a maximum of 30-V/ $\mu\text{s}$  driver output slew rate.

## 2. FEATURES

- RS-232 Bus-Pin ESD Protection
  - $\pm 15$  kV Using Human-Body Model (HBM)
  - $\pm 8\text{kV}$  (IEC6 1000-4-2, Contact Discharge)
  - $\pm 15\text{kV}$  (IEC6 1000-4-2, Air Gap Discharge)
- Meets or Exceeds the Requirements of TIA/EIA-232-F and ITU v.28 Standards
- Operates With 3-V to 5.5-V VCC Supply
- Operates Up To 250 kbit/s
- Two Drivers and Two Receivers
- Low Supply Current: 300  $\mu\text{A}$  (Typical)
- External Capacitors : 4  $\times$  0.1  $\mu\text{F}$
- Accepts 5-V Logic Input With 3.3-V Supply

## 3. Applications

- Industrial PC
- Wired Networks
- Data Centre and Enterprise Networking
- Battery-Powered Systems
- PDAs
- Laptops
- Portable Computers
- Pocket PC
- Handheld Devices

#### 4. PIN CONFIGURATIONS AND FUNCTIONS

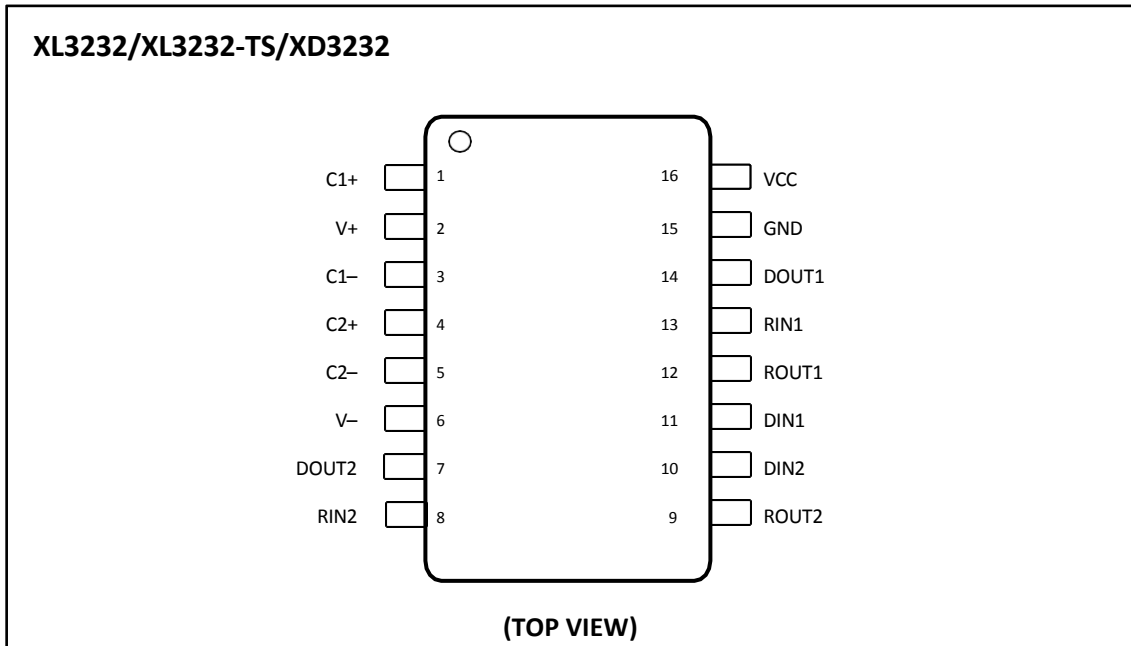

#### Pin Functions

PIN		I/O	DESCRIPTION
NAME	NO.		
C1+	1	—	Positive lead of C1 capacitor
V+	2	O	Positive charge pump output for storage capacitor only
C1 -	3	—	Negative lead of C1 capacitor
C2+	4	—	Positive lead of C2 capacitor
C2 -	5	—	Negative lead of C2 capacitor
V -	6	O	Negative charge pump output for storage capacitor only
DOUT2	7	O	RS232 line data output (to remote RS232 system)
RIN2	8	I	RS232 line data input (from remote RS232 system)
ROUT2	9	O	Logic data output (to UART)
DIN2	10	I	Logic data input (from UART)
DIN1	11	I	Logic data output (from UART)
ROUT1	12	O	Logic data input (to UART)
RIN1	13	I	RS232 line data output (from remote RS232 system)
DOUT1	14	O	RS232 line data input (to remote RS232 system)
GND	15	—	Ground
VCC	16	—	Supply Voltage, Connect to external 3-V to 5.5-V power supply

## 5. FUNCTIONAL BLOCK DIAGRAM

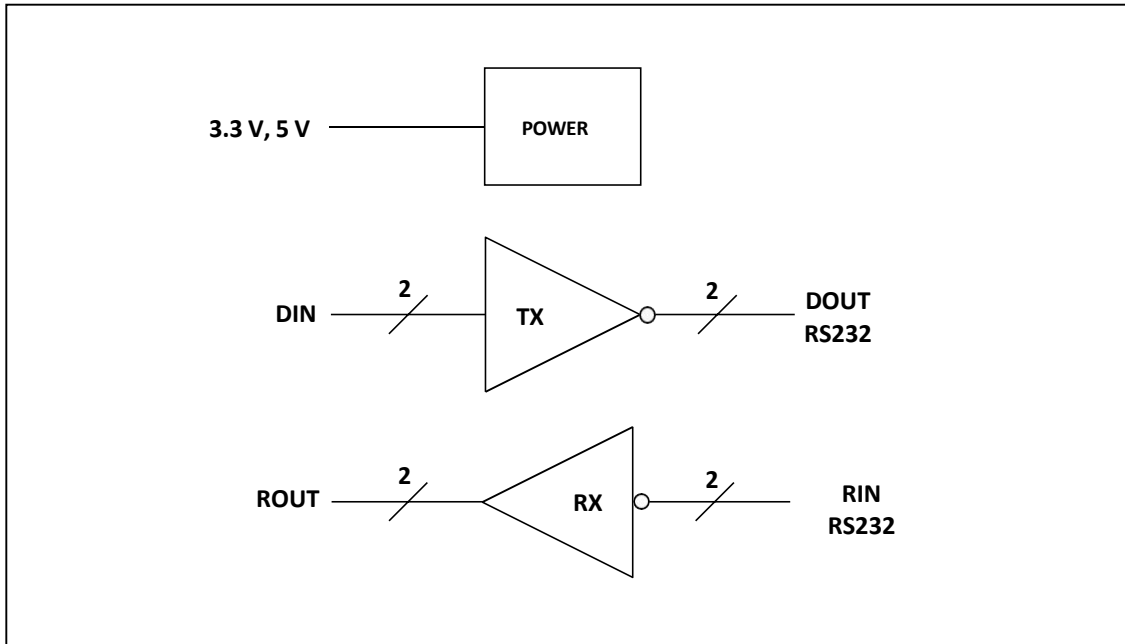

Block Diagram

## 6. SPECIFICATIONS

### 6.1. Absolute Maximum Ratings

over operating free-air temperature range (unless otherwise noted)

		MIN	MAX	UNIT	
V <sub>CC</sub>	Supply voltage <sup>(2)</sup>	- 0.3	6	V	
V <sub>+</sub>	Positive output supply voltage <sup>(2)</sup>	- 0.3	7	V	
V <sub>-</sub>	Negative output supply voltage <sup>(2)</sup>	- 7	0.3	V	
V <sub>+</sub> - V <sub>-</sub>	Supply voltage difference <sup>(2)</sup>		13	V	
V <sub>i</sub>	Input voltage	Drivers	- 0.3	6	V
		Receivers	- 25	25	V
V <sub>o</sub>	Output voltage	Drivers	-13.2	13.2	V
		Receivers	- 0.3	V <sub>CC</sub> + 0.3	V
T <sub>J</sub>	Operating virtual junction temperature		125	°C	
T <sub>stg</sub>	Storage temperature	-45	150	°C	

[1] Operation outside the Absolute Maximum Ratings may cause permanent device damage. Absolute Maximum Ratings do not imply functional operation of the device at these or any other conditions beyond those listed under Recommended Operating Conditions. If used outside the Recommended Operating Conditions but within the Absolute Maximum Ratings, the device may not be fully functional, and this may affect device reliability, functionality, performance, and shorten the device lifetime

[2] All voltages are with respect to network GND.

### 6.2. Thermal Resistance Characteristics

THERMAL METRIC	3232 series			UNIT	
	XL (SOP)	TS (TSSOP)	XD (DIP)		
	16 PINS	16 PINS	16 PINS		
R <sub>θJA</sub>	Junction-to-ambient thermal resistance	85.9	103.1	66.6	°C/W
R <sub>θJCTop</sub>	Junction-to-case (top) thermal resistance	43.1	49.2	32.4	°C/W
R <sub>θJB</sub>	Junction-to-board thermal resistance	44.5	54.8	31.9	°C/W
ψ <sub>JT</sub>	Junction-to-top characterization parameter	10.1	12	8.4	°C/W
ψ <sub>JB</sub>	Junction-to-board characterization parameter	44.1	54.1	31.5	°C/W
R <sub>θJCbott</sub>	Junction-to-case (bottom) thermal resistance	N/A	N/A	N/A	°C/W

### 6.3. ESD Ratings

		VALUE	UNIT
V <sub>(ESD)</sub>	Electrostatic discharge	Human body model (HBM), per ANSI/ ESDA/JEDEC JS-001 RIN, DOUT and DOUT Pins <sup>(1)</sup>	±2000
		Charged-device model (CDM), per JEDEC specification JESD22-C101 All other pins <sup>(2)</sup>	±15,000
		Charging Device Model (CDM), JEDEC Specification JESD22-C101, All Pins <sup>(2)</sup>	±1500

[1] JEDEC document JEP155 states that 500-V HBM allows safe manufacturing with a standard ESD control process.

[2] JEDEC document JEP157 states that 250-V CDM allows safe manufacturing with a standard ESD control process.

## 6.4. Recommended Operating Conditions

See Figure 9-1.

		MIN	NOM	MAX	UNIT	
V <sub>CC</sub>	Supply voltage	V <sub>CC</sub> = 3.3V	3	3.3	3.6	V
		V <sub>CC</sub> = 5V	4.5	5	5.5	
V <sub>IH</sub>	Driver high-level input voltage	DIN	V <sub>CC</sub> = 3.3V	2		V
			V <sub>CC</sub> = 5V	2.4		
V <sub>IL</sub>	Driver low-level input voltage	DIN			0.8	V
V <sub>i</sub>	Driver input voltage	DIN	0		5.5	V
	Receiver input voltage	RIN	-25		25	
T <sub>A</sub>	Operating free-air temperature	XL3232、XL3232-TS XD3232	-40		85	°C

[1] Test conditions are C1–C4 = 0.1 μF (V<sub>CC</sub> = 3.3V ± 0.3V); C1 = 0.047 μF, C2–C4 = 0.33 μF (V<sub>CC</sub> = 5V ± 0.5V)

## 6.5. Electrical Characteristics - DEVICE<sup>(2)</sup>

over recommended ranges of supply voltage and operating free-air temperature (unless otherwise noted) (See Figure 9-1.).

PARAMETER	TEST CONDITIONS	MIN	TYP <sup>(2)</sup>	MAX	UNIT
I <sub>CC</sub> Supply current	No load, V <sub>CC</sub> = 3.3 V or 5 V		0.5	10	mA

[1] All typical values are at V<sub>CC</sub> = 3.3 V or V<sub>CC</sub> = 5 V, and T<sub>A</sub> = 25°C.

[2] Test conditions are C1–C4 = 0.1 μF at V<sub>CC</sub> = 3.3 V ± 0.3 V; C1 = 0.047 μF, C2–C4 = 0.33 μF at V<sub>CC</sub> = 5 V ± 0.5 V.

## 6.6. Electrical Characteristics -DRIVER<sup>(2)</sup>

over recommended ranges of supply voltage and operating free-air temperature (unless otherwise noted) (See Figure 9-1.).

PARAMETER	TEST CONDITIONS	MIN	TYP <sup>(1)</sup>	MAX	UNIT
V <sub>OH</sub> High-level output voltage	DOUT at R <sub>L</sub> = 3 kΩ to GND, DIN = GND	5	5.4		V
V <sub>OL</sub> Low-level output voltage	DOUT at R <sub>L</sub> = 3 kΩ to GND, DIN = V <sub>CC</sub>	-5	-5.4		V
I <sub>IH</sub> High-level input current	V <sub>i</sub> = V <sub>CC</sub>		±0.01	±1	μA
I <sub>IL</sub> Low-level input current	V <sub>i</sub> at GND		±0.01	±1	μA
I <sub>OS</sub> <sup>(2)</sup> Short-circuit output current	V <sub>CC</sub> = 3.6 V, V <sub>O</sub> = 0 V		±35	±60	mA
	V <sub>CC</sub> = 5.5 V, V <sub>O</sub> = 0 V				
r <sub>O</sub> Output resistance	V <sub>CC</sub> , V+, and V- = 0 V, V <sub>O</sub> = ±2 V	300	10M		Ω

[1] All typical values are at V<sub>CC</sub> = 3.3 V or V<sub>CC</sub> = 5 V, and T<sub>A</sub> = 25°C.

[2] Short-circuit durations should be controlled to prevent exceeding the device absolute power dissipation ratings, and not more than one output should be shorted at a time.

[3] Test conditions are C1–C4 = 0.1 μF at V<sub>CC</sub> = 3.3 V ± 0.3 V; C1 = 0.047 μF, C2–C4 = 0.33 μF at V<sub>CC</sub> = 5 V ± 0.5 V.

## 6.7. Electrical Characteristics -RECEIVER

over recommended ranges of supply voltage and operating free-air temperature  
(unless otherwise noted) (See Figure 9-1.).

PARAMETER		TEST CONDITIONS	MIN	TYP <sup>(1)</sup>	MAX	UNIT
V <sub>OH</sub>	High-level output voltage	I <sub>OH</sub> = - 1 mA	V <sub>CC</sub> - 0.6	V <sub>CC</sub> - 0.1		V
V <sub>OL</sub>	Low-level output voltage	I <sub>OL</sub> = 1.6 mA			0.4	V
V <sub>IT+</sub>	Positive-going input threshold voltage	V <sub>CC</sub> = 3.3 V		1.5	2.4	V
		V <sub>CC</sub> = 5 V		1.8	2.4	
V <sub>IT-</sub>	Negative-going input threshold voltage	V <sub>CC</sub> = 3.3 V	0.6	1.2		V
		V <sub>CC</sub> = 5 V	0.8	1.5		
V <sub>hys</sub>	Input hysteresis (V <sub>IT+</sub> - V <sub>IT-</sub> )				0.3	V
r <sub>i</sub>	Input resistance	V <sub>i</sub> = ±3 V to ±25 V	3	5	7	kΩ

[1] All typical values are at V<sub>CC</sub> = 3.3 V or V<sub>CC</sub> = 5 V, and T<sub>A</sub> = 25°C.

[2] Test conditions are C1-C4 = 0.1 μF at V<sub>CC</sub> = 3.3 V ± 0.3 V; C1 = 0.047 μF, C2-C4 = 0.33 μF at V<sub>CC</sub> = 5 V ± 0.5 V.

## 6.8. Switching Characteristics

over recommended ranges of supply voltage and operating free-air temperature  
(unless otherwise noted) (See Figure 9-1.).

PARAMETER		TEST CONDITIONS		MIN	TYP <sup>(2)</sup>	MAX	UNIT
Maximum data rate		RL = 3 kΩ, One DOUT switching,	CL = 1000 pF, see Figure 7-1	150	250		kbit/s
tsk(p)	Driver pulse skew <sup>(3)</sup>	RL = 3 kΩ to 7 kΩ, see Figure 7-2	CL = 150 pF to 2500 pF,		300		ns
SR(tr)	Driver slew rate, transition region (see Figure 7-1)	RL = 3 kΩ to 7 kΩ, V <sub>CC</sub> = 3.3 V	CL = 150 pF to 1000 pF	6		30	V/μs
			CL = 150 pF to 2500 pF	4		30	
t <sub>PLH</sub>	Receiver propagation delay time, low- to high-level output	CL = 150 pF, see Figure 7-3			300		ns
t <sub>PHL</sub>	Receiver propagation delay time, high- to low-level output				300		ns
tsk(p)	Receiver pulse skew <sup>(3)</sup>				300		ns

[1] All typical values are at V<sub>CC</sub> = 3.3 V or V<sub>CC</sub> = 5 V, and T<sub>A</sub> = 25°C.

[2] Pulse skew is defined as |t<sub>PLH</sub> - t<sub>PHL</sub>| of each channel of the same device.

[3] Test conditions are C1-C4 = 0.1 μF at V<sub>CC</sub> = 3.3 V ± 0.3 V; C1 = 0.047 μF, C2-C4 = 0.33 μF at V<sub>CC</sub> = 5 V ± 0.5 V.

### 6.9. Typical Characteristics

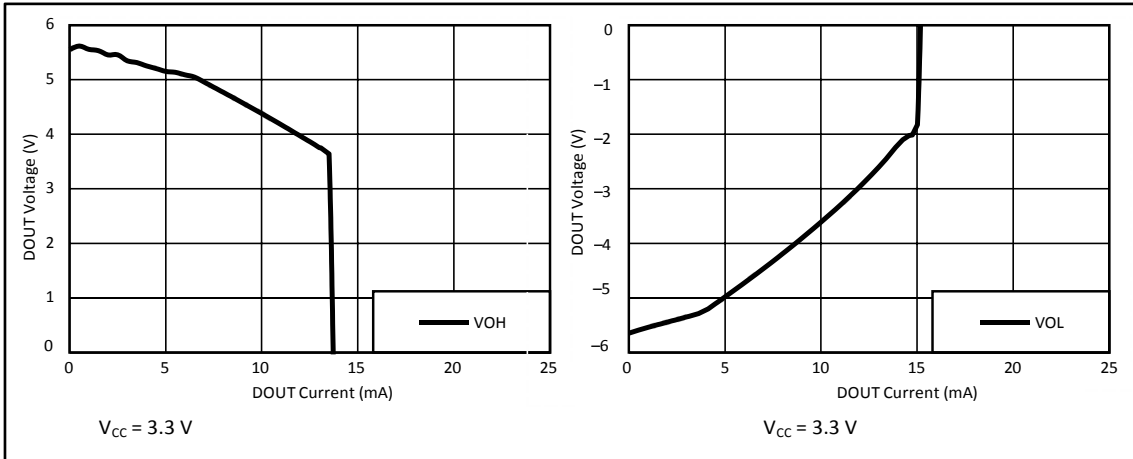

Figure 6-1. DOUT VOH vs Load Current, Both Drivers Loaded

Figure 6-2. DOUT VOL vs Load Current, Both Drivers Loaded

### 7. Parameter Measurement Information

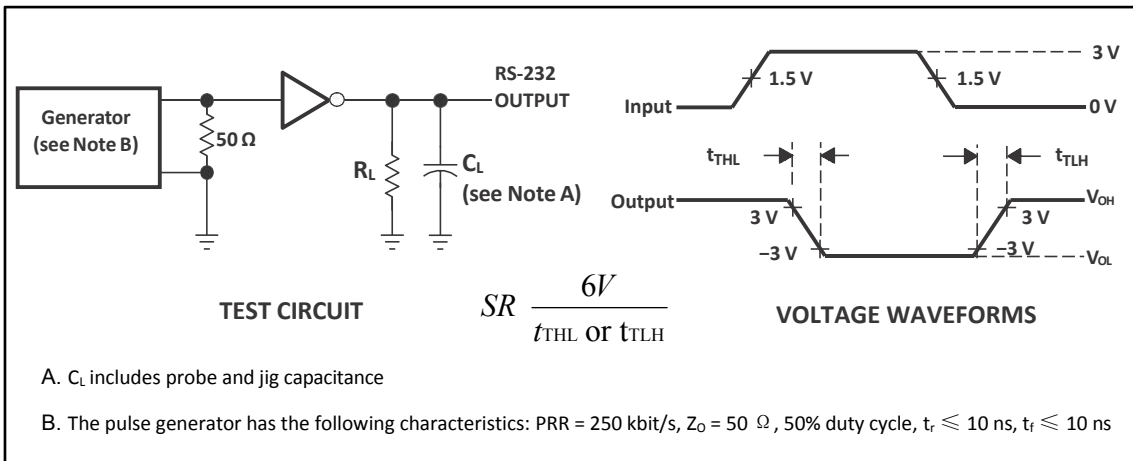

Figure 7-1. Driver Slew Rate

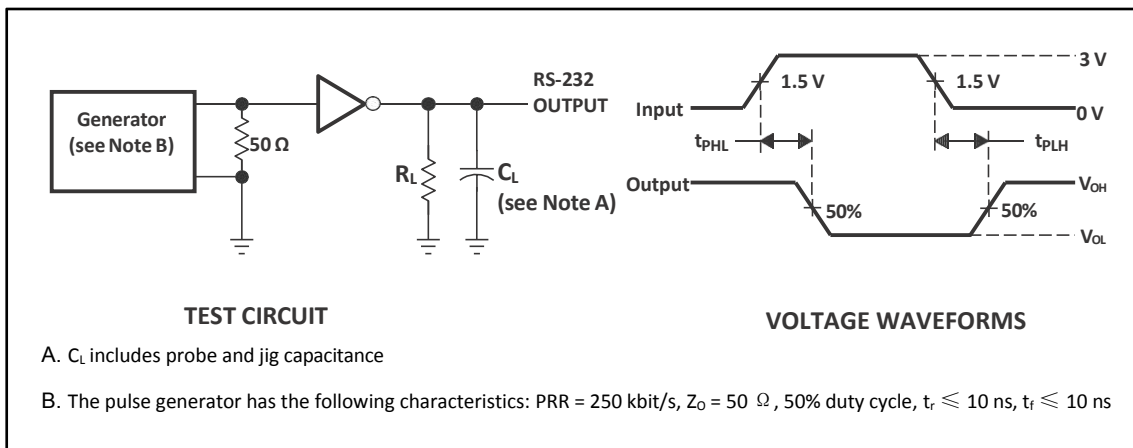
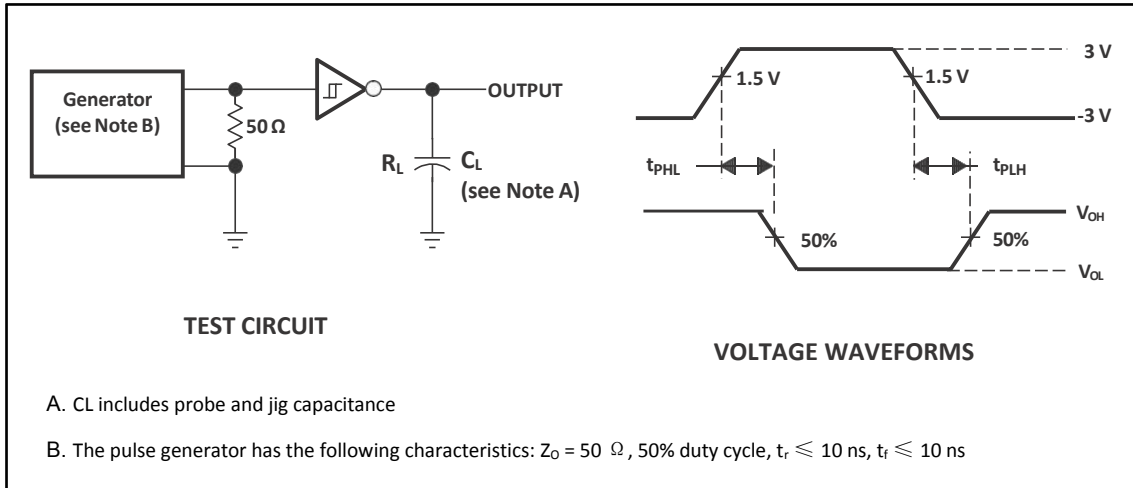

Figure 7-2. Driver Pulse Skew



**Figure 7-3. Receiver Propagation Delay Times**



## 8. Detailed Description

### 8.1. Overview

The 3232 series devices consists of two line drivers, two-line receivers, and a dual charge-pump circuit with IEC61000-4-2 ESD protection terminal to terminal (serial-port connection terminals, including GND). The device meets the requirements of TIA/EIA-232-F and provides the electrical interface between an asynchronous communication controller and the serial-port connector. The charge pump and four small external capacitors allow operation from a single 3-V to 5.5-V supply. The device operates at data signaling rates up to 250 kbit/s and a maximum of 30-V/ $\mu\text{s}$  driver output slew rate. Outputs are protected against shorts to ground.

### 8.2. Feature Description

#### 8.2.1. Power

The power block increases, inverts, and regulates voltage at V+ and V- pins using a charge pump that requires four external capacitors.

#### 8.2.2. RS232 Driver

Two drivers interface standard logic level to RS232 levels. Both DIN inputs must be valid high or low.

#### 8.2.3. RS232 Receiver

Two receivers interface RS232 levels to standard logic levels. An open input will result in a high output on ROUT. Each RIN input includes an internal standard RS232 load.

### 8.3. Device Functional Modes

Table 8-1 and Table 8-2 list the functional modes of the drivers and receivers of 3232.

**Table 8-1. Each Driver<sup>(1)</sup>**

INPUT DIN	OUTPUT DOUT
L	H
H	L

[1] H = high level, L = low level

**Table 8-2. Each Receiver<sup>(1)</sup>**

INPUT RIN	OUTPUT ROUT
L	H
H	L
Open	H

[1] H = high level, L = low level,

Open = input disconnected or connected driver off

#### 8.3.1. VCC Powered by 3 V to 5.5 V

The device is in normal operation.

#### 8.3.2. VCC Unpowered, VCC = 0 V

When 3232 is unpowered, it can be safely connected to an active remote RS232 device.

## 9. Application and Implementation

### 9.1. Application Information

For proper operation, add capacitors as shown in Figure 9-1.

### 9.2. Typical Application

ROUT and DIN connect to UART or general-purpose logic lines. RIN and DOUT lines connect to a RS232 connector or cable.

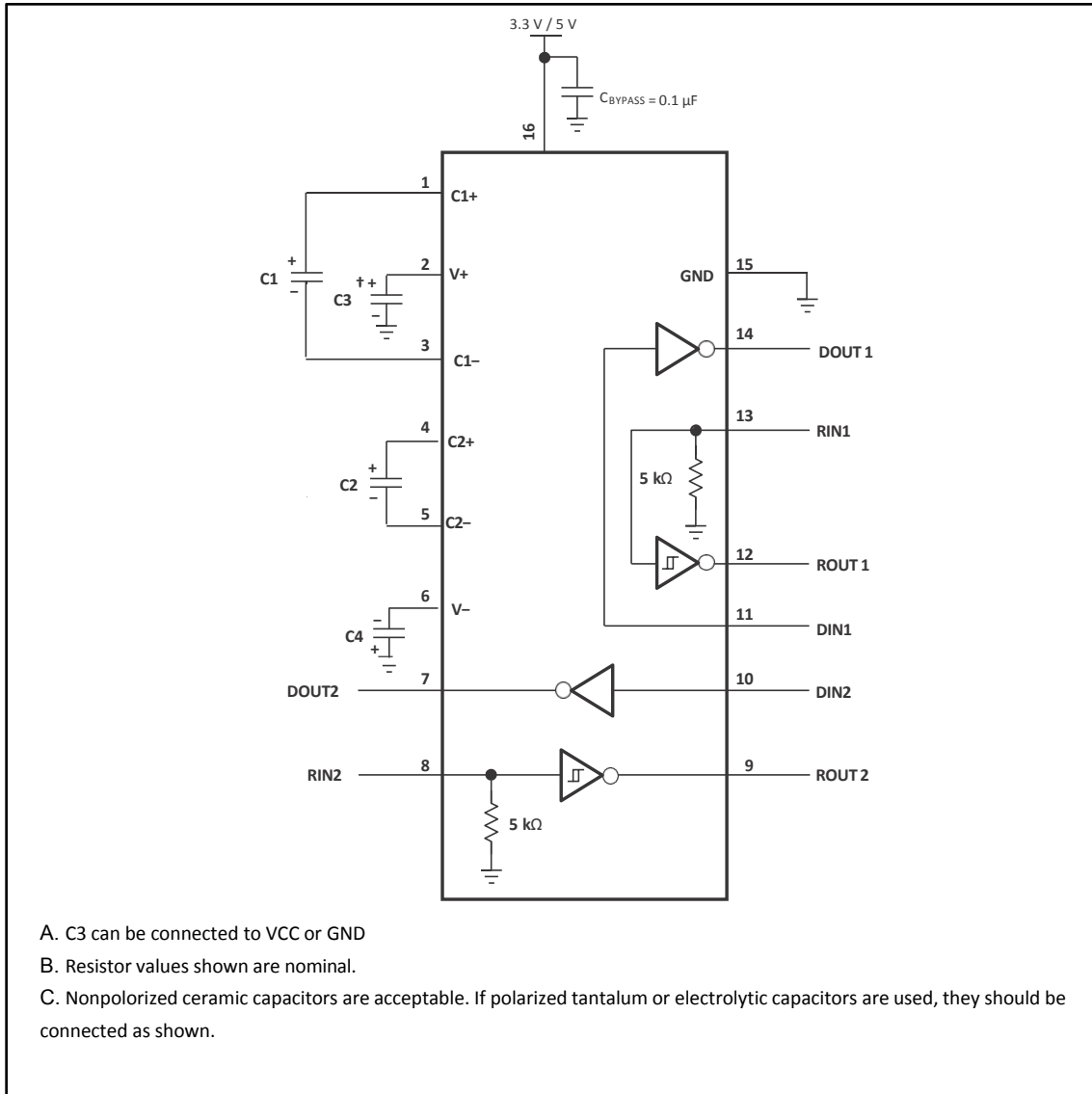

Figure 9-1. Typical Operating Circuit and Capacitor Values

### 9.2.1. Design Requirements

The recommended VCC is 3.3 V or 5 V. 3 V to 5.5 V is also possible The maximum recommended bit rate is 250 kbit/s.

### 9.2.2. Detailed Design Procedure

All DIN inputs must be connected to valid low or high logic levels. Select capacitor values based on VCC level for best performance.

### 9.2.3. Application Curve

Figure 9-2 curves are for 3.3-V VCC and 250-kbit/s alternative bit data stream.

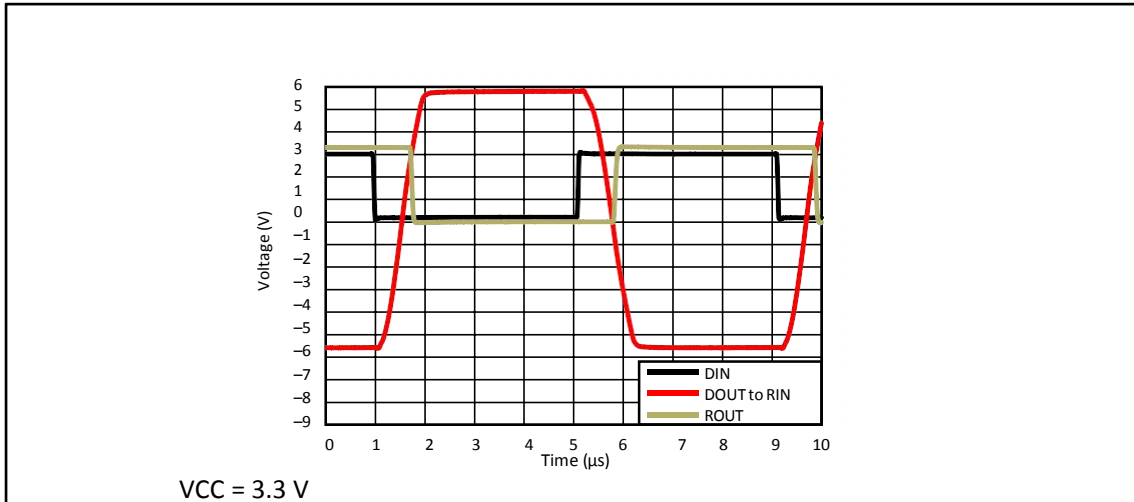

Figure 9-2. 250 kbit/s Driver to Receiver Loopback Timing Waveform

## 10. Power Supply Recommendations

The supply voltage, VCC, should be between 3 V and 5.5 V. Select the values of the charge-pump capacitors using Table 9-1.

## 11. Layout

### 11.1. Layout Guidelines

Keep the external capacitor traces short, specifically on the C1 and C2 nodes that have the fastest rise and fall times.

### 11.2. Layout Example

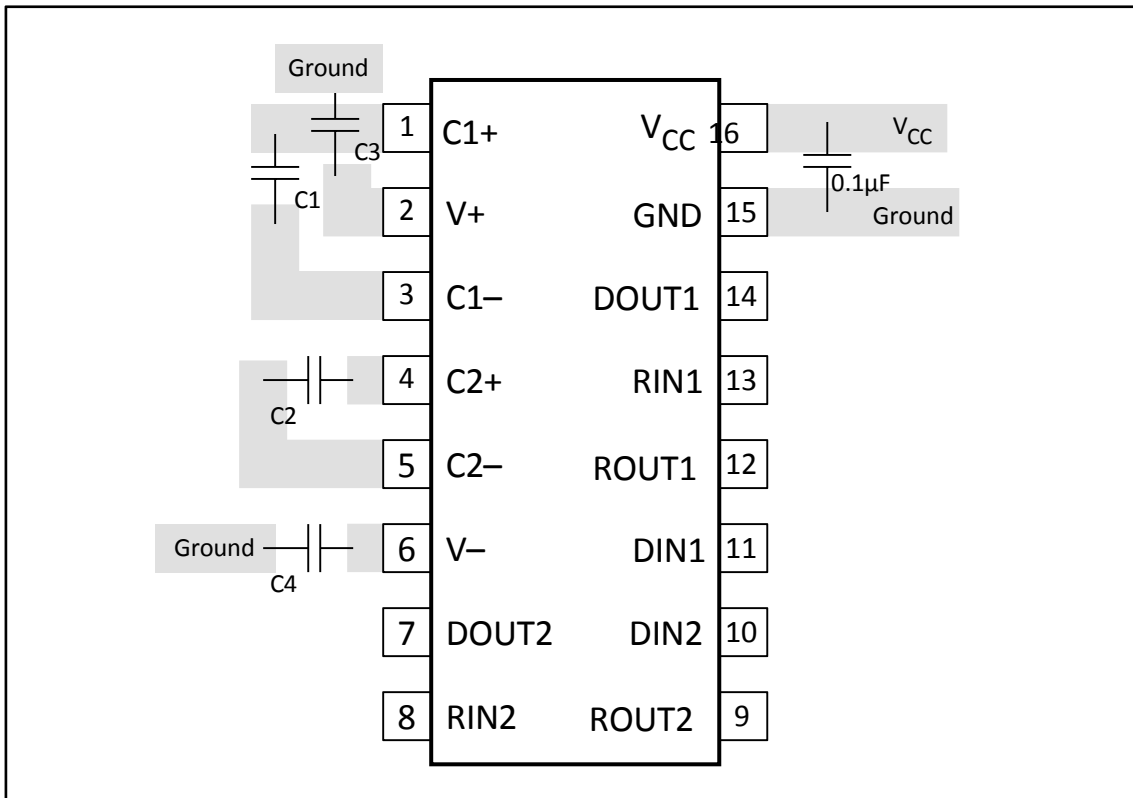

Figure 11-1. Layout Diagram

## 12. ORDERING INFORMATION

### Ordering Information

Part Number	Device Marking	Package Type	Body size (mm)	Temperature (°C)	MSL	Transport Media	Package Quantity
XL3232	XL3232	SOP16	10.00 * 3.95	- 40 to 85	MSL3	T&R	2500
XL3232-TS	XL3232-TS	TSSOP16	5.00 * 3.90	- 40 to 85	MSL3	T&R	2500
XD3232	XD3232	DIP16	19.05 * 6.35	- 40 to 85	MSL3	Tube 25	1000

## 13. DIMENSIONAL DRAWINGS

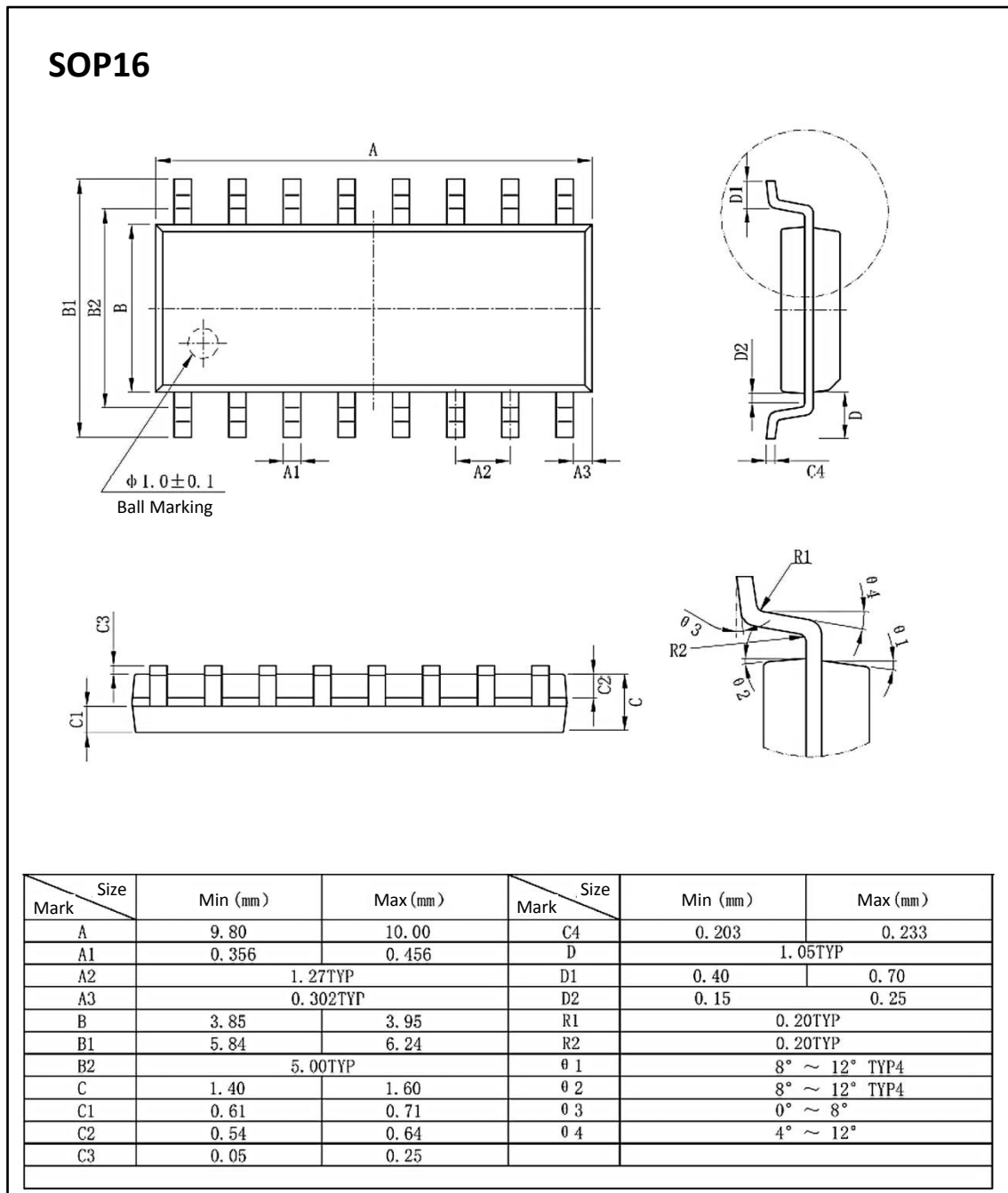

## TSSOP16

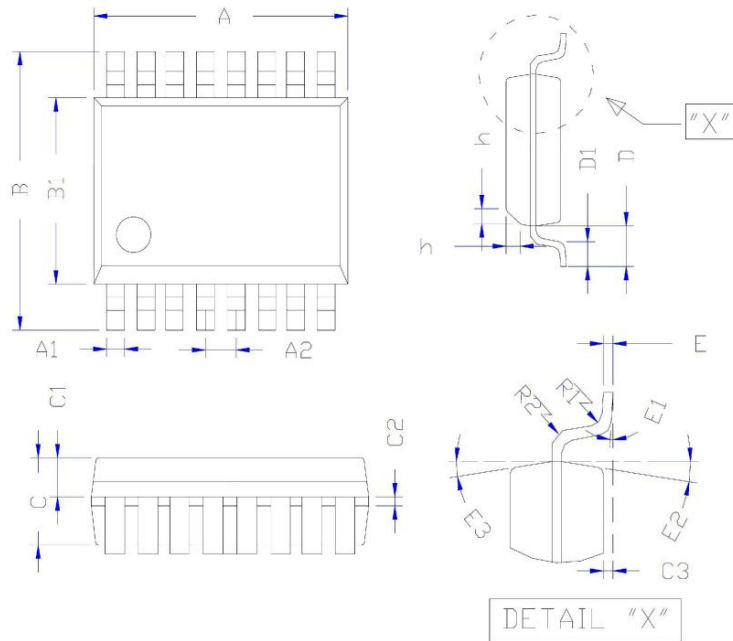

Symbol	Indicate	MIN	NOM	MAX
A	Overall length	4.95	5.00	5.05
A1	Foot width	0.20	0.22	0.24
A2	Foot spacing	0.60	0.65	0.70
B	Span	5.70	6.00	6.30
B1	Colloid width	3.80	3.90	4.00
C	Colloid thickness	0.95	1.00	1.05
C1	Thickness of upper colloid	0.40	0.41	0.42
C2		0.05	0.15	0.25
C3	Stand height	0.02	0.08	0.10
D	Fingle-sided Factory	0.85	1.05	1.25
D1	Foot length	0.40	0.65	0.85
E	Foot Thickness	0.15	0.20	0.25
E2	Foot Angle	0°		8°
h		0.30	0.40	0.50

**DIP16**

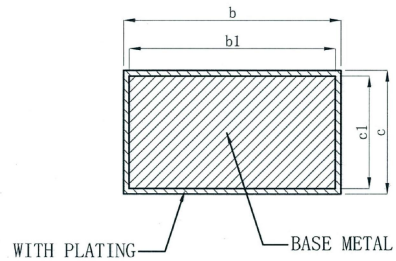
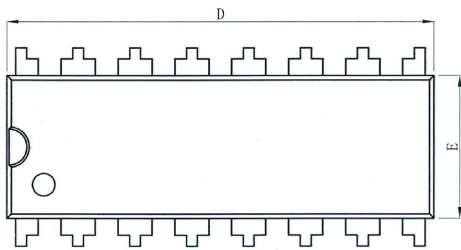
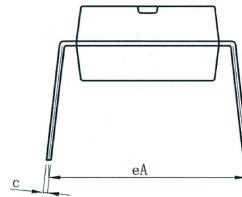
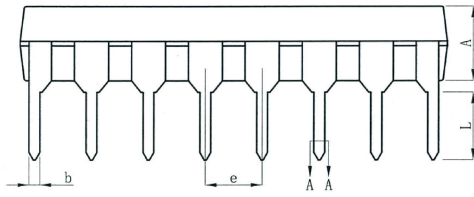

symbol	millimeter		
	Min	Nom	Max
A	3.20	3.30	3.40
b	0.44	---	0.53
b1	0.43	0.46	0.49
c	0.25	---	0.30
c1	0.24	0.25	0.26
D	18.95	19.05	19.15
E	6.25	6.35	6.45
e	2.54BSC		
eA	8.30	8.80	9.30
L	3.00	---	---

## X-ON Electronics

Largest Supplier of Electrical and Electronic Components

*Click to view similar products for [RS-232 Interface IC category](#):*

*Click to view products by [XINLUDA manufacturer](#):*

Other Similar products are found below :

[062191EB](#) [SP508ECF-L](#) [XR32330EBERTR-F](#) [CH438L](#) [HIN202CB](#) [HIN202CBN](#) [HIN202EIB](#) [HIN206CB](#) [HIN206EIA](#) [HIN207EIAZ](#)  
[HIN207EIBZ](#) [HIN208ECB](#) [HIN213EIB](#) [HIN232ACB](#) [HIN232ACBN](#) [HIN232ACP](#) [HIN232CB](#) [HIN232ECP](#) [HIN232IB](#) [HIN232IP](#)  
[HIN238CB](#) [HIN239CB](#) [HIN241CA](#) [ICL232CBE](#) [ICL232IBE](#) [ICL3207ECA](#) [ICL3217ECB](#) [ICL3221CV](#) [ICL3221ECA](#) [ICL3221ECV](#)  
[ICL3221IA](#) [ICL3223CA](#) [ICL3223ECA](#) [ICL3223IA](#) [ICL3225ECA](#) [ICL3232CA](#) [ICL3232CP](#) [ICL3232CV](#) [ICL3232ECB](#) [ICL3232IBN](#)  
[ICL3232IV](#) [ICL3237CA](#) [ICL3237ECA](#) [ICL3238ECA](#) [ICL3241ECA](#) [ICL3243CA](#) [ICL3243CB](#) [ICL3243ECA](#) [ICL3243ECB](#) [ICL3243ECV](#)