

The XD/XL3526 is a high performance pulse width modulator integrated circuit intended for fixed frequency switching regulators and other power control applications.

Functions included in this IC are a temperature compensated voltage reference, sawtooth oscillator, error amplifier, pulse width modulator, pulse metering and steering logic, and two high current totem pole outputs ideally suited for driving the capacitance of power FETs at high speeds.

Additional protective features include soft start and undervoltage lockout, digital current limiting, double pulse inhibit, adjustable dead time and a data latch for single pulse metering. All digital control ports are TTL and B-series CMOS compatible. Active low logic design allows easy wired-OR connections for maximum flexibility. The versatility of this device enables implementation in single-ended or push-pull switching regulators that are transformerless or transformer coupled. The XD/XL3526 is specified over a junction temperature range of 0° to +125°C.

- 8.0 V to 35 V Operation
- 5.0 V $\pm 1\%$ Trimmed Reference
- 1.0 Hz to 400 kHz Oscillator Range
- Dual Source/Sink Current Outputs: ± 100 mA
- Digital Current Limiting
- Programmable Dead Time
- Undervoltage Lockout
- Single Pulse Metering
- Programmable Soft-Start
- Wide Current Limit Common Mode Range
- Guaranteed 6 Unit Synchronization

PIN CONNECTIONS

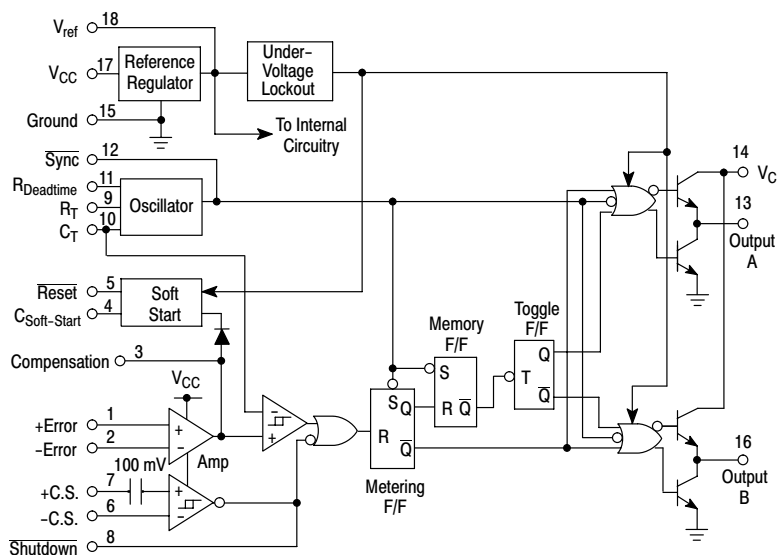
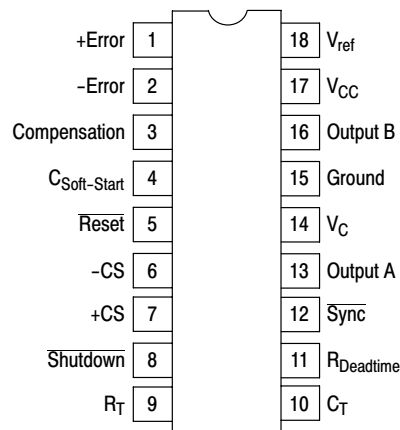

Figure 1. Representative Block Diagram

MAXIMUM RATINGS (Note 1)

Rating	Symbol	Value	Unit
Supply Voltage	V_{CC}	+40	Vdc
Collector Supply Voltage	V_C	+40	Vdc
Logic Inputs		-0.3 to +5.5	V
Analog Inputs		-0.3 to V_{CC}	V
Output Current, Source or Sink	I_O	±200	mA
Reference Load Current ($V_{CC} = 40$ V, Note 2)	I_{ref}	50	mA
Logic Sink Current		15	mA
Power Dissipation $T_A = +25^\circ\text{C}$ (Note 3) $T_C = +25^\circ\text{C}$ (Note 4)	P_D	1000 3000	mW
Thermal Resistance Junction-to-Air	$R_{\theta JA}$	100	$^\circ\text{C}/\text{W}$
Thermal Resistance Junction-to-Case	$R_{\theta JC}$	42	$^\circ\text{C}/\text{W}$
Operating Junction Temperature	T_J	+150	$^\circ\text{C}$
Storage Temperature Range	T_{stg}	-65 to +150	$^\circ\text{C}$
Lead Temperature (Soldering, 10 Seconds)	T_{Solder}	±300	$^\circ\text{C}$

RECOMMENDED OPERATING CONDITIONS

Characteristics	Symbol	Min	Max	Unit
Supply Voltage	V_{CC}	8.0	35	Vdc
Collector Supply Voltage	V_C	4.5	35	Vdc
Output Sink/Source Current (Each Output)	I_O	0	±100	mA
Reference Load Current	I_{ref}	0	20	mA
Oscillator Frequency Range	f_{osc}	0.001	400	kHz
Oscillator Timing Resistor	R_T	2.0	150	k Ω
Oscillator Timing Capacitor	C_T	0.001	20	μF
Available Deadtime Range (40 kHz)	-	3.0	50	%
Operating Junction Temperature Range	T_J	0	+125	$^\circ\text{C}$

1. Values beyond which damage may occur.
2. Maximum junction temperature must be observed.
3. Derate at 10 mW/ $^\circ\text{C}$ for ambient temperatures above +50 $^\circ\text{C}$.
4. Derate at 24 mW/ $^\circ\text{C}$ for case temperatures above +25 $^\circ\text{C}$.

ELECTRICAL CHARACTERISTICS ($V_{CC} = +15\text{ Vdc}$, $T_J = T_{low}$ to T_{high} [Note 6], unless otherwise noted.)

Characteristics	Symbol	Min	Typ	Max	Unit
-----------------	--------	-----	-----	-----	------

REFERENCE SECTION (Note 7)

Reference Output Voltage ($T_J = +25^\circ\text{C}$)	V_{ref}	4.90	5.00	5.10	V
Line Regulation ($+8.0\text{ V} \leq V_{CC} \leq +35\text{ V}$)	Reg_{line}	–	10	30	mV
Load Regulation ($0\text{ mA} \leq I_L \leq 20\text{ mA}$)	Reg_{load}	–	10	50	mV
Temperature Stability	$\Delta V_{ref}/\Delta T$	–	10	–	mV
Total Reference Output Voltage Variation ($+8.0\text{ V} \leq V_{CC} \leq +35\text{ V}$, $0\text{ mA} \leq I_L \leq 20\text{ mA}$)	ΔV_{ref}	4.85	5.00	5.15	V
Short Circuit Current ($V_{ref} = 0\text{ V}$) (Note 5)	I_{SC}	25	80	125	mA

UNDERVOLTAGE LOCKOUT

$\overline{\text{Reset}}$ Output Voltage ($V_{ref} = +3.8\text{ V}$)		–	0.2	0.4	V
$\overline{\text{Reset}}$ Output Voltage ($V_{ref} = +4.8\text{ V}$)		2.4	4.8	–	V

OSCILLATOR SECTION (Note 8)

Initial Accuracy ($T_J = +25^\circ\text{C}$)		–	± 3.0	± 8.0	%
Frequency Stability over Power Supply Range ($+8.0\text{ V} \leq V_{CC} \leq +35\text{ V}$)	$\frac{\Delta f_{osc}}{\Delta V_{CC}}$	–	0.5	1.0	%
Frequency Stability over Temperature ($\Delta T_J = T_{low}$ to T_{high})	$\frac{\Delta f_{osc}}{\Delta T_J}$	–	2.0	–	%
Minimum Frequency ($R_T = 150\text{ k}\Omega$, $C_T = 20\text{ }\mu\text{F}$)	f_{min}	–	0.5	–	Hz
Maximum Frequency ($R_T = 2.0\text{ k}\Omega$, $C_T = 0.001\text{ }\mu\text{F}$)	f_{max}	400	–	–	kHz
Sawtooth Peak Voltage ($V_{CC} = +35\text{ V}$)	$V_{osc(P)}$	–	3.0	3.5	V
Sawtooth Valley Voltage ($V_{CC} = +8.0\text{ V}$)	$V_{osc(V)}$	0.45	0.8	–	V

ERROR AMPLIFIER SECTION (Note 9)

Input Offset Voltage ($R_S \leq 2.0\text{ k}\Omega$)	V_{IO}	–	2.0	10	mV
Input Bias Current	I_{IB}	–	–350	–2000	nA
Input Offset Current	I_{IO}	–	35	200	nA
DC Open Loop Gain ($R_L \geq 10\text{ M}\Omega$)	A_{VOL}	60	72	–	dB
High Output Voltage ($V_{Pin1} - V_{Pin2} \geq +150\text{ mV}$, $I_{source} = 100\text{ }\mu\text{A}$)	V_{OH}	3.6	4.2	–	V
Low Output Voltage ($V_{Pin2} - V_{Pin1} \geq +150\text{ mV}$, $I_{sink} = 100\text{ }\mu\text{A}$)	V_{OL}	–	0.2	0.4	V
Common Mode Rejection Ratio ($R_S \leq 2.0\text{ k}\Omega$)	CMRR	70	94	–	dB
Power Supply Rejection Ratio ($+12\text{ V} \leq V_{CC} \leq +18\text{ V}$)	PSRR	66	80	–	dB

5. Maximum junction temperature must be observed.
6. $T_{low} = 0^\circ\text{C}$ $T_{high} = +125^\circ\text{C}$
7. $I_L = 0\text{ mA}$ unless otherwise noted.
8. $f_{osc} = 40\text{ kHz}$ ($R_T = 4.12\text{ k}\Omega \pm 1\%$, $C_T = 0.01\text{ }\mu\text{F} \pm 1\%$, $R_D = 0\text{ }\Omega$)
9. $0\text{ V} \leq V_{CM} \leq +5.2\text{ V}$.

ELECTRICAL CHARACTERISTICS (continued)

Characteristics	Symbol	Min	Typ	Max	Unit
-----------------	--------	-----	-----	-----	------

PWM COMPARATOR SECTION (Note 10)

Minimum Duty Cycle ($V_{\text{Compensation}} = +0.4 \text{ V}$)	DC_{min}	–	–	0	%
Maximum Duty Cycle ($V_{\text{Compensation}} = +3.6 \text{ V}$)	DC_{max}	45	49	–	%

DIGITAL PORTS (SYNC, SHUTDOWN, RESET)

Output Voltage (High Logic Level) ($I_{\text{source}} = 40 \mu\text{A}$) (Low Logic Level) ($I_{\text{sink}} = 3.6 \text{ mA}$)	V_{OH} V_{OL}	2.4 –	4.0 0.2	– 0.4	V
Input Current — High Logic Level (High Logic Level) ($V_{\text{IH}} = +2.4 \text{ V}$) (Low Logic Level) ($V_{\text{IL}} = +0.4 \text{ V}$)	I_{IH} I_{IL}	– –	–125 –225	–200 –360	μA

CURRENT LIMIT COMPARATOR SECTION (Note 12)

Sense Voltage ($R_{\text{S}} \leq 50 \Omega$)	V_{sense}	80	100	120	mV
Input Bias Current	I_{IB}	–	–3.0	–10	μA

SOFT-START SECTION

Error Clamp Voltage ($\overline{\text{Reset}} = +0.4 \text{ V}$)		–	0.1	0.4	V
$C_{\text{Soft-Start}}$ Charging Current ($\overline{\text{Reset}} = +2.4 \text{ V}$)	I_{CS}	50	100	150	μA

OUTPUT DRIVERS (Each Output, $V_{\text{C}} = +15 \text{ Vdc}$, unless otherwise noted.)

Output High Level $I_{\text{source}} = 20 \text{ mA}$ $I_{\text{source}} = 100 \text{ mA}$	V_{OH}	12.5 12	13.5 13	– –	V
Output Low Level $I_{\text{sink}} = 20 \text{ mA}$ $I_{\text{sink}} = 100 \text{ mA}$	V_{OL}	– –	0.2 1.2	0.3 2.0	V
Collector Leakage, $V_{\text{C}} = +40 \text{ V}$	$I_{\text{C(leak)}}$	–	50	150	μA
Rise Time ($C_{\text{L}} = 1000 \text{ pF}$)	t_{r}	–	0.3	0.6	μs
Fall Time ($C_{\text{L}} = 1000 \text{ pF}$)	t_{f}	–	0.1	0.2	μs
Supply Current ($\overline{\text{Shutdown}} = +0.4 \text{ V}$, $V_{\text{CC}} = +35 \text{ V}$, $R_{\text{T}} = 4.12 \text{ k}\Omega$)	I_{CC}	–	18	30	mA

10. $f_{\text{OSC}} = 40 \text{ kHz}$ ($R_{\text{T}} = 4.12 \text{ k}\Omega \pm 1\%$, $C_{\text{T}} = 0.01 \mu\text{F} \pm 1\%$, $R_{\text{D}} = 0 \Omega$)

11. $0 \text{ V} \leq V_{\text{CM}} \leq +5.2 \text{ V}$

12. $0 \text{ V} \leq V_{\text{CM}} \leq +12 \text{ V}$

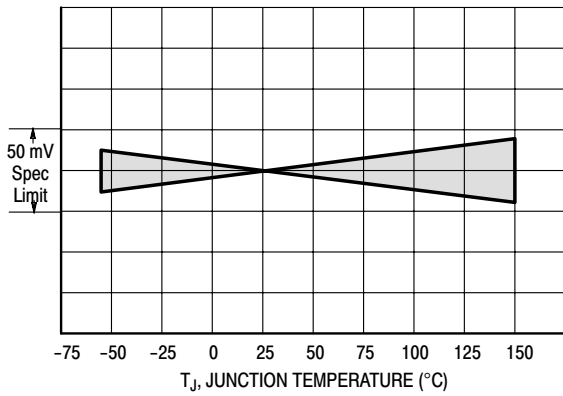

Figure 2. Reference Stability over Temperature

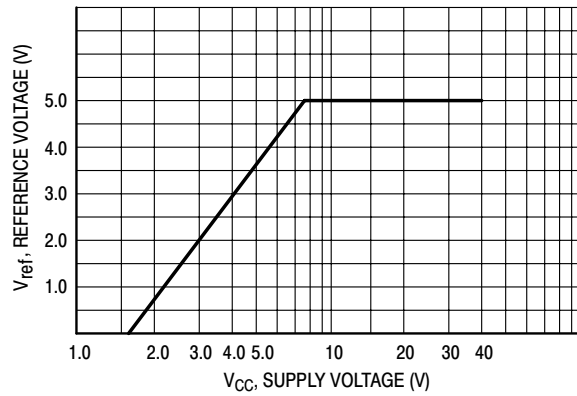

Figure 3. Reference Voltage as a Function of Supply Voltage

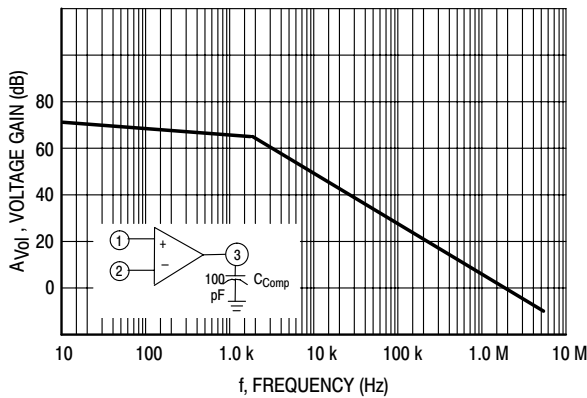

Figure 4. Error Amplifier Open Loop Frequency Response

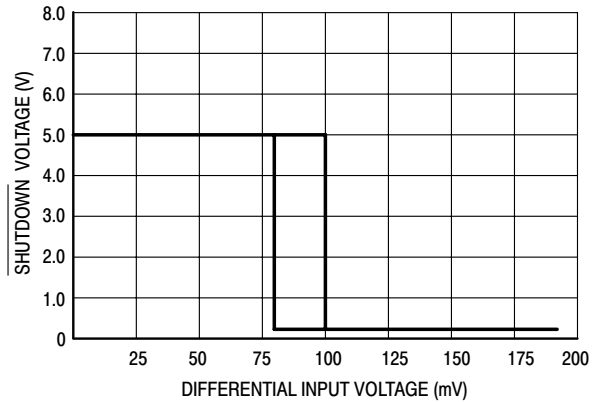

Figure 5. Current Limit Comparator Threshold

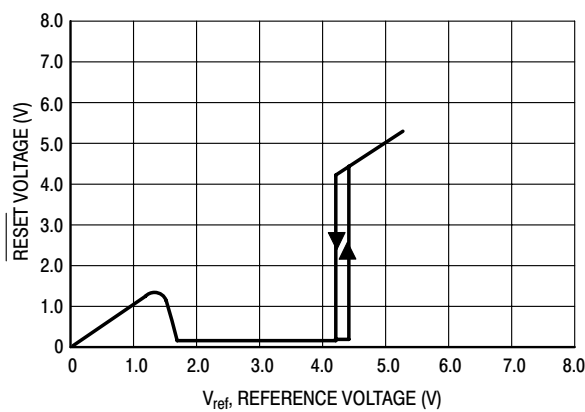

Figure 6. Undervoltage Lockout Characteristic

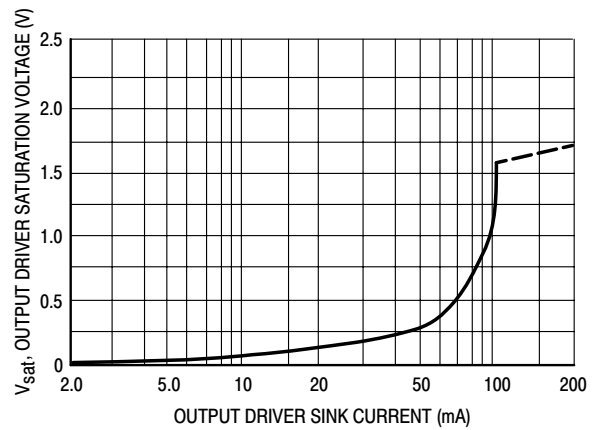

Figure 7. Output Driver Saturation Voltage as a Function of Sink Current

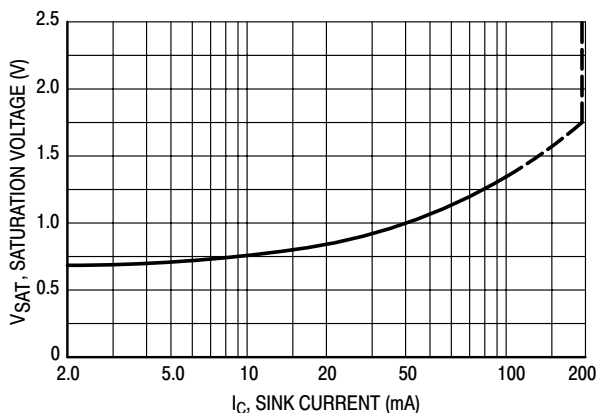

Figure 8. V_C Saturation Voltage as a Function of Sink Current

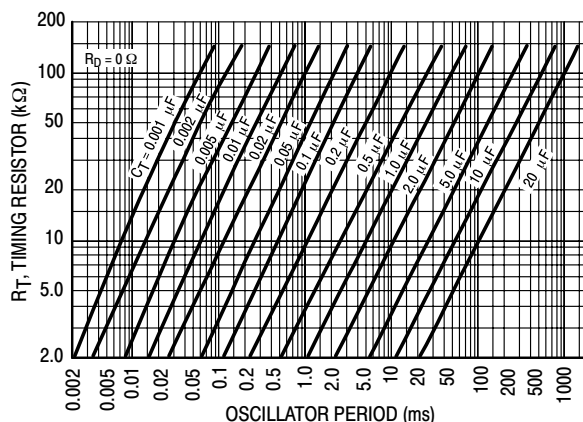

Figure 9. Oscillator Period

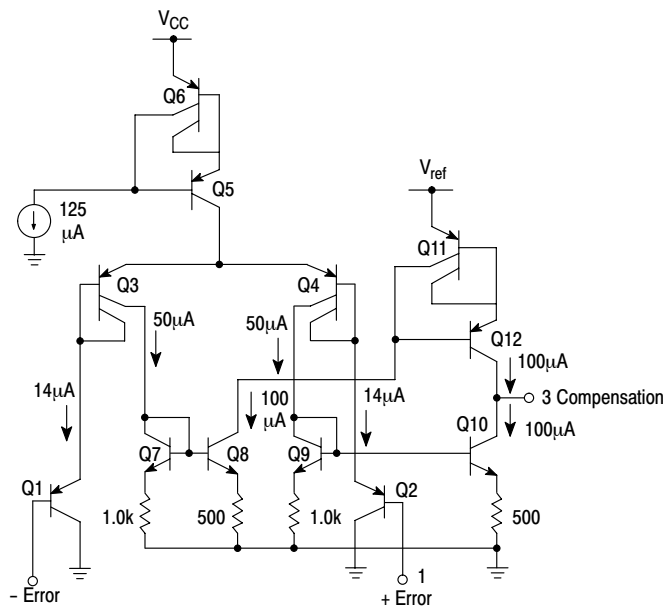

Figure 10. Error Amplifier

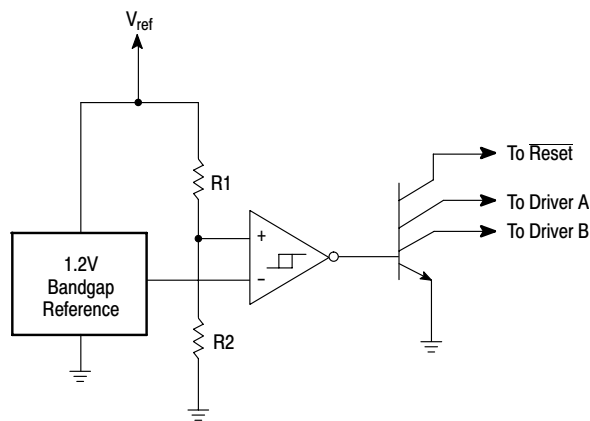
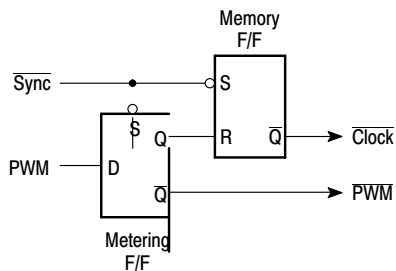

Figure 11. Undervoltage Lockout



The metering Flip-Flop is an asynchronous data latch which suppresses high frequency oscillations by allowing only one PWM pulse per oscillator cycle.

The memory Flip-Flop prevents double pulsing in a push-pull configuration by remembering which output produced the last pulse.

Figure 12. Pulse Processing Logic

APPLICATIONS INFORMATION

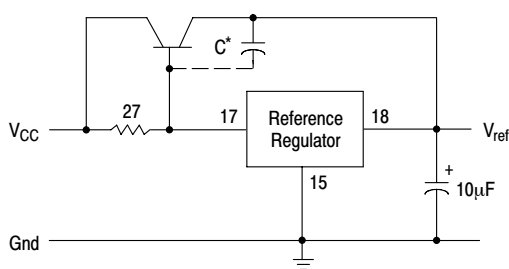

* May be required with some types of transistors

Figure 13. Extending Reference Output Current Capability

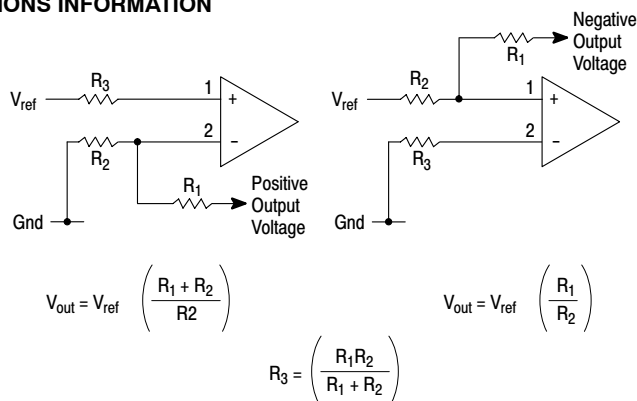

$$V_{out} = V_{ref} \left(\frac{R_1 + R_2}{R_2} \right)$$

$$V_{out} = V_{ref} \left(\frac{R_1}{R_2} \right)$$

$$R_3 = \left(\frac{R_1 R_2}{R_1 + R_2} \right)$$

Figure 14. Error Amplifier Connections

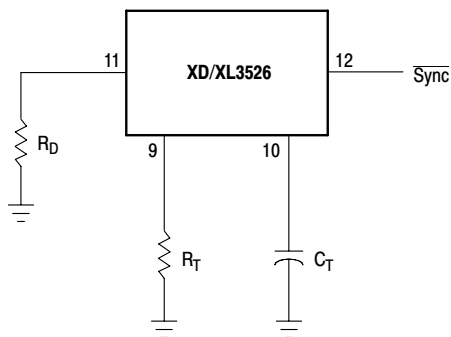
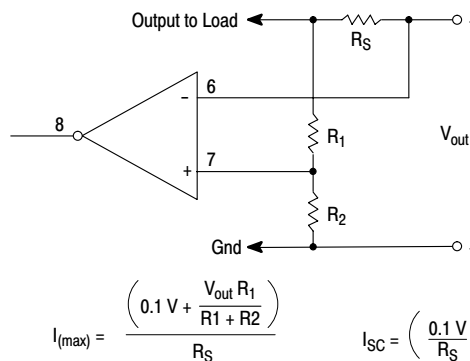

Figure 15. Oscillator Connections



$$I_{(max)} = \frac{0.1V + \frac{V_{out} R_1}{R_1 + R_2}}{R_S}$$

$$I_{SC} = \left(\frac{0.1V}{R_S} \right)$$

Figure 16. Foldback Current Limiting

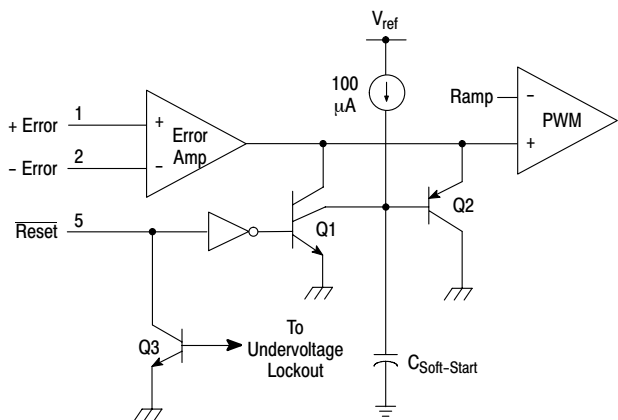
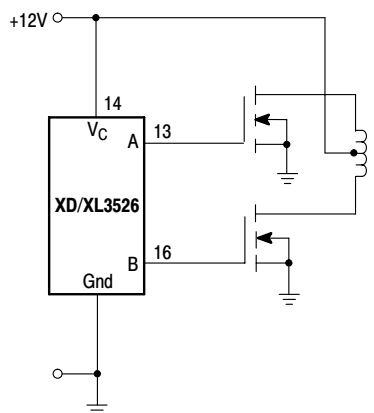

Figure 17. Soft-Start Circuitry



The totem pole output drivers of the XD/XL3526 are ideally suited for driving the input capacitance of power FETs at high speeds.

Figure 18. Driving VMOS Power FETs

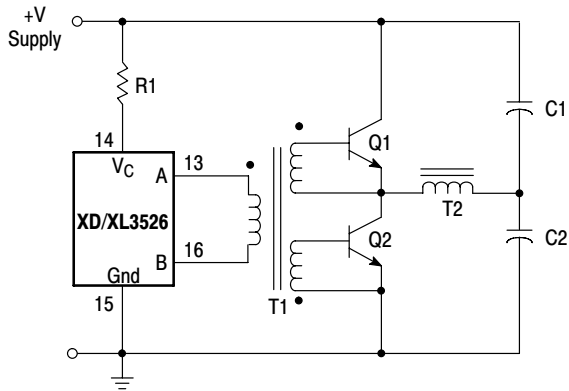
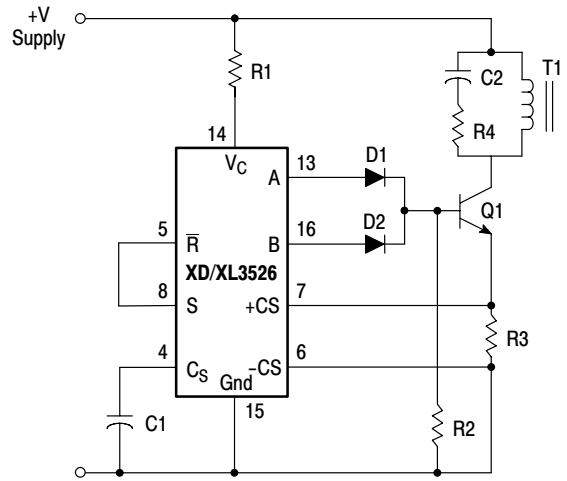

Figure 19. Half-Bridge Configuration



In the above circuit, current limiting is accomplished by using the current limit comparator output to reset the soft-start capacitor.

Figure 20. Flyback Converter with Current Limiting

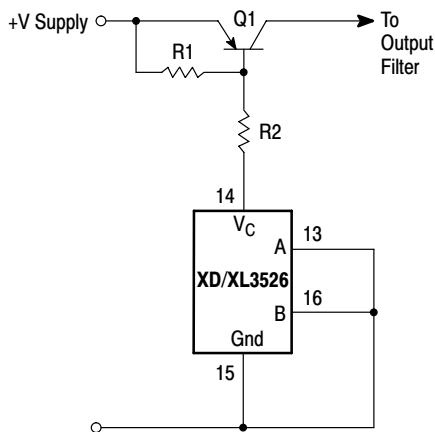

Figure 21. Single-Ended Configuration

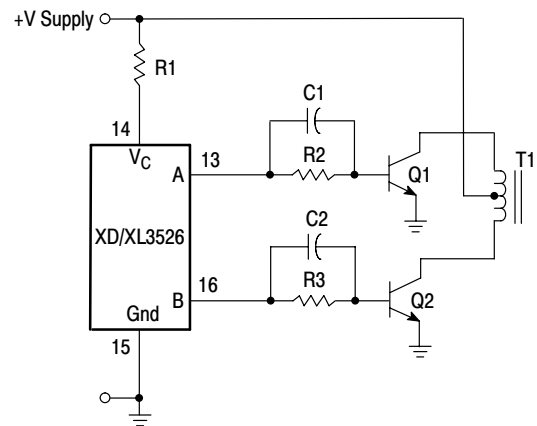
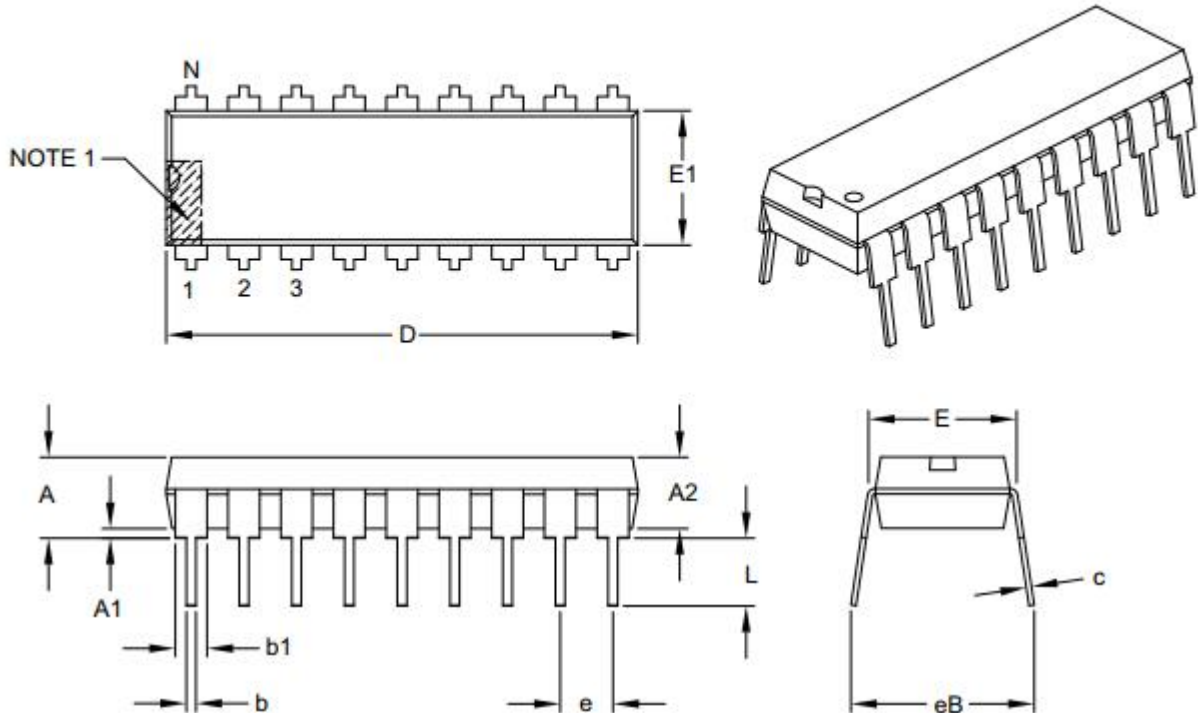

Figure 22. Push-Pull Configuration

DIP



Dimension Limits	Units	INCHES		
		MIN	NOM	MAX
Number of Pins	N	18		
Pitch	e	.100 BSC		
Top to Seating Plane	A	-	-	.210
Molded Package Thickness	A2	.115	.130	.195
Base to Seating Plane	A1	.015	-	-
Shoulder to Shoulder Width	E	.300	.310	.325
Molded Package Width	E1	.240	.250	.280
Overall Length	D	.880	.900	.920
Tip to Seating Plane	L	.115	.130	.150
Lead Thickness	c	.008	.010	.014
Upper Lead Width	b1	.045	.060	.070
Lower Lead Width	b	.014	.018	.022
Overall Row Spacing §	eB	-	-	.430

Notes:

1. Pin 1 visual index feature may vary, but must be located within the hatched area.
2. § Significant Characteristic.
3. Dimensions D and E1 do not include mold flash or protrusions. Mold flash or protrusions shall not exceed .010" per side.
4. Dimensioning and tolerancing per ASME Y14.5M.

SOP

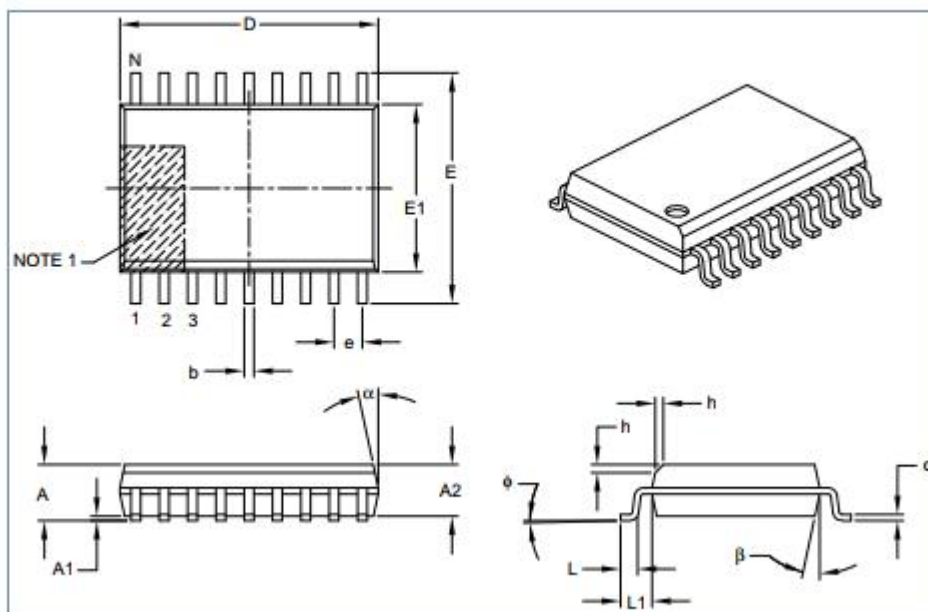

Dimension Limits	Units	MILLIMETERS		
		MIN	NOM	MAX
Number of Pins	N	18		
Pitch	e	1.27 BSC		
Overall Height	A	-	-	2.65
Molded Package Thickness	A2	2.05	-	-
Standoff §	A1	0.10	-	0.30
Overall Width	E	10.30 BSC		
Molded Package Width	E1	7.50 BSC		
Overall Length	D	11.55 BSC		
Chamfer (optional)	h	0.25	-	0.75
Foot Length	L	0.40	-	1.27
Footprint	L1	1.40 REF		
Foot Angle	φ	0°	-	8°
Lead Thickness	c	0.20	-	0.33
Lead Width	b	0.31	-	0.51
Mold Draft Angle Top	α	5°	-	15°
Mold Draft Angle Bottom	β	5°	-	15°

Notes:

1. Pin 1 visual index feature may vary, but must be located within the hatched area.
2. § Significant Characteristic.
3. Dimensions D and E1 do not include mold flash or protrusions. Mold flash or protrusions shall not exceed 0.15 mm per side.
4. Dimensioning and tolerancing per ASME Y14.5M.

X-ON Electronics

Largest Supplier of Electrical and Electronic Components

Click to view similar products for [Switching Voltage Regulators](#) category:

Click to view products by [XINLUDA](#) manufacturer:

Other Similar products are found below :

[FAN53610AUC33X](#) [FAN53611AUC123X](#) [EN6310QA](#) [160215](#) [R3](#) [KE177614](#) [FAN53611AUC12X](#) [MAX809TTR](#) [AST1S31PUR](#)
[NCP81103MNTXG](#) [NCP81203PMNTXG](#) [NCP81208MNTXG](#) [PCA9412AUKZ](#) [NCP81109GMNTXG](#) [NCP81109JMNTXG](#) [MP2161AGJ-Z](#)
[NCP81241MNTXG](#) [MPQ4481GU-AEC1-P](#) [MP8756GD-P](#) [MPQ2171GJ-P](#) [MPQ2171GJ-AEC1-P](#) [MP2171GJ-P](#) [NCV1077CSTBT3G](#)
[MP28160GC-Z](#) [MPM3509GQVE-AEC1-P](#) [XDPE132G5CG000XUMA1](#) [MP5461GC-P](#) [IR3888AMTRPBFAUMA1](#) [MPQ4409GQBE-AEC1-](#)
[P](#) [S-19903DA-A8T1U7](#) [S-19903CA-A6T8U7](#) [S-19903CA-S8T1U7](#) [S-19902BA-A6T8U7](#) [S-19902CA-A6T8U7](#) [AP7361EA-SPR-13](#)
[AP7361EA-33DR-13](#) [S-19902AA-A6T8U7](#) [S-19903AA-A6T8U7](#) [S-19902AA-S8T1U7](#) [S-19902BA-A8T1U7](#) [AU8310](#) [LMR36503R5RPER](#)
[LMR36503RFRPER](#) [LMR54406DBVR](#) [XC9110C301MR-G](#) [XC9141A50CMR-G](#) [XCL206F083CR-G](#) [XCL210A111GR-G](#)
[LTM4663EV#PBF](#) [LD5537B1GL](#)