

XD567 DIP8 / XL567 SOP8

1 Features

- 20 to 1 Frequency Range With an External Resistor
- Logic Compatible Output With 100-mA Current Sinking Capability
- Bandwidth Adjustable From 0 to 14%
- High Rejection of Out of Band Signals and Noise
- Immunity to False Signals
- Highly Stable Center Frequency
- Center Frequency Adjustable from 0.01 Hz to 500 kHz

2 Applications

- Touch Tone Decoding
- Precision Oscillator
- Frequency Monitoring and Control
- Wide Band FSK Demodulation
- Ultrasonic Controls
- Carrier Current Remote Controls
- Communications Paging Decoders

3 Description

The XDXL/567 are general purpose tone decoders designed to provide a saturated transistor switch to ground when an input signal is present within the passband. The circuit consists of an I and Q detector driven by a voltage controlled oscillator which determines the center frequency of the decoder. External components are used to independently set center frequency, bandwidth and output delay.

4 Simplified Diagram

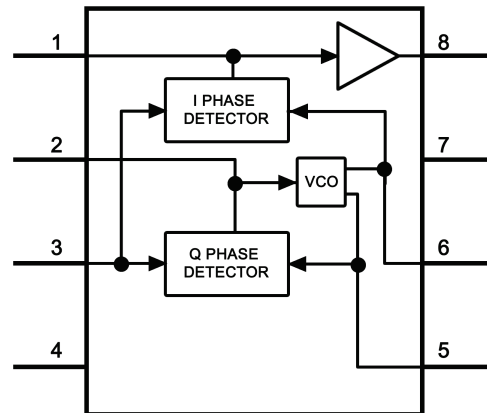

XD567 DIP8 / XL567 SOP8

5 Device Comparison Table

DEVICE NAME	DESCRIPTION
XDXL/567	General Purpose Tone Decoder

6 Pin Configuration and Functions

8-Pin
PDIP (P) and SOIC (D) Package
Top View

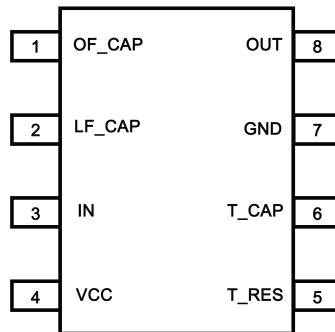

Pin Functions

PIN		TYPE	DESCRIPTION
NAME	NO.		
GND	7	P	Circuit ground.
IN	3	I	Device input.
LF_CAP	2	I	Loop filter capacitor pin (LPF of the PLL).
OUT	8	O	Device output.
OF_CAP	1	I	Output filter capacitor pin.
T_CAP	5	I	Timing capacitor connection pin.
T_RES	6	I	Timing resistor connection pin.
VCC	4	P	Voltage supply pin.

7 Specifications

7.1 Absolute Maximum Ratings⁽¹⁾⁽²⁾⁽³⁾

		MIN	MAX	UNIT
Supply Voltage Pin			9	V
Power Dissipation ⁽⁴⁾			1100	mW
V ₈			15	V
V ₃			-10	V
V ₃			V ₄ + 0.5	V
Operating Temperature Range	XDXL/567	0	70	°C
	PDIP Package	Soldering (10 s)	260	°C
		Vapor Phase (60 s)	215	°C
	SOIC Package	Infrared (15 s)	220	°C
Storage temperature range, T _{stg}		-65	150	°C

- (1) Absolute Maximum Ratings indicate limits beyond which damage to the device may occur. *Recommended Operating Conditions* indicate conditions for which the device is functional, but do not ensure specific performance limits. *Electrical Characteristics* state DC and AC electrical specifications under particular test conditions which ensure specific performance limits. This assumes that the device is within the Recommended Operating Conditions. Specifications are not ensured for parameters where no limit is given, however, the typical value is a good indication of device performance.

7.2 Recommended Operating Conditions

over operating free-air temperature range (unless otherwise noted)

		MIN	MAX	UNIT
V _{CC}	Supply Voltage	3.5	8.5	V
V _{IN}	Input Voltage Level	-8.5	8.5	V
T _A	Operating Temperature Range	-20	120	°C

7.3 Thermal Information

THERMAL METRIC ⁽¹⁾		XDXL/567		UNIT
		D	P	
		8 PINS		
R _{θJA}	Junction-to-ambient thermal resistance	107.5	53.0	°C/W
R _{θJC(top)}	Junction-to-case (top) thermal resistance	54.6	42.3	
R _{θJB}	Junction-to-board thermal resistance	47.5	30.2	
ψ _{JT}	Junction-to-top characterization parameter	10.0	19.6	
ψ _{JB}	Junction-to-board characterization parameter	47.0	30.1	

- (1) For more information about traditional and new thermal metrics, see the *IC Package Thermal Metrics* application report, SPRA953.

XD567 DIP8 / XL567 SOP8

7.4 Electrical Characteristics

AC Test Circuit, $T_A = 25^\circ\text{C}$, $V^+ = 5\text{ V}$

PARAMETER	TEST CONDITIONS	XDXL/567			XDXL/567			UNIT
		MIN	TYP	MAX	MIN	TYP	MAX	
Power Supply Voltage Range		4.75	5.0	9.0	4.75	5.0	9.0	V
Power Supply Current Quiescent	$R_L = 20\text{k}$		6	8		7	10	mA
Power Supply Current Activated	$R_L = 20\text{k}$		11	13		12	15	mA
Input Resistance		18	20		15	20		k Ω
Smallest Detectable Input Voltage	$I_L = 100\text{ mA}$, $f_i = f_o$		20	25		20	25	mVrms
Largest No Output Input Voltage	$I_C = 100\text{ mA}$, $f_i = f_o$	10	15		10	15		mVrms
Largest Simultaneous Outband Signal to Inband Signal Ratio			6			6		dB
Minimum Input Signal to Wideband Noise Ratio	$B_n = 140\text{ kHz}$		-6			-6		dB
Largest Detection Bandwidth		12	14	16	10	14	18	% of f_o
Largest Detection Bandwidth Skew			1	2		2	3	% of f_o
Largest Detection Bandwidth Variation with Temperature			± 0.1			± 0.1		%/ $^\circ\text{C}$
Largest Detection Bandwidth Variation with Supply Voltage	4.75 – 6.75 V		± 1	± 2		± 1	± 5	%V
Highest Center Frequency		100	500		100	500		kHz
Center Frequency Stability (4.75 – 5.75 V)	$0 < T_A < 70$ $-55 < T_A < +125$		35 ± 60 35 ± 140			35 ± 60 35 ± 140		ppm/ $^\circ\text{C}$ ppm/ $^\circ\text{C}$
Center Frequency Shift with Supply Voltage	4.75 V – 6.75 V 4.75 V – 9 V		0.5	1.0 2.0		0.4	2.0 2.0	%/V %/V
Fastest ON-OFF Cycling Rate			$f_o/20$			$f_o/20$		
Output Leakage Current	$V_g = 15\text{ V}$		0.01	25		0.01	25	μA
Output Saturation Voltage	$e_i = 25\text{ mV}$, $I_g = 30\text{ mA}$ $e_i = 25\text{ mV}$, $I_g = 100\text{ mA}$		0.2 0.6	0.4 1.0		0.2 0.6	0.4 1.0	V
Output Fall Time			30			30		ns
Output Rise Time			150			150		ns

7.5 Typical Characteristics

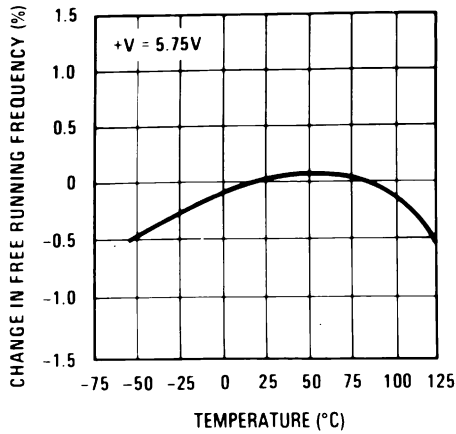

Figure 1. Typical Frequency Drift

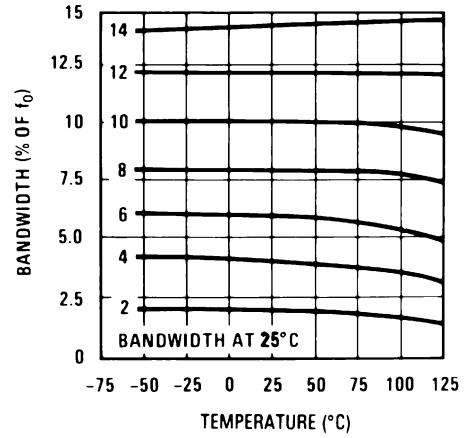

Figure 2. Typical Bandwidth Variation

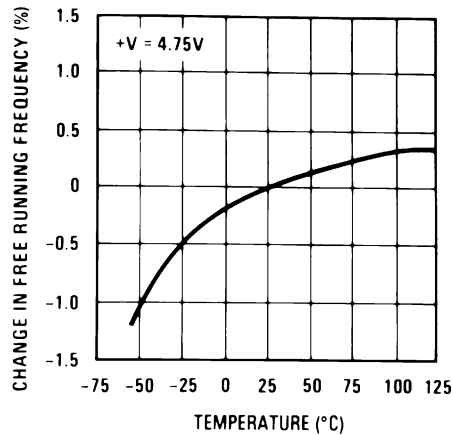

Figure 3. Typical Frequency Drift

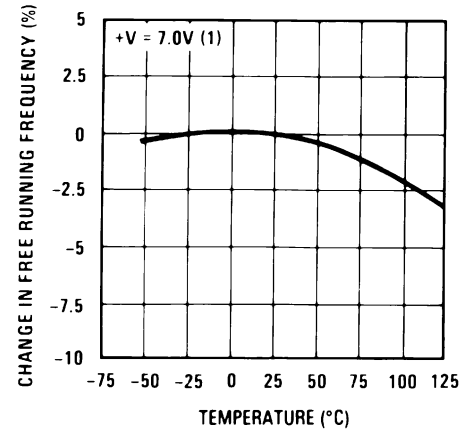

Figure 4. Typical Frequency Drift

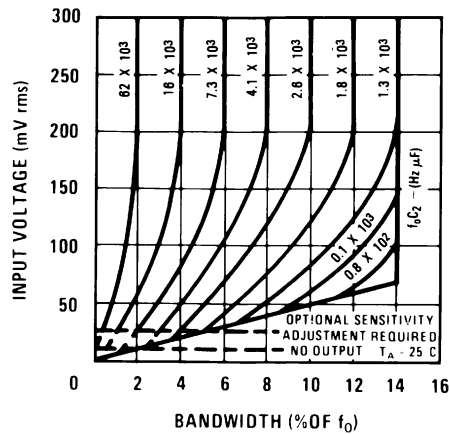

Figure 5. Bandwidth vs Input Signal Amplitude

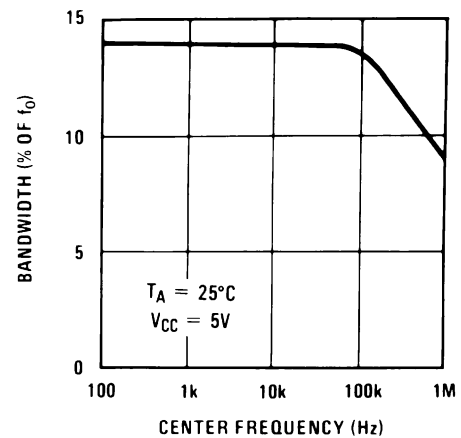

Figure 6. Largest Detection Bandwidth

Typical Characteristics (continued)

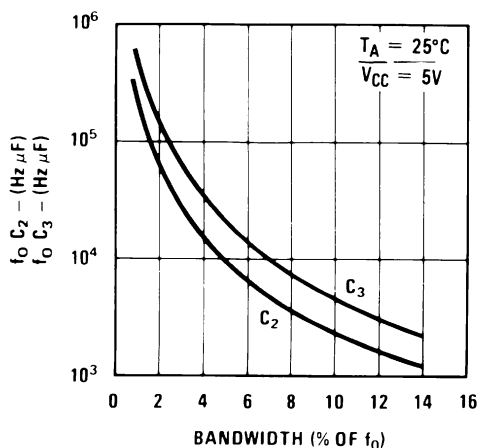

Figure 7. Detection Bandwidth as a Function of C_2 and C_3

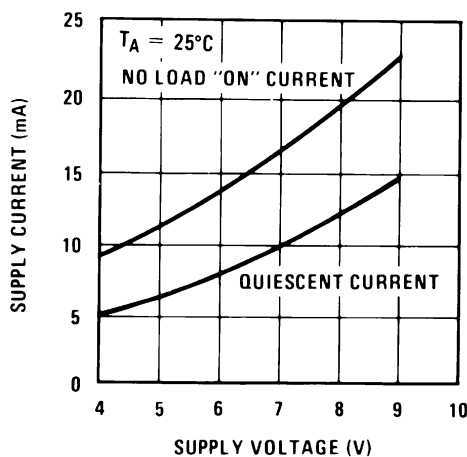

Figure 8. Typical Supply Current vs Supply Voltage

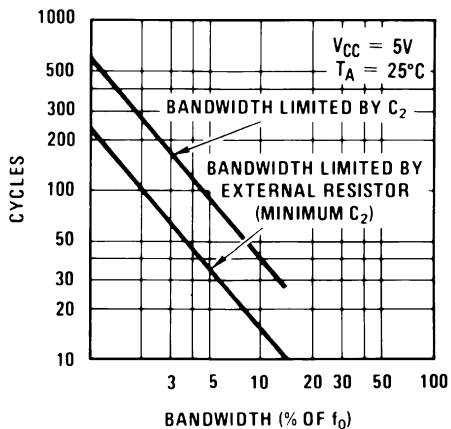

Figure 9. Greatest Number of Cycles Before Output

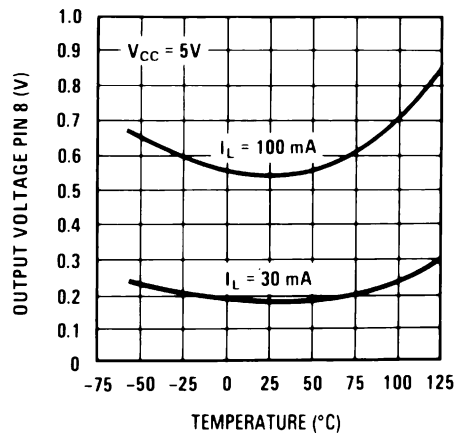

Figure 10. Typical Output Voltage vs Temperature

8 Detailed Description

8.1 Overview

The XD567 is a general purpose tone decoder. The circuit consists of I and Q detectors driven by a voltage controlled oscillator which determines the center frequency of the decoder. This device is designed to provide a transistor switch to ground output when the input signal frequency matches the center frequency pass band. Center frequency is set by an external timing circuit composed by a capacitor and a resistor. Bandwidth and output delay are set by external capacitors.

8.2 Functional Block Diagram

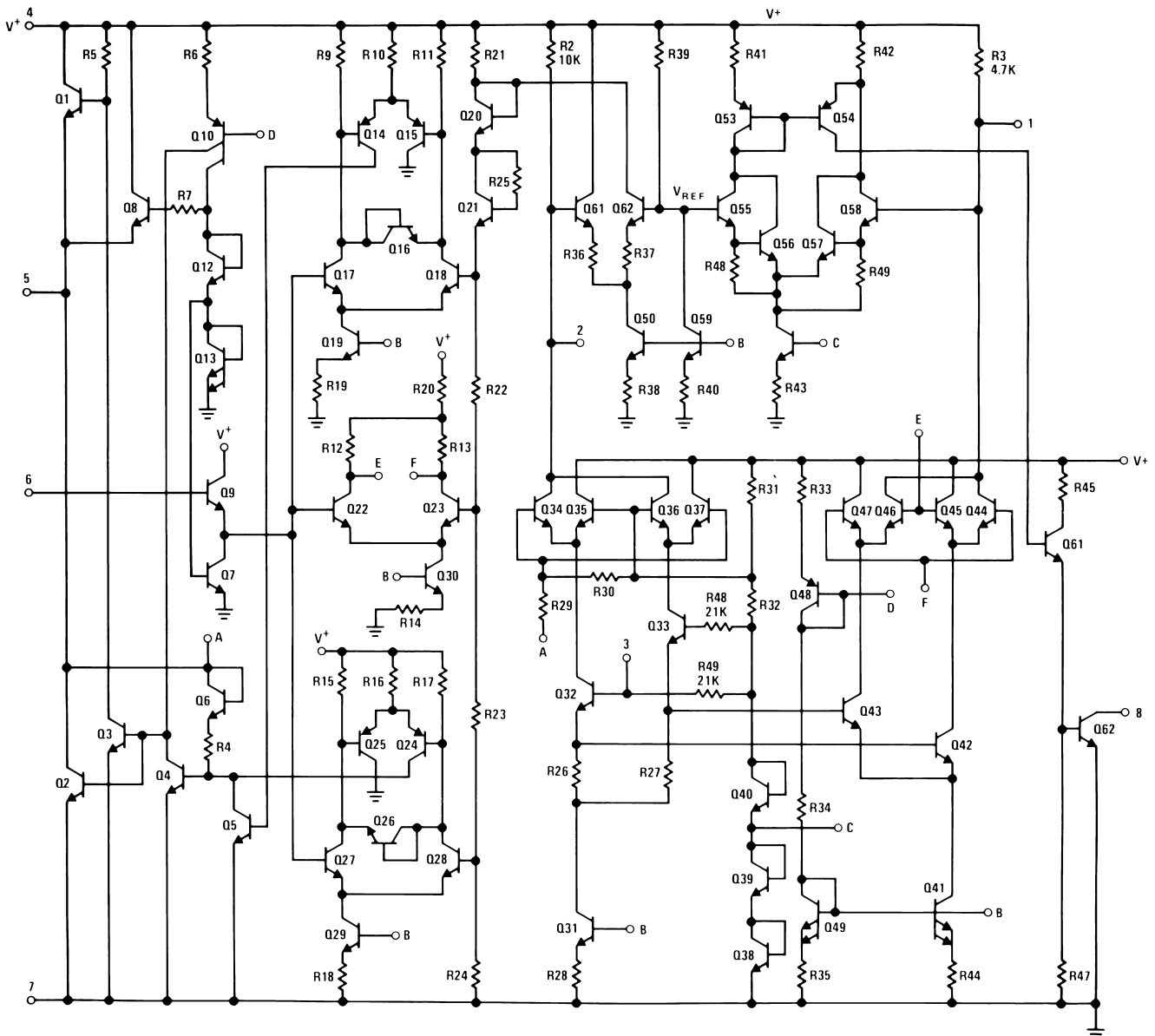

以上信息仅供参考. 如需帮助联系客服人员. 谢谢 XINLUDA

X-ON Electronics

Largest Supplier of Electrical and Electronic Components

Click to view similar products for [Audio DSPs](#) category:

Click to view products by [XINLUDA](#) manufacturer:

Other Similar products are found below :

[E-TDA7377A](#) [TDA7716N](#) [BR281W31A101V1G](#) [LC823425-12G1-LR-H](#) [TDA7419N](#) [R3910-CFAB-E1B](#) [HMC474MP86ETR](#)
[AMIS30660CANH6G](#) [B300W35A102XYG](#) [MAX9892ERT+T](#) [MAX9892ELTT](#) [SB3229-E1](#) [NJW1157BFC2](#) [ZL38060LDG1](#) [SB3231-E1](#)
[HMC1022-SX](#) [SA3229-E1-T](#) [LC75056PE-H](#) [TDA7729](#) [NJW1195AV](#) [WM5102ECS/R](#) [CI1103](#) [WM5102ECS/R](#) [100-CG1820](#) [CS48L10-](#)
[CNZ](#) [CS48L10-CNZR](#) [CS47024C-CQZ](#) [CS48L10-CWZR](#) [CS48L11-CNZ](#) [HMC618LP3ETR](#) [HMC604LP3ETR](#) [HMC5622LS7TR](#)
[HMC288MS8ETR](#) [HMC240A](#) [STA323W13TR](#) [BU9408KS2](#) [DSPB56725AF](#) [TAS3204PAGR](#) [ADAU1467WBCPZ300](#)
[ADAU1463WBCPZ300](#) [BD37514FS-E2](#) [ADAU1463WBCPZ150](#) [ADAU1466WBCPZ300](#) [NJM2294V-TE1](#) [LC823450TA-2H](#) [NJM2537V-](#)
[TE1](#) [TWL1103TPBSQ1](#) [LC823450XDTBG](#) [HMC-AUH312-SX](#) [ADAV4622BSTZ](#)