

description

74LS30 are characterized for operation from
 0°C to 70° C

FUNCTION TABLE

INPUTS A THRU H	OUTPUT Y
All inputs H	L
One or more inputs L	H

logic diagram

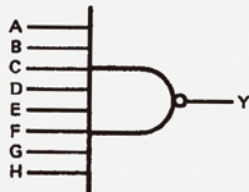

positive logic

$$Y = \overline{A \cdot B \cdot C \cdot D \cdot E \cdot F \cdot G \cdot H} \text{ or}$$

$$Y = \overline{A} + \overline{B} + \overline{C} + \overline{D} + \overline{E} + \overline{F} + \overline{G} + \overline{H}$$

logic symbol†

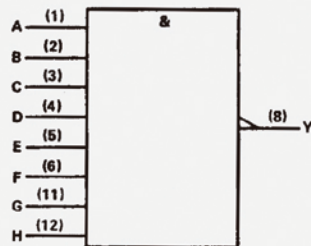

74LS30... J PACKAGE



74LS30... J PACKAGE

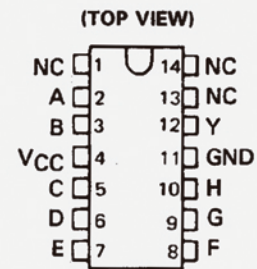

XD74LS30 DIP14 / XL74LS30 SOP14

schematics (each gate)

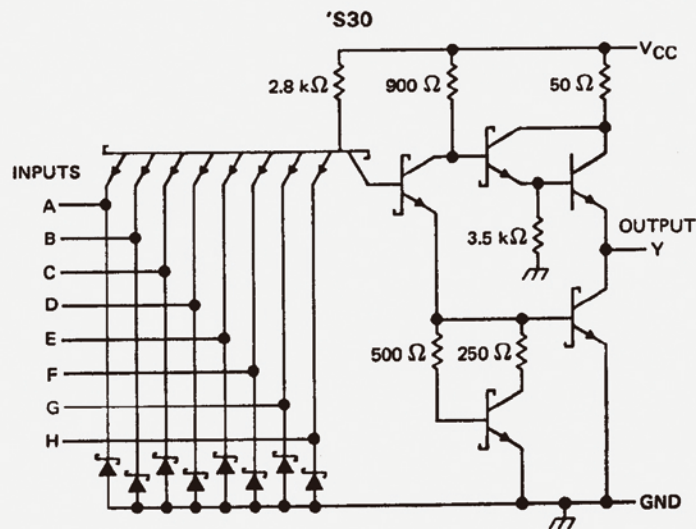
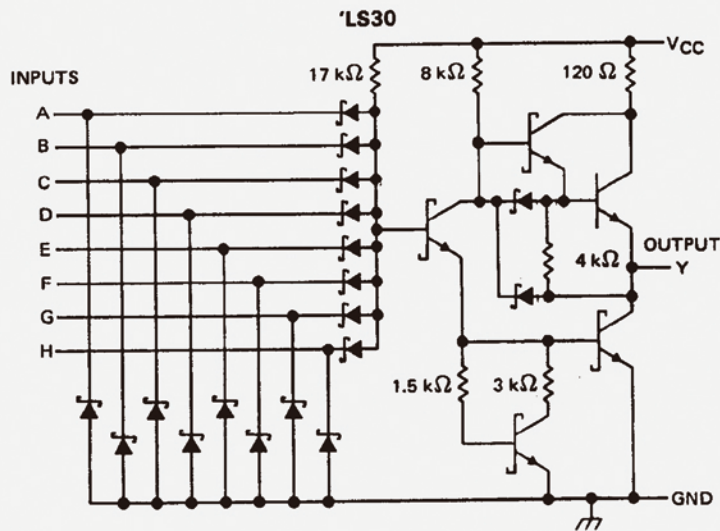
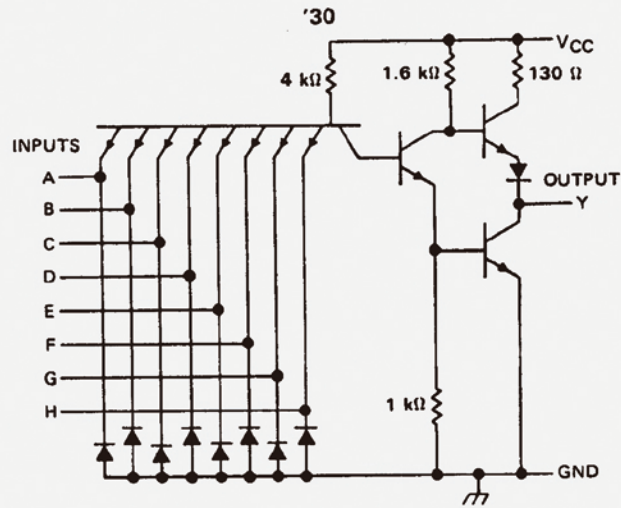

Resistor values shown are nominal.

XD74LS30 DIP14 / XL74LS30 SOP14

absolute maximum ratings over operating free-air temperature range (unless otherwise noted)

Supply voltage, V_{CC} (see Note 1)	7 V
Input voltage	5.5 V
Operating free-air temperature range: XD74LS30	-55°C to 125°C
XL74LS30	0°C to 70°C
Storage temperature range	-65°C to 150°C

NOTE 1: Voltage values are with respect to network ground terminal.

recommended operating conditions

	XD74LS30			XL74LS30			UNIT
	MIN	NOM	MAX	MIN	NOM	MAX	
V_{CC} Supply voltage	4.5	5	5.5	4.75	5	5.25	V
V_{IH} High-level input voltage	2			2			V
V_{IL} Low-level input voltage			0.8			0.8	V
I_{OH} High-level output current			-0.4			-0.4	mA
I_{OL} Low-level output current			16			16	mA
T_A Operating free-air temperature	-55		125	0		70	°C

electrical characteristics over recommended operating free-air temperature range (unless otherwise noted)

PARAMETER	TEST CONDITIONS †	XD74LS30			XL74LS30			UNIT
		MIN	TYP ‡	MAX	MIN	TYP ‡	MAX	
V_{IK}	$V_{CC} = \text{MIN}, I_I = -12 \text{ mA}$			-1.5			-1.5	V
V_{OH}	$V_{CC} = \text{MIN}, V_{IL} = 0.8 \text{ V}, I_{OH} = -0.4 \text{ mA}$	2.4	3.4		2.4	3.4		V
V_{OL}	$V_{CC} = \text{MIN}, V_{IH} = 2 \text{ V}, I_{OL} = 16 \text{ mA}$		0.2	0.4		0.2	0.4	V
I_I	$V_{CC} = \text{MAX}, V_I = 5.5 \text{ V}$			1			1	mA
I_{IH}	$V_{CC} = \text{MAX}, V_I = 2.4 \text{ V}$			40			40	µA
I_{IL}	$V_{CC} = \text{MAX}, V_I = 0.4 \text{ V}$			-1.6			-1.6	mA
$I_{OS} §$	$V_{CC} = \text{MAX}$	-20		-55	-18		-55	mA
I_{CCH}	$V_{CC} = \text{MAX}, V_I = 0$		1	2		1	2	mA
I_{CCL}	$V_{CC} = \text{MAX}, V_I = 4.5 \text{ V}$		3	6		3	6	mA

† For conditions shown as MIN or MAX, use the appropriate value specified under recommended operating conditions.

‡ All typical values are at $V_{CC} = 5 \text{ V}, T_A = 25^\circ\text{C}$.

§ Not more than one output should be shorted at a time.

switching characteristics, $V_{CC} = 5 \text{ V}, T_A = 25^\circ\text{C}$ (see note 2)

PARAMETER	FROM (INPUT)	TO (OUTPUT)	TEST CONDITIONS	MIN	TYP	MAX	UNIT
t_{PLH}	Any	Y	$R_L = 400 \Omega, C_L = 15 \text{ pF}$		13	22	ns
t_{PHL}					8	15	ns

NOTE 2: Load circuits and voltage waveforms are shown in Section 1.

XD74LS30 DIP14 / XL74LS30 SOP14

absolute maximum ratings over operating free-air temperature range (unless otherwise noted)

Supply voltage, V_{CC} (see Note 1)	7 V
Input voltage	7 V
Operating free-air temperature range: XD74LS30	-55°C to 125°C
XL74LS30	0°C to 70°C
Storage temperature range	-65°C to 150°C

NOTE 1: Voltage values are with respect to network ground terminal.

recommended operating conditions

	XD74LS30			XL74LS30			UNIT
	MIN	NOM	MAX	MIN	NOM	MAX	
V_{CC} Supply voltage	4.5	5	5.5	4.75	5	5.25	V
V_{IH} High-level input voltage	2			2			V
V_{IL} Low-level input voltage			0.7			0.8	V
I_{OH} High-level output current			-0.4			-0.4	mA
I_{OL} Low-level output current			4			8	mA
T_A Operating free-air temperature	-55		125	0		70	°C

electrical characteristics over recommended operating free-air temperature range (unless otherwise noted)

PARAMETER	TEST CONDITIONS †	XD74LS30			XL74LS30			UNIT
		MIN	TYP‡	MAX	MIN	TYP‡	MAX	
V_{IK}	$V_{CC} = \text{MIN}, I_I = -18 \text{ mA}$			-1.5			-1.5	V
V_{OH}	$V_{CC} = \text{MIN}, V_{IL} = \text{MAX}, I_{OH} = -0.4 \text{ mA}$	2.5	3.4		2.7	3.4		V
V_{OL}	$V_{CC} = \text{MIN}, V_{IH} = 2 \text{ V}, I_{OL} = 4 \text{ mA}$		0.25	0.4			0.4	V
	$V_{CC} = \text{MIN}, V_{IH} = 2 \text{ V}, I_{OL} = 8 \text{ mA}$					0.25	0.5	
I_I	$V_{CC} = \text{MAX}, V_I = 7 \text{ V}$			0.1			0.1	mA
I_{IH}	$V_{CC} = \text{MAX}, V_I = 2.7 \text{ V}$			20			20	μA
I_{IL}	$V_{CC} = \text{MAX}, V_I = 0.4 \text{ V}$			-0.4			-0.4	mA
$I_{OS}§$	$V_{CC} = \text{MAX}$	-20		-100	-20		-100	mA
I_{CCH}	$V_{CC} = \text{MAX}, V_I = 0$		0.35	0.5		0.35	0.5	mA
I_{CCL}	$V_{CC} = \text{MAX}, V_I = 4.5 \text{ V}$		0.6	1.1		0.6	1.1	mA

† For conditions shown as MIN or MAX, use the appropriate value specified under recommended operating conditions.

‡ All typical values are at $V_{CC} = 5 \text{ V}, T_A = 25^\circ\text{C}$

§ Not more than one output should be shorted at a time, and the duration of the short-circuit should not exceed one second.

switching characteristics, $V_{CC} = 5 \text{ V}, T_A = 25^\circ\text{C}$ (see note 2)

PARAMETER	FROM (INPUT)	TO (OUTPUT)	TEST CONDITIONS	MIN	TYP	MAX	UNIT
t_{PLH}	Any	Y	$R_L = 2 \text{ k}\Omega, C_L = 15 \text{ pF}$		8	15	ns
t_{PHL}					13	20	ns

NOTE 2: Load circuits and voltage waveforms are shown in Section 1.

XD74LS30 DIP14 / XL74LS30 SOP14

absolute maximum ratings over operating free-air temperature range (unless otherwise noted)

Supply voltage, V_{CC} (see Note 1)	7 V
Input voltage	5.5 V
Operating free-air temperature range: XD74LS30	-55°C to 125°C
XL74LS30	0°C to 70°C
Storage temperature range	-65°C to 150°C

NOTE 1: Voltage values are with respect to network ground terminal.

recommended operating conditions

	XD74LS30			XL74LS30			UNIT
	MIN	NOM	MAX	MIN	NOM	MAX	
V_{CC} Supply voltage	4.5	5	5.5	4.75	5	5.25	V
V_{IH} High-level input voltage	2			2			V
V_{IL} Low-level input voltage			0.8			0.8	V
I_{OH} High-level output current			-1			-1	mA
I_{OL} Low-level output current			20			20	mA
T_A Operating free-air temperature	-55		125	0		70	°C

electrical characteristics over recommended operating free-air temperature range (unless otherwise noted)

PARAMETER	TEST CONDITIONS †	XD74LS30			XL74LS30			UNIT
		MIN	TYP‡	MAX	MIN	TYP‡	MAX	
V_{IK}	$V_{CC} = \text{MIN}, I_I = -18 \text{ mA}$			-1.2			-1.2	V
V_{OH}	$V_{CC} = \text{MIN}, V_{IL} = 0.8 \text{ V}, I_{OH} = -1 \text{ mA}$	2.5	3.4		2.7	3.4		V
V_{OL}	$V_{CC} = \text{MIN}, V_{IH} = 2 \text{ V}, I_{OL} = 20 \text{ mA}$			0.5			0.5	V
I_I	$V_{CC} = \text{MAX}, V_I = 5.5 \text{ V}$			1			1	mA
I_{IH}	$V_{CC} = \text{MAX}, V_I = 2.7 \text{ V}$			50			50	µA
I_{IL}	$V_{CC} = \text{MAX}, V_I = 0.5 \text{ V}$			-2			-2	mA
$I_{OS} §$	$V_{CC} = \text{MAX}$	-40		-100	-40		-100	mA
I_{CCH}	$V_{CC} = \text{MAX}, V_I = 0$		3	5		3	5	mA
I_{CCL}	$V_{CC} = \text{MAX}, V_I = 4.5 \text{ V}$		5.5	10		5.5	10	mA

† For conditions shown as MIN or MAX, use the appropriate value specified under recommended operating conditions.

‡ All typical values are at $V_{CC} = 5 \text{ V}, T_A = 25^\circ\text{C}$.

§ Not more than one output should be shorted at a time, and the duration of the short-circuit should not exceed one second.

switching characteristics, $V_{CC} = 5 \text{ V}, T_A = 25^\circ\text{C}$ (see note 2)

PARAMETER	FROM (INPUT)	TO (OUTPUT)	TEST CONDITIONS	MIN	TYP	MAX	UNIT
t_{PLH}	Any	Y	$R_L = 280 \Omega, C_L = 15 \text{ pF}$		4	6	ns
t_{PHL}					4.5	7	ns
t_{PLH}			$R_L = 280 \Omega, C_L = 50 \text{ pF}$		5.5		ns
t_{PHL}					6.5		ns

NOTE 2: Load circuits and voltage waveforms are shown in Section 1.

以上信息仅供参考. 如需帮助联系客服人员。谢谢 XINLUDA

X-ON Electronics

Largest Supplier of Electrical and Electronic Components

Click to view similar products for [Inverters](#) category:

Click to view products by [XINLUDA](#) manufacturer:

Other Similar products are found below :

[5962-8550101CA](#) [E5-652Z](#) [NL17SGU04P5T5G](#) [NLX2G04BMX1TCG](#) [412327H](#) [022413E](#) [NL17SG14AMUTCG](#) [NLU2G04AMUTCG](#)
[NLU2GU04BMX1TCG](#) [NLV14049UBDR2G](#) [NLV14069UBDTR2G](#) [NLV17SZ14DFT2G](#) [NLVVHC1G05DFT2G](#) [74LVC2G17FW4-7](#)
[NLU2G04CMX1TCG](#) [NLV17SZ06DFT2G](#) [NLV27WZ04DFT2G](#) [NLV74HCT14ADTR2G](#) [NLX2G14CMUTCG](#) [NLU1G04AMX1TCG](#)
[SNJ54ACT14W](#) [SNJ54AC04W](#) [NCV1729SN35T1G](#) [TC74VHC04FK\(EL,K\)](#) [NLV74HC04ADTR2G](#) [NLV17SZ04DFT2G](#) [74AUP2G04FW3-](#)
[7](#) [NLU1G04AMUTCG](#) [NLX2G04CMUTCG](#) [NLX2G04AMUTCG](#) [NLV74ACT00DR2G](#) [NLV74AC14DR2G](#) [NLV37WZ14USG](#)
[NLV27WZ04DFT1G](#) [NLV14106BDG](#) [NLU1GU04CMUTCG](#) [NLU1GT14AMUTCG](#) [NLU1G04CMUTCG](#) [NL17SZU04P5T5G](#)
[NL17SG14DFT2G](#) [74LVC06ADTR2G](#) [74LVC04ADR2G](#) [TC7SZ04AFS,L3J](#) [NLU1GT04AMUTCG](#) [NLV37WZ04USG](#)
[NLX3G14FMUTCG](#) [NL17SZ04P5T5G](#) [NL17SG14P5T5G](#) [NLV27WZU04DFT2G](#) [LV0008G100-4EOFN](#)