

Super Voltage Converters

The XD/XL7660 Super Voltage Converters are monolithic CMOS voltage conversion ICs that guarantee significant performance advantages over other similar devices. They are direct replacements for the industry standard XD7660 offering an **extended** operating supply voltage range up to 12V, with **lower** supply current. A **Frequency Boost pin** has been incorporated to enable the user to achieve lower output impedance despite using smaller capacitors. All improvements are highlighted in the “Electrical Specifications” section on page 3. **Critical parameters are guaranteed over the entire commercial and industrial temperature ranges.**

The XD/XL7660 perform supply voltage conversions from positive to negative for an input range of 1.5V to 12V, resulting in complementary output voltages of -1.5V to -12V. Only two non-critical external capacitors are needed, for the charge pump and charge reservoir functions. The XD/XL7660 can be connected to function as a voltage doubler and will generate up to 22.8V with a 12V input. They can also be used as a voltage multipliers or voltage dividers.

Each chip contains a series DC power supply regulator, RC oscillator, voltage level translator, and four output power MOS switches. The oscillator, when unloaded, oscillates at a nominal frequency of 10kHz for an input supply voltage of 5.0V. This frequency can be lowered by the addition of an external capacitor to the “OSC” terminal, or the oscillator may be over-driven by an external clock.

The “LV” terminal may be tied to GND to bypass the internal series regulator and improve low voltage (LV) operation. At medium to high voltages (3.5V to 12V), the LV pin is left floating to prevent device latchup.

In some applications, an external Schottky diode from V_{OUT} to CAP- is needed to guarantee latchup free operation (see Do’s and Dont’s section on page 8).

Pin Configurations

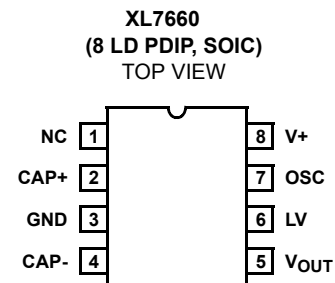
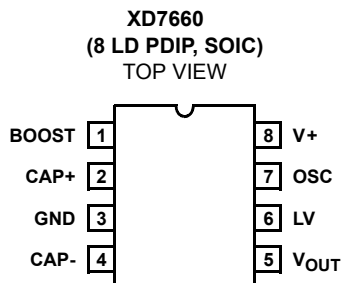

Features

- Guaranteed Lower Max Supply Current for All Temperature Ranges
- Wide Operating Voltage Range: 1.5V to 12V
- 100% Tested at 3V
- Boost Pin (Pin 1) for Higher Switching Frequency
- Guaranteed Minimum Power Efficiency of 96%
- Improved Minimum Open Circuit Voltage Conversion Efficiency of 99%
- Improved SCR Latchup Protection
- Simple Conversion of +5V Logic Supply to ±5V Supplies
- Simple Voltage Multiplication $V_{OUT} = (-)nV_{IN}$
- Easy to Use; Requires Only Two External Non-Critical Passive Components
- Improved Direct Replacement for Industry Standard XD7660 and Other Second Source Devices
- Pb-Free Available (RoHS Compliant)

Applications

- Simple Conversion of +5V to ±5V Supplies
- Voltage Multiplication $V_{OUT} = \pm nV_{IN}$
- Negative Supplies for Data Acquisition Systems and Instrumentation
- RS232 Power Supplies
- Supply Splitter, $V_{OUT} = \pm V_S$

XD7660 DIP8 / XL7660 SOP8

Absolute Maximum Ratings

Supply Voltage	+13.0V
LV and OSC Input Voltage (Note 5)	
V+ < 5.5V	-0.3V to V+ + 0.3V
V+ > 5.5V	V+ -5.5V to V+ +0.3V
Current into LV (Note 5)	
V+ > 3.5V	.20μA
Output Short Duration	
V _{SUPPLY} ≤ 5.5V	Continuous

Operating Conditions

Temperature Range	
XD/XL7660	-40°C to +85°C
7660	0°C to +70°C

CAUTION: Do not operate at or near the maximum ratings listed for extended periods of time. Exposure to such conditions may adversely impact product reliability and result in failures not covered by warranty.

NOTES:

5. Connecting any terminal to voltages greater than V+ or less than GND may cause destructive latchup. It is recommended that no inputs from sources operating from external supplies be applied prior to "power up" of XD/XL7660
6. θ_{JA} is measured with the component mounted on a low effective thermal conductivity test board in free air. See Tech Brief [TB379](#) for details.
7. For θ_{JC} , the "case temp" location is taken at the package top center.
8. Pb-free PDIPs can be used for through-hole wave solder processing only. They are not intended for use in reflow solder processing applications.

Electrical Specifications XD/XL7660, V+ = 5V, T_A = +25°C, OSC = Free running (see Figure 12, "XD7660 Test Circuit" on page 7 and Figure 13 "XL7660 Test Circuit" on page 7), unless otherwise specified.

PARAMETER	SYMBOL	TEST CONDITIONS	MIN (Note 9)	TYP	MAX (Note 9)	UNITS
Supply Current (Note 11)	I+	R _L = ∞, +25°C	-	80	160	μA
		0°C < T _A < +70°C	-	-	180	μA
		-40°C < T _A < +85°C	-	-	180	μA
		-55°C < T _A < +125°C	-	-	200	μA
Supply Voltage Range - High (Note 12)	V _{+H}	R _L = 10k, LV Open, T _{MIN} < T _A < T _{MAX}	3.0	-	12	V
Supply Voltage Range - Low	V _{+L}	R _L = 10k, LV to GND, T _{MIN} < T _A < T _{MAX}	1.5	-	3.5	V
Output Source Resistance	R _{OUT}	I _{OUT} = 20mA	-	60	100	Ω
		I _{OUT} = 20mA, 0°C < T _A < +70°C	-	-	120	Ω
		I _{OUT} = 20mA, -25°C < T _A < +85°C	-	-	120	Ω
		I _{OUT} = 20mA, -55°C < T _A < +125°C	-	-	150	Ω
		I _{OUT} = 3mA, V+ = 2V, LV = GND, 0°C < T _A < +70°C	-	-	250	Ω
		I _{OUT} = 3mA, V+ = 2V, LV = GND, -40°C < T _A < +85°C	-	-	300	Ω
Oscillator Frequency (Note 10)	f _{OSC}	C _{OSC} = 0, Pin 1 Open or GND	5	10	-	kHz
		C _{OSC} = 0, Pin 1 = V+	-	35	-	kHz
Power Efficiency	P _{EFF}	R _L = 5kΩ	96	98	-	%
		T _{MIN} < T _A < T _{MAX} R _L = 5kΩ	95	97	-	-
Voltage Conversion Efficiency	V _{OUTEFF}	R _L = ∞	99	99.9	-	%

XD7660 DIP8 / XL7660 SOP8

Electrical Specifications XD/XL7660, V+ = 5V, T_A = +25°C, OSC = Free running (see Figure 12, "XD7660 Test Circuit" on page 7 and Figure 13 "XL7660 Test Circuit" on page 7), unless otherwise specified. **(Continued)**

PARAMETER	SYMBOL	TEST CONDITIONS	MIN (Note 9)	TYP	MAX (Note 9)	UNITS
Oscillator Impedance	Z _{OSC}	V+ = 2V	-	1	-	MΩ
		V+ = 5V	-	100	-	kΩ
XD/XL7660, V+ = 3V, T_A = 25°C, OSC = Free running, Test Circuit Figure 13, unless otherwise specified						
Supply Current (Note 13)	I+	V+ = 3V, R _L = ∞, +25°C	-	26	100	μA
		0°C < T _A < +70°C	-	-	125	μA
		-40°C < T _A < +85°C	-	-	125	μA
Output Source Resistance	R _{OUT}	V+ = 3V, I _{OUT} = 10mA	-	97	150	Ω
		0°C < T _A < +70°C	-	-	200	Ω
		-40°C < T _A < +85°C	-	-	200	Ω
Oscillator Frequency (Note 13)	f _{OSC}	V+ = 3V (same as 5V conditions)	5.0	8	-	kHz
		0°C < T _A < +70°C	3.0	-	-	kHz
		-40°C < T _A < +85°C	3.0	-	-	kHz

NOTES:

9. Parameters with MIN and/or MAX limits are 100% tested at +25°C, unless otherwise specified. Temperature limits established by characterization and are not production tested.
10. In the test circuit, there is no external capacitor applied to pin 7. However, when the device is plugged into a test socket, there is usually a very small but finite stray capacitance present, on the order of 5pF.
11. The Intersil XD/XL7660 can operate without an external diode over the full temperature and voltage range. This device will function in existing designs that incorporate an external diode with no degradation in overall circuit performance.
12. All significant improvements over the industry standard XD7660 are highlighted.
13. Derate linearly above 50°C by 5.5mW/°C.

Functional Block Diagram

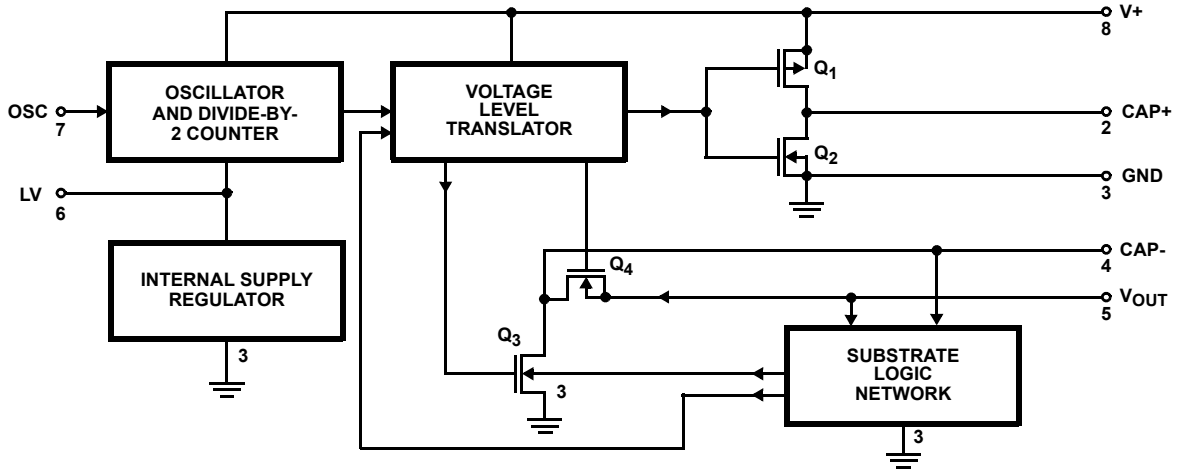

Typical Performance Curves

See Figure 12, "XD7660 Test Circuit" on page 7) and Figure 13 "XL7660 Test Circuit" on page 7

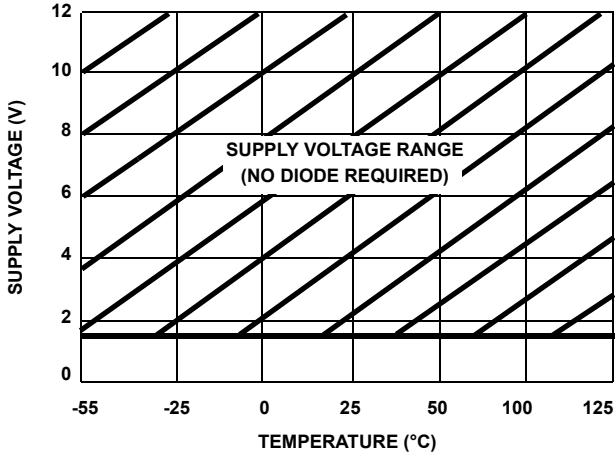

FIGURE 1. OPERATING VOLTAGE AS A FUNCTION OF TEMPERATURE

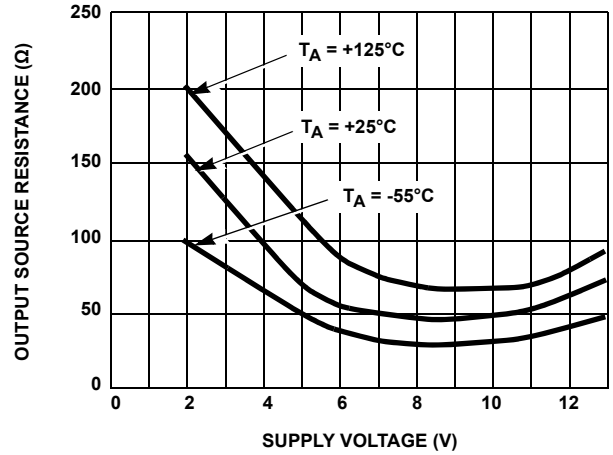

FIGURE 2. OUTPUT SOURCE RESISTANCE AS A FUNCTION OF SUPPLY VOLTAGE

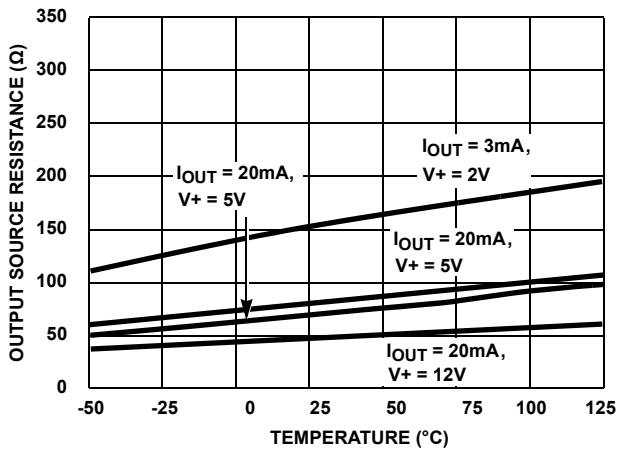

FIGURE 3. OUTPUT SOURCE RESISTANCE AS A FUNCTION OF TEMPERATURE

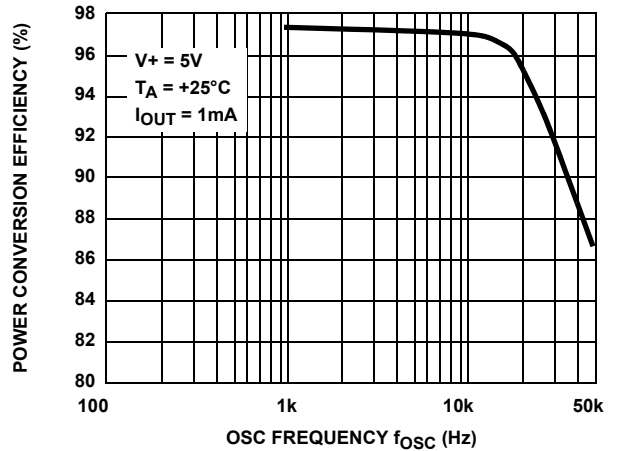

FIGURE 4. POWER CONVERSION EFFICIENCY AS A FUNCTION OF OSCILLATOR FREQUENCY

Typical Performance Curves

See Figure 12, "XD7660 Test Circuit" on page 7) and Figure 13 "XL7660 Test Circuit" on page 7 (Continued)

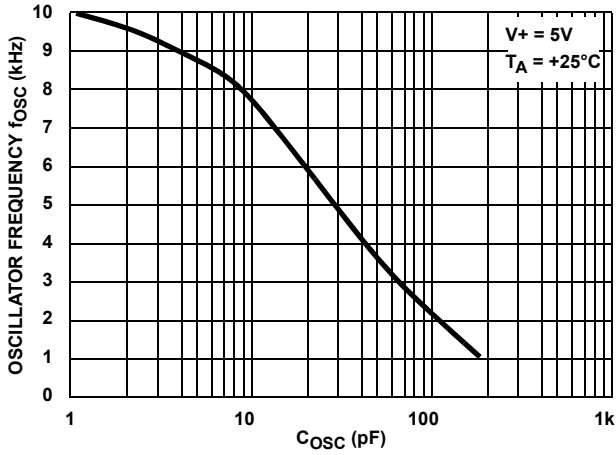

FIGURE 5. FREQUENCY OF OSCILLATION AS A FUNCTION OF EXTERNAL OSCILLATOR CAPACITANCE

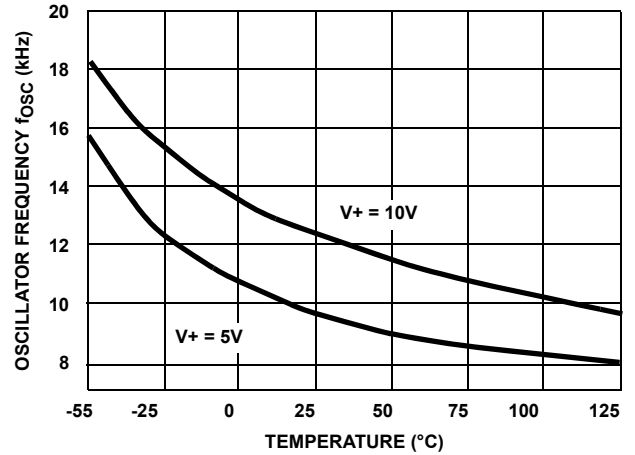

FIGURE 6. UNLOADED OSCILLATOR FREQUENCY AS A FUNCTION OF TEMPERATURE

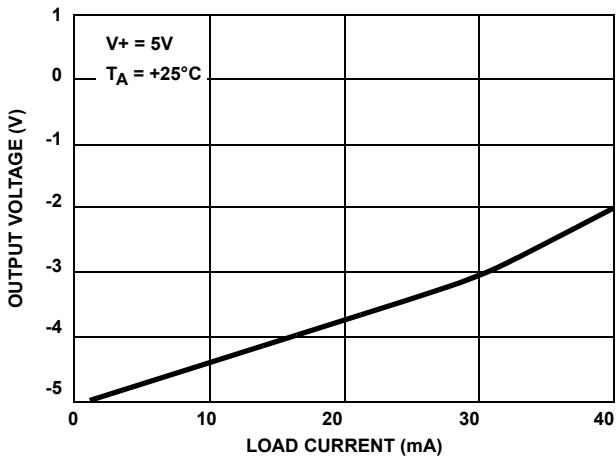

FIGURE 7. OUTPUT VOLTAGE AS A FUNCTION OF OUTPUT CURRENT

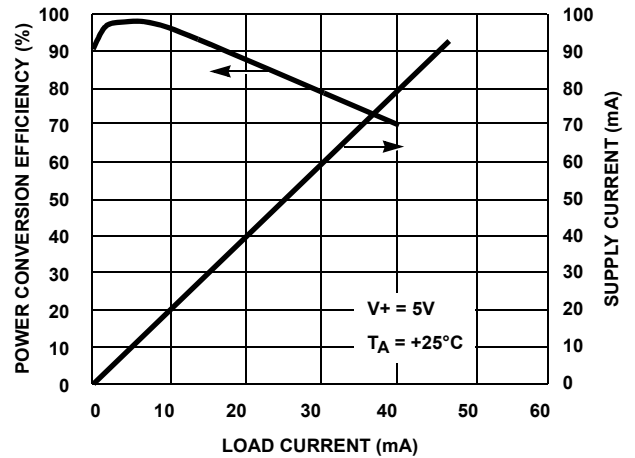

FIGURE 8. SUPPLY CURRENT AND POWER CONVERSION EFFICIENCY AS A FUNCTION OF LOAD CURRENT

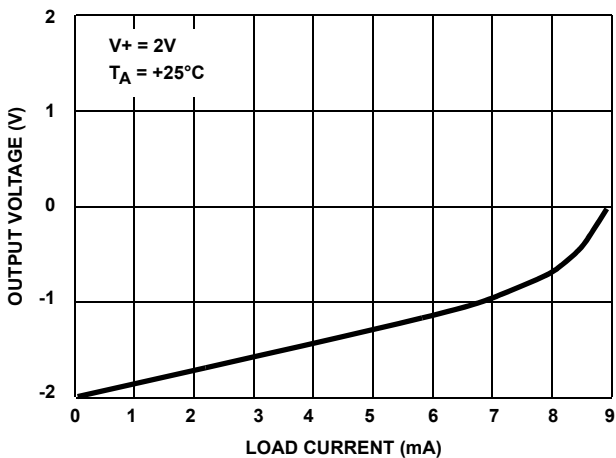

FIGURE 9. OUTPUT VOLTAGE AS A FUNCTION OF OUTPUT CURRENT

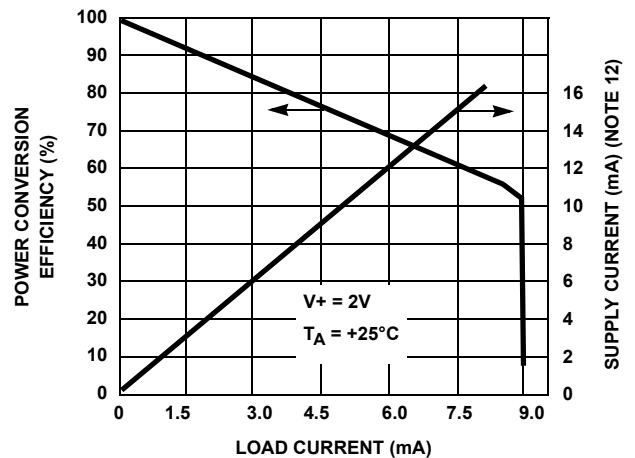

FIGURE 10. SUPPLY CURRENT AND POWER CONVERSION EFFICIENCY AS A FUNCTION OF LOAD CURRENT

Typical Performance Curves

See Figure 12, "XD7660 Test Circuit" on page 7) and Figure 13 "XL7660 Test Circuit" on page 7 (Continued)

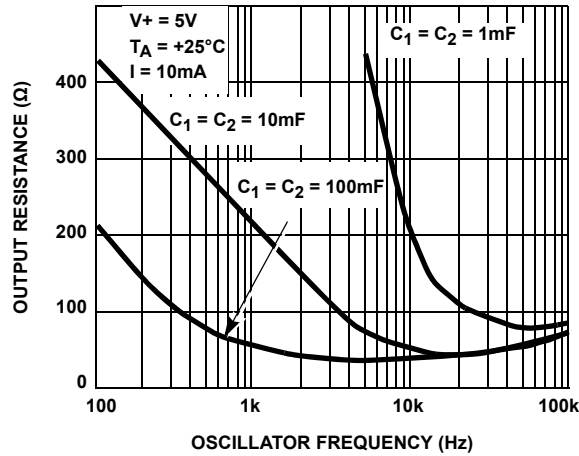
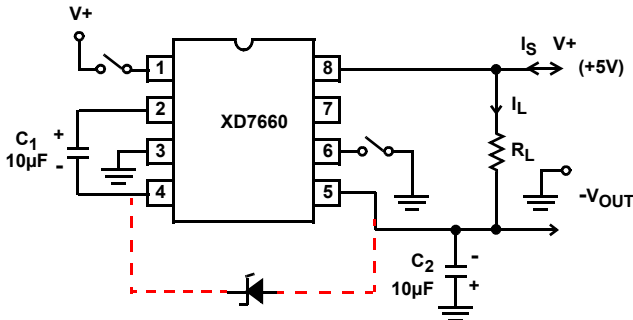

FIGURE 11. OUTPUT SOURCE RESISTANCE AS A FUNCTION OF OSCILLATOR FREQUENCY

NOTE:

14. These curves include, in the supply current, that current fed directly into the load R_L from the V^+ (see Figure 12). Thus, approximately half the supply current goes directly to the positive side of the load, and the other half, through the XD/XL7660, goes to the negative side of the load. Ideally, $V_{OUT} \approx 2V_{IN}$, $I_S \approx 2I_L$, so $V_{IN} \times I_S \approx V_{OUT} \times I_L$.



NOTE: For large values of C_{OSC} ($>1000pF$), the values of C_1 and C_2 should be increased to $100\mu F$.

FIGURE 12.XD7660 TEST CIRCUIT

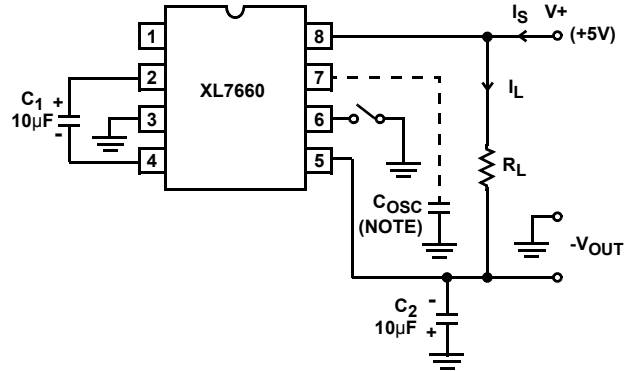

NOTE: For large values of C_{OSC} ($>1000pF$) the values of C_1 and C_2 should be increased to $100\mu F$.

FIGURE 13.XL7660 TEST CIRCUIT

X-ON Electronics

Largest Supplier of Electrical and Electronic Components

Click to view similar products for [Isolated DC/DC Converters](#) category:

Click to view products by [XINLUDA](#) manufacturer:

Other Similar products are found below :

[ESM6D044440C05AAQ](#) [FMD15.24G](#) [PSL486-7LR](#) [PSR152.5-7IR](#) [Q48T30020-NBB0](#) [AVO240-48S12B-6L](#) [AVO250-48S28B-6L](#) [NAN-0505](#) [HW-L16D](#) [JAHW100Y1](#) [217-1617-001](#) [22827](#) [SPB05C-12](#) [SQ24S15033-PS0S](#) [18952](#) [19-130041](#) [CE-1003](#) [CE-1004](#) [GQ2541-7R](#) [PSE1000DCDC-12V](#) [RDS180245](#) [MAU228](#) [419-2065-201](#) [449-2075-101](#) [J80-0041NL](#) [V300C24C150BG](#) [419-2062-200](#) [419-2063-401](#) [419-2067-101](#) [419-2067-501](#) [419-2068-001](#) [DCG40-5G](#) [DFC15U48D15](#) [449-2067-000](#) [XGS-0512](#) [XGS-1205](#) [XGS-1212](#) [XGS-2412](#) [XGS-2415](#) [XKS-1215](#) [033456](#) [NCT1000N040R050B](#) [SPB05B-15](#) [SPB05C-15](#) [SSQE48T25025-NAA0G](#) [L-DA20](#) [HP3040-9RG](#) [HP1001-9RTG](#) [XKS-2415](#) [XKS-2412](#)