

### 1 Watt

- 5V and 12V Input Models
- Precision Voltage Regulated
- Output Voltages from 100V to 2000V
- 0 to 100% Programmable Output
- On-board Voltage Reference
- Operating Temperature -10°C to +50°C
- <25ppm/°C Temperature Coefficient
- Shielded Case with Isolated Case Ground
- Ultra Low Ripple, down to 5ppm
- 3 Year Warranty



#### Dimensions:

CA Series: 1.75 x 1.11 x 0.50" (44.45 x 28.29 x 12.70mm)

#### Key Applications:

- Photo Multiplier Tube
- Solid State Detectors
- Avalanche Photodiodes
- Electrophoresis
- Piezo Devices
- Capacitor Charging
- EO Lenses

The CA Series is a high performance, precision regulated, high voltage converter with high stability and low ripple, along with a built-in voltage monitor output and an on-board precision voltage reference. Each model is programmed from 0 to 100% of rated output via a DAC compatible high impedance programming input. The voltage reference can be used to drive the high voltage output at 100% or to adjust the output with an external potentiometer or voltage divider. The output voltage monitor is internally buffered to provide a low impedance (up to 1 mA) signal to external circuitry. A quasi-sinewave oscillator, internal transformer shielding, and an isolated steel case reduce EMI/RFI radiation to extremely low levels.

A proprietary encapsulation process and custom 94 V-0 listed, high performance formula are used to achieve excellent high voltage and thermal properties. CM Series Mounting Kits are available separately and can be used to convert any CA Series unit into a chassis mount solution with high voltage connectors.

### Input

12Vin Models					
Characteristic	Minimum	Typical	Maximum	Units	Notes & Conditions
Input Voltage, Vin	11.5	12.0	15.5	VDC	For 12Vin models
Input Current, No Load			80	mA	200V-1200V
Input Current, No Load			100	mA	2kV
Input Current, Full Load			220	mA	All Output Voltages
Programming Voltage, Vpgm	0		5	VDC	<150µA

5Vin Models					
Characteristic	Minimum	Typical	Maximum	Units	Notes & Conditions
Input Voltage, Vin	4.75	5	5.25	VDC	For 5Vin models
Input Current, No Load			65	mA	200V-1200V
Input Current, No Load			155	mA	2kV
Input Current, Full Load			420	mA	200V-1200V
Input Current, Full Load			550	mA	2kV
Programming Voltage, Vpgm	0		2.048	VDC	<150µA

### Output

Characteristic	Minimum	Typical	Maximum	Units	Notes & Conditions
Output Voltage			2000	VDC	See Models and Ratings Table
Output Current			5	mA	See Models and Ratings Table
Output Programming	0		100	%	
Setpoint Accuracy <sup>(4)</sup>		±1		%	
Gain Adjust <sup>(5)</sup>		±1		%	Potentiometer
Linearity <sup>(6)</sup>			±0.5	%	From 15% to 100% Vout
Minimum Load	No minimum load required				
Line Regulation	0.001		0.01	%	Conditions: 100% Vpgm, Full Load
Load Regulation	0.001		0.05	%	No Load to Full Load at 100% Vpgm, Nominal Vin.
Short Circuit Protection	1			min	
Ripple and Noise	0.0005		0.01	%	1MHz bandwidth
Temperature Coefficient		25		ppm/°C	
Stability			50	ppm/hr	
Voltage Monitor Output	0		Max Vpgm	VDC	Range corresponds to 0 to 100% Vout
Voltage Reference Output		Max Vpgm			Vref is a fixed output equal to Max Vpgm

### General

Characteristic	Minimum	Typical	Maximum	Units	Notes & Conditions
Isolation	N/A – Input ground is connected to output ground				
Construction	Case materials is zinc plated steel. UL 94 V-0 rated solid vacuum encapsulation				
Switching Frequency	45		400	kHz	
Mean Time Between Failure	2.1			MHrs	Per Bellcore TR 332 GB +25°C

### Environmental

Characteristic	Minimum	Typical	Maximum	Units	Notes & Conditions
Operating Temperature	-10		+50	°C	Case temperature
Storage Temperature	-25		+95	°C	
Humidity			95	%RH	Non-condensing
Cooling					Natural convection
Thermal Shock Limit			1	°C/10secc	

### Safety Approvals

Safety Agency	Safety Standard	Notes & Conditions
UL	IEC/UL/EN62368	
CE	CE Directive: RoHS and LVD	Where applicable
RoHS	RoHS 2 and 3 Directive (2011/65/EU)	Where applicable

### Notes

1. Maximum rated output current is available from 100% Max Vout down to 50% Max Vout, then derates linearly from 50% Max Vout down to zero.
2. Specifications after 1 hour warm-up, full load, 25°C unless otherwise indicated.
3. Proper thermal management techniques are required to maintain safe case temperature.
4. SET POINT ACCURACY refers to the ability of the unit to accurately deliver the programmed voltage.
5. GAIN ADJUST refers to the ability to alter the gain of the circuit to allow for set-point accuracy error.
6. LINEARITY refers to how much the transfer function can deviate from a straight line in the absence of any set-point error.

### Models & Ratings

Output Voltage	Output Current <sup>(1)</sup>	Regulation		Ripple	Frequency	Input Voltage	Model Number
		Load	Line				
0 to -200V	5mA	<0.05%	<0.01%	<0.01%	80-230kHz	12V	CA02N
0 to -200V	5mA	<0.005%	<0.003%	<0.01%	100-250kHz	5V	CA02N-5
0 to +200V	5mA	<0.05%	<0.01%	<0.01%	80-180kHz	12V	CA02P
0 to +200V	5mA	<0.01%	<0.01%	<0.01%	100-250kHz	5V	CA02P-5
0 to -500V	2mA	<0.01%	<0.01%	<0.01%	100-250kHz	12V	CA05N
0 to -500V	2mA	<0.005%	<0.002%	<0.005%	87-350kHz	5V	CA05N-5
0 to +500V	2mA	<0.01%	<0.01%	<0.01%	200-400kHz	12V	CA05P
0 to +500V	2mA	<0.003%	<0.002%	<0.005%	100-250kHz	5V	CA05P-5
0 to -1000V	1mA	<0.005%	<0.001%	<0.001%	100-250kHz	12V	CA10N
0 to -1000V	1mA	<0.005%	<0.001%	<0.001%	100-250kHz	5V	CA10N-5
0 to +1000V	1mA	<0.005%	<0.001%	<0.001%	80-250kHz	12V	CA10P
0 to +1000V	1mA	<0.005%	<0.001%	<0.001%	80-250kHz	12V	CA10PR
0 to +1000V	1mA	<0.005%	<0.001%	<0.001%	100-250kHz	5V	CA10P-5
0 to -1250V	0.8mA	<0.005%	<0.001%	<0.0005%	80-250kHz	12V	CA12N
0 to -1250V	0.8mA	<0.005%	<0.001%	<0.001%	150-300kHz	5V	CA12N-5
0 to +1250V	0.8mA	<0.005%	<0.001%	<0.0005%	80-250kHz	12V	CA12P
0 to +1250V	0.8mA	<0.005%	<0.001%	<0.001%	150-300kHz	5V	CA12P-5
0 to -2000V	0.5mA	<0.01%	<0.01%	<0.001%	100-250kHz	12V	CA20N
0 to -2000V	0.5mA	<0.001%	<0.001%	<0.001%	100-250kHz	5V	CA20N-5
0 to +2000V	0.5mA	<0.01%	<0.01%	<0.001%	80-250kHz	12V	CA20P
0 to +2000V	0.5mA	<0.005%	<0.003%	<0.001%	45-250kHz	5V	CA20P-5

### Mechanical Details

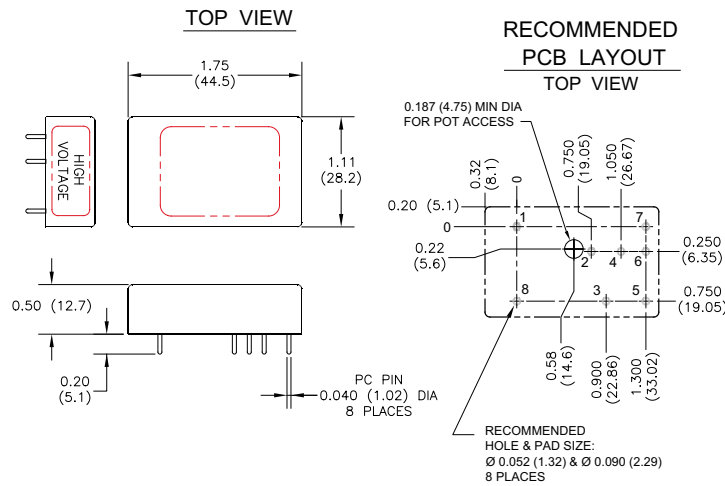

Pin	Function	Description	5Vin	12Vin
1	VOUT	High Voltage Output	Ground to Pin 8	
2	VPGM	Voltage Programming Input, <150uA	0 to +2.048V	0 to +5V
3	SGND	Signal Ground [For VPGM, VIN, VMON]	Low Voltage Ground	
4	VREF	Voltage Reference Output, +/- 1% , 1 mA	+2.048V	+5V
5	CGND	Case Ground	Case Ground	
6	VIN	Input Voltage	+4.75 to +5.25V	+11.5V to +15.5V
7	VMON	Voltage Monitor Output, 1mA, scales to 0 to 100% Vout	0 to +2.048V	0 to +5V
8	HV RTN	HV Output Return	Ground for Pin 1	

### Notes

- All dimensions are in inches (mm)
- Weight: 1.4oz (39.6g)
- Tolerance: X.XX±0.02 (0.51)
- Pin Tolerance: ±0.005 (0.127)
- All grounds internally connected except case. Case Ground (Pin5) must be connected to ground, with no more than 50V between case ground (Pin 5) and circuit ground (Pin 3).
- On negative output models, voltage monitor is buffered representation of programming voltage.

## Block Diagram

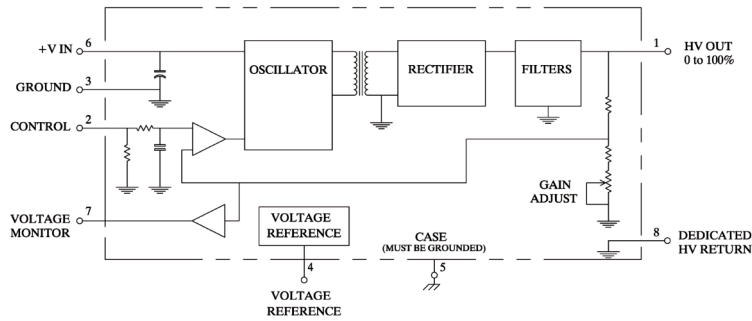

## Mounting Kit

### CM1: MHV Connector

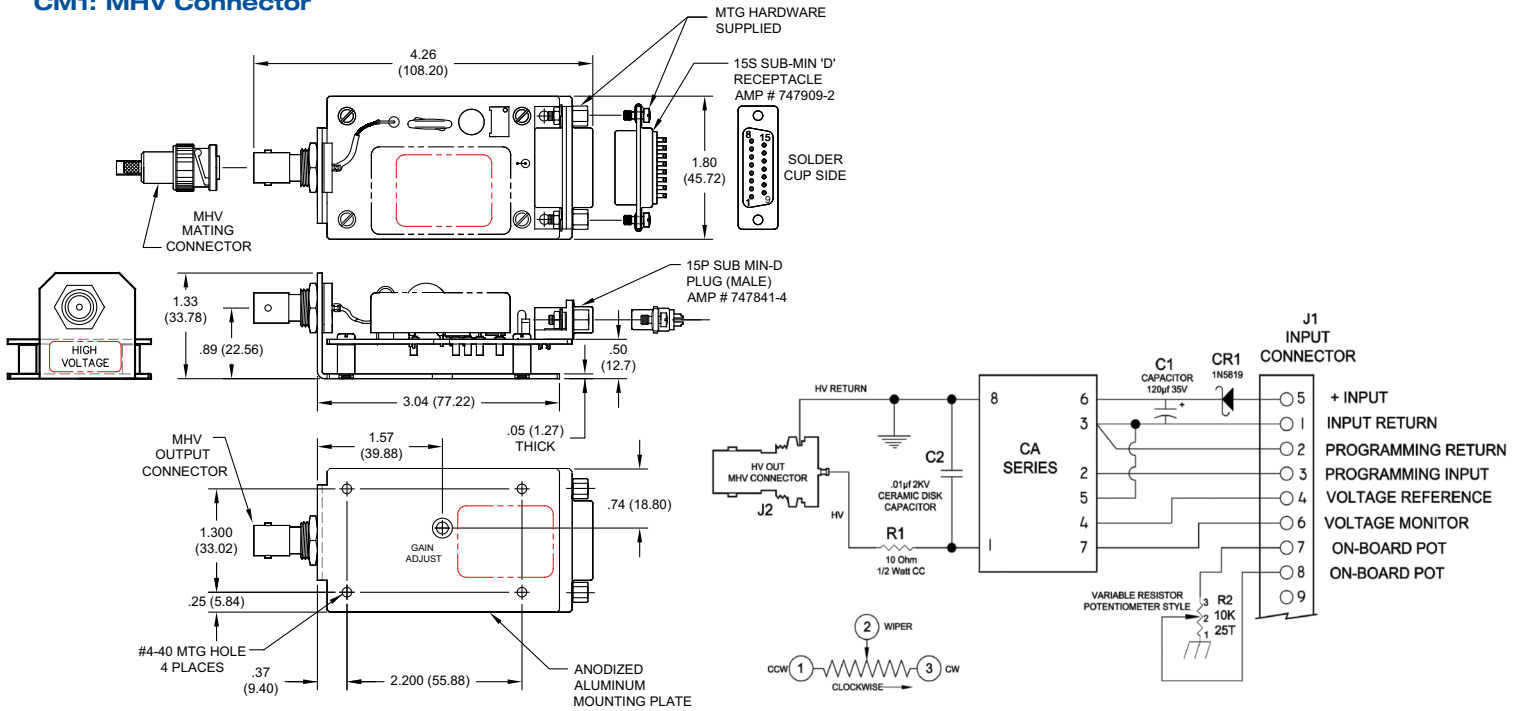

## Product Description

These adapters provide convenient prototyping and evaluation during system development and integration. They allow C Series modules to be mounted to a chassis instead of designed into a PC board. Extra filtering on the input and output improves performance. A schottky diode on the input provides reverse polarity protection. Input connector is via a 15P SUB MIN-D plug (mate supplied) and output is via an SHV style coaxial connector (mate supplied). Please note when ordering a CM3 the C Series is not included and must be ordered separately.

## Programming Instructions

Onboard Potentiometer: connect pins 7 to 4 and 8 to 3, turn potentiometer to adjust high voltage. Or Remote Potentiometer: connect wiper to pin 3, other sides to pins 4 and 2. Or Remote Analog Signal: apply programming voltage to pin 3, return to pin 2.

## Mounting Kit

### CM2: SHV Connector

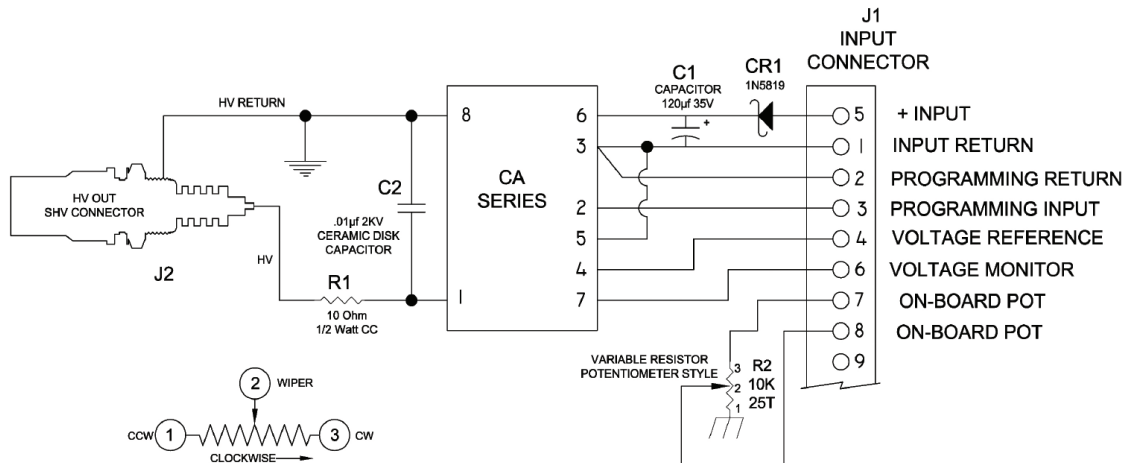
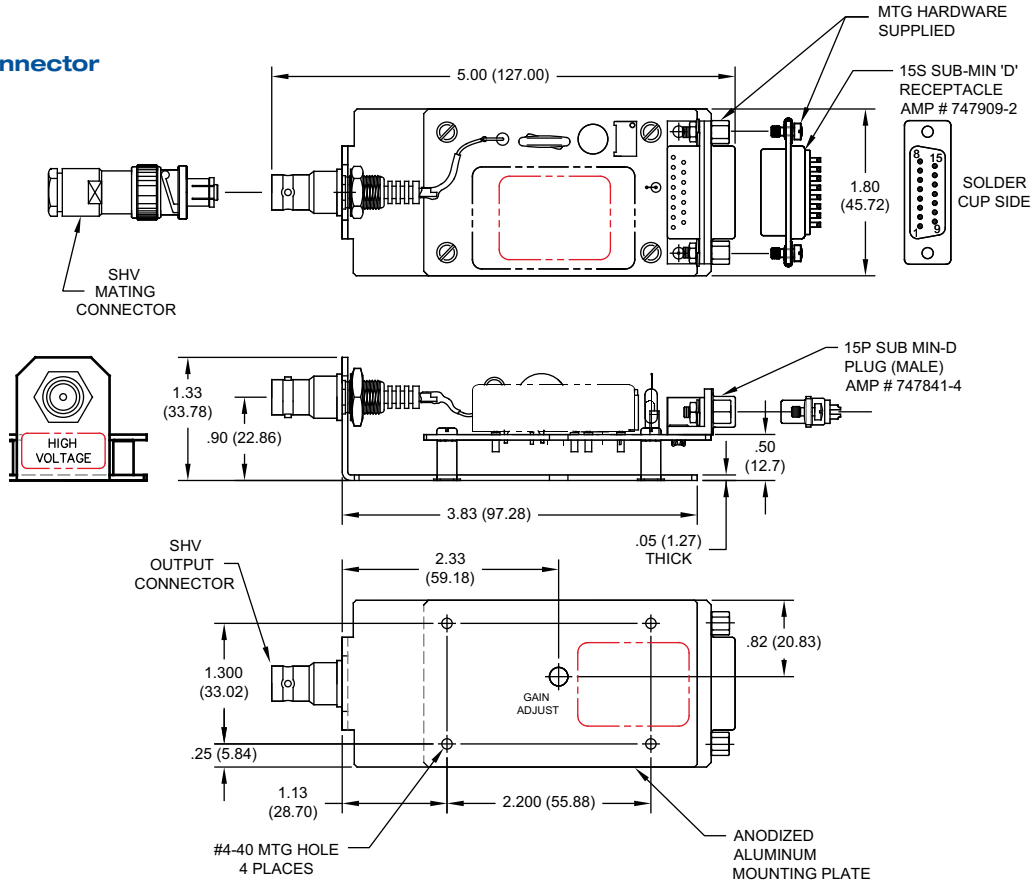

## Product Description

These adapters provide convenient prototyping and evaluation during system development and integration. They allow C Series modules to be mounted to a chassis instead of designed into a PC board. Extra filtering on the input and output improves performance. A schottky diode on the input provides reverse polarity protection. Input connector is via a 15P SUB MIN-D plug (mate supplied) and output is via a SHV style coaxial connector (mate supplied). Please note when ordering a CM3 the C Series is not included and must be ordered separately.

## Programming Instructions

Onboard Potentiometer: connect pins 7 to 4 and 8 to 3, turn potentiometer to adjust high voltage. Or Remote Potentiometer: connect wiper arm to pin 3, other sides to pins 4 and 2. Or Remote Analog Signal: apply programming input to pin 3, return to pin 2.

### Application Notes

#### Connection Diagram for VREF programming

For best performance a separate voltage source should be used for the voltage programming input. If this is not available, the user can utilize the voltage reference output (VREF), along with a user provided potentiometer, for the voltage programming input (VPGM).

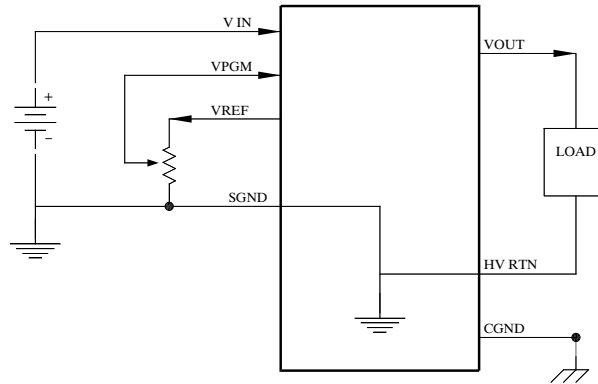

#### Programming Voltage vs Output Voltage

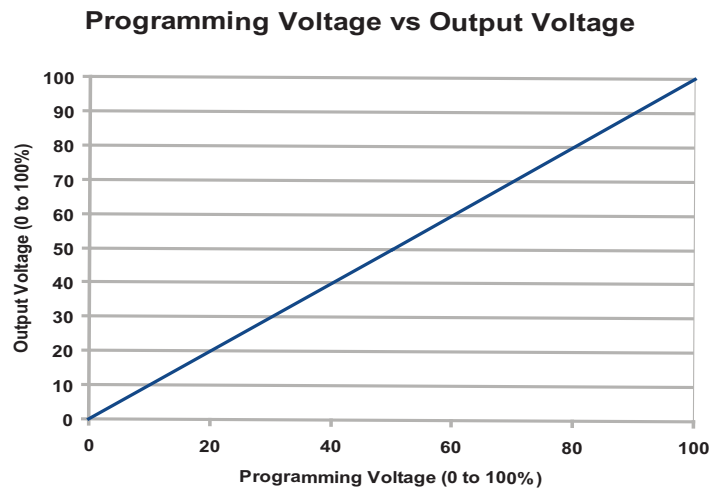

#### Sequencing

For the CA Series, it is recommended to wait at least 100msec after input power is applied before sending a voltage programming command.

#### Dynamic Response

In cases where the output voltage rises above the voltage programming command then settles. To mitigate this effect, ramp the voltage programming input at a slower rate until satisfactory results are achieved.

## X-ON Electronics

Largest Supplier of Electrical and Electronic Components

*Click to view similar products for [Power Management IC Development Tools](#) category:*

*Click to view products by [XP Power](#) manufacturer:*

Other Similar products are found below :

[EVAL-ADM1168LQEBZ](#) [EVB-EP5348UI](#) [MIC23451-AAAYFL EV](#) [MIC5281YMME EV](#) [DA9063-EVAL](#) [ADP122-3.3-EVALZ](#) [ADP130-0.8-EVALZ](#) [ADP130-1.2-EVALZ](#) [ADP130-1.5-EVALZ](#) [ADP130-1.8-EVALZ](#) [ADP1714-3.3-EVALZ](#) [ADP1716-2.5-EVALZ](#) [ADP1740-1.5-EVALZ](#) [ADP1752-1.5-EVALZ](#) [ADP1828LC-EVALZ](#) [ADP1870-0.3-EVALZ](#) [ADP1871-0.6-EVALZ](#) [ADP1873-0.6-EVALZ](#) [ADP1874-0.3-EVALZ](#) [ADP1882-1.0-EVALZ](#) [ADP199CB-EVALZ](#) [ADP2102-1.25-EVALZ](#) [ADP2102-1.875EVALZ](#) [ADP2102-1.8-EVALZ](#) [ADP2102-2-EVALZ](#) [ADP2102-3-EVALZ](#) [ADP2102-4-EVALZ](#) [ADP2106-1.8-EVALZ](#) [ADP2147CB-110EVALZ](#) [AS3606-DB](#) [BQ24010EVM](#) [BQ24075TEVM](#) [BQ24155EVM](#) [BQ24157EVM-697](#) [BQ24160EVM-742](#) [BQ24296MEVM-655](#) [BQ25010EVM](#) [BQ3055EVM](#) [NCV891330PD50GEVB](#) [ISLUSBI2CKIT1Z](#) [LM2744EVAL](#) [LM2854EVAL](#) [LM3658SD-AEV/NOPB](#) [LM3658SDEV/NOPB](#) [LM3691TL-1.8EV/NOPB](#) [LM4510SDEV/NOPB](#) [LM5033SD-EVAL](#) [LP38512TS-1.8EV](#) [EVAL-ADM1186-1MBZ](#) [EVAL-ADM1186-2MBZ](#)