

1 Watt

- +12VDC Input [11.5 to 16V]
- Voltage Regulated
- Output Voltages from 100V to 8000V
- 0 to 100% Programmable Output
- High Reliability 2.6Mhrs MTBF
- <50ppm/°C Temperature Coefficient
- Shielded Case for Low EMI
- Low Ripple - down to 0.002%
- 3 Year Warranty



The C Series is a line of miniature, regulated high voltage power supplies. Each model is programmed from 0 to 100% of rated output via a 0 to +5 volt, DAC-compatible, high-impedance programming input voltage. An externally accessible potentiometer provides adjustable gain trim, allowing for individual calibration of units.

These converters exhibit very low ripple, noise, and EMI/RFI by utilizing a quasi-sinewave oscillator, shielded transformer, excellent filtering techniques and an isolated steel enclosure featuring a separate grounding pin. A proprietary encapsulation process and a custom UL 94 V-0 listed, high-performance formula are used to achieve excellent high voltage and thermal properties. Temperature drift is typically less than 50ppm/°C.

Dimensions:

- C01 - C20:** 1.40 x 1.11 x 0.50" (35.6 x 28.2 x 12.7mm)
- C25 - C40:** 1.75 x 1.11 x 0.50" (44.4 x 28.2 x 12.7mm)
- C50 - C60:** 2.10 x 1.11 x 0.50" (53.3 x 28.2 x 12.7mm)
- C80:** 2.50 x 1.25 x 0.60" (63.50 x 31.75 x 15.24mm)

Key Applications:

- Photo Multiplier Tube
- Solid State Detectors
- Electrophoresis
- Piezo Devices
- Capacitor Charging
- EO Lenses

Input

| Characteristic | Minimum | Typical | Maximum | Units | Notes & Conditions |
|--------------------------|---------|---------|---------|-------|---|
| Input Voltage Range | 11.5 | 13.75 | 16 | VDC | Works with nominal 12V or 15V supply |
| Input Current, Full Load | | | 250 | mA | |
| Input Current, No Load | | | 100 | mA | |
| Programming Inputs | 0 | | 5 | VDC | Analog DC Voltage Controls Output 0 to 100% |
| Input Capacitance | | 440 | | µA | Low ESR |

Output

| Characteristic | Minimum | Typical | Maximum | Units | Notes & Conditions |
|---|--------------------------|---------|---------|--------|---|
| Output Voltage | | | 8000 | VDC | See Models and Ratings Table |
| Output Current | | | 10 | mA | See Models and Ratings Table |
| Output Programming | 0 | | 100 | % | Output Voltage programmable via Analog DC Programming Voltage Input |
| Setpoint Accuracy ⁽⁴⁾ | | ±1 | | % | @ Max Vpgm, No Load |
| Gain Adjust ⁽⁵⁾ | | ±5 | | % | Potentiometer, See Signals & Controls |
| Linearity: Output vs Program ⁽⁶⁾ | | | ±1 | % | 15 to 100% Output |
| Minimum Load | No minimum load required | | | | |
| Start Up Response | | | 250 | msec | At Max Vout, Full Load |
| Line Regulation | 0.05 | | 1.0 | % | 100% Vpgm, Full Load, [Min to Max Input] |
| Load Regulation | 0.07 | | 0.75 | % | 100% Vpgm, 13.75Vin, [NL to FL] |
| Ripple and Noise | 0.002 | | 0.75 | % | 1MHz bandwidth, See Models and Ratings Table |
| Temperature Coefficient | | 50 | | ppm/°C | |
| Stability | | | 100 | ppm/hr | After 30 minute warm up |

Notes

1. Maximum current is available at maximum output voltage.
2. Specifications after 1 hour warm-up, full load, 25°C, unless otherwise noted.
3. Proper thermal management techniques are required to maintain safe case temperature.
4. SET POINT ACCURACY refers to the ability of the unit to accurately deliver the programmed voltage.
5. GAIN ADJUST refers to the ability to alter the gain of the circuit to allow for set-point accuracy error.
6. LINEARITY refers to how much the transfer function can deviate from a straight line in the absence of any set-point error.

Environmental

| Characteristic | Minimum | Typical | Maximum | Units | Notes & Conditions |
|-----------------------|---------|---------|---------|----------|--------------------|
| Operating Temperature | -10 | | +60 | °C | Case Temperature |
| Storage Temperature | -20 | | +90 | °C | |
| Humidity | | | 95 | %RH | Non-condensing |
| Cooling | | | | | Natural convection |
| Thermal Shock Limit | | | 1 | °C/10sec | Natural convection |

Safety Approvals

| Safety Agency | Safety Standard | Notes & Conditions |
|---------------|-------------------------------------|--------------------|
| UL | IEC/UL/CSA/EN 62368 | |
| CE | CE Directive, RoHS and LVD | Where applicable |
| RoHS | RoHS 2 and 3 Directive (2011/65/EU) | Where applicable |

General

| Characteristic | Minimum | Typical | Maximum | Units | Notes & Conditions |
|----------------------------|--|---------|---------|-------|---------------------|
| Isolation: Input to Output | N/A – Input ground is connected to output ground | | | | |
| Construction | Case material is zinc plated steel. Solid vacuum encapsulation, UL 94 V-0 rated. | | | | |
| Switching Frequency | 50 | | 350 | kHz | |
| Mean Time Between Failure | 2.6 | | | MHrs | Per Bellcore TR 332 |

Application Notes

Improved Performance and Protection

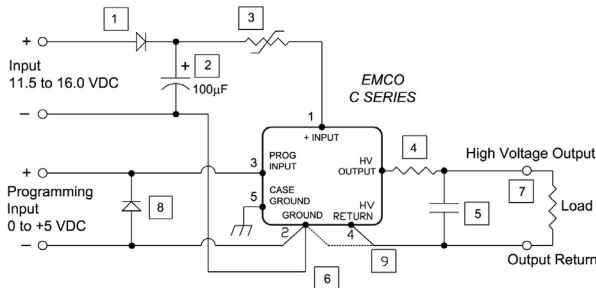

- 1 Diode provides reverse polarity protection.
- 2 Capacitor reduces ripple.
- 3 Resettable fuse (Raychem P/N RXE020,025 or 030) provides indefinite short circuit protection. *Selection depends on model used, load characteristics and operating temperature range.*
- 4 Series resistance increases arc protection and reduces ripple (when used with an output capacitor).
- 5 Capacitor reduces ripple.
- 6 IMPORTANT: Keep Input, Programming and Output return paths separate to eliminate ground loop accuracy errors.
- 7 Conformal coating recommended on all exposed high voltage conductors.
- 8 Diode provides protection against negative programming voltage or negative transient spike.
- 9 Output circuit return to HV return (pin 4) on C50 - C80. On C01-C40, output circuit return to ground (pin 2).

FUNCTIONAL BLOCK DIAGRAM

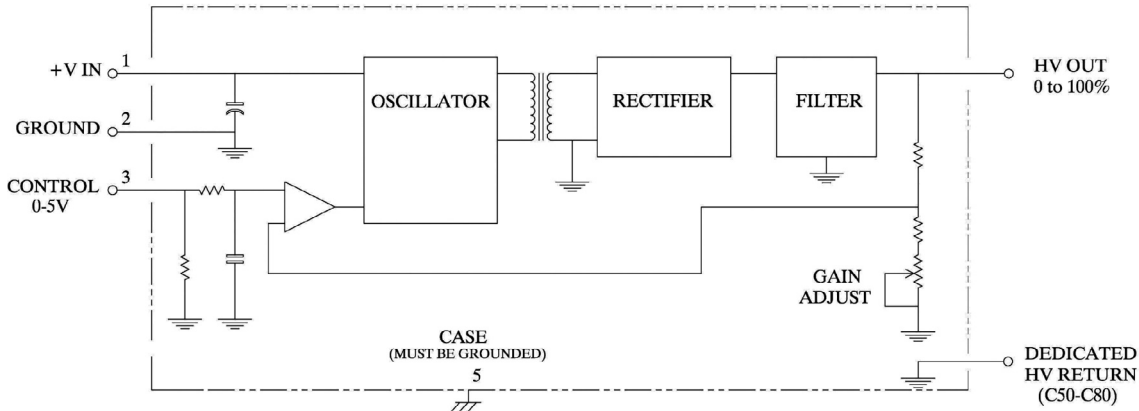

Models & Ratings

| Output Voltage | Output Current ⁽¹⁾ | Regulation | | Ripple | Frequency | Model Number |
|----------------|-------------------------------|------------|---------|---------|------------|--------------|
| | | Load | Line | | | |
| 0 to +100V | 10mA | <0.1% | <0.1% | <0.75% | 200-250kHz | C01 |
| 0 to +200V | 5mA | <0.1% | <0.1% | <0.05% | 250-350kHz | C02 |
| 0 to -200V | 5mA | <0.1% | <1.0% | <0.05% | 75-150kHz | C02N |
| 0 to +300V | 3.3mA | <0.1% | <0.1% | <0.03% | 200-300kHz | C03 |
| 0 to +500V | 2mA | <0.07% | <0.1% | <0.004% | 250-350kHz | C05 |
| 0 to -500V | 2mA | <0.5% | <0.5% | <0.005% | 200-350kHz | C05N |
| 0 to +600V | 1.67mA | <0.1% | <0.1% | <0.003% | 250-300kHz | C06 |
| 0 to -600V | 1.67mA | <0.75% | <0.75% | <0.003% | 125-300kHz | C06N |
| 0 to +1000V | 1mA | <0.3% | <0.3% | <0.005% | 200-250kHz | C10 |
| 0 to -1000V | 1mA | <0.5% | <0.3% | <0.002% | 100-125kHz | C10N |
| 0 to +1250V | 1mA | <0.1% | <0.1% | <0.004% | 200-250kHz | C12 |
| 0 to -1250V | 1mA | <0.175% | <0.1% | <0.003% | 100-125kHz | C12N |
| 0 to +1500V | 0.67mA | <0.1% | <0.1% | <0.002% | 100-125kHz | C15 |
| 0 to -1500V | 0.67mA | <0.2% | <0.2% | <0.002% | 75-100kHz | C15N |
| 0 to +2000V | 0.5mA | <0.15% | <0.1% | <0.002% | 75-100kHz | C20 |
| 0 to -2000V | 0.5mA | <0.15% | <0.1% | <0.002% | 75-100kHz | C20N |
| 0 to +2500V | 0.4mA | <0.03% | <0.2% | <0.1% | 125-150kHz | C25 |
| 0 to -2500V | 0.4mA | <0.5% | <0.2% | <0.2% | 125-150kHz | C25N |
| 0 to +3000V | 0.33mA | <0.03% | <0.05% | <0.1% | 75-100kHz | C30 |
| 0 to -3000V | 0.33mA | <0.03% | <0.075% | <0.2% | 75-100kHz | C30N |
| 0 to +4000V | 0.25mA | <0.25% | <0.2% | <0.1% | 50-125kHz | C40 |
| 0 to -4000V | 0.25mA | <0.2% | <0.1% | <0.1% | 75-150kHz | C40N |
| 0 to +5000V | 0.2mA | <0.35% | <0.1% | <0.1% | 75-150kHz | C50 |
| 0 to -5000V | 0.2mA | <0.25% | <0.1% | <0.1% | 125-175kHz | C50N |
| 0 to +6000V | 0.167mA | <0.25% | <0.1% | <0.1% | 125-175kHz | C60 |
| 0 to -6000V | 0.167mA | <0.25% | <0.15% | <0.1% | 125-175kHz | C60N |
| 0 to +8000V | 0.125mA | <0.75% | <0.15% | <0.2% | 100-150kHz | C80 |
| 0 to -8000V | 0.125mA | <0.75% | <0.25% | <0.2% | 100-150kHz | C80N |

Mechanical Details

C01-C20

Top View

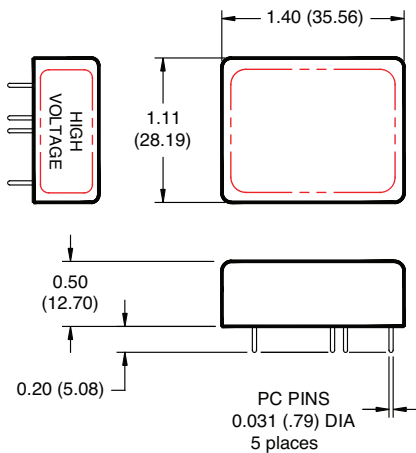

Bottom View

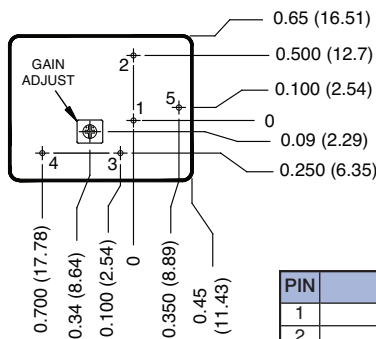

| PIN | FUNCTION |
|-----|---------------------|
| 1 | (+) Input |
| 2 | Ground |
| 3 | Programming Voltage |
| 4 | HV Out |
| 5 | Case Ground |

PCB Layout

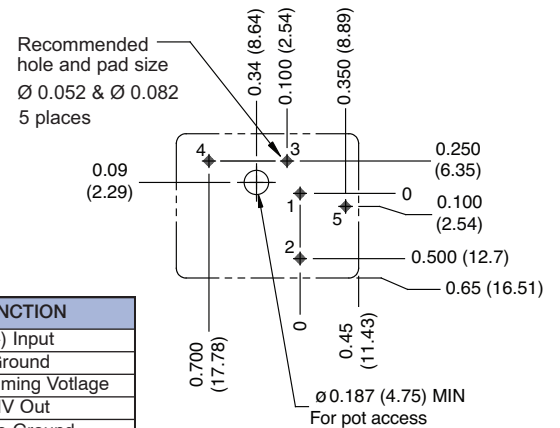

All dimensions are in inches (mm)
 Tolerance: X.XX ±0.02 (0.51)
 Pin Tolerance: ±0.005 (0.127)
 Weight: C01-C20: 1.1oz (31g)

All grounds internally connected except case. Case ground (Pin5) must be connected to ground, with no more than 50V between case ground (Pin 5) and circuit ground (Pin 2).

Mechanical Details

C25-C40

Top View

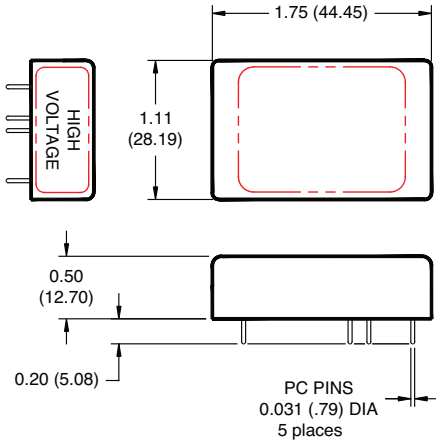

Bottom View

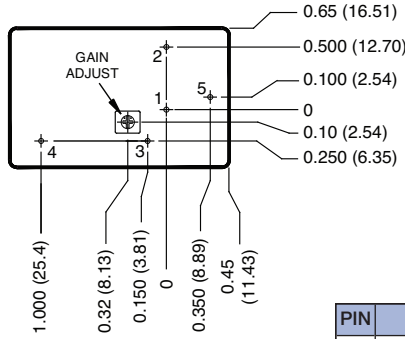

PCB Layout

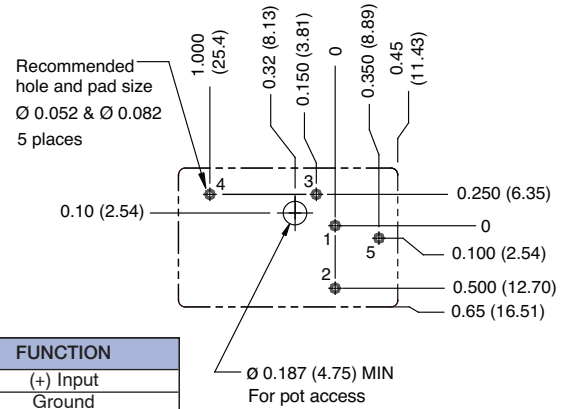

| PIN | FUNCTION |
|-----|---------------------|
| 1 | (+) Input |
| 2 | Ground |
| 3 | Programming Votlage |
| 4 | HV Out |
| 5 | Case Ground |

C50-C60

Top View

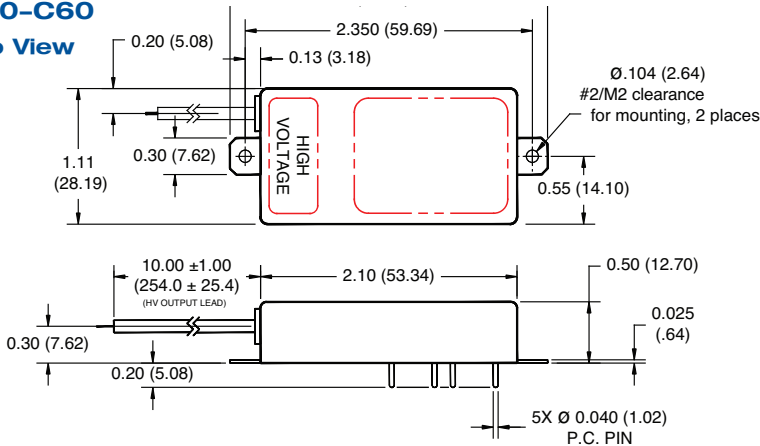

PCB Layout

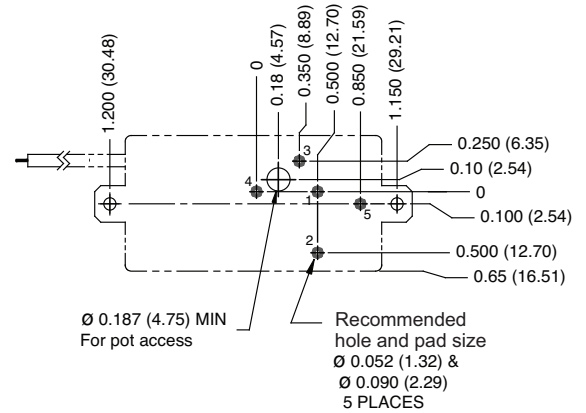

Bottom View

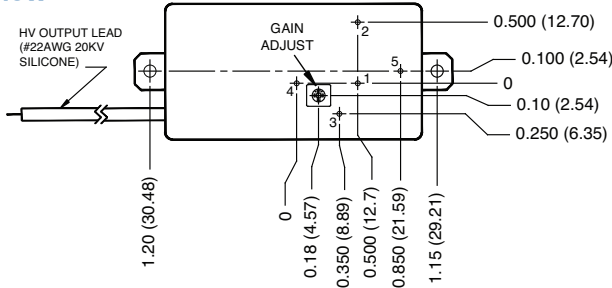

| PIN | FUNCTION |
|------|---------------------|
| 1 | (+) Input |
| 2 | Ground |
| 3 | Programming Votlage |
| 4 | HV Return |
| 5 | Case Ground |
| LEAD | HV Out |

All dimensions are in inches (mm)
 Tolerance: X.XX ±0.02 (0.51)
 Pin Tolerance: ±0.005 (0.127)
 Weight: C25-C40: 1.3oz (36.8g)
 C50-C60: 1.8oz (51g)

All grounds internally connected except case. Case ground (Pin5) must be connected to ground, with no more than 50V between case ground (Pin 5) and circuit ground (Pin 2).

Mechanical Details

C80

Top View

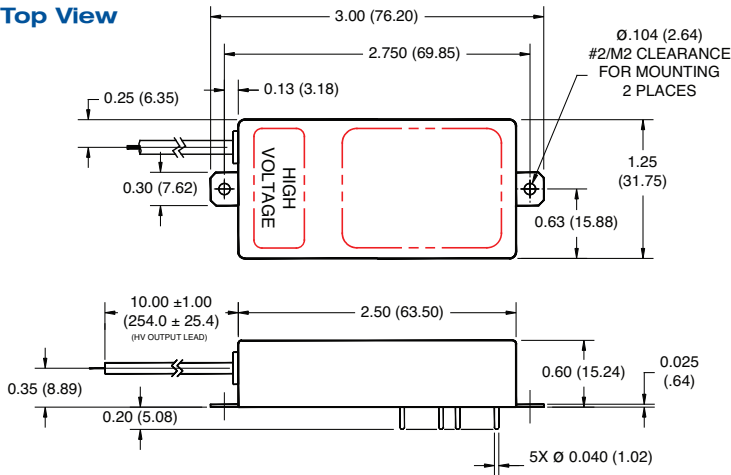

PCB Layout

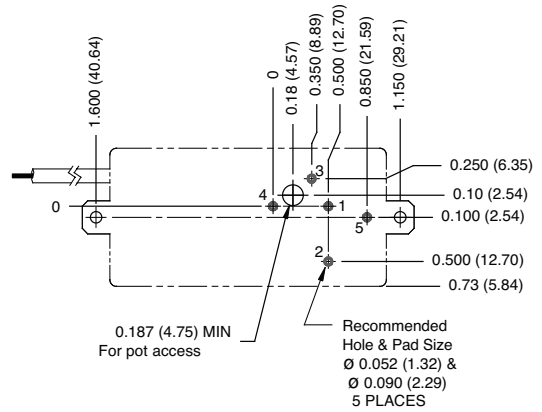

Bottom View

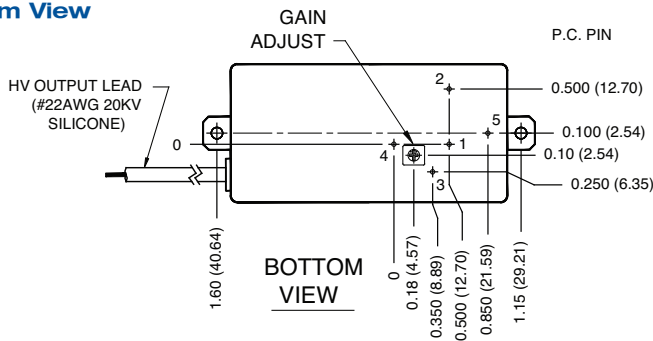

| PIN | FUNCTION |
|------|---------------------|
| 1 | (+) Input |
| 2 | Ground |
| 3 | Programming Voltage |
| 4 | HV Return |
| 5 | Case Ground |
| LEAD | HV Out |

All dimensions are in inches (mm)
 Tolerance: X.XX ± 0.02 (0.51)
 Pin Tolerance: ± 0.005 (0.127)
 Weight: C80: 2.0oz (57g)

All grounds internally connected except case. Case ground (Pin5) must be connected to ground, with no more than 50V between case ground (Pin 5) and circuit ground (Pin 2).

Mounting Kit

CM3 fits models C25-C40

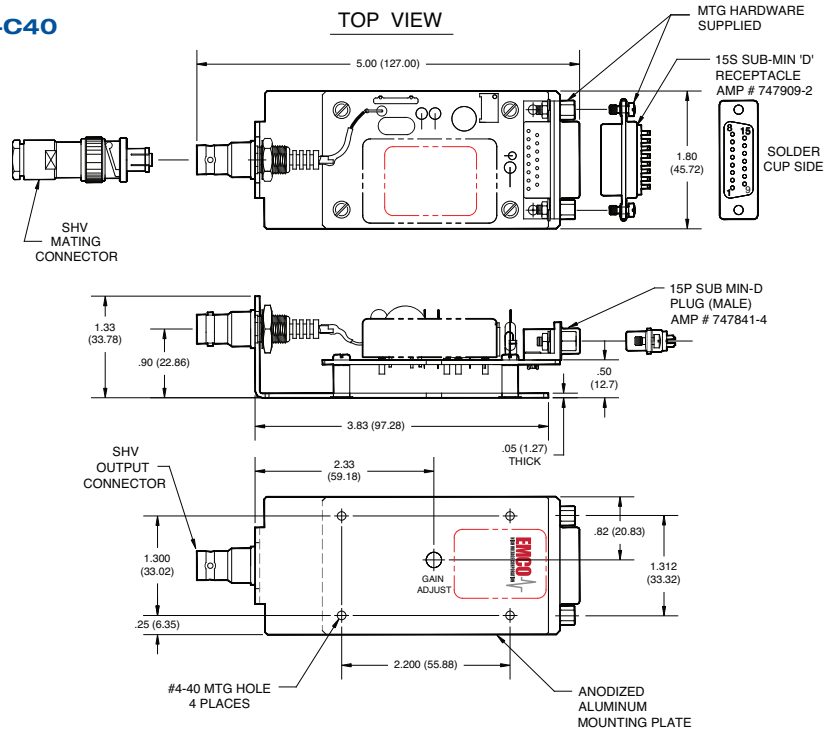

Block Diagram

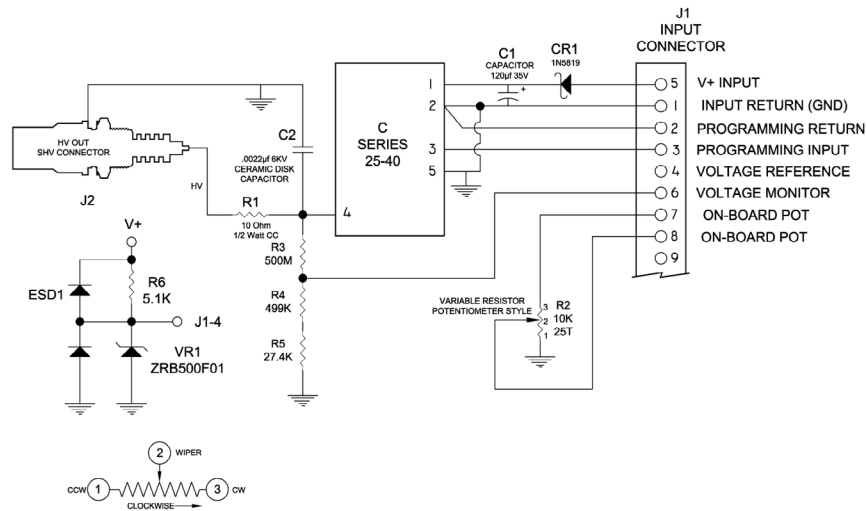

Notes

Dimensions are in inches (metric equivalents are in parentheses)

Dimensional tolerances: .xx +/- 0.02 (0.51mm)
.xxx +/- 0.005 (0.127mm)

Product Description

These adapters provide convenient prototyping and evaluation during system development and integration. They allow C Series modules to be mounted to a chassis instead of designed into a PC board. Extra filtering on the input and output improves performance. A schottky diode on the input provides reverse polarity protection. Input connector is via a 15P SUB MIN-D plug (mate supplied) and output is via an SHV style coaxial connector (mate supplied). Please note when ordering a CM3 the C Series is not included and must be ordered separately.

Programming Instructions

- Onboard Potentiometer: connect pins 7 to 4 and 8 to 3, turn potentiometer to adjust high voltage.
- Or Remote Potentiometer: connect wiper arm to pin 3, other sides to pins 4 and 2.
- Or Remote Analog Signal: apply programming voltage to pin 3, return to pin 2.

Mounting Kit

CM4 fits models C50-C80

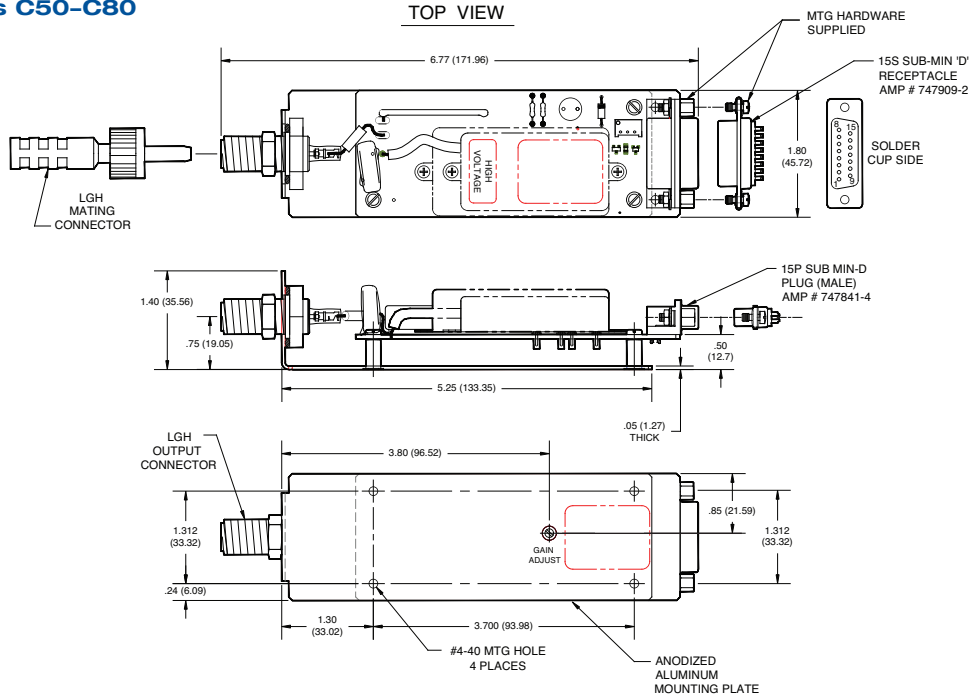

Block Diagram

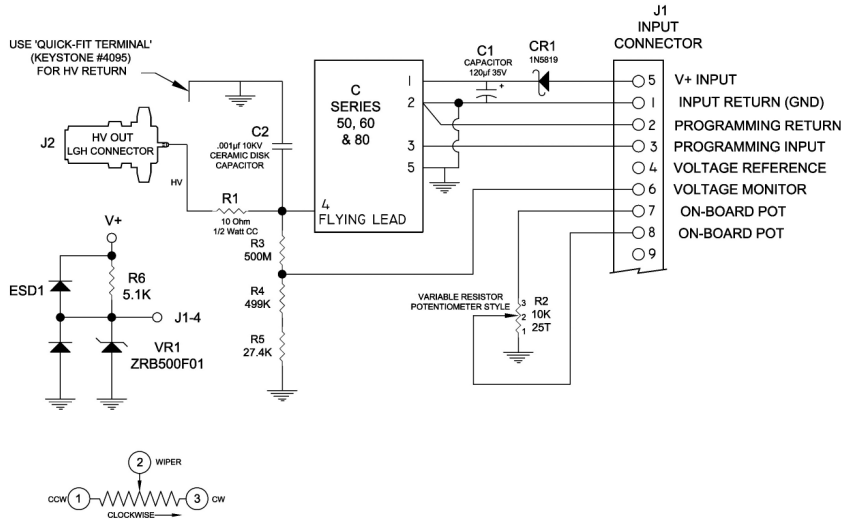

Notes

Dimensions are in inches (metric equivalents are in parentheses)

Dimensional tolerances: .xx +/- 0.02 (0.51mm)
.xxx +/- 0.005 (0.127mm)

Product Description

These adapters provide convenient prototyping and evaluation during system development and integration. They allow C Series modules to be mounted to a chassis instead of designed into a PC board. Extra filtering on the input and output improves performance. A schottky diode on the input provides reverse polarity protection. Input connector is via a 15P SUB MIN-D plug (mate supplied) and output is via an SHV style coaxial connector (mate supplied). Please note when ordering a CM3 the C Series is not included and must be ordered separately.

Programming Instructions

Onboard Potentiometer: connect pins 7 to 4 and 8 to 3, turn potentiometer to adjust high voltage.
Or Remote Potentiometer: connect wiper arm to pin 3, other sides to pins 4 and 2.
Or Remote Analog Signal: apply programming voltage to pin 3, return to pin 2.

X-ON Electronics

Largest Supplier of Electrical and Electronic Components

Click to view similar products for [Power Management IC Development Tools](#) category:

Click to view products by [XP Power](#) manufacturer:

Other Similar products are found below :

[EVAL-ADM1168LQEBZ](#) [EVB-EP5348UI](#) [MIC23451-AAAYFL EV](#) [MIC5281YMME EV](#) [DA9063-EVAL](#) [ADP122-3.3-EVALZ](#) [ADP130-0.8-EVALZ](#) [ADP130-1.2-EVALZ](#) [ADP130-1.5-EVALZ](#) [ADP130-1.8-EVALZ](#) [ADP1714-3.3-EVALZ](#) [ADP1716-2.5-EVALZ](#) [ADP1740-1.5-EVALZ](#) [ADP1752-1.5-EVALZ](#) [ADP1828LC-EVALZ](#) [ADP1870-0.3-EVALZ](#) [ADP1871-0.6-EVALZ](#) [ADP1873-0.6-EVALZ](#) [ADP1874-0.3-EVALZ](#) [ADP1882-1.0-EVALZ](#) [ADP199CB-EVALZ](#) [ADP2102-1.25-EVALZ](#) [ADP2102-1.875EVALZ](#) [ADP2102-1.8-EVALZ](#) [ADP2102-2-EVALZ](#) [ADP2102-3-EVALZ](#) [ADP2102-4-EVALZ](#) [ADP2106-1.8-EVALZ](#) [ADP2147CB-110EVALZ](#) [AS3606-DB](#) [BQ24010EVM](#) [BQ24075TEVM](#) [BQ24155EVM](#) [BQ24157EVM-697](#) [BQ24160EVM-742](#) [BQ24296MEVM-655](#) [BQ25010EVM](#) [BQ3055EVM](#) [NCV891330PD50GEVB](#) [ISLUSBI2CKIT1Z](#) [LM2744EVAL](#) [LM2854EVAL](#) [LM3658SD-AEV/NOPB](#) [LM3658SDEV/NOPB](#) [LM3691TL-1.8EV/NOPB](#) [LM4510SDEV/NOPB](#) [LM5033SD-EVAL](#) [LP38512TS-1.8EV](#) [EVAL-ADM1186-1MBZ](#) [EVAL-ADM1186-2MBZ](#)