

DNR Series



- Up to 90% Efficiency
- Wide Adjustment Range
- Parallel Function
- DC Standby Versions
- Full Power from $-40\text{ }^{\circ}\text{C}$ to $+60\text{ }^{\circ}\text{C}$
- Connector Options
- 3 Year Warranty

Specification

Input

Input Voltage	<ul style="list-style-type: none"> • 90-132/180-264 VAC, auto select, 210-375 VDC (DNR120AS, DNR240PS) • 90-264 VAC, 120-375 VDC (DNR480PS)
Input Frequency	<ul style="list-style-type: none"> • 47-63 Hz
Input Current	<ul style="list-style-type: none"> • See tables
Inrush Current	<ul style="list-style-type: none"> • 24/48 A at 115/230 VAC (DNR120) • 30/60 A at 115/230 VAC (DNR240) • 25/50 A at 115/230 VAC (DNR480)
Power Factor	<ul style="list-style-type: none"> • 0.7 typical (DNR120, DNR240) • 0.9 typical (DNR480)
Earth Leakage Current	<ul style="list-style-type: none"> • 0.8 mA max
Input Protection	<ul style="list-style-type: none"> • T3.15A, 250 VAC (DNR120) • T6.3A, 250 VAC (DNR240) • T10A, 250 VAC (DNR480)

Output

Output Voltage	<ul style="list-style-type: none"> • See tables
Output Voltage Trim	<ul style="list-style-type: none"> • See tables
Initial Set Accuracy	<ul style="list-style-type: none"> • $\pm 1\%$
Minimum Load	<ul style="list-style-type: none"> • No minimum load required
Start Up Delay	<ul style="list-style-type: none"> • $< 1\text{ s}$ (may increase at low temperature extremes)
Start Up Rise Time	<ul style="list-style-type: none"> • $< 150\text{ ms}$
Hold Up Time	<ul style="list-style-type: none"> • 25/30 ms at 115/230 VAC
Line Regulation	<ul style="list-style-type: none"> • $\pm 0.5\%$ max
Load Regulation	<ul style="list-style-type: none"> • $\pm 1\%$ ($\pm 5\%$ for units in parallel)
Parallel Operation	<ul style="list-style-type: none"> • A maximum of 3 units can be paralleled (not with standby system). Total power available is 90% of the rated current of each unit. Minimum load per unit 10%. Redundancy module DPM10 available for load currents up to 10 A, contact sales.
Transient Response	<ul style="list-style-type: none"> • 4% max deviation recovering to within 1% in 2 ms for a 50% load change
Ripple & Noise	<ul style="list-style-type: none"> • 50 mV pk-pk (DNR120) • 100 mV pk-pk (DNR240, DNR480) • 20 MHz bandwidth (may increase at low temperature extremes)
Overvoltage Protection	<ul style="list-style-type: none"> • Output clamps at 125-140% Vnom, auto recovery
Overload Protection	<ul style="list-style-type: none"> • 105-145% constant current, auto recovery • 120-165% constant current (DNR240)
Temp. Coefficient	<ul style="list-style-type: none"> • $\pm 0.03\%/^{\circ}\text{C}$

General

Efficiency	<ul style="list-style-type: none"> • See table
Isolation	<ul style="list-style-type: none"> • 3000 VAC Input to Output • 1500 VAC Input to Ground • 500 VAC Output to Ground
Switching Frequency	<ul style="list-style-type: none"> • See table
Signals	<ul style="list-style-type: none"> • DC ON indicator Green LED, • DC LOW indicator Red LED • DC OK: 24 V and standby models
MTBF	<ul style="list-style-type: none"> • 430 kHrs typical Bellcore, Issue 6 at $+40\text{ }^{\circ}\text{C}$, GB
DIN Rail	<ul style="list-style-type: none"> • Compatible with TS35/7.5 or TS35/15

Environmental

Operating Temperature	<ul style="list-style-type: none"> • DNR120: $-35\text{ }^{\circ}\text{C}$ to $+70\text{ }^{\circ}\text{C}$, derate linearly from $+60\text{ }^{\circ}\text{C}$ at $2.5\%/^{\circ}\text{C}$, start up at $-30\text{ }^{\circ}\text{C}$ • DNR240: $-40\text{ }^{\circ}\text{C}$ to $+70\text{ }^{\circ}\text{C}$, derate linearly from $+60\text{ }^{\circ}\text{C}$ at $2.5\%/^{\circ}\text{C}$, start up at $-35\text{ }^{\circ}\text{C}$ • DNR480: $-40\text{ }^{\circ}\text{C}$ to $+70\text{ }^{\circ}\text{C}$, derate linearly from $+55\text{ }^{\circ}\text{C}$ at $2.5\%/^{\circ}\text{C}$, start up at $-35\text{ }^{\circ}\text{C}$ (see derating curves)
Cooling	<ul style="list-style-type: none"> • Convection-cooled with 25mm free space all sides
Operating Humidity	<ul style="list-style-type: none"> • 20-95% RH, non-condensing
Storage Temperature	<ul style="list-style-type: none"> • $-40\text{ }^{\circ}\text{C}$ to $+85\text{ }^{\circ}\text{C}$
Shock	<ul style="list-style-type: none"> • 15 g, 11 ms, 3 axes, 6 faces, 3 shocks per face
Vibration	<ul style="list-style-type: none"> • 2 g, 10 Hz to 500 Hz, along X, Y & Z axis, 60 min/axis, mounted on rail

EMC & Safety

Emissions	<ul style="list-style-type: none"> • EN55022, class B conducted & radiated
Harmonic Currents	<ul style="list-style-type: none"> • EN61000-3-2, class A
Voltage Flicker	<ul style="list-style-type: none"> • EN61000-3-3
ESD Immunity	<ul style="list-style-type: none"> • EN61000-4-2, level 4 Perf Criteria A
Radiated Immunity	<ul style="list-style-type: none"> • EN61000-4-3, level 3 Perf Criteria A
EFT/Burst	<ul style="list-style-type: none"> • EN61000-4-4, level 4 Perf Criteria A
Surge	<ul style="list-style-type: none"> • EN61000-4-5, installation class 3, Perf Criteria A
Conducted Immunity	<ul style="list-style-type: none"> • EN61000-4-6, level 3 Perf Criteria A
Magnetic Field	<ul style="list-style-type: none"> • EN61000-4-8, level 4 Perf Criteria A
Dips & Interruptions	<ul style="list-style-type: none"> • EN61000-4-11, 30% 10 ms, 60% 100 ms, 100% 5000 ms Perf Criteria A, A, B
Safety Approvals	<ul style="list-style-type: none"> • EN60950-1 UL508 UL60950-1, cUL60950-1 Pollution Degree 2, CE Mark, UL60950-1 Overvoltage Category II, UL508 Overvoltage Category III, ANSI/ISA 12.12.01. (Class 1, Division 2, Groups A,B,C and D)

Models and Ratings

Output Voltage	Input Current (typ.)		Output Voltage Trim	Output Current	Efficiency (typ.)	Typical Switching Frequency	Model Number
	115 VAC	230 VAC					
12 V	2.20 A	0.83 A	11.4-14.5 V	10.0 A	84%	80 kHz	DNR120AS12-I ^(1,2)
24 V	2.20 A	0.83 A	22.5-28.5 V	5.0 A	86%	80 kHz	DNR120AS24-I ^(1,2)
48 V	2.20 A	0.83 A	45.0-55.0 V	2.5 A	87%	80 kHz	DNR120AS48-I ^(1,2)
24 V	4.00 A	1.55 A	22.5-28.5 V	10.0 A	89%	40 kHz	DNR240PS24-I ^(1,2)
48 V	4.00 A	1.55 A	47.0-56.0 V	5.0 A	90%	40 kHz	DNR240PS48-I ^(1,2)
24 V	4.90 A	2.50 A	22.5-28.5 V	20.0 A	89%	65 kHz	DNR480PS24-I ^(1,2)
48 V	4.90 A	2.50 A	47.0-56.0 V	10.0 A	90%	65 kHz	DNR480PS48-I ^(1,2)

Notes

1. Add suffix 'D' for detachable connector option.
2. For DC standby, remove '-I' and add '#' to the end of the model number.

Derating Curves

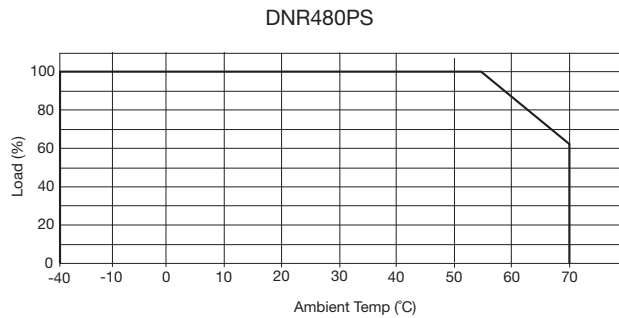
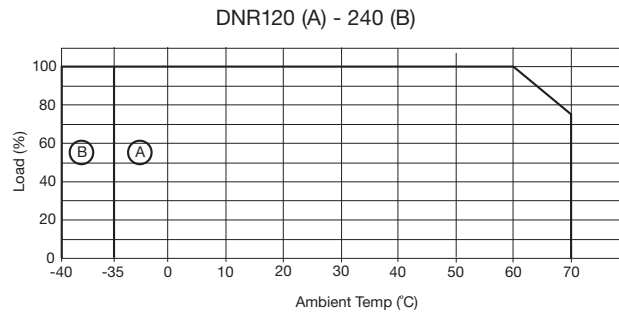

DC OK

Volt free contact closed when voltage at unit output is within specification. In standby system configured as shown this voltage may be provided by the PSU or battery.

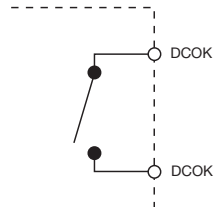

Open = Output fail
Closed = Output good

Contact Rating: 0.3 A at 60 VDC
500 VDC isolation

Mechanical Details

120 W Models

Optional detachable connector ('D' Option)

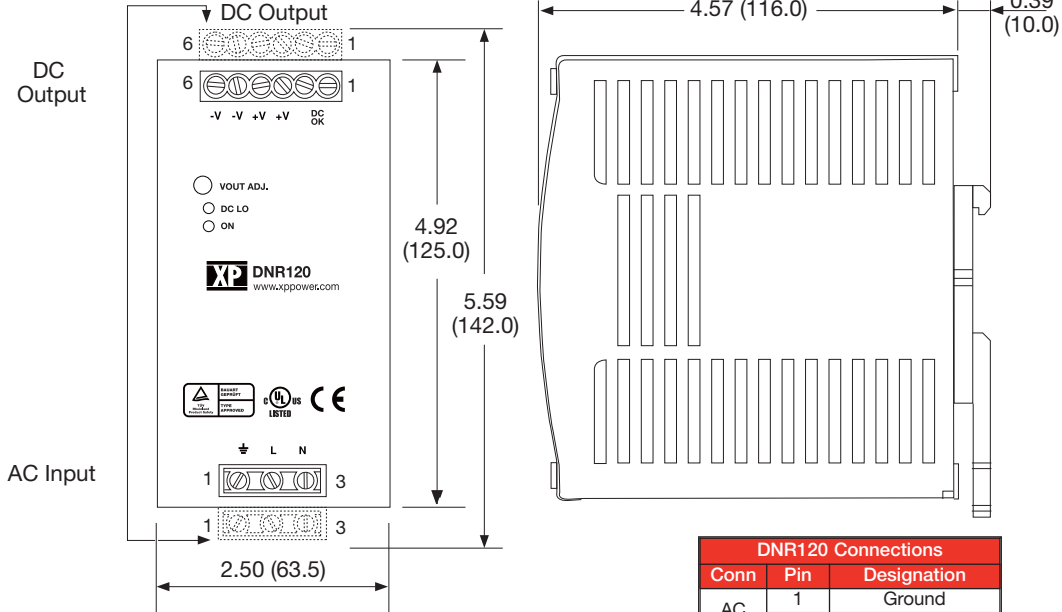

Notes

1. All dimensions in inches (mm).
2. Weight 2.0 lb (920 g) approx.
3. Tolerance: ±0.02 (0.5) maximum.
4. Screw terminal: 10-24 AWG cable size. Detachable connector version: 14-24AWG cable size.
5. Connection screw maximum torque: Input: 9 lbs-in (1.0 Nm), Output: 5.5 lbs-in (0.6 Nm)

DNR120 Connections		
Conn	Pin	Designation
AC Input	1	Ground
	2	Line
	3	Neutral
DC Output	1	DC OK *
	2	DC OK *
	3	Positive
	4	Positive
	5	Negative
	6	Negative

* 24 V & standby models only.

240 W Models

Optional detachable connector ('D' Option)

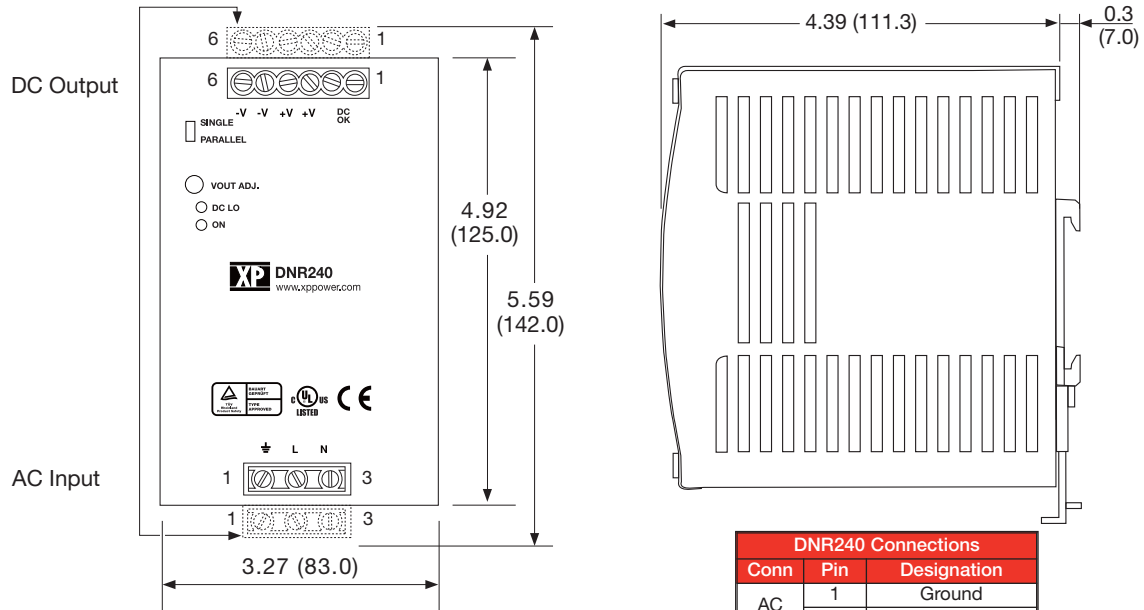

Notes

1. All dimensions in inches (mm).
2. Weight 3.0 lb (1360 g) approx.
3. Tolerance: ±0.02 (0.5) maximum.
4. Screw terminal: 10-24 AWG cable size. Detachable connector version: 14-24AWG cable size.
5. Connection screw maximum torque: Input: 9 lbs-in (1.0 Nm), Output: 5.5 lbs-in (0.6 Nm)

DNR240 Connections		
Conn	Pin	Designation
AC Input	1	Ground
	2	Line
	3	Neutral
DC Output	1	DC OK*
	2	DC OK*
	3	Positive
	4	Positive
	5	Negative
	6	Negative

* 24 V & standby models only.

Mechanical Details

480 W Models

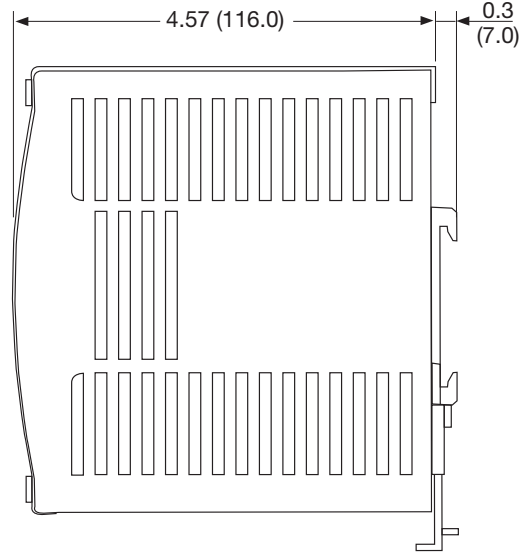
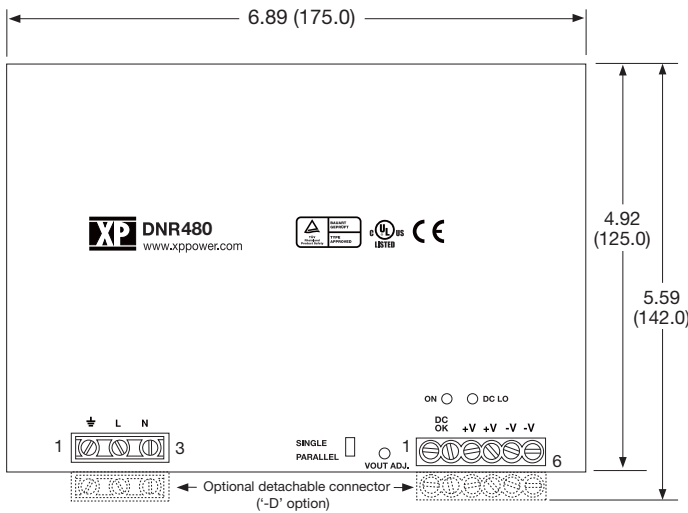

Notes

1. All dimensions in inches (mm).
2. Weight 4.2 lb (1920 g) approx.
3. Tolerance: ±0.02 (0.5) maximum.
4. Screw terminal: 10-24 AWG cable size. Detachable connector version: 14-24 AWG cable size.
5. Connection screw maximum torque: Input: 9 lbs-in (1.0 Nm), Output: 5.5 lbs-in (0.6 Nm)

DNR480PS Connections		
Conn	Pin	Designation
AC Input	1	Ground
	2	Neutral
	3	Line
DC Output	1	DC OK*
	2	DC OK*
	3	Positive
	4	Positive
	5	Negative
	6	Negative

* 24 V and standby models only.

Standby Versions

Maximum current drain from battery by PSU when inactive 22 mA.

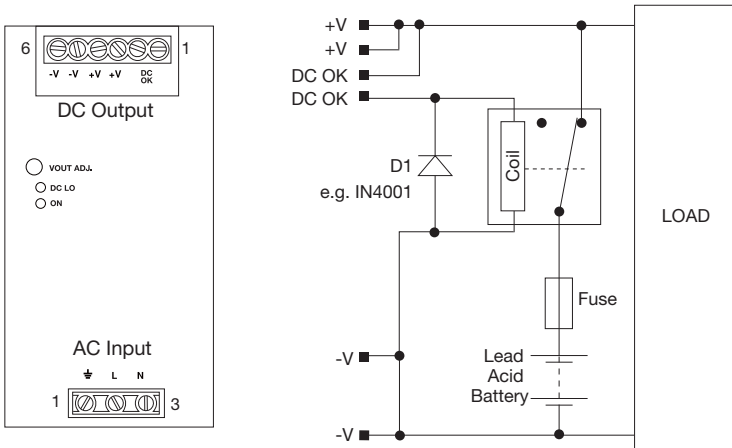

DNR120-480 Connections					
Conn	Pin	Designation	Conn	Pin	Designation
AC Input	1	Ground	DC Output	1	DC OK
	2	Line		2	DC OK
	3	Neutral		3	Positive
			4	Positive	
			5	Negative	
			6	Negative	

Notes

1. Suffix # indicates DC standby version.
2. With AC in, unit provides power to the load and to charge the battery. The DC OK signal acts by sensing a voltage on +V and holds the relay closed.
3. With loss of AC in, battery voltage is present on +V. DC OK signal holds the relay closed. Battery supplies power to the load.
4. As the battery discharges, its voltage falls. When this falls below the level shown in the table the DC OK signal switches off to allow the relay to open to disconnect and protect the battery.

Output Set Voltages For Standby Versions				
Model ⁽¹⁾	Voltage	DC OK Signal Off	Current	DC OK Shutoff
DNR120AS12#	13.6 V	10.30-11.30 V	8.8 A	10.8 V ±5%
DNR120AS24#	27.2 V	21.10-22.10 V	4.4 A	21.6 V ±5%
DNR120AS48#	54.5 V	42.70-43.70 V	2.2 A	43.2 V ±5%
DNR240PS24#	27.2 V	21.10-22.10 V	8.8 A	21.6 V ±5%
DNR240PS48#	54.5 V	42.70-43.70 V	4.4 A	43.2 V ±5%
DNR480PS24#	27.2 V	21.10-22.10 V	17.6 A	21.6 V ±5%
DNR480PS48#	54.5 V	42.70-43.70 V	8.8 A	43.2 V ±5%

X-ON Electronics

Largest Supplier of Electrical and Electronic Components

Click to view similar products for [DIN Rail Power Supplies](#) category:

Click to view products by [XP Power](#) manufacturer:

Other Similar products are found below :

[PS-S6024](#) [DVP01PU-S](#) [DVP06AD-S](#) [DVP06XA-S](#) [DVDPNET-SL](#) [DVPDT01-S](#) [DVPPS01](#) [PS-6012](#) [PS9Z-5R1G](#) [PS-C24024](#)
[DVP08ST11N](#) [DVPACAB530](#) [DVPCOPM-SL](#) [DVPEN01-SL](#) [DVPPF01-S](#) [ADNB008-48-1PM-C](#) [ADNB017-24-1PM-C](#) [ADNB040-24-1PM-C](#) [ADNB034-12-1PM-C](#) [SS14011524](#) [PS-UPS40](#) [PSC-6024](#) [PSD-A60W12](#) [96PS-A120WDIN](#) [PSD-A60W48](#) [PSD-A40W12](#) [PSD-A40W24](#) [SMP21-L20-DC24V-5A](#) [PSD-A40W48](#) [S8T-DCBU-02](#) [PS-S4024](#) [NTPS-24-1.3](#) [ZI-20](#) [PST-96024](#) [S82YVSC4P](#) [PS-S4005](#) [PS-10024](#) [PS-S10024](#) [PS-C12024](#) [PSP-480S24](#) [PS-C48024](#) [PSC-2024](#) [PSC-4012](#) [PSC-4048](#) [PSC-9615](#) [PSC-15124](#) [PSC-15148](#) [PSC-24148](#) [PSC-48148](#) [TRIO-PS-2G/1AC/12DC/5/C2LP](#)