

40 Watts

- 40 W Convection Rating
- 2" by 3" Footprint
- Low 1.04" Profile
- High Efficiency
- Medical, ITE and Household Appliance Approvals
- Class I & Class II Installations
- High Power Density
- Less than 0.3 W No Load Input Power
- 3 Year Warranty



The FCS40 series is designed to minimize the no load power consumption and maximize efficiency to facilitate equipment design to meet the latest environmental legislation. Approved for medical and ITE applications in either Class I or Class II installations, this range of single output AC-DC power supplies are packaged in a low profile 1.04" height with a foot print of just 2" by 3". The FCS40 provides up to 40W convection-cooled over the full 90-264 VAC input range, and operates down to 80 VAC with minimal de-rating. The power supply features two AC line fuses and low leakage currents required by medical applications. The low profile, low noise and safety approvals covering ITE and medical standards allows the versatile FCS40 series to be used in a wide range of applications.

Dimensions:

FCS40:

2.00 x 3.00 x 1.04" (50.8 x 76.2 x 26.4 mm)

Models & Ratings

Output Power	Output Voltage	Output Current	Efficiency ⁽¹⁾	Model Number
40 W	12.0 V	3.34 A	82%	FCS40US12
40 W	15.0 V	2.67 A	85%	FCS40US15
40 W	18.0 V	2.23 A	85%	FCS40US18
40 W	24.0 V	1.67 A	85%	FCS40US24
40 W	36.0 V	1.11 A	84%	FCS40US36
40 W	48.0 V	0.83 A	86%	FCS40US48

Notes

1. Typical efficiency measured at full load and 230 VAC input.

Mechanical Details

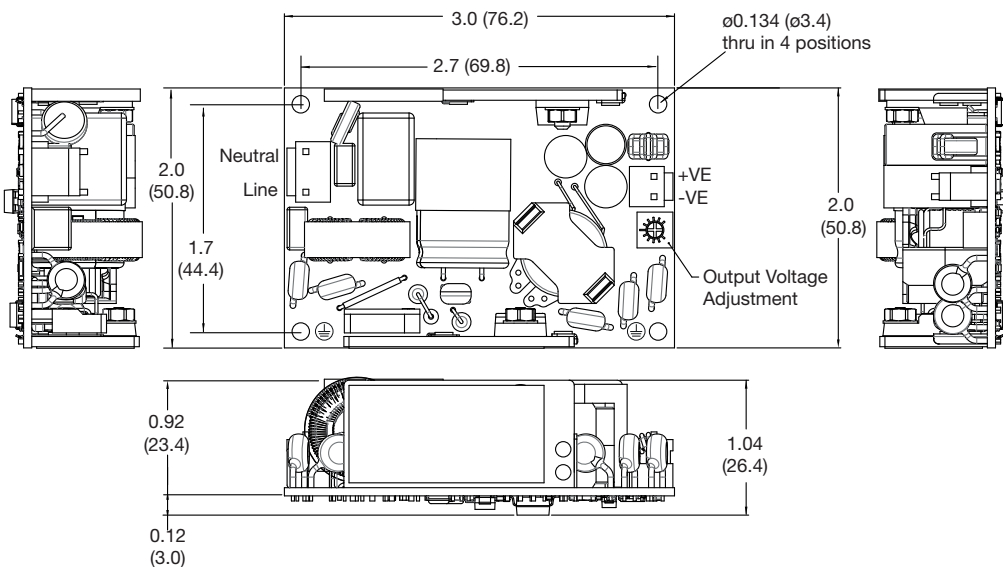

CN1 - Input Connector

Pin 1	Line
Pin 2	Not Fitted
Pin 3	Neutral

Mates with JST housing VHR-3N and JST Series SVH-21T-P1.1 crimp terminals

CN2 - Output Connector

Pin 1	+Vout
Pin 2	-Vout

Mates with JST housing VHR-2N and JST Series SVH-21T-P1.1 crimp terminals

Notes

1. All dimensions shown in inches (mm). Tolerance: ± 0.02 (0.5)
2. Weight: 0.19 lbs (86 g) approx.

Mounting hole marked with \oplus must be connected to safety earth for class I applications

Summary

Characteristic	Minimum	Typical	Maximum	Units	Notes & Conditions
Input Range	80	115/230	264	VAC	Derate output from 100% at 90 VAC to 90% at 85 VAC and 80% at 80 VAC
No Load Input Power			0.3	W	
Efficiency		86		%	230 VAC (see models and ratings table)
Operating Temperature	-25		+70	°C	See derating curve (fig.1)
Safety Approvals	ITE	IEC60950-1, IEC62368-1, EN62368-1, cUL62368-1			
	Medical	IEC60601-1 Ed 3.1 Including Risk Management, ANSI/AAMI ES60601-1 & CSA C22.2 No.6061-1:08, EN60601-1			
	Household	IEC60335-1			

Input

Characteristic	Minimum	Typical	Maximum	Units	Notes & Conditions
Input Voltage - Operating	80	115/230	264	VAC	Derate output from 100% at 90 VAC to 90% at 85 VAC and 80% at 80 VAC
Input Frequency	47	50/60	63	Hz	Agency approval, 47-63 Hz
Power Factor					EN61000-3-2 class A
Input Current - Full Load		0.8/0.4		A	115/230 VAC
Inrush Current			60	A	264 VAC cold start, 25 °C
Earth Leakage Current			270	µA	264 VAC/60 Hz
No load Input Power			0.3	W	
Input Protection	T3.15 A/250 A, 250 V Internal fuse fitted in line and neutral.				

Output - Main Output

Characteristic	Minimum	Typical	Maximum	Units	Notes & Conditions
Output Voltage	12		48	VDC	See Models and Ratings table
Initial Set Accuracy			±1	%	50% load, 115/230 VAC
Output Voltage Adjustment	±10			%	
Minimum Load	0			A	No minimum load required
Start Up Delay		1	2	s	
Output Rise Time			50	ms	
Hold Up Time	8.3/20			ms	Min at full load 115/230 VAC
Line Regulation			±0.5	%	90-264 VAC
Load Regulation			1	%	0-100% load.
Transient Response			4	%	Recovery within 1% in less than 500 µs for a 50-75% and 75-50% load step
Over/Undershoot			5	%	Full load
Ripple & Noise			1	% pk-pk	20 MHz bandwidth
Overvoltage Protection	115		140	%Vnom	Continuous trip and restart (hiccup)
Overload Protection	110		180	% I nom	
Short Circuit Protection					Continuous trip and restart (hiccup)
Temperature Coefficient			0.05	%/°C	

General

Characteristic	Minimum	Typical	Maximum	Units	Notes & Conditions
Efficiency		84		%	115/230 VAC, 100% load
Isolation: Input to Output Input to Ground Output to Ground	4000			VAC	2 MOPP
	1500			VAC	1 MOPP
	500			VAC	1 MOPP at output voltage
Power Density			6.4	W/in ³	
Mean Time Between Failure	500			kHrs	MIL-HDBK-217F, Notice 2 +25 °C GB
Weight		0.19 (86.0)		lb(g)	

Environmental

Characteristic	Minimum	Typical	Maximum	Units	Notes & Conditions
Operating Temperature	-25		+70	°C	See derating curve, fig.1
Storage Temperature	-40		+85	°C	
Humidity	5		95	%RH	Non-condensing
Operating Altitude			5000/4000	m	ITE/Medical
Shock	±3 x 30g shocks in each plane, total 18 shocks. 30g = 11ms (+/- 0.5msecs), half sine. Conforms to EN60068-2-27				
Vibration	Single axis 10-500 Hz at 2g sweep and endurance at resonance in all 3 planes. Conforms to EN60068-2-6				

Temperature Derating Curve

Figure 1

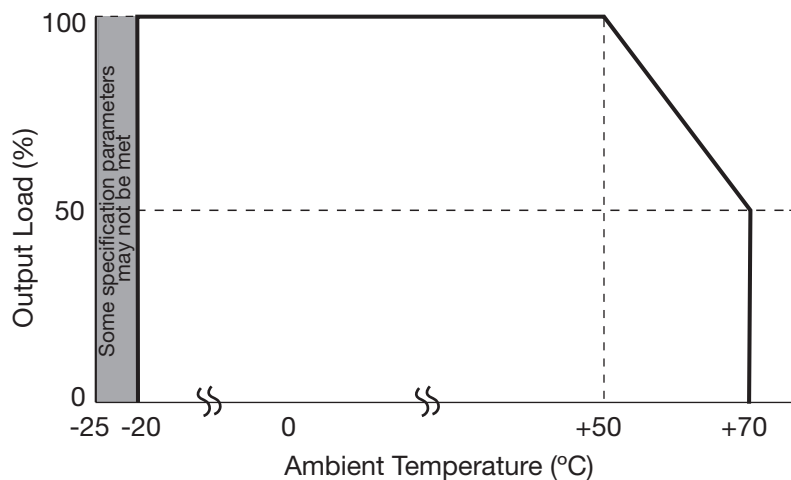

Notes

FCS40US12 ripple and noise is <1.5% from -25 °C to 0 °C reducing to <1% after 1 minute warm up.

EMC: Emissions

Phenomenon	Standard	Test Level	Notes & Conditions
Conducted	EN55011/32	Class B	See note 1.
Radiated	EN55011/32	Class A	Class B with Würth Electronics 742 700 91 with 4 turns on AC Input. See note 1.
Harmonic Current	EN61000-3-2	Class A	
Voltage Fluctuations	EN61000-3-3		

Notes

1. For class I applications, ensure the two mounting holes marked with are connected together and to safety earth to meet conducted and radiated emissions.

EMC: Immunity

Phenomenon	Standard	Test Level	Criteria	Notes & Conditions
Medical Device EMC	IEC60601-1-2	Ed.4.0 : 2014	as below	
Low Voltage PSU EMC	EN61204-3	High severity level	as below	
ESD	EN61000-4-2	±8kV contact, ±15kV air	A	
Radiated	EN61000-4-3	3	A	
EFT	EN61000-4-4	3	A	
Surge	EN61000-4-5	Installation class 3	A	
Conducted	EN61000-4-6	3	A	
Magnetic Fields	EN61000-4-8	4	A	
Dips and Interruptions	EN61000-4-11 (100 VAC)	Dip 100% (0 VAC), 8.4 ms	A	25% derating
		Dip 100% (0 VAC), 16.7 ms	B	
		Dip 60% (40 VAC), 200 ms	B	
		Dip 30% (70 VAC), 500 ms	B	
		Dip 20% (80 VAC), 5000 ms	B	
		Int 100% (0 VAC), 5000 ms	B	
	EN61000-4-11 (115 VAC)	Dip 100% (0 VAC), 8.4 ms	A	
		Dip 100% (0 VAC), 16.7 ms	B	
		Dip 60% (40 VAC), 200 ms	B	
		Dip 30% (70 VAC), 500 ms	B	
		Dip 20% (80 VAC), 5000 ms	B	
		Int 100% (0 VAC), 5000 ms	B	
	EN61000-4-11 (240 VAC)	Dip 100% (0 VAC), 10 ms	A	
		Dip 100% (0 VAC), 20 ms	B	
		Dip 60% (96 VAC), 200 ms	B	
		Dip 30% (168 VAC), 500 ms	B	
		Dip 20% (192 VAC), 5000 ms	B	
		Int 100% (0 VAC), 5000 ms	B	
	EN60601-1-2 (100 VAC)	Dip 100% (0 VAC), 10 ms	A	20% derating
		Dip 100% (0 VAC), 20 ms	A	50% derating
		Dip 60% (40 VAC), 100 ms	A	75% derating
		Dip 30% (70 VAC), 500 ms	A	
		Int 100% (0 VAC), 5000 ms	B	
	EN60601-1-2 (240 VAC)	Dip 100% (0 VAC), 10 ms	A	
Dip 100% (0 VAC), 20 ms		A		
Dip 60% (96 VAC), 100 ms		A		
Dip 30% (168 VAC), 500 ms		A		
Int 100% (0 VAC), 5000 ms		B		

Safety Approvals

Safety Agency	Safety Standard	Notes & Conditions
CB Report	IEC60950-1:2005, IEC62368-1:2014	Information Technology
UL	cUL62368-1	Information Technology
TUV	EN62368-1	Information Technology
CE	LVD	

Safety Agency	Safety Standard	Notes & Conditions
CB Report	IEC60601-1 Ed 3.1 Including Risk Management	Medical
UL	ANSI/AAMI ES60601-1: & CSA C22.2 No.6061-1:08	Medical
CE	EN60601-1	Medical

Safety Agency	Safety Standard	Notes & Conditions
CB Report	IEC60335-1	Household

Isolation	Safety Standard	Notes & Conditions
Primary to Secondary	2 x MOPP (Means of Patient Protection)	IEC60601-1 Ed 3.1
Primary to Earth	1 x MOPP (Means of Patient Protection)	
Secondary to Earth	1 x MOPP (Means of Patient Protection at output voltage)	

Mechanical Details

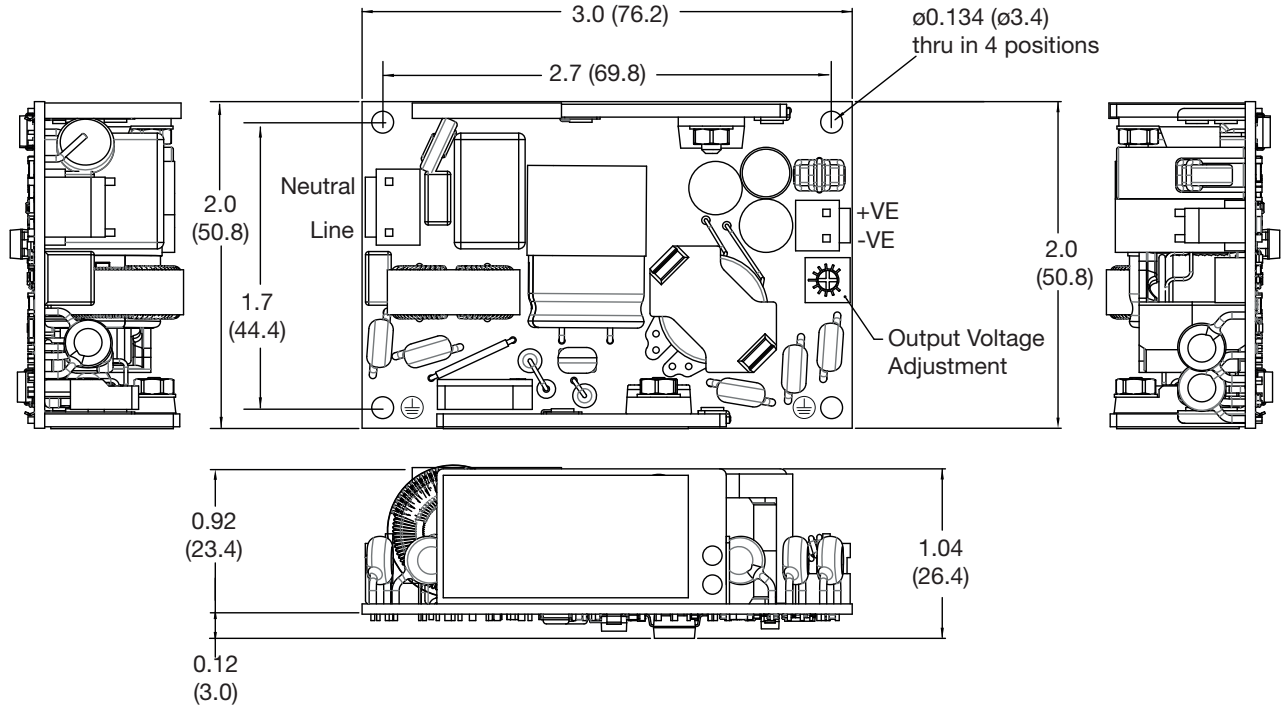

CN1 - Input Connector	
Pin 1	Line
Pin 2	Not Fitted
Pin 3	Neutral

Mates with JST housing VHR-3N and JST Series SVH-21T-P1.1 crimp terminals

CN2 - Output Connector	
Pin 1	+Vout
Pin 2	-Vout

Mates with JST housing VHR-2N and JST Series SVH-21T-P1.1 crimp terminals

Mounting hole marked with \oplus must be connected to safety earth for class I applications

Notes

1. All dimensions shown in inches (mm).
Tolerance: ± 0.02 (0.5)

2. Weight: 0.19 lbs (86 g) approx.

X-ON Electronics

Largest Supplier of Electrical and Electronic Components

Click to view similar products for [Switching Power Supplies](#) category:

Click to view products by [XP Power](#) manufacturer:

Other Similar products are found below :

[70841011](#) [73-551-0005](#) [73-551-0048](#) [PS3E-B12F](#) [PS3E-E12F](#) [AAD600S-4-OP](#) [R22095](#) [KD0204](#) [9021](#) [LDIN100150](#) [LPM000-BBAR-01](#)
[LPX17S-C](#) [EVS57-10R6/R](#) [FP80](#) [FRV7000G](#) [22929](#) [PS3E-F12F](#) [CQM1IA121](#) [40370121900](#) [VI-PU22-EXX](#) [40370121910](#) [LDIN5075](#)
[LPM615-CHAS](#) [LPX140-C](#) [09-160CFG](#) [70841025](#) [VPX3000-CBL-DC](#) [VI-LUL-IU](#) [LPM000-BBAR-05](#) [LPM000-BBAR-08](#) [LPM124-](#)
[OUTA1-48](#) [LPM000-BBAR-07](#) [LPM109-OUTA1-10](#) [LPM616-CHAS](#) [08-30466-1055G](#) [08-30466-2175G](#) [08-30466-2125G](#) [DMB-EWG](#)
[TVQF-1219-18S](#) [6504-226-2101](#) [CQM1IPS01](#) [SP-300-5](#) [CQM1-IPS02](#) [VI-MUL-ES](#) [22829](#) [08-30466-0065G](#) [VI-RU031-EWWX](#) [08-30466-](#)
[0028G](#) [EP3000AC48INZ](#) [VP-C2104853](#)