

10 Watts

- Output Voltages from 200V to 6kV
- Output Voltage Proportional to Input
- Low Turn-on Voltage 0.7VDC
- Input to Output Isolation <2.5kVDC
- Low Profile 0.5"
- Dual Output Option
- Arc & Short Circuit Protected
- Overtemperature & Overvoltage Protection with Auto Shutdown
- No Minimum Load
- 3 Year Warranty



The FS Series is an isolated, proportional DC to high voltage DC converter offering stout design and enhanced features for excellent long-term reliability. A proprietary, quasi-sinewave, resonant oscillator produces clean high voltage with inherently low ripple, low EMI/RFI, low input ripple current, and low conducted emissions. The internal transformer temperature and input voltage are actively monitored with supervisory circuits and fed into a shutdown circuit, preventing excessive input voltage or over-temperature failures.

This series features sturdy, galvanic input-to-output high voltage isolation, conservatively rated at +/-2.5kV + Vout with less than 100pF of coupling capacitance and less than 100nA of leakage current. Robustness and high reliability have been designed into each model by incorporating output arc surge current limiting and short circuit protection.

Dimensions:

FS Series: 1.12 x 2.25 x 0.50" (28.5 x 57.15 x 12.7mm)

Key Applications:

- Mass Spectrometry
- Electrostatic Chucks
- Electrophoresis
- Capacitor Charging
- Particle Counter
- Isolation Testing
- Medical Laser Treatment

Input

Characteristic	Minimum	Typical	Maximum	Units	Notes & Conditions
Input Voltage	0.7		12, 15, 24, 28	VDC	See Models and Ratings Table.
Input Current			1.5	A	See Models and Ratings Table.

Output

Characteristic	Minimum	Typical	Maximum	Units	Notes & Conditions
Output Voltage			6,000	VDC	See Models and Ratings Table
Output Current			50	mA	See Models and Ratings Table
Output Voltage Tolerance		+5, -5		%	At Max Vout, Full Load
Minimum Load	No minimum load required				
Regulation	Unregulated, Output is proportional to Input. See Application Notes.				
Short Circuit Protection	Protected against short circuit conditions indefinitely. B versions not included.				
Ripple and Noise	1		6	%	See Models and Ratings Table.

Notes

1. Maximum rated output current is available at maximum rated output voltage.
2. Output voltage is load dependent. Under light or no-load conditions, reduce the input voltage so maximum rated output voltage is not exceeded.
3. Specifications after 1 hour warm-up, full load, at 25°C unless otherwise indicated.
4. Maximum output power is typically proportional to input voltage from 40% of input voltage to maximum.
5. Short circuit protection not available with -B suffix.
6. Proper thermal management techniques are required to maintain safe case temperature at maximum power output.
7. Ripple specification for center-tapped units applies to the voltage between the positive and negative output terminals.
8. Models FS50 and FS60 do not have the arc protection feature.

Environmental

Characteristic	Minimum	Typical	Maximum	Units	Notes & Conditions
Operating Temperature (case)	-25		+75	°C	Standard operating temperature
Operating Temperature (case)	-55		+85	°C	Extended operating temp, -T models
Storage Temperature	-55		+105	°C	
Humidity			95	%RH	Non-condensing
Cooling					Natural Convection

General

Characteristic	Minimum	Typical	Maximum	Units	Notes & Conditions
Isolation: Input to Output			2,500	V	< ±2,500 VDC Bias on Pin 4.
Leakage Current			100	nA	
Switching Frequency	25		125	kHz	Stable frequency over entire output voltage range.
Construction	Solid vacuum encapsulation, UL 94 V-0 rated. Anodized aluminum heatsink surface, two threaded blind inserts.				
Mean Time Between Failure	840			kHrs	Bellcore TR 332

Block Diagram

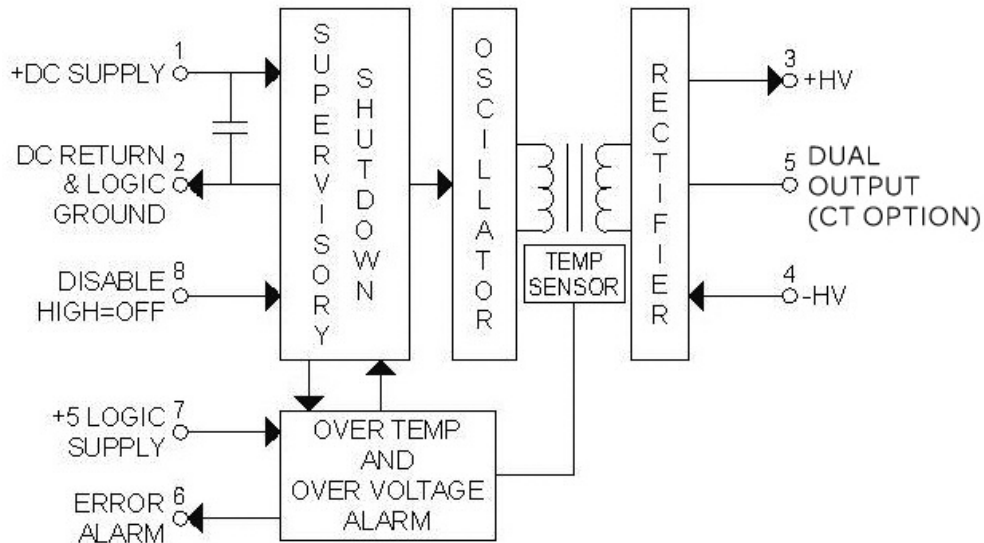

SMART Protection Features

The FS Series power supplies are provided with internal input over-voltage and over-temperature protection. The internal transformer temperature and input voltage are actively monitored with supervisory circuits and fed into a shutdown circuit, preventing excessive input voltage or over-temperature failures. Should preset limits be exceeded, the power supply will be temporarily disabled. A TTL-compatible, latching alarm signal on Pin 6 transitions from low to high to indicate an alarm condition has occurred. Sustained presence of an input over-voltage may damage input components. The user should respond to the alarm by removing the potentially damaging input.

If/when the fault condition is removed, the unit will recover and restore itself to normal operation, ensuring maximum reliability in the field. However, the pin 6 error signal will remain high to indicate an alarm event has occurred. To clear the alarm output, the +5V logic input must be toggled low for >250ms, then returned high.

The fault monitor circuits are powered by the +5V logic input voltage and draw <25mA.

SMART Protection features are not included with B suffix.

Models & Ratings

Output Voltage	Output Current	Ripple	Polarity	Input Voltage	Input Current, No Load	Input Current, Full Load	Model Number
0 to 200V	50mA	<6%	Reversible	12V	<300mA	<1.25A	FS02-12
0 to 200V	50mA	<6%	Reversible	24V	<150mA	<650mA	FS02-24
0 to 200V	50mA	<6%	Reversible	24V	<150mA	<650mA	FS02-24BT
0 to +/-100V	50mA	<6%	Bipolar	12V	<300mA	<1.25A	FS02CT-12
0 to +/-100V	50mA	<6%	Bipolar	15V	<250mA	<1.15A	FS02CT-15
0 to +/-100V	50mA	<6%	Bipolar	24V	<150mA	<650mA	FS02CT-24
0 to 300V	33.3mA	<2%	Reversible	12V	<300mA	<1.25A	FS03-12
0 to 500V	20mA	<2%	Reversible	12V	<300mA	<1.25A	FS05-12
0 to 500V	20mA	<2%	Reversible	15V	<250mA	<1.15A	FS05-15
0 to 500V	20mA	<2%	Reversible	24V	<150mA	<650mA	FS05-24
0 to 500V	20mA	<2%	Reversible	24V	<150mA	<650mA	FS05-24B
0 to 500V	20mA	<2%	Reversible	28V	<125mA	<500mA	FS05-28
0 to 500V	20mA	<2%	Reversible	28V	<125mA	<500mA	FS05-28B
0 to +/-250V	20mA	<2%	Bipolar	12V	<300mA	<1.25A	FS05CT-12
0 to +/-250V	20mA	<2%	Bipolar	24V	<150mA	<650mA	FS05CT-24
0 to 1,000V	10mA	<1%	Reversible	12V	<300mA	<1.25A	FS10-12
0 to 1,000V	10mA	<1%	Reversible	12V	<300mA	<1.25A	FS10-12B
0 to 1,000V	10mA	<1%	Reversible	24V	<150mA	<650mA	FS10-24
0 to +/-500V	10mA	<1%	Bipolar	12V	<300mA	<1.25A	FS10CT-12
0 to +/-500V	10mA	<1%	Bipolar	24V	<150mA	<650mA	FS10CT-24
0 to 2,000V	5mA	<2.5%	Reversible	12V	<300mA	<1.25A	FS20-12
0 to 2,000V	5mA	<2.5%	Reversible	12V	<300mA	<1.25A	FS20-12B
0 to 2,000V	5mA	<2.5%	Reversible	15V	<250mA	<1.15A	FS20-15
0 to +/-1,000V	5mA	<2.5%	Bipolar	12V	<300mA	<1.25A	FS20CT-12T
0 to +/-1,000V	5mA	<2.5%	Bipolar	15V	<250mA	<1.15A	FS20CT-15
0 to +/-1,000V	5mA	<2.5%	Bipolar	24V	<150mA	<650mA	FS20CT-24
0 to +/-1,000V	5mA	<2.5%	Bipolar	28V	<125mA	<500mA	FS20CT-28
0 to 3,000V	3.33mA	<2%	Reversible	12V	<300mA	<1.25A	FS30-12
0 to 3,000V	3.33mA	<2%	Reversible	24V	<150mA	<650mA	FS30-24B
0 to 4,000V	2.5mA	<1.5%	Reversible	12V	<300mA	<1.25A	FS40-12
0 to 4,000V	2.5mA	<1.5%	Reversible	12V	<300mA	<1.25A	FS40-12B
0 to +/-2,000V	2.5mA	<1.5%	Bipolar	12V	<300mA	<1.25A	FS40CT-12
0 to +/-2,000V	2.5mA	<1.5%	Bipolar	12V	<300mA	<1.25A	FS40CT-12T
0 to -5,000V	2mA	<2.5%	Negative	12V	<400mA	<1.5A	FS50N-12
0 to -5,000V	2mA	<2.5%	Negative	24V	<200mA	<750mA	FS50N-24
0 to +5,000V	2mA	<2.5%	Positive	12V	<400mA	<1.5A	FS50P-12
0 to +5,000V	2mA	<2.5%	Positive	24V	<200mA	<750mA	FS50P-24
0 to +5,000V	2mA	<2.5%	Positive	24V	<200mA	<750mA	FS50P-24B
0 to -6,000V	1.67mA	<2.5%	Negative	12V	<400mA	<1.5A	FS60N-12
0 to -6,000V	1.67mA	<2.5%	Negative	12V	<400mA	<1.5A	FS60N-12B
0 to +6,000V	1.67mA	<2.5%	Positive	12V	<400mA	<1.5A	FS60P-12
0 to +6,000V	1.67mA	<2.5%	Positive	12V	<400mA	<1.5A	FS60P-12B
0 to +6,000V	1.67mA	<2.5%	Positive	24V	<200mA	<750mA	FS60P-24
0 to +6,000V	1.67mA	<2.5%	Positive	24V	<200mA	<750mA	FS60P-24B
0 to +6,000V	1.67mA	<2.5%	Positive	24V	<200mA	<750mA	FS60P-24T

Notes

- All orderable part numbers are listed above.
- B Suffix is used for models without SMART protection features described on page 2.
- T Suffix indicates extended operating temperature, see page 2 Environmental.
- CT indicates center tap pin for dual output.

Mechanical Details

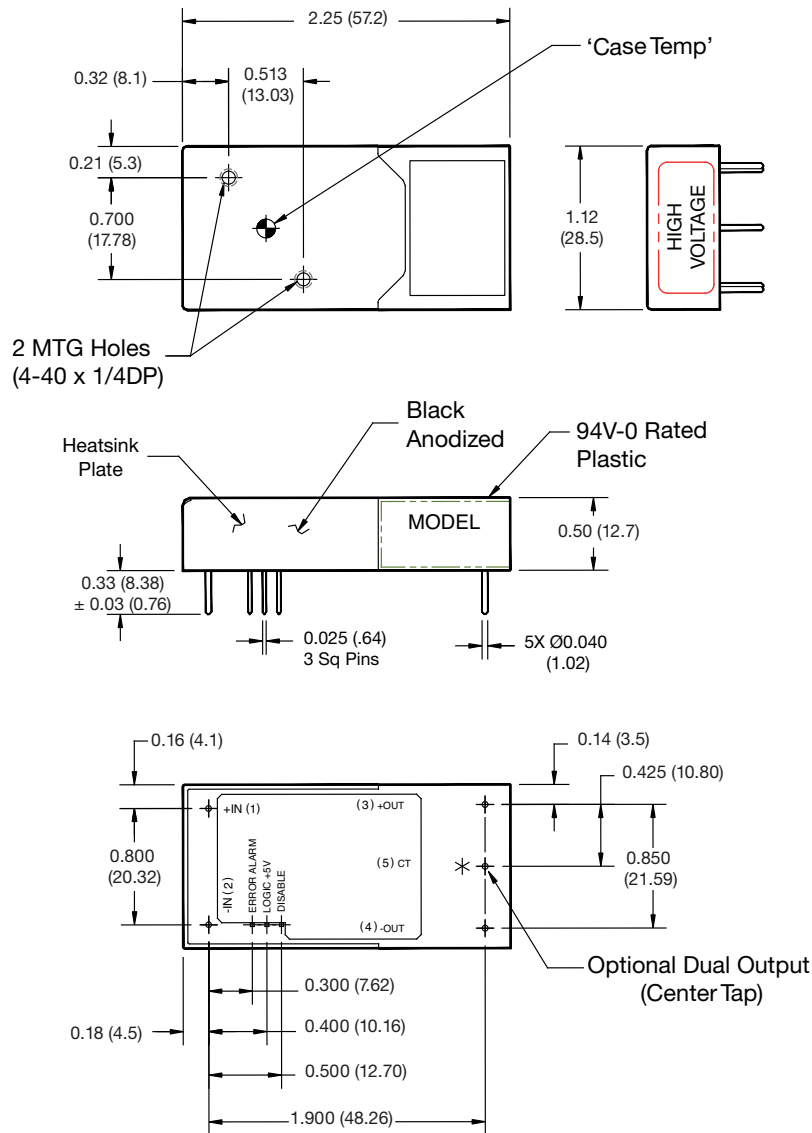

Pin #	Function	
	FS02 - FS40	FS50 & FS60
1	(+) Input	(+) Input
2	(-) Input	(-) Input
3	(+) Output	HV Output
4	(-) Output	HV Return
5	(Center Tap) Optional	N/A
6	Error Alarm (B Version Not Included)	
7	Logic Input: +5V +/-5% (B Version Not Included)	
8	Disable: TTL High = Off (B Version Not Included)	

Notes

- All dimensions are in inches (mm)
- Weight 1.6oz (45g)
- Tolerance: X.XX±0.02 (0.51)
- Pin Tolerance: ±0.005 (0.127)
- FS02 - FS40 are floating. FS50 and FS60 must be ordered as positive or negative.
- Pins 6,7, and 8 are not included with B suffix models.

Application Notes

FS02 - FS40 Positive output for reversible models

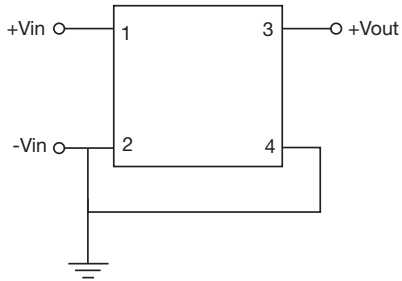

FS02 - FS40 Negative output for reversible models

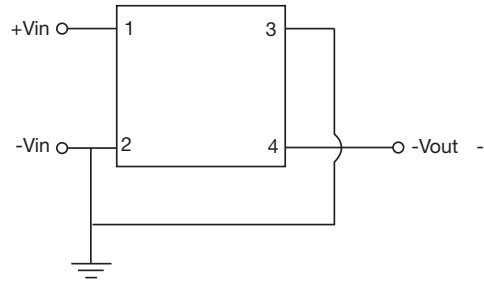

FS02CT - FS40CT Dual output

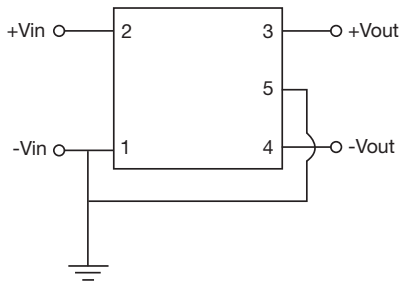

FS50 - FS60 Order as positive or negative output

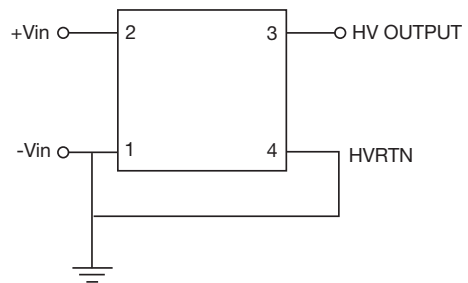

Output Voltage vs. Input Voltage

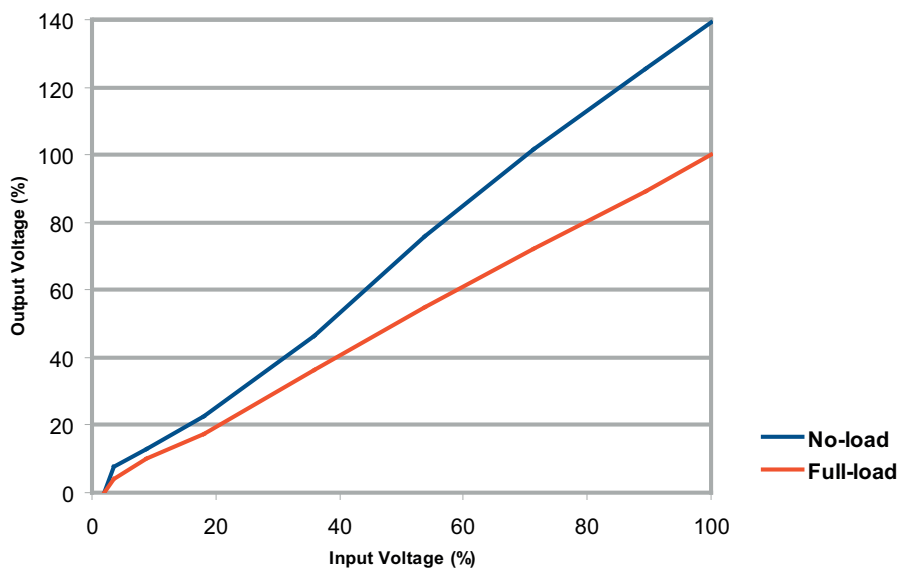

FS - VM Vertical Mount Adapter Board

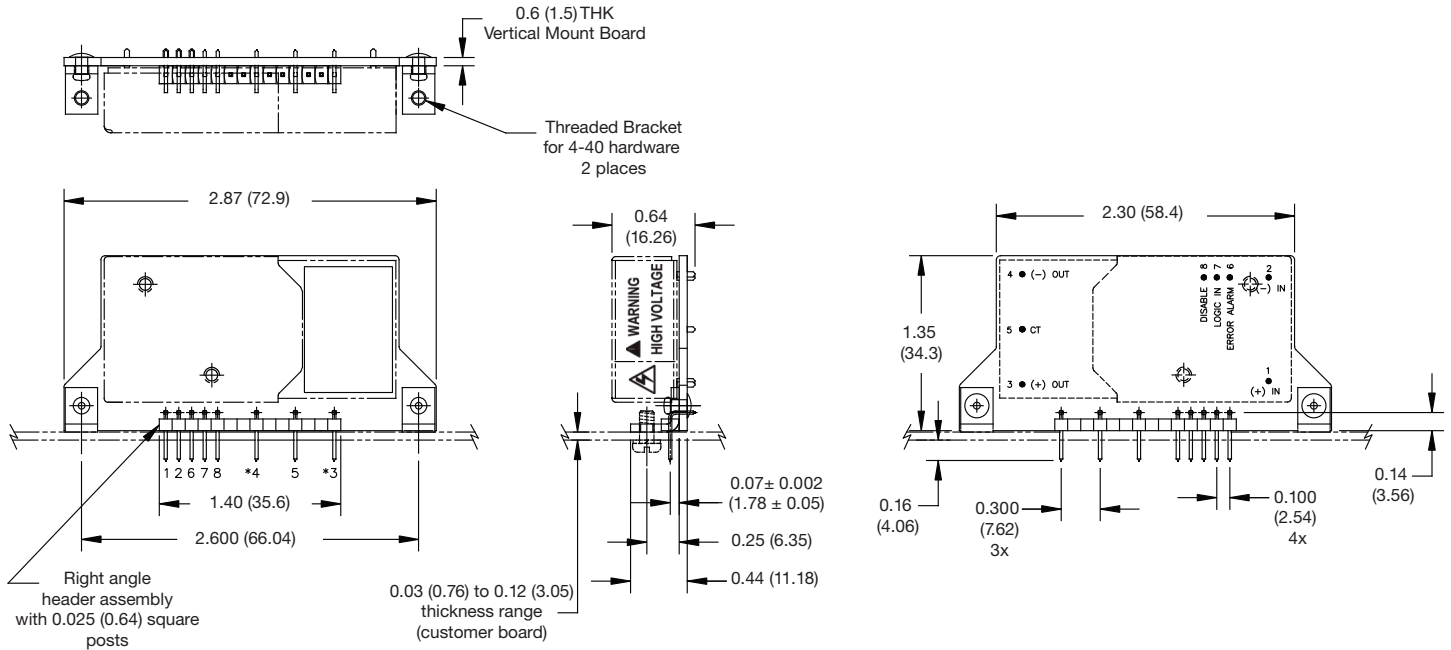

This FS-VM adaptor board provides a convenient way to mount any FS Series high voltage power supply DC to high voltage DC converter on its side, minimizing the X-Y footprint to conserve board real estate. Please note when ordering, the FS Series unit is not included and must be ordered separately.

Weight <1oz (28.3g)
 Tolerance: X.XX±0.02 (0.51)
 Pin Tolerance: ±0.005 (0.127)

FS - EB Evaluation Board

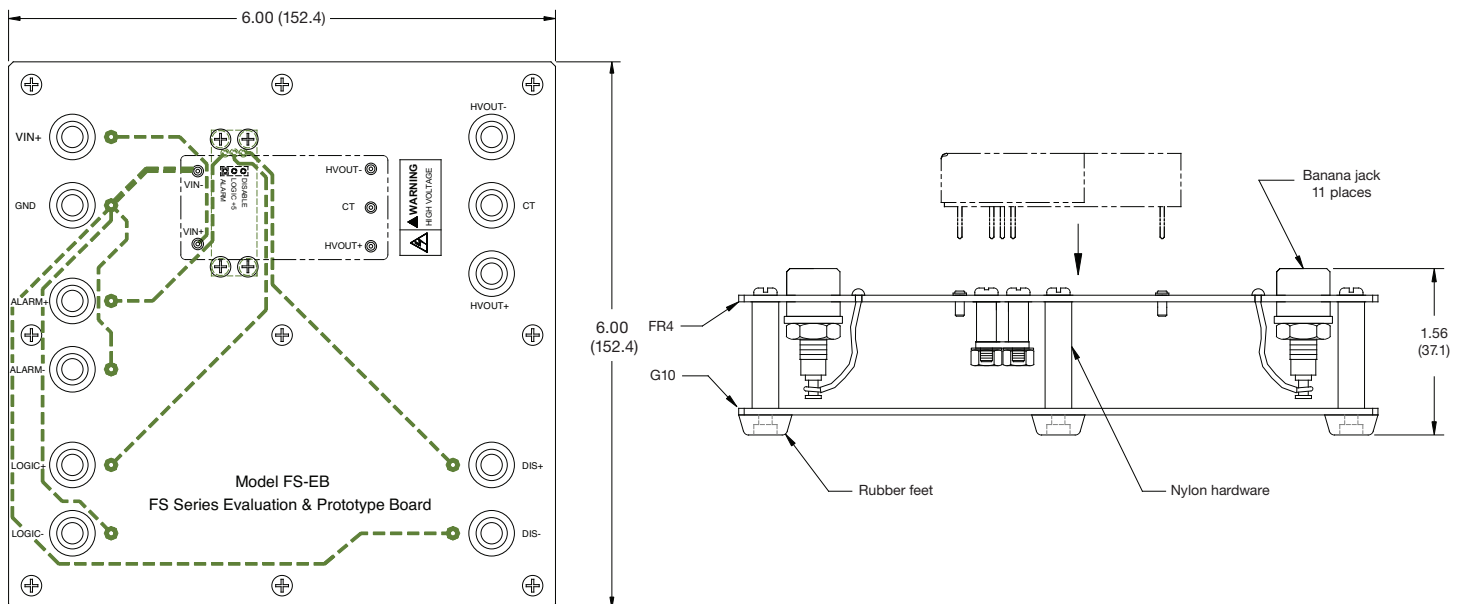

This FS-EB evaluation board provides a convenient package to use any FS Series high voltage power supply without having to fit it onto a PC board. The board provides for easy prototyping and evaluation. Please note when ordering, the FS Series unit is not included and must be ordered separately.

Weight <7oz (200g)
 Tolerance: X.XX±0.02 (0.51)
 Pin Tolerance: ±0.005 (0.127)

X-ON Electronics

Largest Supplier of Electrical and Electronic Components

Click to view similar products for [Power Management IC Development Tools](#) category:

Click to view products by [XP Power](#) manufacturer:

Other Similar products are found below :

[EVAL-ADM1168LQEBZ](#) [EVB-EP5348UI](#) [MIC23451-AAAYFL EV](#) [MIC5281YMME EV](#) [DA9063-EVAL](#) [ADP122-3.3-EVALZ](#) [ADP130-0.8-EVALZ](#) [ADP130-1.2-EVALZ](#) [ADP130-1.5-EVALZ](#) [ADP130-1.8-EVALZ](#) [ADP1714-3.3-EVALZ](#) [ADP1716-2.5-EVALZ](#) [ADP1740-1.5-EVALZ](#) [ADP1752-1.5-EVALZ](#) [ADP1828LC-EVALZ](#) [ADP1870-0.3-EVALZ](#) [ADP1871-0.6-EVALZ](#) [ADP1873-0.6-EVALZ](#) [ADP1874-0.3-EVALZ](#) [ADP1882-1.0-EVALZ](#) [ADP199CB-EVALZ](#) [ADP2102-1.25-EVALZ](#) [ADP2102-1.875EVALZ](#) [ADP2102-1.8-EVALZ](#) [ADP2102-2-EVALZ](#) [ADP2102-3-EVALZ](#) [ADP2102-4-EVALZ](#) [ADP2106-1.8-EVALZ](#) [ADP2147CB-110EVALZ](#) [AS3606-DB](#) [BQ24010EVM](#) [BQ24075TEVM](#) [BQ24155EVM](#) [BQ24157EVM-697](#) [BQ24160EVM-742](#) [BQ24296MEVM-655](#) [BQ25010EVM](#) [BQ3055EVM](#) [NCV891330PD50GEVB](#) [ISLUSBI2CKIT1Z](#) [LM2744EVAL](#) [LM2854EVAL](#) [LM3658SD-AEV/NOPB](#) [LM3658SDEV/NOPB](#) [LM3691TL-1.8EV/NOPB](#) [LM4510SDEV/NOPB](#) [LM5033SD-EVAL](#) [LP38512TS-1.8EV](#) [EVAL-ADM1186-1MBZ](#) [EVAL-ADM1186-2MBZ](#)